

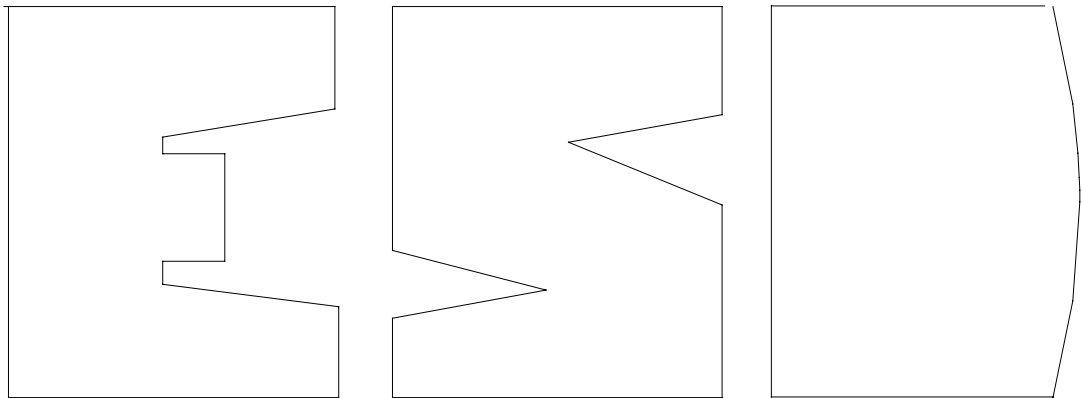

Protocol for Equipment Leak Emission Estimates



1995 Protocol for Equipment Leak Emission Estimates

Emission Standards Division

U.S. ENVIRONMENTAL PROTECTION AGENCY
Office of Air and Radiation
Office of Air Quality Planning and Standards
Research Triangle Park, North Carolina 27711

November 1995

This report has been reviewed by the Emission Standards Division of the Office of Air Quality Planning and Standards, the EPA and approved for publication. Mention of trade names or commercial products is not intended to constitute endorsement or recommendation for use. Copies of this report are available through the Library Services Office (MD-35), U.S. Environmental Protection Agency, Research Triangle Park, North Carolina 27711; from the Office of Air Quality Planning and Standards Technology Transfer Network, U.S. Environmental Protection Agency, Research Triangle Park, North Carolina 27711; or, for a fee, from the National Technical Information Services, 5285 Port Royal Road, Springfield, Virginia 22161.

Publication No. EPA-453/R-95-017

FOREWORD

The EPA's protocol for estimating equipment leak emissions is the result of detailed information gathering and data analysis. The protocol was written to provide a thorough understanding of acceptable approaches to generating process unit-specific emission estimates. In preparing this document, the EPA has encouraged knowledgeable individuals in industry and the regulatory community to provide comments.

The EPA has put forth considerable effort to make this document as comprehensive as possible. However, it should be understood that not all details and topics pertaining to equipment leaks could feasibly be included in this document. Additionally, it should be understood that the procedures presented in this document are not necessarily suitable for all applications. There will be cases where it will be necessary for the user of the document to make a professional judgement as to the appropriate technical approach for collecting and analyzing data used to estimate equipment leak emissions.

Additional data on equipment leak emissions continues to be collected. It is the intent of the EPA to periodically update this document after analysis of the data warrants such an update. For example, data recently collected in the petroleum industry has been used to revise the existing refinery correlations, which are based on data collected in the late 1970s. Furthermore, as new techniques for collecting and analyzing data are developed, they will be included in updated versions of this document.

Mention of any manufacturer or company name within this document does not represent endorsement by the EPA.

TABLE OF CONTENTS

<u>Section</u>	<u>Page</u>
FOREWORD	i
1.0 INTRODUCTION	1-1
2.0 DEVELOPMENT OF EQUIPMENT LEAK EMISSION ESTIMATES	2-1
2.1 Introduction	2-1
2.2 General Information on the Approaches for Estimating Equipment Leak Emissions	2-3
2.2.1 Equipment Leak Emission Estimation Approaches	2-3
2.2.2 Overview of Equipment Leak Data Collection	2-6
2.3 Approaches for Estimating Equipment Leak Emissions	2-10
2.3.1 Average Emission Factor Approach	2-10
2.3.2 Screening Ranges Approach	2-18
2.3.3 EPA Correlation Approach	2-24
2.3.4 Unit-Specific Correlation Approach	2-38
2.4 Special Topics	2-44
2.4.1 Speciating Emissions	2-45
2.4.2 Using Response Factors	2-46
2.4.3 Monitoring Instrument Type and Calibration Gas	2-51
2.4.4 Estimating Emissions for Equipment Not Screened	2-51
2.4.5 Using Screening Data Collected at Several Different Times	2-52
2.4.6 Estimating VOC Emission Rates from Equipment Containing Non-VOC's	2-52
2.4.7 Estimating Equipment Leak Emissions of Inorganic Compounds	2-53
2.5 References	2-54
3.0 SOURCE SCREENING	3-1
3.1 Introduction	3-1
3.2 Monitoring Instruments	3-2
3.2.1 Operating Principles and Limitations of Portable VOC Detection Devices	3-2

TABLE OF CONTENTS (Continued)

<u>Section</u>	<u>Page</u>
3.2.2 Specifications and Performance Criteria of Portable VOC Detection Devices	3-4
3.2.3 Use of Monitoring Devices That Do Not Meet EPA Reference Method 21 Requirements . . .	3-10
3.3 The Screening Program	3-12
3.3.1 Identification of Equipment to be Screened	3-12
3.3.2 Procedure for Screening	3-15
3.3.3 Data Handling	3-25
3.4 References	3-27
4.0 MASS EMISSION SAMPLING	4-1
4.1 Introduction	4-1
4.2 Sampling Methods	4-2
4.2.1 Vacuum Method	4-4
4.2.2 Blow-Through Method	4-8
4.3 Source Enclosure	4-15
4.3.1 Valves	4-15
4.3.2 Pumps and Agitators	4-16
4.3.3 Compressors	4-17
4.3.4 Connectors	4-17
4.3.5 Relief Valves	4-18
4.4 Analytical Techniques	4-18
4.4.1 Analytical Instrumentation	4-19
4.4.2 Calibration of Analytical Instruments . .	4-19
4.4.3 Analytical Techniques for Condensate . . .	4-21
4.4.4 Calibration Procedures for the Portable Monitoring Instrument	4-21
4.5 Quality Control and Quality Assurance Guidelines	4-21
4.5.1 Quality Control Procedures	4-22
4.5.2 Quality Assurance Procedures	4-25
4.6 References	4-29
5.0 ESTIMATION OF CONTROL EFFICIENCIES FOR EQUIPMENT LEAK CONTROL TECHNIQUES	5-1
5.1 Introduction	5-1

TABLE OF CONTENTS (Continued)

<u>Section</u>	<u>Page</u>
5.2 Equipment Modification Control Efficiency	5-1
5.2.1 Closed-Vent Systems	5-2
5.2.2 Pumps	5-2
5.2.3 Compressors	5-4
5.2.4 Pressure Relief Valves	5-4
5.2.5 Valves	5-5
5.2.6 Connectors	5-5
5.2.7 Open-Ended Lines	5-6
5.2.8 Sampling Connections	5-6
5.3 Leak Detection and Repair Control Effectiveness . .	5-6
5.3.1 Approach for Estimating LDAR Control Effectiveness	5-8
5.3.2 Example Application of Approach	5-57
5.4 References	5-61

APPENDICES

A Example Calculations	A-1
B Leak Rate Screening Value Correlation Development and Revision of SOCFI Correlations and Emission Factors . .	B-1
C Revision of Petroleum Industry Correlations and Emission Factor	C-1
D Response Factors	D-1
E Selection of Sample Size for Screening Connectors . . .	E-1
F Reference Method 21	F-1
G Development of Leak Rate Versus Fraction Leaking Equations and Determination of LDAR Control Effectiveness	G-1

LIST OF TABLES

<u>Table</u>		<u>Page</u>
2-1	SOCMI Average Emission Factors	2-12
2-2	Refinery Average Emission Factors	2-13
2-3	Marketing Terminal Average Emission Factors	2-14
2-4	Oil and Gas Production Operations Average Emission Factors	2-15
2-5	SOCMI Screening Ranges Emission Factors	2-19
2-6	Refinery Screening Ranges Emission Factors	2-20
2-7	Marketing Terminal Screening Ranges Emission Factors	2-21
2-8	Oil and Gas Production Operations Screening Ranges Emission Factors	2-22
2-9	SOCMI Leak Rate/Screening Value Correlations	2-26
2-10	Petroleum Industry Leak Rate/Screening Value Correlations	2-27
2-11	Default-Zero Values: SOCMI Process Units	2-33
2-12	Default-Zero Values: Petroleum Industry	2-34
2-13	10,000 and 100,000 ppmv Screening Value Pegged Emission Rates For SOCMI Process Units	2-36
2-14	10,000 and 100,000 ppmv Screening Value Pegged Emission Rates For the Petroleum Industry	2-37
3-1	Performance Criteria for Portable VOC Detectors	3-6
3-2	Portable VOC Detection Instruments	3-11
3-3	Equipment Leak Emission Sources	3-13
3-4	Example Field Sheets For Equipment Screening Data	3-26
4-1	Calculation Procedures For Leak Rate When Using the Vacuum Method	4-9
4-2	Calculation Procedures For Leak Rate When Using the Blow-Through Method	4-13
4-3	Example GC Calibration Data Sheet	4-20

LIST OF TABLES (Continued)

<u>Table</u>		<u>Page</u>
4-4	Example Data Collection Form For Fugitive Emissions Bagging Test (Blow-Through Method) . . .	4-23
4-5	Example Data Collection Form For Fugitive Emissions Bagging Test (Vacuum Method)	4-24
4-6	Example Drift Test Report Form	4-28
5-1	Summary of Equipment Modifications	5-3
5-2	Control Effectiveness For an LDAR Program At a SOCOMI Process Unit	5-9
5-3	Control Effectiveness For an LDAR Program At a Refinery Process Unit	5-10
5-4	Equations Relating Average Leak Rate to Fraction Leaking at SOCOMI Units	5-46
5-5	Equations Relating Average Leak Rate to Fraction Leaking at Refinery Units	5-47
5-6	Equations Relating Average Leak Rate to Fraction Leaking At Marketing Terminal Units	5-48
5-7	Equations Relating Average Leak Rate to Fraction Leaking At Oil and Gas Production Operating Units	5-50
5-8	Values Used in Example Calculation	5-58
5-9	Example Calculation To Determine the Final Leak Frequency Of SOCOMI Gas Valves In a Monthly Monitoring LDAR Program With a Leak Definition of 10,000 ppmv	5-60

LIST OF FIGURES

<u>Figure</u>		<u>Page</u>
2-1	Overview of Data Collection and Analysis Approaches for Developing Equipment Leak Emissions Inventory	2-4
2-2	SOCMI Correlations Relating Total Organic Compound (TOC) Leak Rate to Screening Value: 0 - 1,000 ppmv	2-28
2-3	SOCMI Correlations Relating Total Organic Compound (TOC) Leak Rate to Screening Value: 1,000 - 1,000,000 ppmv	2-29
2-4	Petroleum Industry Correlations Relating Total Organic Compound (TOC) Leak Rate to Screening Value: 1,000 - 1,000,000 ppmv	2-30
2-5	Petroleum Industry Correlations Relating Total Organic Compound (TOC) Leak Rate to Screening Value: 1,000 - 1,000,000 ppmv	2-31
3-1	Gate Valves	3-17
3-2	Globe Valves	3-18
3-3	Lubricated Plug Valve	3-19
3-4	Ball Valve and Butterfly Valve	3-20
3-5	Weir-Type Diaphragm Valve and Check Valves	3-21
3-6	Centrifugal Pumps	3-23
3-7	Spring-Loaded Relief Valve	3-24
4-1	Sampling Train for Bagging a Source Using the Vacuum Method	4-5
4-2	Equipment Required for the Blow-Through Sampling Technique	4-10
5-1	SOCMI Gas Valve Average Leak Rate Versus Fraction Leaking at Several Leak Definitions	5-11
5-2	SOCMI Light Liquid Valve Average Leak Rate Versus Fraction Leaking at Several Leak Definitions	5-12
5-3	SOCMI Light Liquid Pump Average Leak Rate Versus Fraction Leaking at Several Leak Definitions	5-13

LIST OF FIGURES (Continued)

<u>Figure</u>		<u>Page</u>
5-4	SOCMI Connector Average Leak Rate Versus Fraction Leaking at Several Leak Definitions	5-14
5-5	Refinery Gas Valve Average Leak Rate Versus Fraction Leaking at Several Leak Definitions	5-15
5-6	Refinery Light Liquid Valve Average Leak Rate Versus Fraction Leaking at Several Leak Definitions	5-16
5-7	Refinery Light Liquid Pump Average Leak Rate Versus Fraction Leaking at Several Leak Definitions	5-17
5-8	Refinery Connector Average Leak Rate Versus Fraction Leaking at Several Leak Definitions	5-18
5-9	Marketing Terminal Gas Fittings Average Leak Rate Versus Fraction Leaking at Several Leak Definitions	5-19
5-10	Marketing Terminal Light Liquid Fittings Average Leak Rate Versus Fraction Leaking at Several Leak Definitions	5-20
5-11	Marketing Terminal Gas Others Average Leak Rate Versus Fraction Leaking at Several Leak Definitions	5-21
5-12	Marketing Terminal Light Liquid Others Average Leak Rate Versus Fraction Leaking at Several Leak Definitions	5-22
5-13	Marketing Terminal Light Liquid Pumps Average Leak Rate Versus Fraction Leaking at Several Leak Definitions	5-23
5-14	Marketing Terminal Gas Valves Average Leak Rate Versus Fraction Leaking at Several Leak Definitions	5-24
5-15	Marketing Terminal Light Liquid Valves Average Leak Rate Versus Fraction Leaking at Several Leak Definitions	5-25
5-16	Oil and Gas Production Gas Connectors Average Leak Rate Versus Fraction Leaking at Several Leak Definitions	5-27

LIST OF FIGURES (Continued)

<u>Figure</u>		<u>Page</u>
5-17	Oil and Gas Production Light Oil Connectors Average Leak Rate Versus Fraction Leaking at Several Leak Definitions	5-28
5-18	Oil and Gas Production Water/Oil Connectors Average Leak Rate Versus Fraction Leaking at Several Leak Definitions	5-29
5-19	Oil and Gas Production Gas Flanges Average Leak Rate Versus Fraction Leaking at Several Leak Definitions	5-30
5-20	Oil and Gas Production Light Oil Flanges Average Leak Rate Versus Fraction Leaking at Several Leak Definitions	5-31
5-21	Oil and Gas Production Gas Open-Ended Lines Average Leak Rate Versus Fraction Leaking at Several Leak Definitions	5-32
5-22	Oil and Gas Production Heavy Oil Open-Ended Lines Average Leak Rate Versus Fraction Leaking at Several Leak Definitions	5-33
5-23	Oil and Gas Production Light Oil Open-Ended Lines Average Leak Rate Versus Fraction Leaking at Several Leak Definitions	5-34
5-24	Oil and Gas Production Water/Oil Open-Ended Lines Average Leak Rate Versus Fraction Leaking at Several Leak Definitions	5-35
5-25	Oil and Gas Production Gas Other Average Leak Rate Versus Fraction Leaking at Several Leak Definitions	5-36
5-26	Oil and Gas Production Heavy Oil Other Average Leak Rate Versus Fraction Leaking at Several Leak Definitions	5-37
5-27	Oil and Gas Production Light Oil Other Average Leak Rate Versus Fraction Leaking at Several Leak Definitions	5-38
5-28	Oil and Gas Production Water/Oil Other Average Leak Rate Versus Fraction Leaking at Several Leak Definitions	5-39

LIST OF FIGURES (Continued)

<u>Figure</u>		<u>Page</u>
5-29	Oil and Gas Production Gas Pumps Average Leak Rate Versus Fraction Leaking at Several Leak Definitions	5-40
5-30	Oil and Gas Production Light Oil Pumps Average Leak Rate Versus Fraction Leaking at Several Leak Definitions	5-41
5-31	Oil and Gas Production Gas Valves Average Leak Rate Versus Fraction Leaking at Several Leak Definitions	5-42
5-32	Oil and Gas Production Heavy Oil Valves Average Leak Rate Versus Fraction Leaking at Several Leak Definitions	5-43
5-33	Oil and Gas Production Light Oil Valves Average Leak Rate Versus Fraction Leaking at Several Leak Definitions	5-44
5-34	Oil and Gas Production Water/Oil Valves Average Leak Rate Versus Fraction Leaking at Several Leak Definitions	5-45
5-35	Marketing Terminals Light Liquid Pumps Average Leak Rate Versus Fraction Leaking at Several Leak Definitions	5-55

1.0 INTRODUCTION

This document is an update to the EPA equipment leaks protocol document ("Protocol for Equipment Leak Emission Estimates," EPA-453/R-93-026, June 1993). The purpose of this document is the same as the original protocol document and subsequent revisions- to present standard procedures for estimating mass emissions from equipment leaks. However, this document publishes the results of additional data collection and analysis that has occurred since the original protocol and subsequent revisions were published, and also expands on some of the topics that were covered in the original protocol.

Some of the new features of the updated protocol are:

- (1) New correlation equations, default zero emission rates, and pegged emission rates for the petroleum industry that replace the refinery correlations previously published are presented. The correlations relate screening values obtained using a portable monitoring instrument to mass emissions.
- (2) The document has been expanded to include emission factors for marketing terminals and for oil and gas production operations. The refinery emission factors were not revised due to an unavailability of new data.
- (3) Pegged emission rates for pegged readings at 10,000 ppmv have been added for SOCFI process units.
- (4) Several of the equations in this version of the protocol have been revised by simplifying the symbols to more clearly communicate the concept being conveyed.
- (5) An adjustment has been added to the blow-through method of calculating mass emissions. This adjustment more accurately accounts for the total flow through the bag.

As with the original protocol document, this document presents standard procedures for general use in generating unit-specific emission estimates for permitting and inventories. The document describes methodologies the EPA considers appropriate for development of equipment leak emission estimates. These methodologies are intended to assist States and industry in their efforts to estimate equipment leak emissions.

The updated protocol is divided into five chapters and several appendices. Chapter 2.0 describes how to estimate equipment leak emissions. Chapter 3.0 describes collecting screening data that can be used in the emission estimates. Chapter 4.0 describes collecting unit-specific equipment leak mass emissions data. Chapter 5.0 describes how to estimate the control efficiencies of equipment leak control techniques. The appendices support information contained in the chapters. Each of these chapters and the appendices are briefly described below.

Chapter 2.0 presents the four approaches for estimating total organic emissions from equipment leaks. These approaches are:

- Average Emission Factor Approach;
- Screening Ranges Approach;
- EPA Correlation Approach; and
- Unit-Specific Correlation Approach.

Additionally, several topics that are relevant to estimating equipment leak emissions are addressed. These topics include speciating equipment leak emissions of individual compounds from an equipment piece containing a mixture, using response factors, estimating emissions of volatile organic compounds, estimating emissions of inorganic compounds, and other topics not specifically related to any one of the four approaches.

Chapter 3.0 explains how to perform a screening survey at a process unit. Requirements for the use of a portable monitoring instrument are described. These requirements are based on the EPA Reference Method 21. Additionally, in chapter 3.0, guidance is provided on how to set up a screening program and how to screen different types of equipment.

Chapter 4.0, explains how to collect equipment leak rate data (bagging data) by enclosing individual equipment in a "bag" and measuring mass emissions. These data can be used to develop unit-specific leak rate/screening value correlations. Chapter 4.0 details the rigorous steps that need to be followed when collecting the bagging data to generate unit-specific correlations. These steps are intended to ensure that the data are of high quality.

Chapter 5.0, explains how to estimate the control efficiency of equipment leak emission control techniques. The two primary control techniques for reducing equipment leak emissions are (1) equipment modifications (such as replacing a standard valve with a sealless type) and (2) implementing a leak detection and repair (LDAR) program. Control efficiencies for different equipment leak modifications are summarized, and an approach for estimating the control efficiency of any LDAR program is provided.

Appendices A through G provide additional information supporting the material in the chapters. Appendix A contains detailed example calculations using the approaches described in chapter 2.0. Appendix B documents how the SOCFI correlations and emission factors were revised. Appendix B also serves as a demonstration of how data can be analyzed to develop unit-specific correlations. Appendix C presents the rationale for the development of the petroleum industry correlations, as well as the background for the development of marketing terminal and oil and gas production operations emission factors. Appendix D summarizes available data on response factors. Appendix E provides guidance on how to collect representative screening data for connectors. Appendix F contains a copy of the EPA Reference Method 21. Finally, appendix G demonstrates how LDAR control efficiencies presented in chapter 5.0 were calculated.

2.0. DEVELOPMENT OF EQUIPMENT LEAK EMISSION ESTIMATES

2.1 INTRODUCTION

The purpose of this chapter is to describe the methods for estimating mass emissions from equipment leaks in a chemical processing unit. Four approaches for estimating equipment leak emissions are presented:

Approach 1: Average Emission Factor Approach;

Approach 2: Screening Ranges Approach;

Approach 3: EPA Correlation Approach; and

Approach 4: Unit-Specific Correlation Approach.

General information on these approaches is presented in section 2.2, and detailed information on applying each of the approaches is presented in section 2.3. Included in section 2.3 are emission factors and leak rate/screening value correlations for use in estimating emissions from equipment leaks in the petroleum industry and the synthetic organic chemical manufacturing industry (SOCMI). The SOCMI emission factors and correlations were revised and introduced in the 1993 update of this document. The refinery correlations that have been revised and expanded to include the entire petroleum industry are introduced in this document. Additionally, emission factors for marketing terminals are introduced in this document. Emission factors for gas plants that have been updated and expanded to include oil and gas production operations are also introduced in this document. The procedures in this document estimate emissions of total organic compounds (TOC's). However, special procedures are also described for the purpose of estimating volatile organic compounds (VOC's). As defined by the EPA, VOC's

include all organic compounds except those specifically excluded by the EPA due to negligible photochemical activity.

After the four approaches have been discussed, topics that are not specifically related to any particular approach, but are relevant to how equipment leak emissions are estimated, are addressed in section 2.4. These topics include:

- Estimating emissions of individual compounds within a mixture;
- Using response factors when estimating emissions;
- Considerations regarding the monitoring instrument used;
- Estimating emissions of equipment not screened when other equipment have been screened;
- Using screening data collected at different times;
- Estimating VOC emissions from equipment containing organic compounds excluded from the EPA's classification of TOC's; and
- Estimating emissions from equipment containing inorganic compounds.

Appendices A through E contain supporting documentation for the material presented in this chapter. Appendix A contains detailed example calculations that demonstrate the four approaches for estimating equipment leak emissions, as well as the topics discussed in section 2.4. Appendix B presents details on how unit-specific correlations can be developed, and also presents background information on the revision of the SOCOMI correlations and emission factors. Appendix C presents background information on the development of average emission factors and correlation equations for the petroleum industry. Appendix D offers a detailed listing of available response factors. Appendix E contains information on the minimum number of connectors in a process unit that must be screened in order to obtain a representative sample.

2.2 GENERAL INFORMATION ON THE APPROACHES FOR ESTIMATING EQUIPMENT LEAK EMISSIONS

This section presents general information on the four approaches for estimating equipment leak emissions. Each approach is briefly described, and data requirements for each are summarized. Additionally, background information is presented to provide an historical overview of data collection and analysis on emissions of VOC's from equipment leaks.

2.2.1 Equipment Leak Emission Estimation Approaches

The four approaches described here can be used by any chemical-handling facility to develop an inventory of TOC or VOC emissions from equipment leaks. The approaches, in order of increasing refinement, are: Average Emission Factor Approach, Screening Ranges Approach, EPA Correlation Approach, and Unit-Specific Correlation Approach.

In general, the more refined approaches require more data and provide more accurate emission estimates for a process unit. In the Average Emission Factor Approach and the Screening Ranges Approach, emission factors are combined with equipment counts to estimate emissions. To estimate emissions with the EPA Correlation Approach, measured concentrations (screening values) for all equipment are individually entered into general correlations developed by the EPA. In the Unit-Specific Correlation Approach, screening and leak rate data are measured for a select set of individual equipment components and then used to develop unit-specific correlations. Screening values for all components are then entered into these unit-specific correlations to estimate emissions.

Figure 2-1 is an overview of the data collection and analysis required to apply each of the approaches. As can be seen from this figure, all of the approaches require an accurate count of equipment components by type of equipment (i.e., valves, pumps, connectors, etc.). Additionally, for some of the equipment types, the count must be further described by service (i.e., heavy liquid, light liquid, and gas).

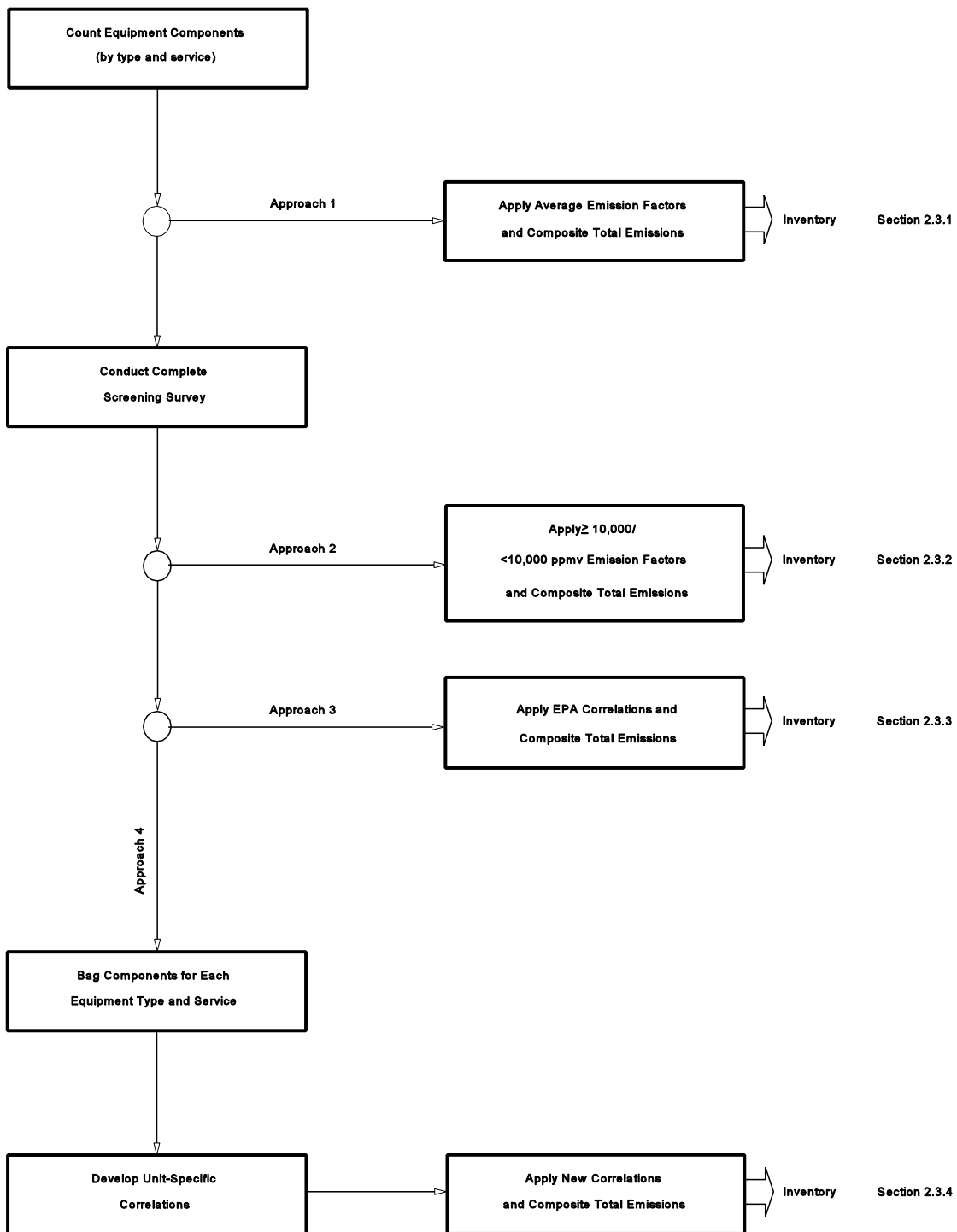

Figure 2-1. Overview of Data Collection and Analysis Approaches for Developing Equipment Leak Emissions Inventory

Except for the Average Emission Factor Approach, all of the approaches require screening data. Screening data are collected by using a portable monitoring instrument to sample air from potential leak interfaces on individual pieces of equipment. A screening value is a measure of the concentration of leaking compounds in the ambient air that provides an indication of the leak rate from an equipment piece, and is measured in units of parts per million by volume (ppmv). The procedures for collecting screening data are presented in chapter 3.0.

In addition to equipment counts and screening data, the Unit-Specific Correlation Approach requires bagging data. Bagging data consist of screening values and their associated measured leak rates. A leak rate is measured by enclosing an equipment piece in a bag to determine the actual mass emission rate of the leak. The screening values and measured leak rates from several pieces of equipment are used to develop a unit-specific correlation. The resulting leak rate/screening value correlation predicts the mass emission rate as a function of the screening value. Procedures for collecting bagging data are described in detail in chapter 4.0.

Each of the approaches are applicable to any chemical-handling facility. However, the EPA has developed more than one set of emission factors and correlations, and the type of process unit being considered governs which set must be used to estimate emissions. Historical data collection on emissions from equipment leaks in SOCFI, refineries, marketing terminals and oils and gas production operations have yielded emission factors and correlations for these source categories. Emission factors and correlations for other source categories have not been developed.

For process units in source categories for which emission factors and/or correlations have not been developed, the factors and/or correlations already developed can be utilized. However, appropriate evidence should indicate that the existing emission factors and correlations are applicable to the source category in question. Criteria for determining the appropriateness of

applying existing emission factors and correlations to another source category may include one or more of the following:

(1) process design, (2) process operation parameters (i.e., pressure and temperature), (3) types of equipment used, and (4) types of material handled. For example, in most cases, SOCFI emission factors and correlations are applicable for estimating equipment leak emissions from the polymer and resin manufacturing industry. This is because, in general, these two industries have comparable process design and comparable process operation, they use the same types of equipment, and they tend to use similar feedstock.

2.2.2 Overview of Equipment Leak Data Collection

Data on equipment leak emissions of organic compounds have been collected from refineries, marketing terminals, oil and gas production operations, and SOCFI process units. Emission factors and correlations have been developed for the following equipment types: valves, pumps, compressors, pressure relief valves, connectors, flanges, and open-ended lines. An "others" category has also been developed for the petroleum industry. For sampling connections, an average emission factor has been developed that estimates the typical amount of material purged when a sample is collected. A brief history of the development of these factors and correlations is presented below.

2.2.2.1 Refinery Assessment Study.^{1,2} In the late 1970s, the EPA initiated the Petroleum Refinery Assessment Study, and equipment leak data from 13 refineries were collected. In this study, equipment was screened and the majority of sources that had screening values over 200 ppmv were bagged. Bagged equipment emission rates were reported as non-methane organic compound emission rates. Average emission factors and correlations for each equipment type were developed based on the screening and bagging data collected in this study.

The Refinery Assessment Study included an investigation of possible correlations between equipment leaks and process variables. The only process variables found to correlate with mass emission rates in a statistically significant manner were

(1) the phase of the process stream (service), and (2) the relative volatility of liquid streams. This finding led to the separation of data for valves, pumps, and pressure relief valves by type of service. Three service categories were defined:

- Gas/vapor - material in a gaseous state at operating conditions;
- Light liquid - material in a liquid state in which the sum of the concentration of individual constituents with a vapor pressure over 0.3 kilopascals (kPa) at 20 °C is greater than or equal to 20 weight percent; and
- Heavy liquid - not in gas/vapor service or light liquid service.

2.2.2.2 Gas Plant Studies.³ A total of six gas plants were screened in two studies: Four were screened by the EPA and two by the American Petroleum Institute. Average emission factors were developed, and information on the percentage of equipment with screening values equal to or greater than 10,000 ppmv was presented. The average factors include emissions of ethane and methane, which are hydrocarbons but are not classified as VOC's.

2.2.2.3 Revised Petroleum Industry Correlations and Emission Factors. During the early-1990's, new petroleum industry equipment leak bagging data were collected and analyzed. The Western States Petroleum Association (WSPA) and the American Petroleum Institute (API) jointly commissioned the 1994 refinery equipment leak report⁴ to evaluate fugitive emissions collected from five petroleum refineries. The API also commissioned the 1993 marketing terminal equipment leak report,⁵ which included bagging data from three marketing terminals, and, along with the Gas Research Institute (GRI), jointly commissioned the 1993 and 1995 oil and gas production operations reports, which included bagging data from 24 facilities.^{6,7} In addition to the bagging data, screening data were also collected from 17 marketing terminals⁸ and 24 oil and gas production facilities.^{6,7} Data from gas/vapor, light liquid, and/or heavy liquid streams were collected for these studies from non-flanged connectors, flanges, open-ended lines, pumps, valves, instruments, loading arms,

pressure relief valves, stuffing boxes, vents, compressors, dump lever arms, diaphragms, drains, hatches, meters, and polished rods.

A specific goal of the above studies was to collect high quality data to enhance or replace the previously published refinery correlations. As a result of the analyses discussed in appendix C, the bagging data collected from refineries, marketing terminals, and oil and gas production facilities during the early-1990's were combined to replace the previously published refinery correlations with correlations applicable to the entire petroleum industry. In addition, the new correlations apply across all services for a given equipment type. The previously published refinery correlations were specific to service and equipment.

The screening data were used to develop average emission factors for marketing terminals and for oil and gas production operations. The average emission factors for oil and gas production operations replace the gas plant factors published in previous versions of this document and apply to light crude, heavy crude, gas plant, gas production and off shore facilities. No new screening data were available for refineries, therefore the previously published refinery average emission factors remain unchanged in this version of the protocol. Appendix C contains more detailed information on how the new petroleum industry correlations, marketing terminal emission factors, and oil and gas production operations emission factors were developed.

2.2.2.4 Original SOCFI Average Emission Factors and Correlations. In 1980, two studies were coordinated by the EPA to collect data from SOCFI process units. These studies were the 24-Unit Study,⁹ and the Six-Unit Maintenance Study.¹⁰ In the 24-Unit Study, screening data were obtained from equipment containing organic compounds at 24 individual chemical process units representing a cross-section of the SOCFI. In the Six-Unit Maintenance Study, bagging data were collected from six of the process units within the 24-Unit Study to determine the effect of maintenance on equipment leak emissions. Most of the bagging

data were collected from equipment with screening values above 1,000 ppmv. As part of the Six-Unit Maintenance Study, correlations were developed for light liquid pumps, gas valves, and light liquid valves.

The original SOCFI average emission factors were first presented in the document "Fugitive Emission Sources of Organic Compounds--Additional Information on Emissions, Emission Reductions, and Costs."⁶ This document is referred to as the Fugitive Emissions Additional Information Document (AID). In the Fugitive Emissions AID, the data from the Refinery Assessment Study were further analyzed to develop "leak/no leak" emission factors. (A "leak" was defined as a screening value greater than or equal to 10,000 ppmv.) With the exception of the factor for gas valves, the original SOCFI average emission factors were developed using (1) the leak/no-leak emission factors developed from the Refinery Assessment Study data, and (2) the leak frequencies from the SOCFI 24-Unit Study screening value data set. This approach was based on statistical comparisons that indicated that the most significant characteristic that distinguished equipment in SOCFI facilities from that in refineries was not the leak rate for a given screening value, but rather the fraction of equipment that had screening values greater than or equal to 10,000 ppmv.

Thus, the following equation was used to calculate the original SOCFI average emission factors:

$$\text{SOCFI Average Factor} = (F \times \text{RLF}) + (1 - F) \times \text{RNLF}$$

where:

F = Fraction of sources from the 24-Unit Study that screened greater than or equal to 10,000 ppmv;

RLF = Refinery leaking emission factor; and

RNLF = Refinery non-leaking emission factor.

For gas valves, the previously collected data suggested that for a given screening value the leak rate at a SOCFI facility was

not statistically equivalent to the leak rate at a refinery. Therefore, data from the Six-Unit Maintenance Study were used to develop the gas valve average emission factor.

2.2.2.5 Revised SOCFI Emission Factors and Correlations. In 1987 and 1988, screening data were obtained from 19 ethylene oxide and butadiene producers, and, in 1990, bagging data were collected from 16 of these process units. Screening and bagging data were collected from light liquid pumps, gas valves, light liquid valves, and connectors. A specific goal of the program was to bag equipment that had screening values less than 1,000 ppmv. The bagging data were combined with bagging data previously collected in the Six-Unit Maintenance Study, and this combined bagging data set was used to revise the SOCFI correlations. Likewise, the new screening data were combined with screening data previously collected in the 24-Unit Study, and this combined screening data set was used with the revised correlations to generate new SOCFI emission factors.

Appendix B.2 contains more detailed information on how the revised SOCFI correlations and emission factors were developed.

2.3 APPROACHES FOR ESTIMATING EQUIPMENT LEAK EMISSIONS

In this section, each of the approaches for estimating equipment leak emissions are discussed. The description of each approach focuses on the basic method for estimating TOC emissions. Each of the approaches are demonstrated in example calculations contained in appendix A. Special topics at the end of the chapter have been included to address how to estimate VOC emissions when some of the organic compounds in the stream are not classified as VOC's and also how to speciate emissions for individual chemicals from equipment containing a mixture.

2.3.1 Average Emission Factor Approach

One accepted approach for estimating emissions allows use of average emission factors developed by the EPA in combination with unit-specific data that are relatively simple to obtain. These data include: (1) the number of each type of component in a unit (valve, connector, etc.), (2) the service each component is in (gas, light liquid, or heavy liquid), (3) the TOC concentration

of the stream (and VOC or HAP concentrations if speciation is to be performed), and (4) the time period each component was in that service. The average emission factors for SOCFI process units, refineries, marketing terminals, and oil and gas production operations are presented in tables 2-1, 2-2, 2-3, and 2-4 respectively. The SOCFI, marketing terminal, and oil and gas production operations average emission factors predict total organic compound emission rates, whereas the refinery average factors predict non-methane organic compound emission rates. Note that limited data has been collected on the leak rate of agitators, and, until additional data are collected for emissions from agitator seals, the average factor for light liquid pump seals can be used to estimate emissions from agitators.

Although the average emission factors are in units of kilogram per hour per individual source, it is important to note that these factors are most valid for estimating emissions from a population of equipment. The average factors are not intended to be used for estimating emissions from an individual piece of equipment over a short time period (i.e., 1 hour).

To estimate emissions using the Average Emission Factor Approach, the concentration of TOC in weight fraction within the equipment is needed because equipment with higher TOC concentrations tend to have higher TOC leak rates. When using the Average Emission Factor Approach, equipment should be grouped into "streams" where all the equipment within the stream have approximately the same TOC weight fraction.

To apply the average emission factors, use the following equation to estimate TOC mass emissions from all of the equipment in a stream of a given equipment type:

$$E_{\text{TOC}} = F_A \times W_{\text{TOC}} \times N$$

where:

E_{TOC} = Emission rate of TOC from all equipment in the stream of a given equipment type (kg/hr);

TABLE 2-1. SOCMI AVERAGE EMISSION FACTORS

Equipment type	Service	Emission factor ^a (kg/hr/source)
Valves	Gas	0.00597
	Light liquid	0.00403
	Heavy liquid	0.00023
Pump seals ^b	Light liquid	0.0199
	Heavy liquid	0.00862
Compressor seals	Gas	0.228
Pressure relief valves	Gas	0.104
Connectors	All	0.00183
Open-ended lines	All	0.0017
Sampling connections	All	0.0150

^aThese factors are for total organic compound emission rates.

^bThe light liquid pump seal factor can be used to estimate the leak rate from agitator seals.

TABLE 2-2. REFINERY AVERAGE EMISSION FACTORS^a

Equipment type	Service	Emission factor (kg/hr/source) ^b
Valves	Gas	0.0268
	Light liquid	0.0109
	Heavy liquid	0.00023
Pump seals ^c	Light liquid	0.114
	Heavy liquid	0.021
Compressor seals	Gas	0.636
Pressure relief valves	Gas	0.16
Connectors	All	0.00025
Open-ended lines	All	0.0023
Sampling connections	All	0.0150

^aSource: Reference 2.

^bThese factors are for non-methane organic compound emission rates.

^cThe light liquid pump seal factor can be used to estimate the leak rate from agitator seals.

TABLE 2-3. MARKETING TERMINAL AVERAGE EMISSION FACTORS

Equipment type	Service	Emission factor (kg/hr/source) ^a
Valves	Gas	1.3E-05
	Light Liquid	4.3E-05
Pump seals	Gas	6.5E-05
	Light Liquid	5.4E-04
Others (compressors and others) ^b	Gas	1.2E-04
	Light Liquid	1.3E-04
Fittings (connectors and flanges) ^c	Gas	4.2E-05
	Light Liquid	8.0E-06

^aThese factors are for total organic compound emission rates (including non-VOC's such as methane and ethane).

^bThe "other" equipment type should be applied for any equipment type other than fittings, pumps, or valves.

^c"Fittings" were not identified as flanges or non-flanged connectors; therefore, the fitting emissions were estimated by averaging the estimates from the connector and the flange correlation equations.

TABLE 2-4. OIL AND GAS PRODUCTION OPERATIONS AVERAGE EMISSION FACTORS (kg/hr/source)

Equipment Type	Service ^a	Emission Factor (kg/hr/source) ^b
Valves	Gas	4.5E-03
	Heavy Oil	8.4E-06
	Light Oil	2.5E-03
	Water/Oil	9.8E-05
Pump seals	Gas	2.4E-03
	Heavy Oil	NA
	Light Oil	1.3E-02
	Water/Oil	2.4E-05
Others ^c	Gas	8.8E-03
	Heavy Oil	3.2E-05
	Light Oil	7.5E-03
	Water/Oil	1.4E-02
Connectors	Gas	2.0E-04
	Heavy Oil	7.5E-06
	Light Oil	2.1E-04
	Water/Oil	1.1E-04
Flanges	Gas	3.9E-04
	Heavy Oil	3.9E-07
	Light Oil	1.1E-04
	Water/Oil	2.9E-06
Open-ended lines	Gas	2.0E-03
	Heavy Oil	1.4E-04
	Light Oil	1.4E-03
	Water/Oil	2.5E-04

^aWater/Oil emission factors apply to water streams in oil service with a water content greater than 50%, from the point of origin to the point where the water content reaches 99%. For water streams with a water content greater than 99%, the emission rate is considered negligible.

^bThese factors are for total organic compound emission rates (including non-VOC's such as methane and ethane) and apply to light crude, heavy crude, gas plant, gas production, and off shore facilities. "NA" indicates that not enough data were available to develop the indicated emission factor.

^cThe "other" equipment type was derived from compressors, diaphragms, drains, dump arms, hatches, instruments, meters, pressure relief valves, polished rods, relief valves, and vents. This "other" equipment type should be applied for any equipment type other than connectors, flanges, open-ended lines, pumps, or valves.

F_A = Applicable average emission factor for the equipment type (kg/hr/source);

FOR REFINERIES ONLY: The emission factor " F_A " must be adjusted to account for all organic compounds in the stream because the refinery factors are only valid for non-methane organic compounds (percents up to a maximum of 10 percent by weight methane are permitted):

$$F_A = F_A \times \frac{WF_{TOC}}{WF_{TOC} - WF_{methane}} ;$$

WF_{TOC} = Average weight fraction of TOC in the stream;

$WF_{methane}$ = Average weight fraction of methane in the stream; and

N = Number of pieces of equipment of the applicable equipment type in the stream.

Note that the emission factor " F_A " is defined differently for refineries than for SOCOMI, marketing terminals, or oil and gas production operations when calculating TOC mass emissions. It is necessary to adjust the " F_A " term when applied to refineries, because when the refinery factors were developed, the methane was subtracted out of the organic total. Adjusting the " F_A " term for refineries is a way to correct for this. Two guidelines when correcting the " F_A " term when applied to refineries are as follows:

- The correction should only be applied to equipment containing a mixture of organics and methane; and
- The maximum correction for the methane weight fraction should not exceed 0.10, even if the equipment contains greater than 10 weight percent methane. (This reflects that equipment in the Refinery Assessment Study^{1,2} typically contained 10 weight percent or less methane).

Thus, at a SOCOMI process unit, if there were 100 gas valves in a stream containing, on average, 90 weight percent TOC and 10 weight percent water vapor, emissions would be calculated as follows:

$$\begin{aligned}
E_{\text{TOC}} &= F_A \times W_{\text{F}_{\text{TOC}}} \times N \\
&= 0.00597 \text{ kg/hr/gas valve} \times 0.9 \times 100 \text{ gas valves} \\
&= 0.54 \text{ kg/hr of VOC from gas valves in the stream}
\end{aligned}$$

At a refinery, if there were 100 gas valves in a stream that, on average, contained 80 weight percent non-methane TOC, 10 weight percent water vapor, and 10 weight percent methane (thus, the TOC weight percent would be 90), emissions would be calculated using the above equation as follows:

$$\begin{aligned}
E_{\text{TOC}} &= F_A \times \frac{W_{\text{F}_{\text{TOC}}}}{W_{\text{F}_{\text{TOC}}} - W_{\text{F}_{\text{methane}}}} \times W_{\text{F}_{\text{TOC}}} \times N \\
&= 0.0268 \text{ kg/hr/gas valve} \times (0.9/0.9-0.1) \times 0.9 \times \\
&\quad 100 \text{ gas valves} \\
&= 2.71 \text{ kg/hr of VOC from gas valves in the stream}
\end{aligned}$$

If there are several streams at a process unit, the total TOC emission rate for an equipment type is the sum of emissions from each of the streams. The total emission rates for all of the equipment types are summed to generate the process unit total TOC emission rate from leaking equipment.

Assuming all of the organic compounds in the stream are classified as VOC's, the total VOC emission for each stream is calculated as the sum of TOC emissions associated with each specific equipment type in the stream. Section 2.4.6 discusses an adjustment that can be made to predict the VOC emission rate if some of the organic compounds in the stream are not classified as VOC's (such as methane and ethane).

As mentioned earlier, the average emission factors are not intended to provide an accurate estimate of the emission rate from a single piece of equipment. Rather, the average factors are more appropriately applied to the estimation of emissions from populations of equipment. Data indicate that the range of possible leak rates from individual pieces of equipment spans

several orders of magnitude. As a result, the majority of total emissions from a population of equipment at any given time will normally occur from a small percentage of the total equipment. The average emission factors account for the span of possible leak rates, but, as a result, they are not necessarily an accurate indication of the mass emission rate from an individual piece of equipment.

Furthermore, the average emission factors do not reflect different site-specific conditions among process units within a source category. Site-specific factors can have considerable influence on leak rates from equipment. Nevertheless, in the absence of screening data, the average emission factors do provide an indication of equipment leak emission rates from equipment in a process unit.

2.3.2 Screening Ranges Approach

The Screening Ranges Approach (formerly known as the leak/no-leak approach) offers some refinement over the Average Emission Factor Approach, thereby allowing some adjustment for individual unit conditions and operation. This approach is included in this section primarily to aid in the analysis of old datasets which were collected for older regulations that used 10,000 ppmv as the leak definition. This approach and the other two remaining approaches require that screening data be collected for the equipment in the process unit. The screening data are an indication of leak rates. When applying this approach, it is assumed that components having screening values greater than 10,000 ppmv have a different average emission rate than components with screening values less than 10,000 ppmv.

This approach may be applied when screening data are available as either "greater than or equal to 10,000 ppmv" or as "less than 10,000 ppmv." Emission factors for SOCFI, refineries, marketing terminals, and oil and gas production operations for these two ranges of screening values are presented in tables 2-5, 2-6, and 2-7, and 2-8, respectively. As with the average factors, the SOCFI, marketing terminal, and oil and gas production operations screening range factors predict total

TABLE 2-5. SOCFI SCREENING RANGES EMISSION FACTORS

Equipment type	Service	≥10,000 ppmv Emission factor (kg/hr/source) ^a	<10,000 ppmv Emission factor (kg/hr/source) ^a
Valves	Gas	0.0782	0.000131
	Light liquid	0.0892	0.000165
	Heavy liquid	0.00023	0.00023
Pump seals ^b	Light liquid	0.243	0.00187
	Heavy liquid	0.216	0.00210
Compressor seals	Gas	1.608	0.0894
Pressure relief valves	Gas	1.691	0.0447
Connectors	All	0.113	0.0000810
Open-ended lines	All	0.01195	0.00150

^aThese factors are for total organic compound emission rates.

^bThe light liquid pump seal factors can be applied to estimate the leak rate from agitator seals.

TABLE 2-6. REFINERY SCREENING RANGES EMISSION FACTORS^a

Equipment type	Service	≥10,000 ppmv Emission factor (kg/hr/source) ^b	<10,000 ppmv Emission factor (kg/hr/source) ^b
Valves	Gas	0.2626	0.0006
	Light liquid	0.0852	0.0017
	Heavy liquid	0.00023	0.00023
Pump seals ^c	Light liquid	0.437	0.0120
	Heavy liquid	0.3885	0.0135
Compressor seals	Gas	1.608	0.0894
Pressure relief valves	Gas	1.691	0.0447
Connectors	All	0.0375	0.00006
Open-ended lines	All	0.01195	0.00150

^aSource: Reference 6.

^bThese factors are for non-methane organic compound emission rates.

^cThe light liquid pump seal factors can be applied to estimate the leak rate from agitator seals.

TABLE 2-7. MARKETING TERMINAL SCREENING RANGES EMISSION FACTORS

Equipment type	Service	≥10,000 ppmv Emission factor (kg/hr/source) ^a	<10,000 ppmv Emission factor (kg/hr/source) ^a
Valves	Gas	NA	1.3E-05
	Light Liquid	2.3E-02	1.5E-05
Pump seals	Light liquid	7.7E-02	2.4E-04
Other (compressors and others) ^b	Gas	NA	1.2E-04
	Light liquid	3.4E-02	2.4E-05
Fittings (connectors and flanges) ^c	Gas	3.4E-02	5.9E-06
	Light liquid	6.5E-03	7.2E-06

^aThese factors are for total organic compound emission rates (including non-VOC's such as methane and ethane). "NA" indicates that not enough data were available to develop the indicated emission factor.

^bThe "other" equipment type should be applied for any equipment type other than fittings, pumps, or valves.

^c"Fittings" were not identified as flanges or connectors; therefore, the fitting emissions were estimated by averaging the estimates from the connector and the flange correlation equations.

TABLE 2-8. OIL AND GAS PRODUCTION OPERATIONS SCREENING RANGES
EMISSION FACTORS

Equipment type	Service ^b	≥10,000 ppmv Emission factor (kg/hr/source) ^a	<10,000 ppmv Emission factor (kg/hr/source) ^a
Valves	Gas	9.8E-02	2.5E-05
	Heavy Oil	NA	8.4E-06
	Light Oil	8.7E-02	1.9E-05
	Water/Oil	6.4E-02	9.7E-06
Pump seals	Gas	7.4E-02	3.5E-04
	Heavy Oil	NA	NA
	Light Oil	1.0E-01	5.1E-04
	Water/Oil	NA	2.4E-05
Others ^c	Gas	8.9E-02	1.2E-04
	Heavy Oil	NA	3.2E-05
	Light Oil	8.3E-02	1.1E-04
	Water/Oil	6.9E-02	5.9E-05
Connectors	Gas	2.6E-02	1.0E-05
	Heavy Oil	NA	7.5E-06
	Light Oil	2.6E-02	9.7E-06
	Water/Oil	2.8E-02	1.0E-05
Flanges	Gas	8.2E-02	5.7E-06
	Heavy Oil	NA	3.9E-07
	Light Oil	7.3E-02	2.4E-06
	Water/Oil	NA	2.9E-06
Open-ended lines	Gas	5.5E-02	1.5E-05
	Heavy Oil	3.0E-02	7.2E-06
	Light Oil	4.4E-02	1.4E-05
	Water/Oil	3.0E-02	3.5E-06

^aThese factors are for total organic compound emission rates (including non-VOC's such as methane and ethane) and apply to light crude, heavy crude, gas plant, gas production, and offshore facilities. "NA" indicates that not enough data were available to develop the indicated emission factor.

^bWater/Oil emission factors apply to water streams in oil service with a water content greater than 50%, from the point of origin to the point where the water content reaches 99%. For water streams with a water content greater than 99%, the emission rate is considered negligible.

^cThe "other" equipment type was derived from compressors, diaphragms, drains, dump arms, hatches, instruments, meters, pressure relief valves, polished rods, relief valves, and vents. This "other" equipment type should be applied for any equipment type other than connectors, flanges, open-ended lines, pumps, or valves.

organic compound emissions, whereas the refinery screening range factors predict non-methane organic compound emissions. Note that there are not screening range factors for sampling connections because emissions from sampling connections occur when the line is purged, and, thus, are independent of any screening value. Also, as with the average factors, the screening range factors for light liquid pumps can be applied to agitators.

The Screening Ranges Approach is applied in a similar manner as the Average Emission Factor Approach in that equipment counts are multiplied by the applicable emission factor. Also, for refineries, the screening range emission factors must be adjusted for methane in the equipment because when the refinery factors were developed, the methane was subtracted out of the organic total.

To calculate TOC emissions using the Screening Ranges Approach, the following equation is used:

$$E_{\text{TOC}} = (F_G \times N_G) + (F_L \times N_L)$$

where:

E_{TOC} = TOC emission rate for an equipment type (kg/hr);

F_G = Applicable emission factor for sources with screening values greater than or equal to 10,000 ppmv (kg/hr/source);

FOR REFINERIES ONLY: The emission factor " F_G " must be adjusted to account for all organic compounds in the stream because the refinery factors are only valid for non-methane organic compounds (percents up to a maximum of 10 percent by weight methane are permitted):

$$F_G = F_G \times \frac{WP_{\text{TOC}}}{WP_{\text{TOC}} - WP_{\text{methane}}} ;$$

WP_{TOC} = Average weight percent of TOC in the stream;

- WP_{methane} = Average weight percent of methane in the stream;
- N_G = Equipment count (specific equipment type) for sources with screening values greater than or equal to 10,000 ppmv;
- F_L = Applicable emission factor for sources with screening values less than 10,000 ppmv (kg/hr/source)

FOR REFINERIES ONLY: The emission factor " F_L " must be adjusted to account for all organic compounds in the stream because the refinery factors are only valid for non-methane organic compounds (percents up to a maximum of 10 percent by weight methane are permitted):

$$F_L = F_L \times \frac{WP_{\text{TOC}}}{WP_{\text{TOC}} - WP_{\text{methane}}} ; \text{ and}$$

- N_L = Equipment count (specific equipment type) for sources with screening values less than 10,000 ppmv.

Assuming all of the organic compounds in the stream are classified as VOC's, the total VOC emission for each stream is calculated as the sum of TOC emissions associated with each specific equipment type in the stream. Section 2.4.6 discusses an adjustment that can be made to predict the VOC emission rate if some of the organic compounds in the stream are not classified as VOC's (such as methane and ethane).

The screening range emission factors are a better indication of the actual leak rate from individual equipment than the average emission factors. Nevertheless, available data indicate that measured mass emission rates can vary considerably from the rates predicted by use of these factors.

2.3.3 EPA Correlation Approach

This approach offers an additional refinement to estimating emissions from equipment leaks by providing an equation to predict mass emission rate as a function of screening value for a particular equipment type. Correlations developed by the EPA relating screening values to mass emission rates for SOCM I

process units and for petroleum industry process units are presented in tables 2-9 and 2-10, respectively. Correlations for the petroleum industry apply to refineries, marketing terminals and oil and gas production operations. Figures 2-2 through 2-5 plot the correlations. Both the SOCFI and petroleum industry correlations predict total organic compound emission rates. Appendix B.1 contains additional information on the general development of correlation equations. Additionally, appendix B.2 contains information about the development of the SOCFI correlations and appendix C contains information about the development of the petroleum industry correlations.

The EPA Correlation Approach is preferred when actual screening values are available. Correlations can be used to estimate emissions for the entire range of non-zero screening values, from the highest potential screening value to the screening value that represents the minimum detection limit of the monitoring device. This approach involves entering the non-zero, non-pegged screening value into the correlation equation, which predicts the TOC mass emission rate based on the screening value. Default zero emission rates are used for screening values of zero ppmv and pegged emission rates are used for "pegged" screening values (the screening value is beyond the upper limit measured by the portable screening device).

Correlations for SOCFI are available for (1) gas valves; (2) light liquid valves; (3) connectors; and (4) light liquid pump seals. Correlations for the petroleum industry are available for (1) valves; (2) connectors; (3) pumps; (4) flanges; (5) open-ended lines; and (6) "others" (derived from instruments, loading arms, pressure relief valves, stuffing boxes, and vents).

Limited bagging data for compressors and pressure relief devices have been obtained at SOCFI plants. However, because statistical tests performed as part of the Refinery Assessment Study² indicated that emissions from light liquid pumps, compressors, and pressure relief valves could be expressed with a single correlation, until additional data are collected, the SOCFI equation for light liquid pump seals can be applied to

TABLE 2-9. SOCMI LEAK RATE/SCREENING VALUE CORRELATIONS

Equipment type	Correlation ^{a,b}
Gas valves	Leak rate (kg/hr) = $1.87E-06 \times (SV)^{0.873}$
Light liquid valves	Leak rate (kg/hr) = $6.41E-06 \times (SV)^{0.797}$
Light liquid pumps ^c	Leak rate (kg/hr) = $1.90E-05 \times (SV)^{0.824}$
Connectors	Leak rate (kg/hr) = $3.05E-06 \times (SV)^{0.885}$

^aSV = Screening value in ppmv.

^bThese correlations predict total organic compound emission rates.

^cThe correlation for light liquid pumps can be applied to compressor seals, pressure relief valves, agitator seals, and heavy liquid pumps.

TABLE 2-10. PETROLEUM INDUSTRY LEAK RATE/SCREENING VALUE CORRELATIONS^a

Equipment type/service	Correlation ^{b,c}
Valves/all	Leak rate (kg/hr) = $2.29E-06 \times (SV)^{0.746}$
Pump seals/all	Leak rate (kg/hr) = $5.03E-05 \times (SV)^{0.610}$
Others ^d	Leak rate (kg/hr) = $1.36E-05 \times (SV)^{0.589}$
Connectors/all	Leak rate (kg/hr) = $1.53E-06 \times (SV)^{0.735}$
Flanges/all	Leak rate (kg/hr) = $4.61E-06 \times (SV)^{0.703}$
Open-ended lines/all	Leak rate (kg/hr) = $2.20E-06 \times (SV)^{0.704}$

^aThe correlations presented in this table are revised petroleum industry correlations.

^bSV = Screening value in ppmv.

^cThese correlations predict total organic compound emission rates (including non-VOC's such as methane and ethane).

^dThe "other" equipment type was derived from instruments, loading arms, pressure relief valves, stuffing boxes, and vents. This "other" equipment type should be applied to any equipment type other than connectors, flanges, open-ended lines, pumps, or valves.

SOCMI Correlation Curves

Screening Values 0-1,000 ppmv

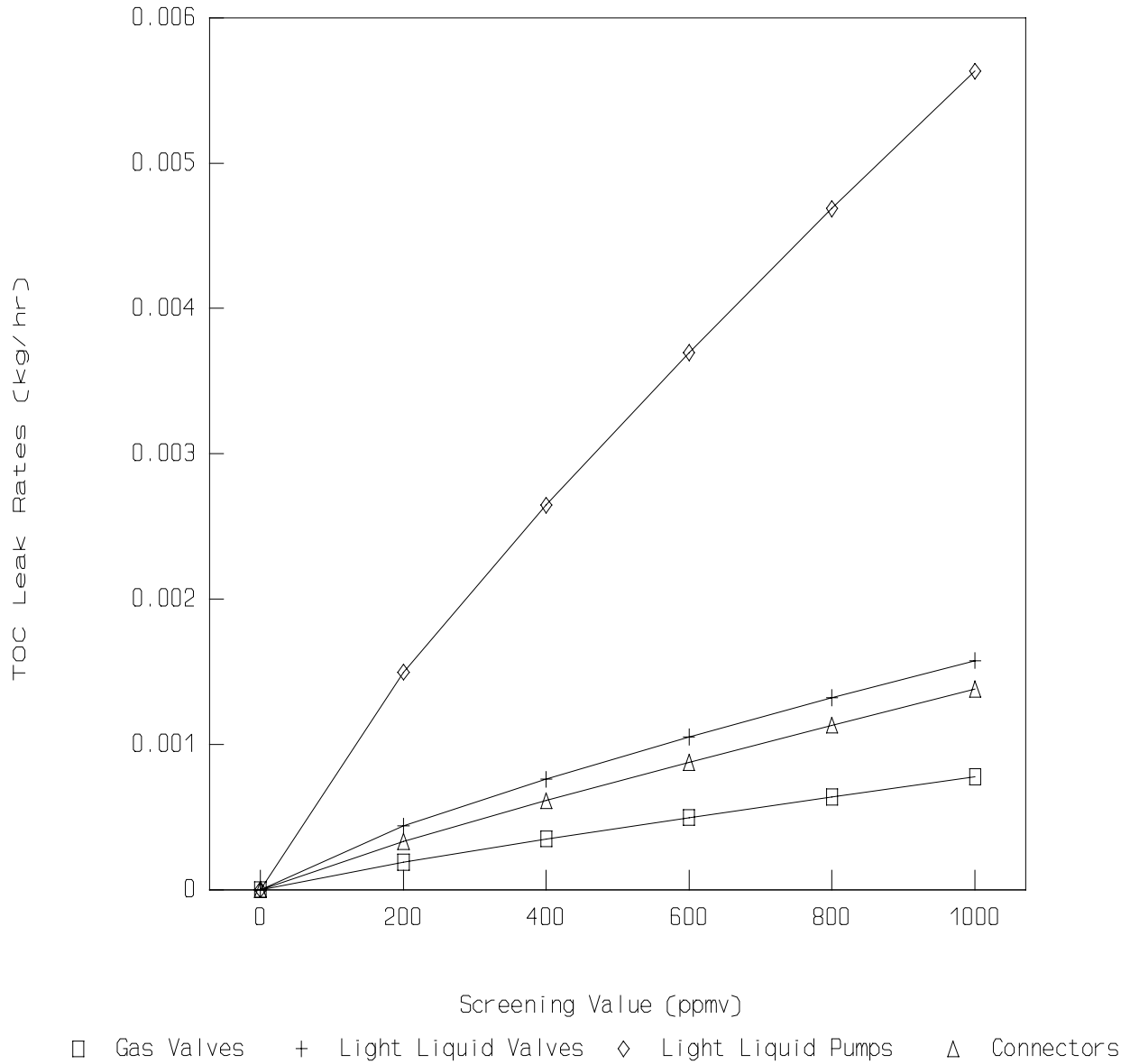

Figure 2-2. SOCMI Correlations relating total organic compound (TOC) leak rate to screening value:
0 - 1,000 ppmv

SOCMI Correlation Curves

Screening Values 1,000-1,000,000 ppmv

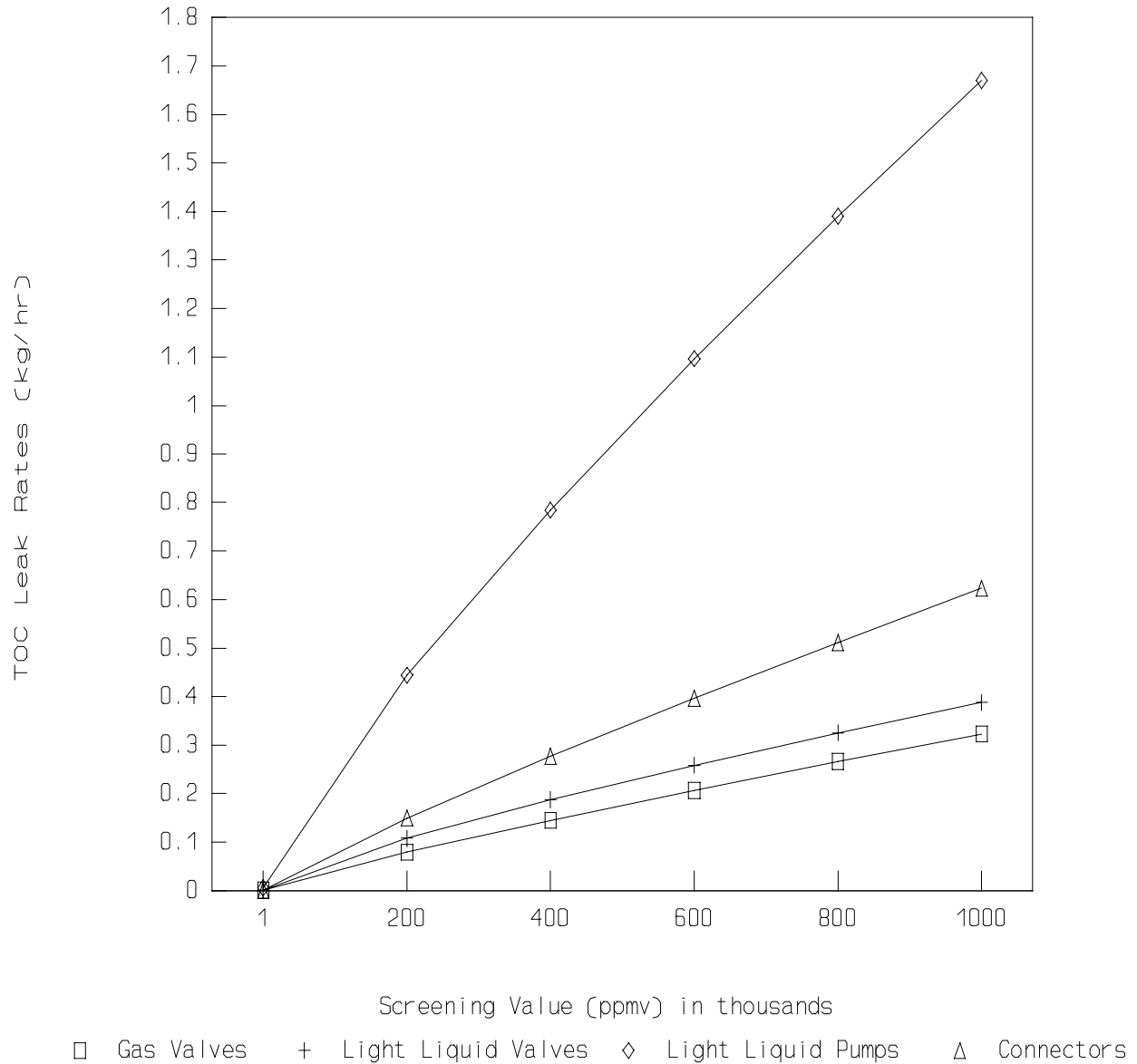

Figure 2-3. SOCMI Correlations relating total organic compound (TOC) leak rate to screening value: 1,000 - 1,000,000 ppmv

Petroleum Industry Correlation Curves

Screening Values 0 – 1,000 ppmv

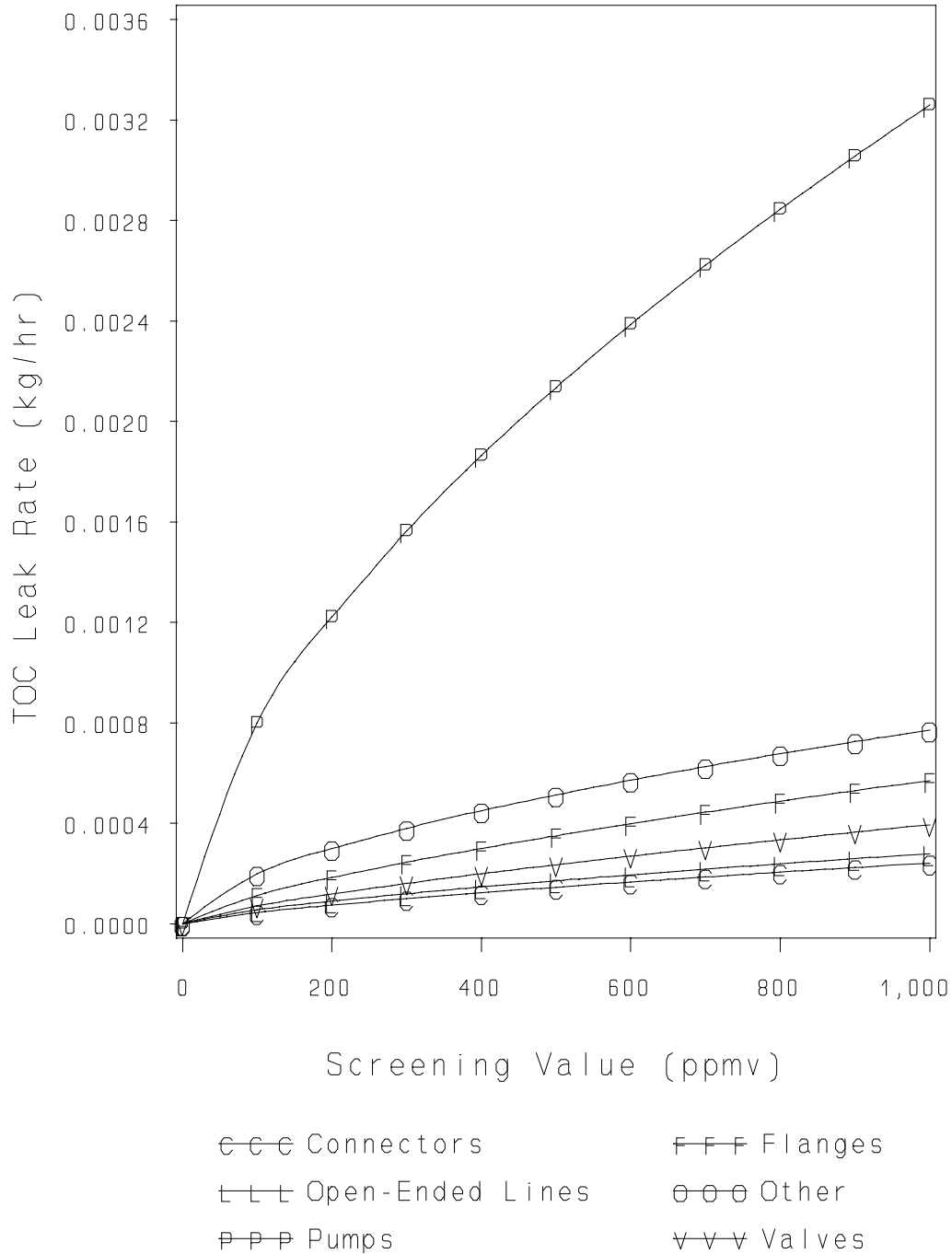

Figure 2-4. Petroleum Industry Correlations relating total organic compound (TOC) leak rate to screening value: 1,000 - 1,000,000 ppmv

Petroleum Industry Correlation Curves

Screening Values 0 – 1,000,000 ppmv

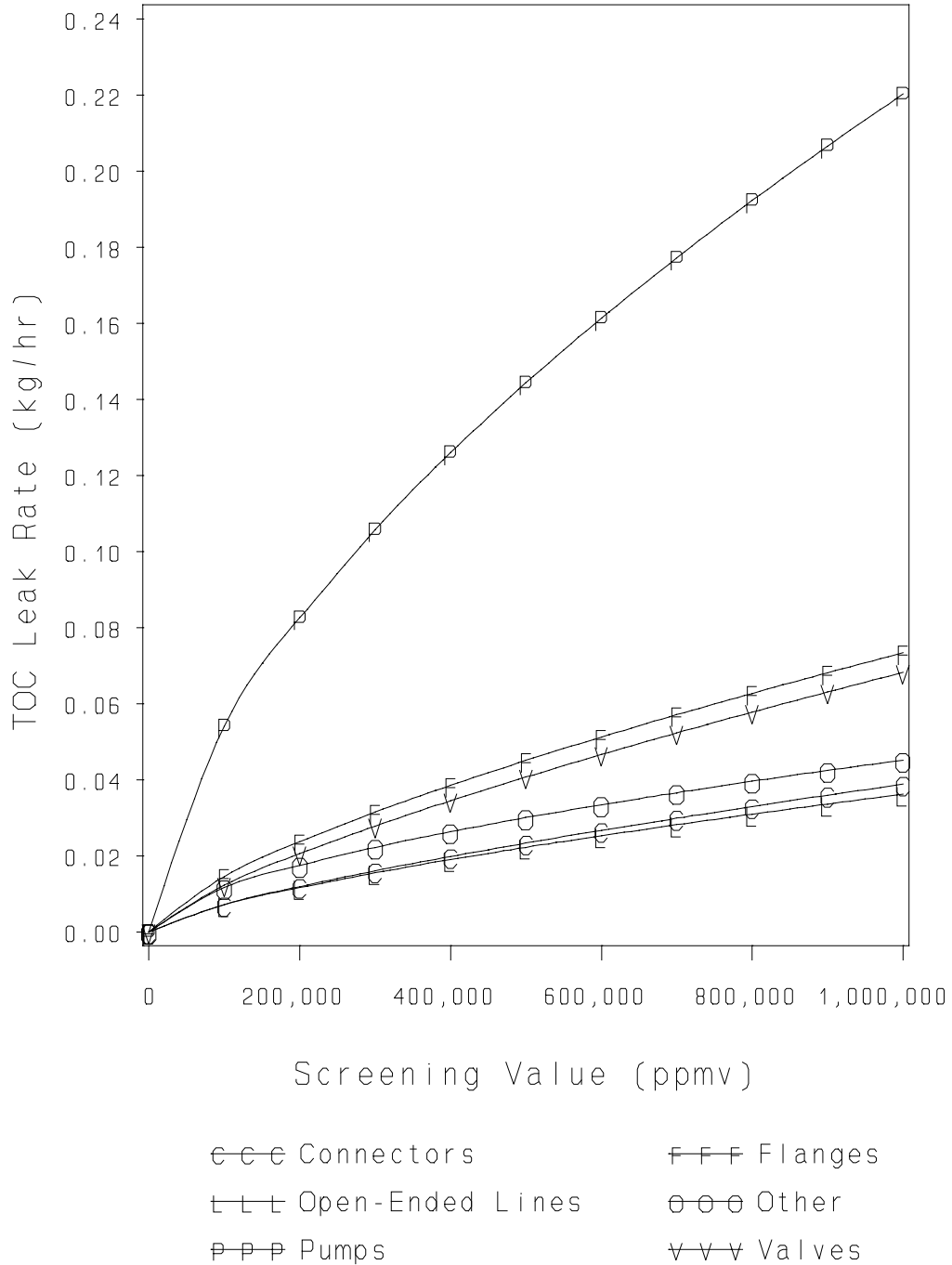

Figure 2-5. Petroleum Industry Correlations relating total organic compound (TOC) leak rate to screening value: 1,000 - 1,000,000 ppmv

estimate emissions for compressor seals and pressure relief valves in SOCFI process units. Because bagging data were limited and the frequency of occurrence of some equipment types was small, a correlation for an "other" equipment type was developed for the petroleum industry correlations to apply to any equipment type other than connectors, flanges, open-ended lines, pumps, or valves.

Bagging data for agitator seals at petroleum industry and SOCFI process units are unavailable at this time. Compared to those equipment types that have correlations, agitators most closely resemble light liquid pumps, and, for this reason, the applicable light liquid pump correlation can be used to estimate agitator emissions. Similarly, the SOCFI light liquid pump correlation can be used to estimate emissions from SOCFI heavy liquid pumps.

The "default-zero" leak rate is the mass emission rate associated with a screening value of zero. (Note that any screening value that is less than or equal to ambient [background] concentration is considered a screening value of zero.) The correlations mathematically predict zero emissions for zero screening values. However, data collected by the EPA show this prediction to be incorrect. Mass emissions have been measured from equipment having a screening value of zero. A specific goal when revising the SOCFI and petroleum industry correlations was to collect mass emissions data from equipment that had a screening value of zero. These data were used to determine a default-zero leak rate associated with equipment with zero screening values.

Table 2-11 lists the SOCFI default-zero leak rates and table 2-12 presents the petroleum industry default-zero leak rates for each of the equipment types with correlation equations. These default-zero leak rates are applicable only when the minimum detection limit of the portable monitoring instrument is 1 ppmv or less above background.

The portable monitoring device used to collect the default-zero data was sufficiently sensitive to indicate a

TABLE 2-11. DEFAULT-ZERO VALUES: SOCMI PROCESS UNITS

Equipment type	Default-zero emission rate (kg/hr/source) ^a
Gas valve	6.6E-07
Light liquid valve	4.9E-07
Light liquid pump ^b	7.5E-06
Connectors	6.1E-07

^aThe default zero emission rates are for total organic compounds (including non-VOC's such as methane and ethane).

^bThe light liquid pump default zero value can be applied to compressors, pressure relief valves, agitators, and heavy liquid pumps.

TABLE 2-12. DEFAULT-ZERO VALUES: PETROLEUM INDUSTRY

Equipment type/service	Default-zero emission rates ^{a,b} (kg/hr/source)
Valves/all	7.8E-06
Pump seals/all	2.4E-05
Others ^c /all	4.0E-06
Connectors/all	7.5E-06
Flanges/all	3.1E-07
Open-ended lines/all	2.0E-06

^aDefault zero emission rates were based on the combined 1993 refinery and marketing terminal data only (default zero data were not collected from oil and gas production facilities).

^bThese default zero emission rates are for total organic compounds (including non-VOC's such as methane and ethane).

^cThe "other" equipment type was developed from instruments, loading arms, pressure relief valves, stuffing boxes, vents, compressors, and dump lever arms. This "other" equipment type should be applied to any equipment type other than connectors, flanges, open-ended lines, pumps, or valves.

screening value of 1 ppmv or less. In cases where a monitoring instrument has a minimum detection limit greater than 1 ppmv, the default-zero leak rates presented in tables 2-11 and 2-12 are not applicable. For these cases, an alternative approach for determining a default-zero leak rate is to (1) determine one-half the minimum screening value of the monitoring instrument, and (2) enter this screening value into the applicable correlation to determine the associated default-zero leak rate.

The "pegged" emission rate is the mass emission rate associated with a screening value that has "pegged" the meter on the portable screening device (i.e. the screening value is beyond the upper limit measured by the portable screening device). In the case of a screening value pegged at 10,000 ppmv, a dilution probe should be used to extend the upper limit of the portable screening device to 100,000 ppmv. Thus, screening values can be reported up to 100,000 ppmv before pegging the instrument and the correlation equation can be used to estimate the mass emissions. However, in the case of previously-collected data or in the absence of a dilution probe, pegged readings of 10,000 ppmv are sometimes reported. In such cases, the 10,000 ppmv pegged emission rates can be used to estimate the mass emissions.

Table 2-13 presents the 10,000 ppmv and 100,000 ppmv pegged emission rates for SOCFI process units and table 2-14 presents the 10,000 ppmv and 100,000 ppmv pegged emission rates for petroleum industry process units. These pegged emission rates are to be used to estimate emissions when instrument readings are pegged and a dilution probe is not used.

Assuming all of the organic compounds in the equipment are classified as VOC's, total VOC emissions for each equipment type are calculated as the sum of emissions associated with each of the screening values. Section 2.4.6 discusses a correction that can be made to the predicted VOC emissions rate if some of the organic compounds in the equipment are not classified as VOC's (such as methane and ethane).

To summarize the correlation approach, each equipment piece with a screening value of zero is assigned the default-zero leak

TABLE 2-13. 10,000 PPMV AND 100,000 PPMV SCREENING VALUE PEGGED EMISSION RATES FOR SOCMI PROCESS UNITS

Equipment type	10,000 ppmv pegged emission rate (kg/hr/source) ^{a, b}	100,000 ppmv pegged emission rate (kg/hr/source) ^a
Gas valves	0.024	0.11
Light liquid valves	0.036	0.15
Light liquid pump seals ^b	0.14	0.62
Connectors	0.044	0.22

^aThe SOCMI pegged emission rates are for total organic compounds.

^bThe 10,000 ppmv pegged emission rate applies only when a dilution probe cannot be used or in the case of previously-collected data that contained screening values reported pegged at 10,000 ppmv.

^cThe light liquid pump seal pegged emission rates can be applied to compressors, pressure relief valves, and agitators.

TABLE 2-14. 10,000 ppmv and 100,000 PPMV SCREENING VALUE PEGGED EMISSION RATES FOR THE PETROLEUM INDUSTRY

Equipment type/service	10,000 ppmv pegged emission rate (kg/hr/source) ^{a, b}	100,000 ppmv pegged emission rate (kg/hr/source) ^a
Valves/all	0.064	0.140
Pump seals/all	0.074	0.160 ^c
Others ^d /all	0.073	0.110
Connectors/all	0.028	0.030
Flanges/all	0.085	0.084
Open-ended lines/all	0.030	0.079

^aThe petroleum industry pegged emission rates are for total organic compounds (including non-VOC's such as methane and ethane).

^bThe 10,000 ppmv pegged emission rate applies only when a dilution probe cannot be used or in the case of previously-collected data that contained screening values reported pegged at 10,000 ppmv. The 10,000 ppmv pegged emission rate was based on components screened at greater than or equal to 10,000 ppmv; however, in some cases, most of the data could have come from components screened at greater than 100,000 ppmv, thereby resulting in similar pegged emission rates for both the 10,000 and 100,000 pegged levels (e.g., connector and flanges).

^cOnly 2 data points were available for the pump seal 100,000 pegged emission rate; therefore the ratio of the pump seal 10,000 pegged emission rate to the overall 10,000 ppmv pegged emission rate was multiplied by the overall 10,000 ppmv pegged emission rate to approximate the pump 100,000 ppmv pegged emission rate.

^dThe "other" equipment type was developed from instruments, loading arms, pressure relief valves, stuffing boxes, vents, compressors, dump lever arms, diaphragms, drains, hatches, meters, and polished rods. This "other" equipment type should be applied to any equipment type other than connectors, flanges, open-ended lines, pumps, and valves.

rate. For all equipment with a non-zero screening value, the screening value associated with each individual equipment piece is entered into the applicable correlation to predict emissions. *It should be noted that each individual screening value must be entered into the correlation to predict emissions for an equipment piece. Do not average screening values and then enter the average value into the correlation to estimate emissions.* Finally, each equipment piece with a screening value reported as pegged is assigned the appropriate pegged emission rate.

2.3.4 Unit-Specific Correlation Approach

To develop unit-specific correlations screening value and corresponding mass emissions data (i.e., bagging data) must be collected from process unit equipment. (See chapter 4.0 for a detailed discussion on the procedures for bagging equipment.) The equipment selected for bagging should be screened at the time of bagging. The mass emissions rate determined by bagging, and the associated screening value, can then be used to develop a leak rate/screening value relationship (i.e., correlation) for that specific equipment type in that process unit. The correlations must be developed on a process unit basis to minimize the error associated with differing leak rate characteristics between units.

If a unit-specific correlation is developed, as long as the procedures for bagging discussed in chapter 4.0 are followed, it is not necessary to demonstrate that the correlation is statistically different from the EPA correlation for it to be applied. However, before developing unit-specific correlations, it may be desirable to evaluate the validity of the EPA correlations to a particular process unit. As few as four leak rate measurements of a particular equipment type in a particular service can be adequate for this purpose. The measured emission rates can be compared with the rates that would be predicted by the EPA correlations to evaluate whether or not the EPA correlations provide reasonable mass emission estimates. A simple method of comparison is to determine if measured emission rates are consistently less than or greater than what would be

predicted by the EPA correlation. If there is a consistent trend, such as all of the measured leak rates being lower than the rate predicted by the EPA correlation, the EPA correlation may not provide reasonable emission estimates for the process unit.

A more formal comparison is the Wilcoxon signed-rank test. This test can be performed by comparing the logarithm of the measured mass emission rates to the logarithm of the corresponding rates predicted by the EPA correlation. The absolute magnitude of the differences are then ranked (e.g., the pair with the smallest difference is assigned a rank of 1, the pair with the next smallest difference a rank of 2, etc.), and the sum of the ranks associated with positive differences is computed. For example, if four bags were measured and they each predicted higher mass emission rates than the EPA correlation, the value of the sum of the ranks associated with those pairs with positive differences would equal:

$$1 + 2 + 3 + 4 = 10$$

On the other hand, if four bags were measured and three predicted higher mass emission rates than the EPA correlation, but the one with the greatest absolute difference predicted a lower rate than the EPA correlation, then the sum of the positive ranks would equal:

$$1 + 2 + 3 = 6. \quad (\text{Note: } \textit{The sum of the negative ranks would equal 4}).$$

The value of the sum of the positive ranks can be compared to given values on statistical tables to evaluate if there are statistically significant differences between the measured rates and the rates predicted by the EPA correlation.

However the comparison is performed, in cases where the EPA correlations provide an adequate estimate of emissions, then the potential increase in accuracy obtained by developing

unit-specific correlations may not be worth the effort. Consideration should also be given to the typical screening value measured at a process unit. If a process unit normally has very low screening values, then the difference between the sum of unit equipment leak emissions predicted by a unit-specific correlation and the EPA correlation will likely be relatively small.

In developing new correlations, a minimum number of leak rate measurements and screening value pairs must be obtained according to the following methodology. First, equipment at the process unit is screened so that the distribution of screening values at the unit is known. Then, mass emissions data must be collected from individual sources that have screening values distributed over the entire range. The criteria for choosing these sources is as follows. For each equipment type (i.e., valves, pumps, etc.) and service (i.e., gas, light liquid, etc.), a random sample of a minimum of six components should be chosen for bagging from each of the following screening value ranges:

Screening Value Range (ppmv)

- 1 - 100
- 101 - 1,000
- 1,001 - 10,000
- 10,001 - 100,000
- > 100,000

The requirement of six bags per screening value range is based on the EPA experience with bagging components. There are two primary reasons for the above requirement: (1) to be confident in the representativeness of the data, and (2) to accurately reflect the range of possible mass emission rates associated with a given screening value. The importance of the first reason is self-evident: The more data collected the better the representativeness. The importance of the second reason is that a given screening value does not necessarily have a "true" emissions rate. For a single screening value, the mass emissions may range over several orders of magnitude depending upon several

factors, including the equipment type (i.e., gate valve versus ball valve versus plug valve, etc.) and operating parameters (i.e., chemical handled, temperature, pressure, etc.). This range of possible mass emission rates is accounted for when the correlation is developed (see discussion on the scale bias correction factor), and it is important to obtain enough data to accurately reflect the range. If six sources are not available in a particular screening value range, additional sources from the nearest range should be tested so that a minimum of 30 emission rate/screening value pairs are obtained for each source type. If 30 or more bags are collected, the process unit-specific correlation can be used to estimate emissions across the entire range of screening values (1 to 1,000,000 ppmv).

In some cases, it may be desirable to develop a correlation with fewer than 30 bags. This can be accomplished by developing a correlation that is not valid across the entire range of screening values. Two alternatives are available: (1) to develop a correlation valid for screening values ranging from 1 to 100,000 ppmv, or (2) to develop a correlation valid for screening values ranging from 1 to 10,000 ppmv. These alternatives may be preferable for process units with equipment that do not normally have high screening values. An example of this type of process unit is one that already has a leak detection and repair program in place to prevent the release of odor-causing chemicals. At this type of process unit, leaks may be quickly detected and repaired.

For the first alternative, a minimum of 24 bags are required, rather than 30, because sources with screening values greater than 100,000 ppmv do not need to be bagged. Thus, a minimum of six sources each should be chosen for bagging from each of the screening ranges presented above except for the greater than 100,000 ppmv range. In the event that a source screens at 100,000 ppmv or greater, emissions can be estimated using "pegged" emission rates shown in table 2-13 for SOCFI process units, and in table 2-14 for petroleum industry process units.

For the second alternative, a minimum of 18 bags are required, because sources screening greater than 10,000 ppmv do not need to be bagged. Thus, a minimum of six sources should be chosen for bagging from the 1 to 100 ppmv range, the 100 to 1000 ppmv range, and the 1,000 to 10,000 ppmv range. In the event that a source screens at 10,000 ppmv or greater, emissions can be estimated using the applicable greater than or equal to 10,000 ppmv pegged emission rate presented in table 2-13 for SOCOMI process units, or table 2-14 for petroleum industry process units. An advantage of using the greater than or equal to 10,000 ppmv pegged emission rates is that several of the available portable monitoring instruments have a maximum readout of 10,000 ppmv, and to obtain a screening value from a source screening at 10,000 ppmv, it is necessary to install a dilution probe. However, if the greater than or equal to 10,000 ppmv factor is used, installing a dilution probe is not necessary for this alternative.

The above groupings and recommended number of sources are given as guidelines. They are based on experience in measuring leak rates and developing leak rate/screening value correlations. Other source selection strategies can be used if an appropriate rationale is given.

With mass emissions data and screening values, leak rate/screening value correlations can be generated using the following methodology. Least-squares regression analyses are completed for each equipment type/service, regressing the log of the leak rate on the log of the screening concentration, according to:

$$\text{Log}_{10} (\text{leak rate [in kg/hr]}) = \beta_0 + \beta_1 \times \text{Log}_{10} (\text{SV})$$

where:

β_0, β_1 = Regression constants; and

SV = Screening value.

Note that the results are the same whether the base 10 or natural logarithm are used (see appendix B). The equations presented here are written assuming the base 10 logarithm is used. All analyses should be conducted using logarithms of both the leak rate and screening value because this type of data has been shown to be log-normally distributed. A scale bias correction factor (SBCF) is required in transforming the equation in the log-scale back to the original units. The transformed equation is the unit-specific correlation, and is expressed as:

$$\text{Leak rate} = \text{SBCF} \times 10^{\beta_0} \times \text{SV}^{\beta_1}$$

where:

- Leak rate = Emission rate of TOC's from the individual equipment piece (kg/hr);
- SBCF = Scale bias correction factor;
- β_0, β_1 = Regression constants; and
- SV = Screening value.

The SBCF is a function of the mean square error of the correlation in log space. The greater the range of possible emission rates for a given screening value, the greater the SBCF will be. The purpose of the SBCF is to reflect this range when transforming the correlation out of log space. When regressed in log space, in general, approximately half of the data points will lie above the correlation line and half will lie below it, and, for a given screening value, the correlation will pass through the mean log leak rate (i.e., the geometric mean). Thus, one way of thinking of the correlation in log space is that it predicts the geometric mean emissions rate across the range of screening values. However, the geometric mean always underestimates the arithmetic mean.

A simplified hypothetical example will help demonstrate this point: For a screening value of 500,000 ppmv, three bagging data points were obtained with mass emission rates of 0.1 kg/hr,

1 kg/hr, and 10 kg/hr. In log space, these emission rates correspond to $\log_{10} (0.1) = -1$, $\log_{10} (1) = 0$, and $\log_{10} (10) = 1$, respectively. Thus, the geometric mean of these three points is $(-1 + 0 + 1)/3 = 0$. Directly transforming this geometric mean to normal space predicts an emission rate for a screening value of 500,000 ppmv of $10^0 = 1$ kg/hr, whereas the arithmetic mean of the emission rates is $(0.1 + 1 + 10)/3 = 3.7$ kg/hr. From this example, it can be seen that the geometric mean underestimates the arithmetic mean.

Thus, if the correlation was directly transformed, it would underestimate the true average emission rate associated with a given screening value, and, for this reason, the SBCF is necessary to transform the correlation out of log space.

In appendix B, additional details on developing a process-unit specific correlation are presented. Appendix B also contains information on development of the revised SOCFI correlations.

2.4 SPECIAL TOPICS

There are several special topics relevant to estimating equipment leak emissions that are not specific to any one of the four approaches that have been described. These special topics are discussed in this section:

- Speciating emissions;
- Using response factors;
- Monitoring instrument type and calibration gas;
- Estimating emissions for equipment not screened (when other screening data are available);
- Using screening data collected at several different times;
- Estimating VOC emission rates from equipment containing organic compounds not classified as VOC's (such as methane and ethane); and
- Estimating equipment leak emissions of inorganic compounds.

Each of these topics above are addressed in the following sections.

2.4.1 Speciating Emissions

For each of the four approaches for estimating equipment leak emissions, the equations presented are used to estimate TOC emissions for estimating equipment leak emissions. Often, in a chemical-handling facility, material in equipment is a mixture of several chemicals, and, in some cases, it may be necessary to estimate emissions of a specific VOC in the mixture. The following equation is used to speciate emissions from a single equipment piece:

$$E_x = E_{\text{TOC}} \times (WP_x/WP_{\text{TOC}})$$

where:

- E_x = The mass emissions of organic chemical "x" from the equipment (kg/hr);
- E_{TOC} = The TOC mass emissions from the equipment (kg/hr) calculated from either the Average Emission Factor, Screening Ranges, Correlation, or Unit-Specific Correlation approaches;
- WP_x = The concentration of organic chemical "x" in the equipment in weight percent; and
- WP_{TOC} = The TOC concentration in the equipment in weight percent.

An assumption in the above equation is that the weight percent of the chemicals in the mixture contained in the equipment will equal the weight percent of the chemicals in the leaking material. In general, this assumption should be accurate for single-phase streams containing (1) any gas/vapor material, or (2) liquid mixtures containing constituents of similar volatilities.

If the material in the equipment piece is a liquid mixture of constituents with varying volatilities, in certain cases this assumption may not be correct. Whether or not the assumption is valid for a liquid mixture of varying volatilities depends on the physical mechanism of how the leakage occurs from the equipment.

If the physical mechanism is one in which the liquid "flashes" before it leaks from the equipment, the leaking vapor may contain a higher concentration of the more volatile constituents than is contained in the liquid mixture. On the other hand, if the mechanism is one in which the liquid material leaks from the equipment and then evaporates, the assumption that the weight percent of each constituent in the liquid will equal the weight percent of each constituent in the vapor is valid. There are no clear guidelines to determine what mechanism is taking place for any given piece of equipment; for this reason, unless there is information to suggest otherwise, it should be assumed that the leaking vapor has the same concentrations as the liquid.

For those cases where it is suspected the leaking vapor will have different concentrations than the liquid, engineering judgement should be used to estimate emissions of individual chemical species. An example might be equipment containing material in two phases. Another hypothetical example is a case where equipment contain a liquid mixture of two constituents with one of the constituents having a very low vapor pressure and the other a much higher vapor pressure. Leaks may occur from the equipment such that the constituent with higher vapor pressure volatilizes to the atmosphere, but the constituent with lower vapor pressure is washed to the waste water treatment system prior to volatilization.

2.4.2 Using Response Factors

A correction factor that can be applied to a screening value is a response factor (RF) that relates the actual concentration to the measured concentration of a given compound, using a specific reference gas. As stated earlier, screening values are obtained by using a portable monitoring instrument to detect VOC's at an equipment piece leak interface. An "ideal" screening RF value is one that is equal to the actual concentration of VOC's at the leak interface. However, portable monitoring instruments used to detect TOC concentration do not respond to different TOC's equally. (This is discussed in more detail in chapter 3.0). To demonstrate this point, consider a monitoring

instrument calibrated using a reference gas. If the instrument is calibrated correctly and is used to measure the concentration of the gas with which it has been calibrated, it will indicate the actual concentration. However, when used to measure other gases for which the monitoring instrument is more or less sensitive than the calibration gas, it will not indicate the actual concentration. To correct for this, RF's have been developed. The RF is calculated using the equation:

$$RF = AC/SV$$

where:

RF = Response factor;

AC = Actual concentration of the organic compound (ppmv);
and

SV = Screening value (ppmv).

The value of the RF is a function of several parameters. These parameters include the monitoring instrument, the calibration gas used to calibrate the instrument, the compound(s) being screened, and the screening value.

The correlations presented in this chapter have been developed primarily from screening value/mass emission data pairs collected from equipment containing compounds that had RF's less than three. Thus, for cases in which a calibrated instrument is used to measure concentrations of a compound for which that instrument has an RF of three or less, reasonably accurate emission estimates can be obtained directly without adjusting the screening value. However, for a case in which a compound has an RF greater than three for the calibrated instrument, the emissions estimated using the unadjusted screening value will generally underestimate the actual emissions. The EPA recommends that if a compound (or mixture) has an RF greater than three, then the RF should be used to adjust the screening value before it is used in estimating emissions.

A detailed listing of published RF's is contained in appendix D. These RF's were developed by injecting a known concentration of a pure compound into a monitoring instrument and comparing that actual concentration to the instrument readout (i.e., screening value).

As an example of applying a RF, consider chloroform. From table D-2 in appendix D, it can be seen that the RF for chloroform at an actual concentration of 10,000 ppmv is equal to 4.48 for a Foxboro OVA-108 monitoring instrument calibrated with methane. Thus, when the actual concentration of chloroform is 10,000 ppmv, the instrument will read 10,000 ppmv divided by 4.48, which equals 2,230 ppmv. If the measured value for chloroform was directly entered into the correlation, it would tend to underestimate emissions. (Note that when the RF is less than 1 the unadjusted screening value will tend to overestimate actual emissions.)

The RF's in appendix D are for pure compounds. Those RF's can be used to estimate the RF for a mixture using the equation:

$$RF_m = \frac{1}{\sum_{i=1}^n (x_i / RF_i)}$$

where:

- RF_m = Response factor of the mixture;
- n = Number of components in the mixture;
- x_i = Mole fraction of constituent i in the mixture; and
- RF_i = Response factor of constituent i in the mixture.

This equation is derived in appendix A.

An alternative approach for determining the RF of a pure compound or a mixture is to perform analysis in a laboratory to generate the data used to calculate a RF. The approach for generating these data in the laboratory is described in chapter 3.0. The approach involves injecting samples of a known concentration of the material of interest into the actual portable monitoring instrument used to obtain the screening values and calculating the RF based on the instrument readout.

In general, calculating the RF by performing analysis on site will give the most accurate RF information, since, among other factors, RF's have been shown to be a function of the individual monitoring instrument.

Ideally, when using screening values to estimate equipment leak emissions, the RF would be equal to 1, and, in this way, the screening value would be the actual concentration. However, because RF's are a function of several parameters, this cannot normally be achieved. Response factors can be used to correct all screening values, if so desired. To evaluate whether a RF correction to a screening value should be made, the following three steps can be carried out.

- (1) For the combination of monitoring instrument and calibration gas used, determine the RF's of a given material at an actual concentration of 500 ppmv and 10,000 ppmv. (See appendix D; in some cases, it may not be possible to achieve an actual concentration of 10,000 ppmv for a given material. In these cases, the RF at the highest concentration that can be safely achieved should be determined.)
- (2) If the RF's at both actual concentrations are below 3, it is not necessary to adjust the screening values.
- (3) If either of the RF's are greater than 3, then the EPA recommends an RF be applied for those screening values for which the RF exceeds 3.

One of the following two approaches can be applied to correct screening values:

- (1) Use the higher of either the 500 ppmv RF or the 10,000 ppmv RF to adjust all screening values.
- (2) Generate a response factor curve to adjust the screening values.

A RF curve can be generated in one of two ways. The simplest way is to assume that the RF value is a linear function of the screening value. The first step to generate a line relating screening value to RF is to convert the RF at the actual concentration to the RF at the associated screening value. This is done by dividing the RF by the actual concentration to get the associated screening value. Thus, if, at an actual concentration

of 10,000 ppmv, an instrument has a RF of 5, this corresponds to a screening value of 2,000 ppmv (i.e., 10,000 ppmv divided by 5). This procedure is implemented at both actual concentrations of 10,000 ppmv and 500 ppmv, and a line is drawn between the RF's at each associated screening value. This line can then be used to estimate the RF at any given screening value. (See appendix A for a demonstration of this procedure.) The line should not be extrapolated for screening values beyond the endpoints. For these screening values, the endpoint RF should be applied.

For some materials, the RF is nonlinear as the screening value increases. For these materials, RF's at several screening values can be estimated by collecting data in a laboratory, as mentioned earlier. The RF/screening value relationship can then be generated by fitting a curve through the data pairs.

When an RF is used, the screening value is multiplied by the RF before mass emissions are estimated. Thus, if a screening value is 3,000 ppmv and the associated RF is 4, then the screening value must be adjusted to 12,000 ppmv (i.e., 3,000 multiplied by 4) before mass emissions are predicted.

It should be noted that if it is possible to calibrate the monitoring instrument with the material contained in the equipment that is being screened, the RF should equal 1. Thus, theoretically, the screening values will equal the actual concentration, and no RF adjustment will be necessary. If it is necessary to apply RF's, site personnel should use engineering judgement to group process equipment into streams containing similar compounds. All components associated with a given stream can then be assigned the same RF, as opposed to calculating an RF for each individual equipment piece.

2.4.3 Monitoring Instrument Type and Calibration Gas

When the correlations presented in section 2.3 were developed, in general, for each of the source categories, the data were collected using a specific type of monitoring instrument calibrated with a specific calibration gas. The correlations are intended to relate actual concentration to mass emissions. For this reason, screening values obtained from any

combination of monitoring instrument and calibration gas can be entered directly into the correlations as long as the screening values are an indication of actual concentration. If the screening values are not an indication of the actual concentration, the guidelines set forth in the previous section on RF's can be applied to correct the screening values (i.e., screening values should be adjusted if the RF is greater than 3). Otherwise, it is not necessary to correct screening values to account for the instrument type and calibration gas that were used to develop the correlation curves developed by the EPA.

2.4.4 Estimating Emissions for Equipment Not Screened

Often, screening data cannot be collected for all of the equipment pieces in a process unit. In some cases, equipment are difficult or unsafe to screen. Difficult or unsafe to screen equipment must be included in the equipment counts. For these equipment pieces, the average emission factors must be used to estimate emissions.

In other cases, it is not possible to screen every equipment piece due to cost considerations. This is particularly true for connectors. Appendix E provides criteria for determining how many connectors must be screened to constitute a large enough sample size to identify the screening value distribution for connectors. If the criteria in appendix E are met, the average emission rate for connectors that were screened can be applied to connectors that were not screened. It should be noted that if connectors must be included in a leak detection and repair program as part of an equipment leaks standard, then all connectors must be screened. For equipment types other than connectors, if they are not monitored, the Average Emission Factor approach should be used to estimate emissions.

2.4.5 Using Screening Data Collected at Several Different Times

When screening data is collected and used to estimate emissions, the emissions estimate represents a "snapshot" of emissions at the time the screening data were obtained. Over

time, it is possible that more screening data will be collected, and that for individual equipment pieces, several screening values will have been obtained at different time periods. For example, if quarterly monitoring is performed on a valve, in an annual period four screening values will be obtained from the valve. The annual emissions from the valve should be calculated by determining the emissions for each quarter based on the operational hours for the quarter, and summing the quarterly emissions together to arrive at emissions for the entire year. See appendix A for an example of estimating emissions from an equipment piece for which more than one screening value has been obtained.

2.4.6 Estimating VOC Emission Rates from Equipment Containing Non-VOC's

Some organic compounds not classified as VOC's can be detected by the screening instrument. Because the compounds are detected, the emissions associated with the screening value will include emissions of the "non-VOC's." The two key organic compounds not classified as VOC's are methane and ethane, but other organic compounds not classified as VOC's include methylene chloride, 1,1,1-trichloroethane, and several chlorofluorocarbons. An approach very similar to that outlined in section 2.4.1 (Speciating Emissions) is used to estimate VOC emissions from equipment containing these non-VOC's mixed with VOC's.

Once TOC emissions have been estimated by using either the Average Emission Factor, the Screening Ranges, the Correlation, or the Unit-Specific Correlation approaches, the VOC emissions from a group of equipment containing similar composition can be calculated using the equation:

$$E_{VOC} = E_{TOC} \times (WP_{VOC}/WP_{TOC})$$

where:

E_{VOC} = The VOC mass emissions from the equipment (kg/hr);

E_{TOC} = The TOC mass emissions from the equipment (kg/hr) calculated from either the Average

Emission Factor, Screening Ranges, Correlation, or Unit-Specific Correlation approaches;

WP_{VOC} = The concentration of VOC in the equipment in weight percent;

WP_{TOC} = The TOC concentration in the equipment in weight percent.

2.4.7 Estimating Equipment Leak Emissions of Inorganic Compounds

The majority of data collected for estimating equipment leak emissions has been for TOC's or VOC's and not for inorganic compounds. Accordingly, the emission factors and correlations presented in section 2.3 are not intended to be applied for the used of estimating emissions of inorganic compounds. However, in some cases, there may be a need to estimate equipment leak emissions of inorganic compounds--particularly for those that exist as a gas/vapor or for those that are volatile. Some examples of inorganic compounds include sulfur dioxide, ammonia, and hydrochloric acid.

The best way to estimate equipment leak emissions of inorganic compounds would be to develop unit-specific correlations as described in section 2.3.4. To do this, it would be necessary to obtain a portable monitoring instrument that could detect the inorganic compounds. If it is not possible to develop a unit-specific correlation, but a portable monitoring instrument (or some other approach) can be used to indicate the actual concentration of the inorganic compound at the equipment leak interface, then the "screening values" obtained with this instrument can be entered into the applicable correlations presented in section 2.3.3 to estimate emissions. Alternatively, the equal to or greater than 10,000 ppmv, or the less than 10,000 ppmv emission factors could be applied. In the event that there is no approach that can be used to estimate the concentration of the inorganic compound at the leak interface, then in the absence of any other data, the average emission factors can be used.

2.5 REFERENCES

1. Radian Corporation. Assessment of Atmospheric Emissions from Petroleum Refining: Volume 4. Appendices C, D, E. Prepared for U.S. Environmental Protection Agency. Research Triangle Park, NC. Publication No. EPA-600/2-80-075d. July 1980.
2. Wetherhold, R.G., L.P. Provost, and C.D. Smith (Radian Corporation). Assessment of Atmospheric Emissions from Petroleum Refining: Volume 3. Appendix B. Prepared for U.S. Environmental Protection Agency. Research Triangle Park, NC. Publication No. EPA-600/2-80-075c. April 1980.
3. DuBose, D.A., J.I. Steinmetz, and G.E. Harris (Radian Corporation). Frequency of Leak Occurrence and Emission Factors for Natural Gas Liquid Plants. Final Report. Prepared for U.S. Environmental Protection Agency. Research Triangle Park, NC. EMB Report No. 80-FOL-1. July 1982.
4. 1993 Study of Refinery Fugitive Emissions from Equipment Leaks, Volumes I, II, and III, Radian DCN No. 93-209-081-02, Radian Corporation, Prepared for Western States Petroleum Association, Glendale, CA, and American Petroleum Institute, Washington, D.C., 1994.
5. Development of Fugitive Emission Factors and Emission Profiles for Petroleum Marketing Terminals, Volumes I and II, API 4588, Radian Corporation, Prepared for American Petroleum Institute, 1993.
6. Fugitive Hydrocarbon Emissions from Oil and Gas Production Operations, API 4589, Star Environmental, Prepared for American Petroleum Institute, 1993.
7. Emission Factors for Oil and Gas Production Operations, API 4615, Star Environmental, Prepared for American Petroleum Institute, 1995.
8. Letter from Robert Strieter, API, to David Markwordt, U.S. EPA, regarding the submittal of gasoline distribution facility fugitive equipment screening data. April 26, 1994.
9. Blacksmith, J.R., et al. (Radian Corporation.) Problem-Oriented Report: Frequency of Leak Occurrence for Fittings in Synthetic Organic Chemical Plant Process Units. Prepared for U.S. Environmental Protection Agency. Research Triangle Park, NC. Publication No. EPA-600/2-81-003. September 1980.
10. Langley, G.J. and R.G. Wetherhold. (Radian Corporation.) Evaluation of Maintenance for Fugitive VOC Emissions Control.

Prepared for U.S. Environmental Protection Agency. Research Triangle Park, NC. Publication No. EPA-600/S2-81-080. May 1981.

11. U.S. Environmental Protection Agency. Fugitive Emission Sources of Organic Compounds - Additional Information of Emissions, Emission Reductions, and Costs (section 2). Research Triangle Park, NC. Publication No. EPA-450/3 82-010. April 1982.

3.0 SOURCE SCREENING

3.1 INTRODUCTION

This chapter presents procedures for screening equipment components with a portable volatile organic compound (VOC) analyzer. When performing source screening, the portable analyzer probe opening is placed at the leak interface of the equipment component to obtain a "screening" value. The screening value is an indication of the concentration level of any leaking material at the leak interface. A screening value is not a direct measure of mass emissions rate, but, as discussed in chapter 2.0, can be entered into a mass emissions/screening value correlation equation to estimate mass emissions.

This chapter is divided into two sections. The first section provides a description of the portable analyzers that can be used when conducting screening surveys. Operating principles of the analyzers and performance criteria and specifications in the EPA Reference Method 21 (the method describing the use of portable VOC analyzers)¹ are described, and the use of monitoring devices that do not meet the EPA Reference Method 21 requirements is discussed. The second section presents the protocol for successfully conducting a screening program. This section includes methods to identify components to be included in the screening program, a discussion on the development of a systematic approach for performing the screening survey, the protocol for screening each of the equipment types, and recommendations for collecting and handling data.

3.2 MONITORING INSTRUMENTS

A number of portable VOC detection devices have the potential to measure the concentration level at the leak interface of equipment. Any analyzer can be used, provided it meets the specifications and performance criteria set forth in the EPA Reference Method 21, section 3.0.¹. Reference Method 21 is included in this document as appendix F.

In general, portable VOC monitoring instruments are equipped with a probe that is placed at the leak interface of a piece of equipment. A pump within the instrument draws a continuous sample of gas from the leak interface area to the instrument detector. The instrument response is a screening value--that is, a relative measure of concentration level. The screening value is in units of parts per million by volume (ppmv). However, the screening value does not necessarily indicate the actual total concentration at the leak interface of the compound(s) being detected because the sensitivity of instruments vary for different compounds. As discussed in section 2.4.2, response factors (RF's) relate actual concentration of a compound to the observed concentration from the detector. Before a monitoring instrument is used, it must first be calibrated using a reference gas containing a known compound at a known concentration. Methane and isobutylene are frequently used reference compounds.

3.2.1 Operating Principles and Limitations of Portable VOC Detection Devices

Monitoring instruments operate on a variety of detection principles, with the three most common being ionization, infrared absorption, and combustion. Ionization detectors operate by ionizing the sample and then measuring the charge (i.e., number of ions) produced. Two methods of ionization currently used are flame ionization and photoionization. Each of these detector types are briefly described below.

A standard flame ionization detector (FID) theoretically measures the total carbon content of the organic vapor sampled, but many other factors influence the FID readout. Although carbon monoxide and carbon dioxide (CO₂) do not produce

interferences, FID's react to water vapor at a low sensitivity. Furthermore, erratic readings may result if water condenses in the sample tube. A filter is used to remove particulate matter from the sample. Certain portable FID instruments are equipped with gas chromatograph (GC) options making them capable of measuring total gaseous non-methane organics or individual organic components. Certain organic compounds containing nitrogen, oxygen, or halogen atoms give a reduced response when sampled with an FID, and the FID may not respond to some organic compounds.

Photoionization detectors use ultraviolet light (instead of a flame) to ionize organic vapors. As with FID's, the detector response varies with the functional group in the organic compounds. Photoionization detectors have been used to detect equipment leaks in process units in the SOCOMI, especially for certain compounds, such as formaldehyde, aldehydes, and other oxygenated compounds, which will not give a satisfactory response on a FID or combustion-type detector.

Nondispersive infrared (NDIR) instruments operate on the principle of light absorption characteristics of certain gases. These instruments are usually subject to interference because other gases, such as water vapor and CO₂, may also absorb light at the same wavelength as the compound of interest. These detectors are generally used only for the detection and measurement of single components. For this type of detection, the wavelength at which a certain compound absorbs infrared radiation is predetermined and the device is preset for that specific wavelength through the use of optical filters. For example, if set to a wavelength of 3.4 micrometers, infrared devices can detect and measure petroleum fractions, including gasoline and naphtha.

Combustion analyzers are designed either to measure the thermal conductivity of a gas or to measure the heat produced by combustion of the gas. The most common method in which portable VOC detection devices are used involves the measurement of the heat of combustion. These detection devices are referred to as

hot wire detectors or catalytic oxidizers. Combustion analyzers, like most other detectors, are nonspecific for gas mixtures. In addition, combustion analyzers exhibit reduced response (and, in some cases, no response) to gases that are not readily combusted, such as formaldehyde and carbon tetrachloride.

3.2.2 Specifications and Performance Criteria of Portable VOC Detection Devices

As previously stated, any portable analyzer may be used as a screening device, provided it meets the specifications and the performance criteria called for in the EPA Reference Method 21. (See appendix F.) Reference Method 21 specifies the requirements that must be met when a facility is collecting screening data to comply with a regulation. The requirements of the EPA Reference Method 21 are also applicable when screening data are collected for the sole purpose of estimating emissions. When the requirements of Reference Method 21 refer to a "leak definition," this is the screening value indicating that a piece of equipment is leaking as defined in the applicable regulation. If screening data are collected for the sole purpose of estimating emissions, the equivalent to the "leak definition" concentration in the text that follows is the highest screening value (i.e., 10,000 ppmv) that the monitoring instrument can readout.

Reference Method 21 requires that the analyzer meet the following specifications:¹

- The VOC detector should respond to those organic compounds being processed (determined by the RF);
- Both the linear response range and the measurable range of the instrument for the VOC to be measured and the calibration gas must encompass the leak definition concentration specified in the regulation;
- The scale of the analyzer meter must be readable to ± 2.5 percent of the specified leak definition concentration;
- The analyzer must be equipped with an electrically driven pump so that a continuous sample is provided at a nominal flow rate of between 0.1 and 3.0 liters per minute;

- The analyzer must be intrinsically safe for operation in explosive atmospheres; and
- The analyzer must be equipped with a probe or probe extension for sampling not to exceed .25 inch in outside diameter, with a single end opening for admission of sample.

Note that the suction flow rate span allowed by Reference Method 21 is intended to accommodate a wide variety of instruments, and manufacturers guidelines for appropriate suction flow rate should be followed.

In addition to the above specifications, criteria for the calibration gases to be used are specified. A minimum of two calibration gases are required for analyzer performance evaluation. One is a "zero" gas, which is defined as air with less than 10 ppmv VOC; the other calibration gas, or reference gas, uses a specified reference compound in an air mixture. The concentration of the reference compound must approximately equal the leak definition specified in the regulation. If cylinder calibration gas mixtures are used, they must be analyzed and certified by the manufacturer to be within ± 2 percent accuracy. The shelf life must also be specified. Calibration gases can also be prepared by the user as long as they are accurate to within ± 2 percent.

The instrument performance criteria that each analyzer must meet are presented in table 3-1 and discussed in greater detail in the following sections.

3.2.2.1 Response Factor. The sensitivity of an analyzer varies, depending on the composition of the sample and concentration of VOC detected. The RF quantifies the sensitivity of the analyzer to each compound. The RF is defined by:

$$RF = \frac{\text{Actual Concentration of Compound}}{\text{Observed Concentration from Detector}}$$

An RF must be determined for each compound that is to be measured. Response factors may be determined either by testing or from referenced sources. (The RF's for many commonly screened compounds are presented in appendix D.) The RF tests are

TABLE 3-1. PERFORMANCE CRITERIA FOR PORTABLE VOC DETECTORS^a

Criteria	Requirement	Time interval
Instrument response factor	Must be <10 unless correction curve is used	One time, before detector is put in service.
Instrument response time	Must be ≤30 seconds	One time, before detector is put in service. If modification to sample pumping or flow configuration is made, a new test is required.
Calibration precision	Must be ≤10 percent of calibration gas value	Before detector is put in service and at 3-month intervals or next use, whichever is later.

^aSource: Reference 1.

required before placing the analyzer into service, but do not need to be repeated. The RF for each compound to be measured must be less than 10 for an analyzer to be acceptable for use in a screening program. According to Reference Method 21, the RF can either be measured in the laboratory using a prepared gas concentration at 80 percent of the applicable leak definition, or it can be taken from values published in the literature. When no instrument is available that meets this criteria when calibrated with the reference compound specified in the applicable regulation, the available instrument may be calibrated with one of the VOC's to be measured. However, the analyzer RF must still be less than 10 for each VOC to be measured.

As discussed in section 2.4.2, RF's depend on several parameters, including the compound, the screening value, the monitoring instrument, and the calibration gas. In chapter 2.0, guidance was provided on when and how to apply RF's for estimating emissions. Methods were presented on calculating an RF for a given chemical at a screening value other than one for which data were published. Methods were also presented for calculating RF's for mixtures.

In this chapter, several additional issues pertaining to RF's are discussed. These issues are (1) the consideration of RF's when selecting a monitoring instrument, (2) how laboratory analysis can be performed to generate data to determine an RF for a given compound, and (3) when laboratory analysis is recommended.

Response factors contained in appendix D can be used as a guide for selecting an appropriate monitoring device. If at the applicable leak definition, the RF of an instrument is greater than 10, that instrument does not meet Reference Method 21 requirements unless a substitute reference gas is used to calibrate the instrument. For example, at a concentration of 10,000 ppmv, it can be seen that when screening equipment in a process unit that contains cumene, an FID can be used (RF = 1.92 at an actual concentration of 10,000 ppmv), while the catalytic oxidation detector cannot (RF = 12.49). Similarly, at a

concentration of 10,000 ppmv, neither of these devices respond to carbon tetrachloride and, therefore, cannot be used unless calibrated with a substitute VOC such that an RF of under 10 can be calculated for this compound.

Response factors can be determined by laboratory analysis using the following method. First, the analyzer is calibrated using the reference gas. Then, for each organic species that is to be measured, a known standard in air is obtained or prepared. The concentration of the organic species should be at approximately the leak definition value. This mixture is then injected into the analyzer and the observed meter reading is recorded. The analyzer is then "zeroed" by injecting zero air until a stable reading is obtained. The procedure is repeated by alternating between the mixture and zero air until a total of three measurements are obtained. An RF is calculated for each repetition and then averaged over the three measurements. This procedure can be repeated at several different concentration values. The data can then be used to generate a curve that relates RF to screening value. (See appendix A.)

The most accurate method for estimating RF's is to perform laboratory analysis. This is particularly true because RF's vary, not just for the detector type, but also for each individual instrument. However, in some cases, time and resource constraints may require the use of published RF data. Nevertheless, a limitation of the published data is that it is typically specific to a pure compound for a single actual concentration value, detector type, and calibration gas. Additionally, although an RF for mixtures can be calculated as described in section 2.4.2 (i.e., if an RF is known for each individual compound), the most accurate RF for a mixture is calculated by preparing known standards of air for the mixture and injecting the standard into the analyzer as described earlier.

3.2.2.2 Response Time. The response time of an analyzer is defined as the time interval from a step change in VOC concentration at the input of a sampling system, to the time at which the corresponding concentration value is reached as displayed on the analyzer readout meter. Response time is determined by introducing zero air into the instrument sample probe. When the meter reading has stabilized, the specified calibration gas is injected. The response time is measured as the time lapsed between switching to the calibration gas and the time when 90 percent of the final stable reading is obtained. This test is performed three times and the response time is calculated as the average of the three tests. The response time must be equal to or less than 30 seconds for the analyzer to be acceptable for screening purposes.

The response time test is required before placing an analyzer in service. The response time must be determined for the analyzer configuration that will be used during testing. If a modification to the sample pumping system or flow configuration is made that would change the response time (e.g., change in analyzer probe or probe filter, or the instrument pump), a new test is required before the screening survey is conducted.

3.2.2.3 Calibration Precision. Calibration precision is the degree of agreement between measurements of the same known value. To ensure that the readings obtained are repeatable, a calibration precision test must be completed before placing the analyzer in service, and at 3-month intervals, or at the next use, whichever is later. The calibration precision must be equal to or less than 10 percent of the calibration gas value.

To perform the calibration precision test, three measurements are required for each non-zero concentration. Measurements are made by first introducing zero gas and adjusting the analyzer to zero. The specified calibration gas (reference) is then introduced and the meter reading is recorded. This procedure must be performed three times. The average algebraic difference between the meter readings and the known value of the calibration gas is then computed. This average difference is then divided by

the known calibration value and multiplied by 100 to express the resulting calibration precision as percent. The calibration precision of the analyzer must be equal to or less than 10 percent of the calibration gas value.

3.2.2.4 Safety. Portable instruments to detect VOC emissions from equipment leak sources are required to be used in potentially hazardous locations such as petroleum refineries and bulk gasoline terminals. The National Electrical Code requires that instruments to be used in hazardous locations be certified to be explosion-proof, intrinsically safe, or purged.

Hazardous locations are divided into three classes: Class I, Class II, and Class III. Each class is divided into two divisions (division 1 or 2) according to the probability that a hazardous atmosphere will be present and also into seven groups, depending on the type of hazardous material exposure: Groups A through D are flammable gases or vapors, and groups E, F, and G apply to combustible or conductive gases. Class I, division 1, groups A, B, C, and D locations are those in which hazardous concentrations of flammable gases or vapors may exist under normal operating conditions. Class I, division 2, groups A, B, C, and D locations are those in which hazardous concentrations of flammable gases may exist only under unlikely conditions of operation.

Any instrument considered for use in potentially hazardous environments must be classified as intrinsically safe for Class I, division 1 and class II, division 1 conditions at a minimum. The instrument must not be operated with any safety device, such as an exhaust flame arrestor, removed.

Table 3-2 lists several portable VOC detection instruments. table 3-2 includes manufacturer, model number, pollutants detected, principle of operation, and range. Note that additional instruments, not listed here, may be available.

3.2.3 Use of Monitoring Devices That Do Not Meet EPA Reference Method 21 Requirements

In some cases, a monitoring device may not be available that meets all of the performance specifications of the EPA Reference

TABLE 3-2. PORTABLE VOC DETECTION INSTRUMENTS

Manufacturer	Model no.	Pollutant(s) detected	Principle of operation	Range (ppm)
Bacharach Instrument Co., Santa Clara, California	L	Combustible gases	Catalytic combustion	0-100% LEL ^a
Foxboro, S. Norwalk, Connecticut	TLV Sniffer	Combustible gases	Catalytic combustion	0-1,000 and 0-10,000
	OVA-128	Most organic compounds	FID/GC	0-1,000
	OVA-108	Most organic compounds	FID/GC	0-10,000
Health Consultants	Miran IBX	Compounds that absorb infrared radiation	NDIR	Compound specific
	Detecto - PAK III	Most organic compounds	FID/GC	0-10,000
HNU Systems, Inc. Newton Upper Falls, Massachusetts	HW-101	Chlorinated hydrocarbons, aromatics, aldehydes, ketones, any substance that UV light ionizes	Photoionization	0-20, 0-200, 0-2,000
Mine Safety Appliances Co., Pittsburgh, Pennsylvania	40	Combustible gases	Catalytic combustion	0-10% and 0-100% LEL ^a
Survey and Analysis, Inc., Northboro, Massachusetts	On Mark Model 5	Combustible gases	Thermal conductivity	0-5 and 0-100% LEL ^a

^aLEL = Lower explosive limit.

Method 21. For example, there are several cases (e.g., phosgene) where the RF at 10,000 ppmv is greater than 10. An instrument may meet all other requirements, but fail as a Reference Method 21 instrument because it cannot meet the RF requirement. If an instrument fails to meet Reference Method 21 requirements, it can still be used for the purpose of estimating emissions if its reliability can be documented.

Two primary steps must be taken to document the reliability of an analyzer that fails to meet the Reference Method 21 requirements. First, a laboratory program must be undertaken to demonstrate the response of the monitoring instrument to the compounds being measured; that is, an instrument response curve must be developed for the entire screening value range and documented so that screening values taken in the field can be adjusted to actual concentrations if necessary. Second, the testing program must be sufficiently well-documented to demonstrate how the instrument will be used when screening equipment. For example, if the response time of the candidate instrument exceeds the Reference Method 21 performance specification, the test plan should reflect added screening time at each potential leak point. Once this laboratory demonstration has been completed and the screening value correction curve has been established, the instrument may be used in a screening program.

3.3 THE SCREENING PROGRAM

The goal of the screening program is to measure VOC concentrations at seals, shafts, and other potential leak points. All equipment to be included in the screening survey needs to be identified before the screening program starts. A list of equipment types that are potential sources of fugitive emissions is provided in table 3-3.

3.3.1 Identification of Equipment to be Screened

The first step in the screening survey is to precisely define the process unit boundaries. This is usually straightforward, but occasionally multiple units may be built on the same pad and share some common facilities. A process unit can be defined as

TABLE 3-3. EQUIPMENT LEAK EMISSION SOURCES

<u>Equipment types</u>
Agitator seals
Compressor seals
Connectors
Diaphragms
Drains
Dump lever arms
Flanges
Hatches
Instruments
Loading arms
Meters
Open-ended lines
Polished rods
Pressure relief devices
Pump seals
Stuffing boxes
Valves
Vents
<u>Service</u>
Gas/vapor
Light liquid
Heavy liquid

the smallest set of process equipment that can operate independently and includes all operations necessary to achieve its process objective. The exact basis for the unit definition should be documented. A plot plan of the unit should be obtained and marked with the appropriate boundaries.

The next step is to obtain a simplified flow diagram of the process and note the process streams. The actual screening and data collection can be done efficiently by systematically following each stream. For example, a logical starting point would be where one of the feed lines enters the process boundary. The screening team would follow that line, screening all sources, until the line terminates at the connectors of a reactor or separation step. This approach offers the advantage of screening groups of equipment with roughly the same composition of material in the line. Screening would then continue on the outlet side of the reactor or separation equipment. Minor loops, such as a bypass around a control valve, pump, or heat exchanger, should be screened on the initial pass. Larger loops of process equipment, such as parallel passes and processing alternatives, are more effectively treated as separate streams.

Each source should be uniquely identified to indicate that it has been screened. For example, sources can be tagged. Tags can consist of any form of weatherproof and readily visible identification. Alternatively, a process unit can be considered appropriately tagged if the unit has a system of identifying markings with an associated diagram allowing easy location of marked sources. Once all the equipment along the major streams has been screened, the unit should be divided into a grid to search for fittings missed on the initial survey. Consistent with equipment leaks standards, equipment that is unsafe to monitor or very difficult to access does not need to be included in the survey. Documentation must be provided, however, to substantiate the unsafe or confined nature of such equipment.

3.3.2 Procedure for Screening

Once the equipment to be screened has been identified, the procedures outlined in the EPA Reference Method 21 to screen each equipment type are followed.¹ The probe inlet is placed at the surface of the potential leak interface where leakage could occur. (The potential leak interface is the boundary between the process fluid and the atmosphere.) For equipment with no moving parts at the leak interface, the probe should be placed directly on the leak interface; for equipment with moving parts (e.g., pumps, compressors, and agitators), the probe should be placed approximately 1 centimeter off from the leak interface. Care must be taken to ensure that the probe is held perpendicular, not tangential, to the leak potential interface; otherwise, inaccurate readings will result. The probe must then be moved along the interface periphery while observing the instrument readout. If an increased meter reading is observed, slowly move the probe along the interface where concentrations register until the maximum meter reading is obtained. The probe inlet should be left at this maximum reading location for approximately two times the instrument response time. The maximum reading is recorded as the screening value.

The instrument measurement may exceed the scale of the instrument. This is referred to as a "pegged" readout. For example, for several instruments, the highest readout on the scale is 10,000 ppmv. For the purposes of generating an emissions estimate, a dilution probe should be employed to measure concentrations greater than the instrument's normal range unless average emission factors for greater than or equal to the "pegged" readout are applied. It is important to note that extending the measurement range necessitates the calibration of the instrument to the higher concentrations.

Care should be taken to avoid fouling the probe with grease, dust, or liquids. A short piece of Teflon® tubing can be used as a probe tip extender and then can be snipped off as the tip fouls. In areas with a noticeable particulate loading, this tubing can be packed loosely with untreated fiberglass, which

acts as a filter. (Note that the instrument must also be calibrated with this filter in place.) If a surface to be screened is obviously dirty, hold the probe tip just over the surface to avoid scooping up contaminants. Some fouling is unavoidable, so it is recommended that the probe tip filter be cleaned at least daily and any other filters on a weekly basis. Normally, these filters can be cleaned by just tapping them lightly on a table top, but if the deposits are wet and caked on, they should be washed with an aqueous solution of soap and alcohol. This solution also can be used to wash the probe and transfer line periodically. Care should be taken to blow the equipment dry before reuse.

This general procedure can be used to screen equipment such as valves, connectors and flanges, pumps and compressors, open-ended lines, and other potential sources of VOC leakage, such as pressure relief devices, loading arms, stuffing boxes, instruments, vents, dump lever arms, drains, diaphragms, hatches, notes, or polished rods. The following sections describe the location on each type of equipment where screening efforts should be concentrated.

3.3.2.1 Valves. For valves, the most common source of leaks is at the seal between the stem and housing. To screen this source, the probe opening is placed where the stem exits the packing gland and is moved around the stem circumference. The maximum reading is recorded as the screening valve. Also, the probe opening is placed at the packing gland take-up connector seat, and the probe is moved along the periphery. In addition, valve housings of multipart assemblies should be screened at the surface of all points where leaks could occur. Figures 3-1 through 3-5 illustrate screening points for several different types of valves.

3.3.2.2 Connectors and Flanges. For connectors, the probe opening is placed at the outer edge of the connector - gasket interface and the circumference of the connector is sampled. For screwed connectors, the threaded connection interface must also be screened. Other types of nonpermanent joints, such as

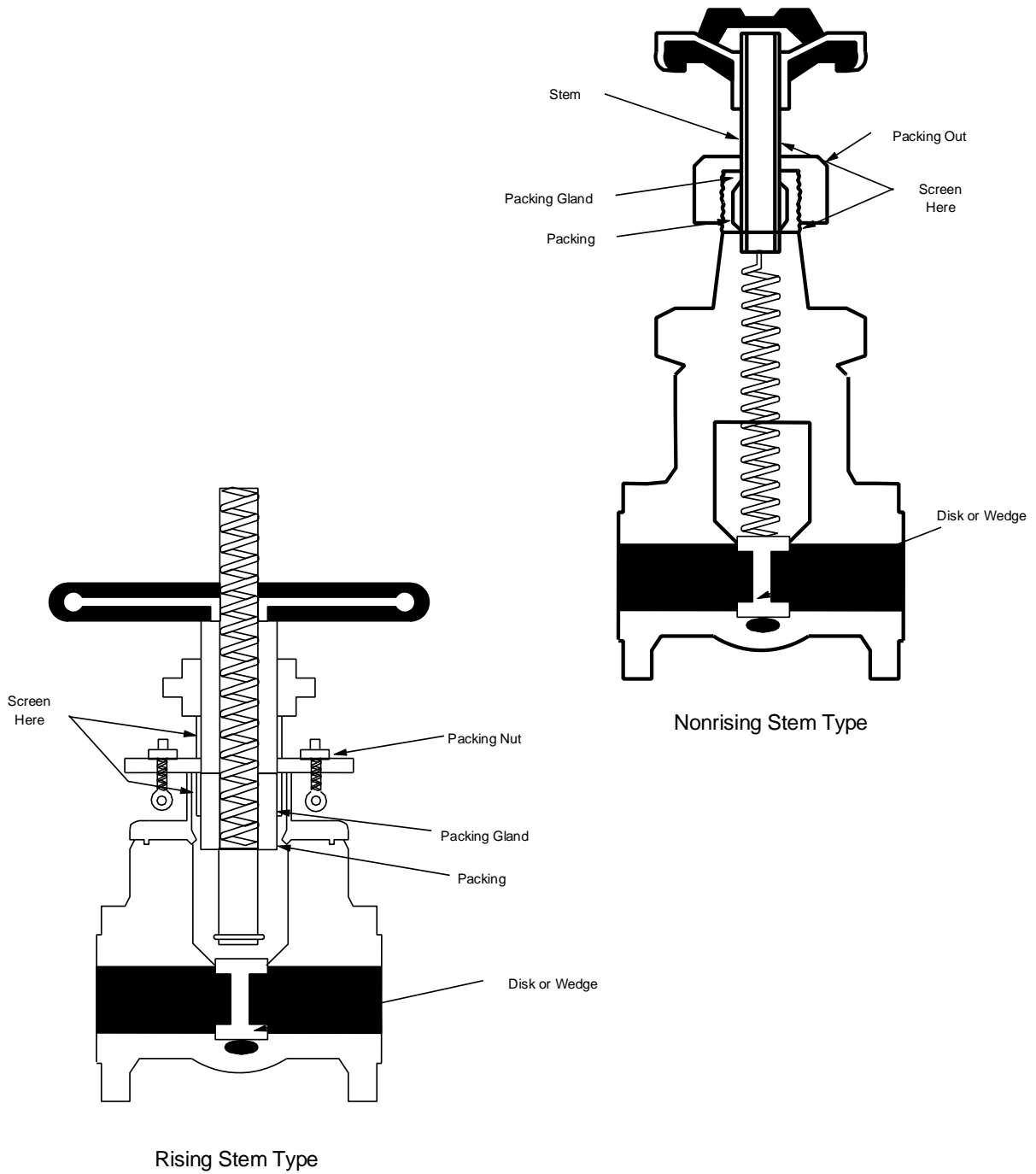
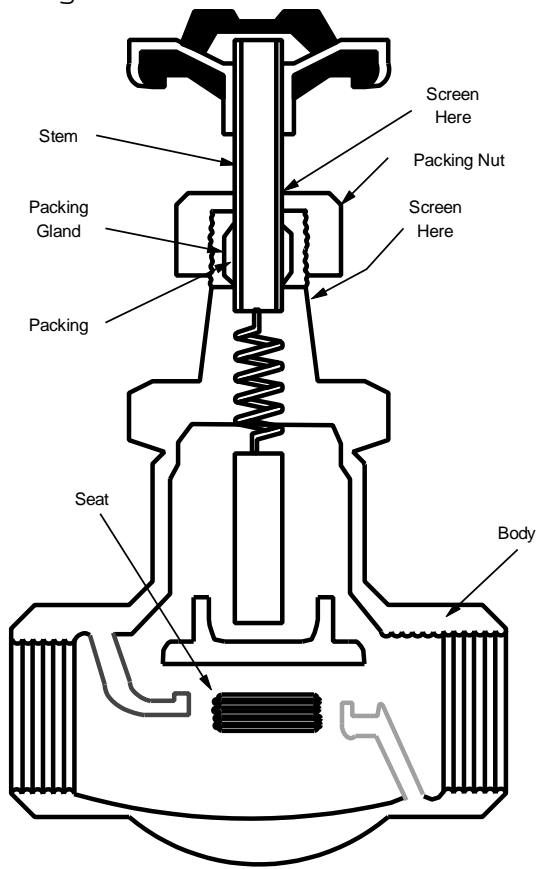
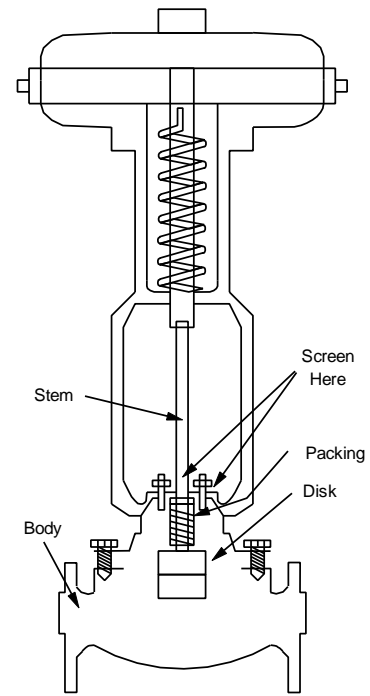

Figure 3-1. Gate Valves

through



Manual Globe Valve



Globe Type Control Valve

Figure 3-2. Globe Valves

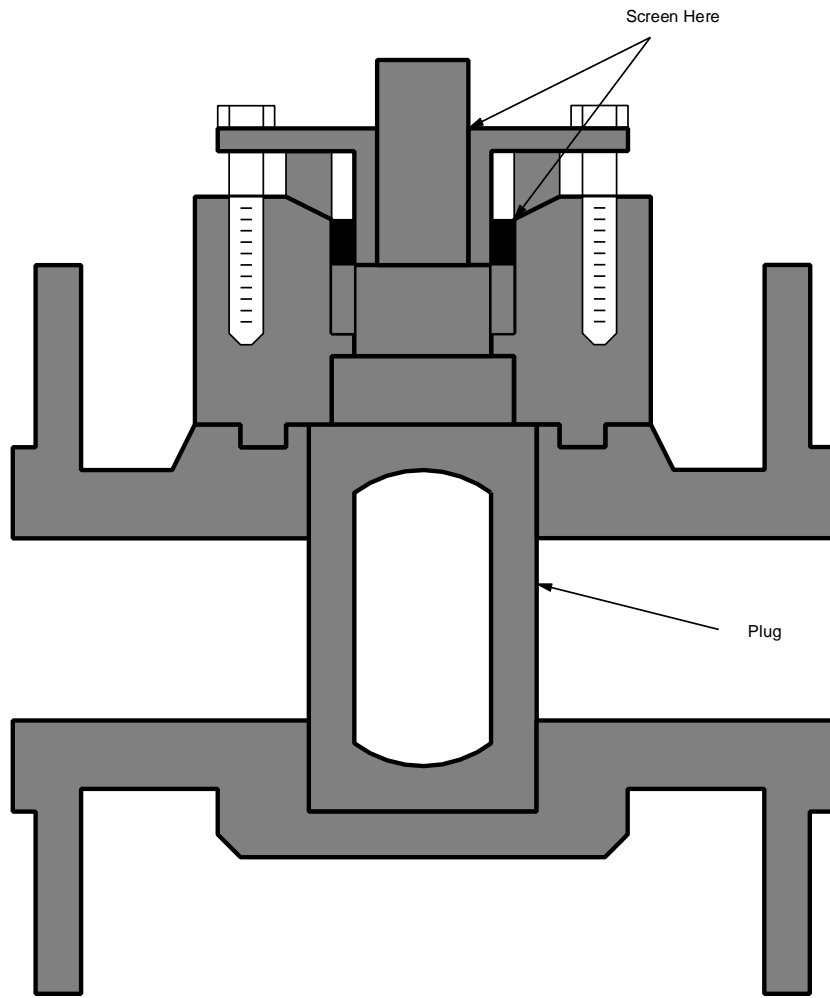
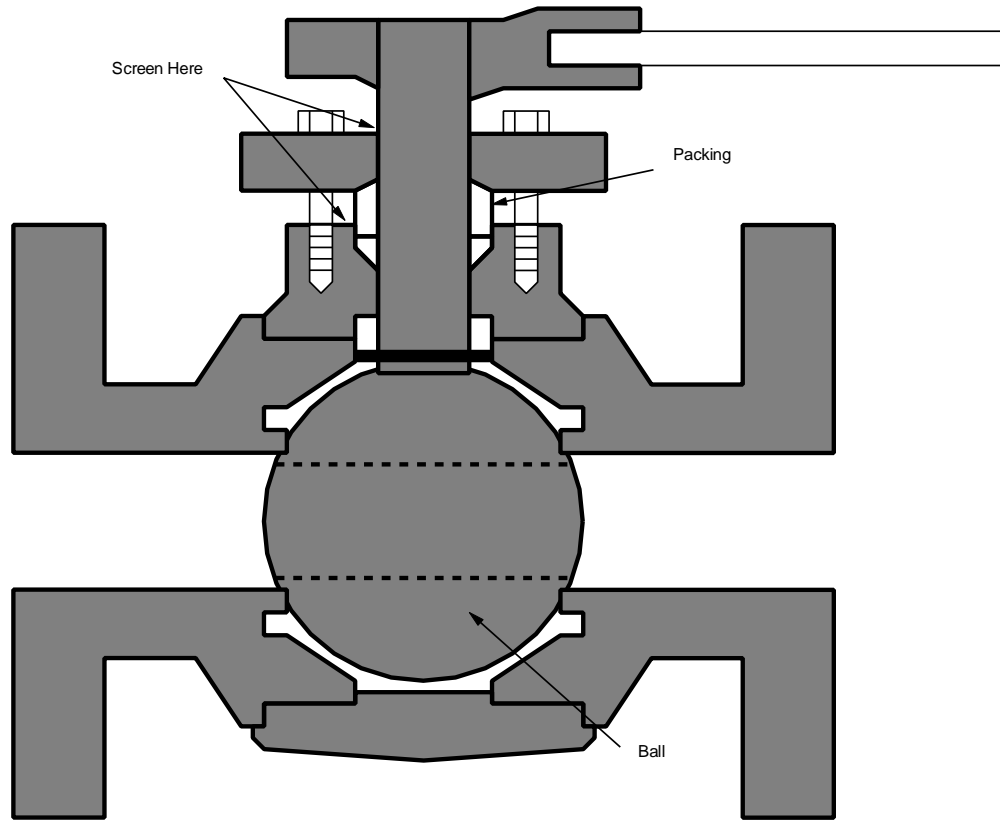
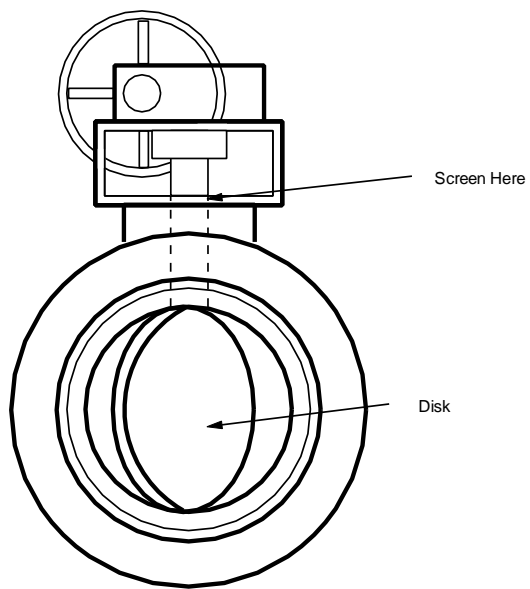

Figure 3-3. Lubricated Plug Valve



Ball Valve



Butterfly Valve

Figure 3-4. Ball Valve and Butterfly Valve

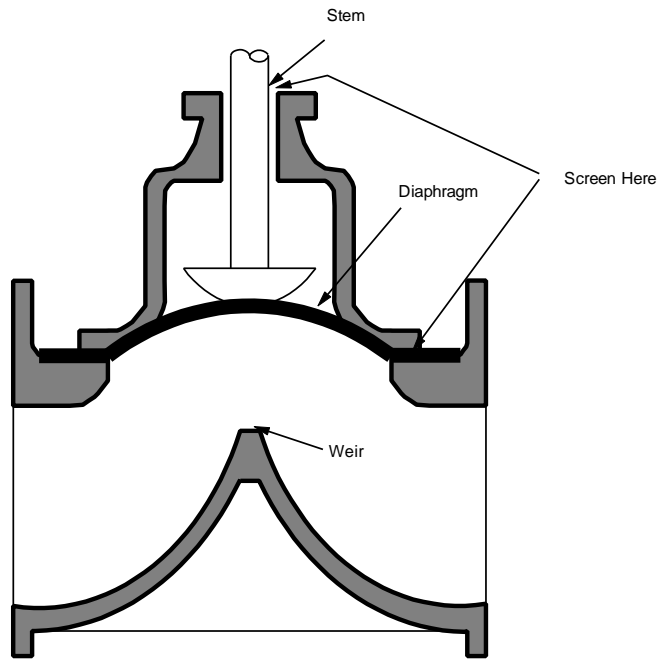

Weir-Type Diaphragm Valve

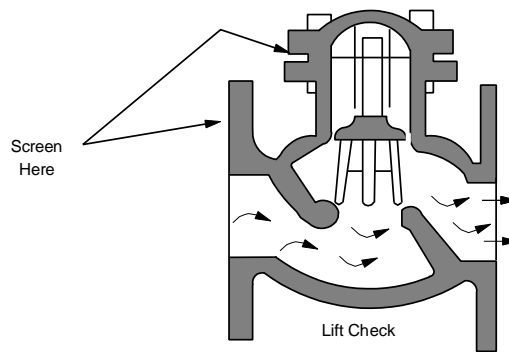
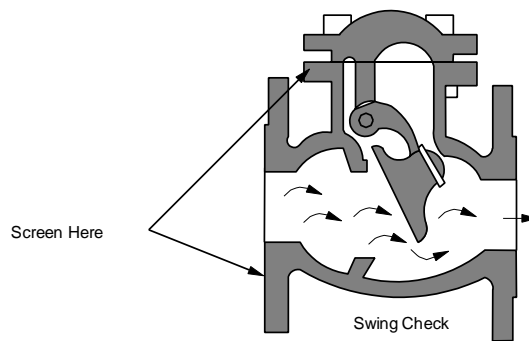

Check Valves

Figure 3-5. Weir-Type Diaphragm Valve and Check Valves

threaded connections, are sampled with a similar traverse.

3.3.2.3 Pumps, Compressors, and Agitators. Pumps, compressors, and agitators are screened with a circumferential traverse at the outer surface shaft and seal interface where the shaft exits the housing. If the source is a rotating shaft, the probe inlet is positioned within 1 centimeter of the shaft - seal interface. If the housing configuration prevents a complete traverse of the shaft periphery, all accessible portions must be sampled. All other joints on the pump or compressor housing where leakage could occur should also be sampled. Figure 3-6 illustrates screening points for two types of centrifugal pumps.

3.3.2.4 Pressure Relief Devices. The configuration of most pressure relief devices prevents sampling at the sealing seat. Because of their design and function, pressure relief devices must be approached with extreme caution. These devices should not be approached during periods of process upsets, or other times when the device is likely to activate. Similarly, care must be used in screening pressure relief devices to avoid interfering with the working parts of the device (e.g., the seal disk, the spring, etc.) For those devices equipped with an enclosed extension, or horn, the probe inlet is placed at approximately the center of the exhaust area to the atmosphere. It should be noted that personnel conducting the screening should be careful not to place hands, arms, or any parts of the body in the horn. Figure 3-7 illustrates the screening points for a spring-loaded relief valve.

3.3.2.5 Open-Ended Lines. Fugitive leaks from open-ended lines are emitted through a regularly shaped opening. If that opening is very small (as in sampling lines of less than 1 inch in diameter), a single reading in the center is sufficient. For larger openings it is necessary to traverse the perimeter of the opening. The concentration at the center must also be read.

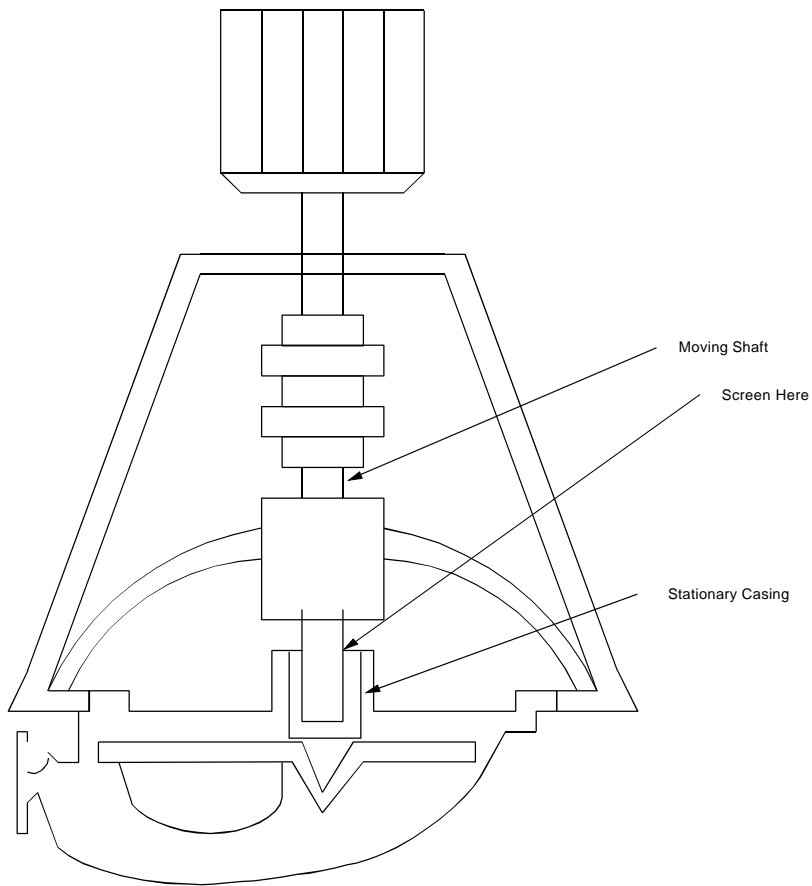

Vertical Centrifugal Pump

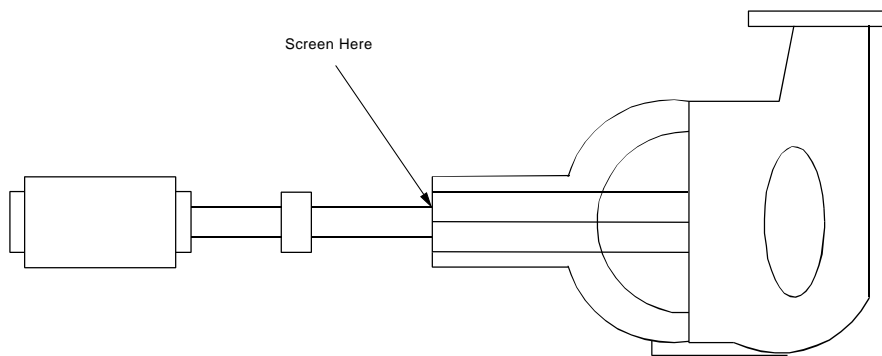

Horizontal Centrifugal Pump

Figure 3-6. Centrifugal Pumps

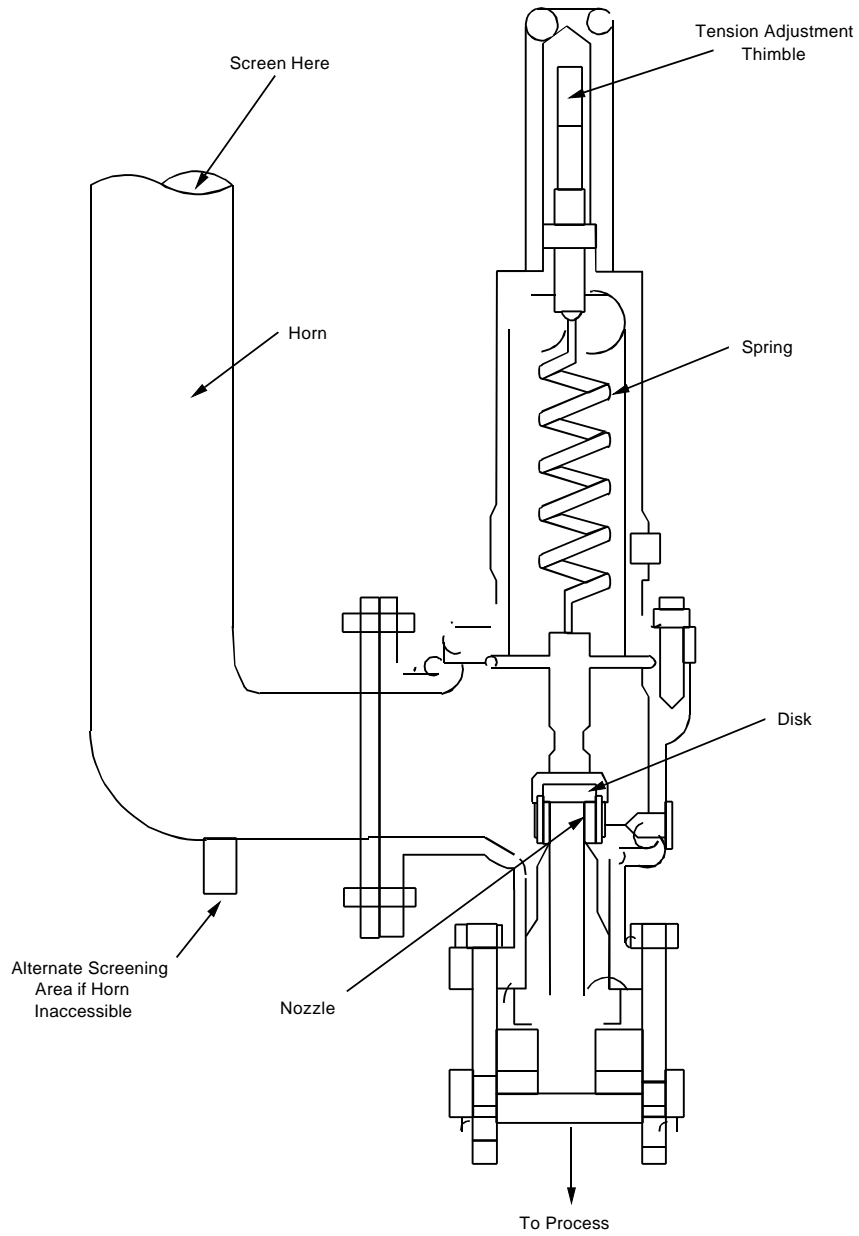

Figure 3-7. Spring-Loaded Relief Valve

3.3.3 Data Handling

To ensure that data quality is maintained, it is recommended that data be recorded on prepared data sheets. The data collected should include the following:

1. Monitoring instrument type and model number.
2. Operator's name.
3. Date.
4. Component identification number (ID number). (If permanent ID's are not in place, assign ID's as each source is screened.)
5. Component type (i.e., valve, connector, open-ended line, etc.)
6. Location/stream. (Provide brief description of where the screened component is located and the composition of material in the equipment.)
7. Service (i.e., gas, light liquid, or heavy liquid).
8. Number of hours per year the component is in service.
9. Screening value (ppmv).
10. Background concentration (ppmv).
11. Comments. If any explanation is required, it should be noted in a "comments" section.

In some cases, it may be necessary or desirable to adjust the screening values for RF. In these cases, the data sheet should be designed to accommodate extra columns for RF and corrected screening values. Table 3-4 provides an example data sheet that may be used to log measurements taken during a screening program.

3.4 REFERENCES

1. Code of Federal Regulations, Title 40, Part 60, Appendix A. Reference Method 21, Determination of Volatile Organic Compound Leaks. Washington, DC. U.S. Government Printing Office. Revised June 22, 1990.

4.0 MASS EMISSION SAMPLING

4.1 INTRODUCTION

This chapter describes the procedures for "bagging" equipment to measure mass emissions of organic compounds. An equipment component is bagged by enclosing the component to collect leaking vapors. Measured emission rates from bagged equipment coupled with screening values can be used to develop unit-specific screening value/mass emission rate correlation equations. Unit-specific correlations can provide precise estimates of mass emissions from equipment leaks at the process unit. However, it is recommended that unit-specific correlations are only developed in cases where the existing EPA correlations do not give reasonable mass emission estimates for the process unit. The focus of the chapter is on bagging equipment containing organic compounds, but similar procedures can be applied to bag equipment containing inorganic compounds as long as there are comparable analytical techniques for measuring the concentration of the inorganic compound.

This chapter is divided into four sections. In section 4.2, the methods for bagging equipment are discussed. Considerations for bagging each equipment type are discussed in section 4.3. In section 4.4, techniques used in the laboratory analysis of bagged samples are discussed. Section 4.4 also includes a description of a rigorous calibration procedure for the portable monitoring device that must be followed. Finally, in section 4.5, quality assurance and quality control (QA/QC) guidelines are provided.

4.2 SAMPLING METHODS

The emission rate from an equipment component is measured by bagging the component--that is, isolating the component from ambient air to collect any leaking compound(s). A tent (i.e., bag) made of material impermeable to the compound(s) of interest is constructed around the leak interface of the piece of equipment. A known rate of carrier gas is induced through the bag and a sample of the gas from the bag is collected and analyzed to determine the concentration (in parts per million by volume [ppmv]) of leaking material. The concentration is measured using laboratory instrumentation and procedures. Mass emissions are calculated based on the measured concentration and the flow rate of carrier gas through the bag.

In some cases, it may be necessary to collect liquid leaking from a bagged equipment piece. Liquid can either be dripping from the equipment piece prior to bagging, and/or be formed as condensate within the bag. If liquid accumulates in the bag, then the bag should be configured so that there is a low point to collect the liquid. The time in which the liquid accumulates should be recorded. The accumulated liquid should then be taken to the laboratory and transferred to a graduated cylinder to measure the volume of organic material. Based on the volume of organic material in the cylinder (with the volume of water or nonorganic material subtracted out), the density of the organic material, and the time in which the liquid accumulated, the organic liquid leak rate can be calculated. Note that the density can be assumed to be equivalent to the density of organic material in the equipment piece, or, if sufficient volume is collected, can be measured using a hydrometer. It should be noted that in some cases condensate may form a light coating on the inside surface of the bag, but will not accumulate. In these cases, it can be assumed that an equilibrium between condensation and evaporation has been reached and that the vapor emissions are equivalent to total emissions from the source.

When bagging an equipment piece, the enclosure should be kept as small as practical. This has several beneficial effects:

- The time required to reach equilibrium is kept to a minimum;
- The time required to construct the enclosure is minimized;
- A more effective seal results from the reduced seal area; and
- Condensation of heavy organic compounds inside the enclosure is minimized or prevented due to reduced residence time and decreased surface area available for heat transfer.

Two methods are generally employed in sampling source enclosures: the vacuum method and the blow-through method. Both methods involve enclosing individual equipment pieces with a bag and setting up a sampling train to collect two samples of leaking vapors to be taken to the laboratory for analysis. Both methods require that a screening value be obtained from the equipment piece prior to and after the equipment piece is enclosed. The methods differ in the ways in which the carrier gas is conveyed through the bag. In the vacuum method, a vacuum pump is used to pull air through the bag. In the blow-through method, a carrier gas such as nitrogen (or other inert gas) is blown into the bag.

In general, the blow-through method has advantages over the vacuum method. These advantages are as follows.

- (1) The blow-through method is more conducive to better mixing in the bag.
- (2) The blow-through method minimizes ambient air in the bag and thus reduces potential error associated with background organic compound concentrations. (For this reason the blow-through method is especially preferable when measuring the leak rate from components with zero or very low screening values.)
- (3) The blow-through method minimizes oxygen concentration in the bag (assuming air is not used as the carrier gas) and the risk of creating an explosive environment.
- (4) In general, less equipment is required to set up the blow-through method sampling train.

However, the blow-through method does require a carrier gas source, and preferably the carrier gas should be inert and free

of any organic compounds and moisture. The vacuum method does not require a special carrier gas.

Details of the sampling train of each of these bagging methods are discussed in sections 4.2.1 and 4.2.2, respectively. These sections also contain summaries of the steps of the sampling procedure for each method. For both methods, the approach described above for collecting and measuring liquid leak rates can be utilized. In addition to the sampling descriptions presented in the following sections, the quality control and assurance guidelines presented in section 4.5 must also be followed when bagging equipment.

4.2.1 Vacuum Method

The sampling train used in the vacuum method is depicted in figure 4-1. The train can be mounted on a portable cart, which can be moved around the process unit from component to component. The major equipment items in the sampling train are the vacuum pump used to draw air through the system, and the dry gas meter used to measure the flow rate of gas through the train. In previous studies that the EPA conducted, a 4.8-cubic feet per minute Teflon® ring piston-type vacuum pump equipped with a 3/4-horsepower, air-driven motor was used. Other equipment that may be used in the train includes valves, copper and stainless steel tubing, Teflon® tubing and tape, thermometer, pressure-reading device, liquid collection device, and air-driven diaphragm sampling pumps. It also may be necessary to use desiccant preceding the dry gas meter to remove any moisture.

The bag is connected by means of a bulkhead fitting and Teflon® tubing to the sampling train. A separate line is connected from the bag to a pressure-reading device to allow continuous monitoring of the pressure inside the bag. If a significant vacuum exists inside the bag when air is being pulled through, a hole is made in the opposite side of the bag from the outlet to the sampling train. This allows air to enter the bag more easily and, thus, reduces the vacuum in the enclosure. However, it is important to maintain a vacuum in the bag, since VOC could be lost through the hole if the bag became pressurized.

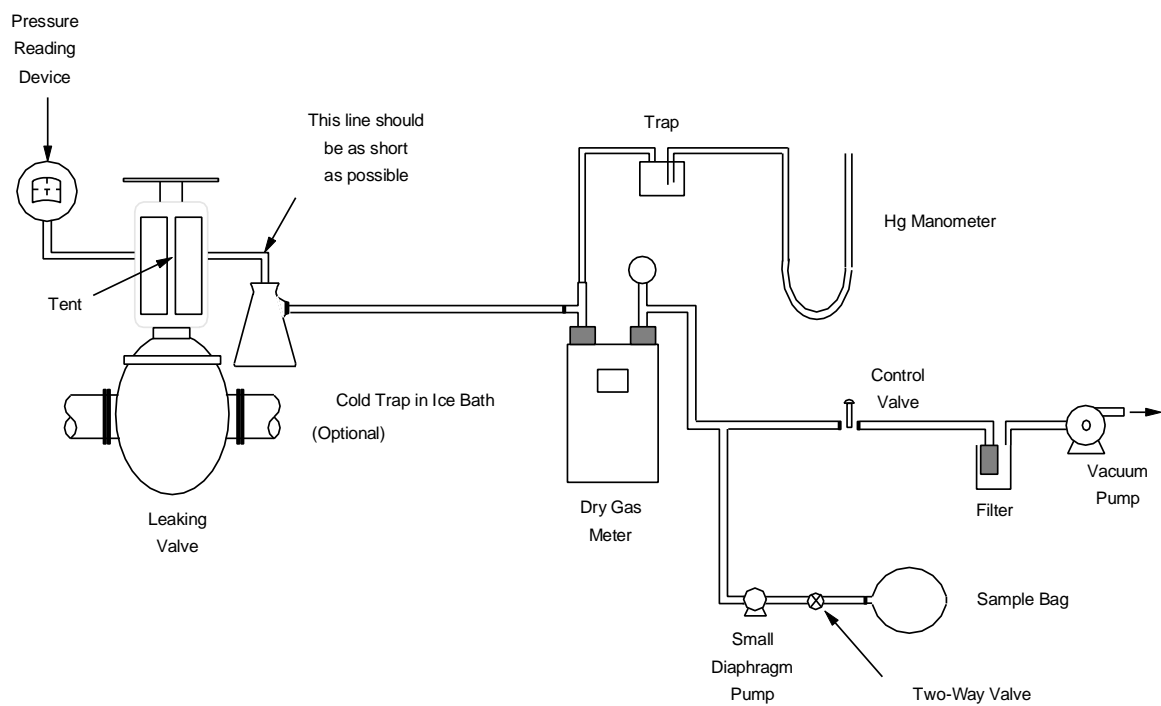

Figure 4-1. Sampling train for bagging a source using the vacuum method.

In practice, it has been found that only a very slight vacuum (0.1 inches of water) is present in the bag during most of the sampling, even in the absence of a hole through the bag wall. Sufficient air enters around the seals to prevent the development of a significant vacuum in the bag. A small diaphragm sampling pump can be used to collect two samples into sample bags or canisters, which are then transported to the laboratory for analysis.

The diaphragm pump can also be used to collect a background sample of the ambient air near the bagged component. The concentration in the background bag is subtracted from the average concentration in the sample bags when calculating the leak rate. Often this correction is insignificant (particularly for components with high leak rates or in cases where there is no detectable volatile organic compound (VOC) concentration measured by the portable monitoring device), and collection of a background bag is optional. However, in some cases collection of a background bag is important so that emission rates are not biased high.

Any liquid that accumulates in the bag should be collected using the approach described in section 4.2. Note that if there is a concern that condensation will occur in equipment downstream from the bag outlet, a cold trap can be placed as close to the bag outlet as possible to remove water or heavy organic compounds that may condense downstream. Any organic condensate that collects in the cold trap must be measured to calculate the total leak rate.

The flow rate through the system can be varied by throttling the flow with a control valve immediately upstream of the vacuum pump. Typical flow rates are approximately 60 liters per minute (ℓ/min) or less. A good flow rate to use is one in which a balance can be found between reaching equilibrium conditions and having a high enough concentration of organic compounds in the bag outlet to accurately measure the concentration in the laboratory. As the flow rate is decreased, the concentration of organic compounds increases in the gas flowing through the

sampling system. The flow rate should be adjusted to avoid any operations with an explosive mixture of organic compounds in air. It may also be possible to increase the flow rate in order to minimize liquid condensation in the bag.

The flow rate should be set to a constant rate and kept at that rate long enough for the system to reach equilibrium. To determine if equilibrium conditions have been reached, a portable monitoring device can be used to indicate if the outlet concentration has stabilized.

It is not recommended that the vacuum method be used to measure the leak rate from equipment that have low screening values (approximately 10 ppmv or less), because considerable error can be introduced due to the background organic concentration in the ambient air that is pulled through the bag.

In summary, the vacuum sampling procedure consists of the following steps.

- (1) Determine the composition of material in the designated equipment component, and the operating conditions of the component.
- (2) Obtain and record a screening value with the portable monitoring instrument.
- (3) Cut a bag from appropriate material (see section 4.3) that will easily fit over the equipment component.
- (4) Connect the bag to the sampling train.
- (5) If a cold trap is used, immerse the trap in an ice bath.
- (6) Note the initial reading of the dry gas meter.
- (7) Start the vacuum pump and a stopwatch simultaneously. Make sure a vacuum exists within the bag.
- (8) Record the temperature and pressure at the dry gas meter.
- (9) Observe the VOC concentration at the vacuum pump exhaust with the monitoring instrument. Make sure concentration stays below the lower explosive limit.
- (10) Record the temperature, pressure, dry gas meter reading, outlet VOC concentration and elapsed time every 2 to 5 minutes (min).

- (11) Collect 2 gas samples from the discharge of the diaphragm sampling pump when the outlet concentration stabilizes (i.e., the system is at equilibrium).
- (12) Collect a background bag (optional).
- (13) Collect any liquid that accumulated in the bag as well as in the cold trap (if used) in a sealed container.
- (14) Take a final set of readings and stop the vacuum pump.
- (15) Transport all samples to the laboratory, along with the data sheet.
- (16) Remove the bag.
- (17) Rescreen the source with the portable monitoring instrument and record.

Based on the data collected in the steps described above, mass emissions are calculated using the equation presented in table 4-1.

4.2.2 Blow-Through Method

The sampling train for the blow-through method is presented in figure 4-2. The temperature and oxygen concentrations are measured inside the bag with a thermocouple (or thermometer) and an oxygen/combustible gas monitor. The carrier gas is metered into the bag through one or two tubes (two tubes provide for better mixing) at a steady rate throughout the sampling period. The flow rate of the carrier gas is monitored in a gas rotameter calibrated to the gas. Typical flow rates are approximately 60 l/min or less. It is preferable to use an inert gas such as nitrogen for the blow-through method so as to minimize the risk of creating an explosive environment inside the bag. Also, the carrier gas should be free of any organic compounds and moisture. The pressure in the bag should never exceed 1 pound per square inch gauge (psig).

The flow rate through the bag can be varied by adjusting the carrier gas regulator. As mentioned in section 4.2.1, a good flow rate to use is one in which a balance can be found between reaching equilibrium conditions and having a high enough

TABLE 4-1. CALCULATION PROCEDURES FOR LEAK RATE WHEN USING THE VACUUM METHOD

$$\text{Leak Rate (kg/hr)} = \frac{9.63 \times 10^{-10} (Q)(MW)(GC)(P)}{T + 273.15} + \frac{(\rho)(V_L)}{16.67(t)}$$

where:

9.63×10^{-10} = A conversion factor using the gas constant:

$$\frac{^{\circ}\text{K} \times 10^6 \times \text{kg-mol} \times \text{min}}{\ell \times \text{hour} \times \text{mmHg}} ;$$

- Q = Flow rate out of bag (ℓ /min);
- MW^a = Molecular weight of organic compound(s) in the sample bag^c or alternatively in the process stream contained within the equipment piece being bagged (kg/kg-mol);
- GC^b = Sample bag organic compound concentration (ppmv) minus background bag organic compound concentration^c (ppmv);
- P = Absolute pressure at the dry gas meter (mmHg);
- T = Temperature at the dry gas meter ($^{\circ}$ C);
- ρ = Density of organic liquid collected (g/ml);
- V_L = Volume of liquid collected (ml);
- 16.67 = A conversion factor to adjust term to units of kilograms per hour (g \times hr)/(kg \times min)
- t = Time in which liquid is collected (min); and

^aFor mixtures calculate MW as:

$$= \frac{\sum_{i=1}^n \text{MW}_i X_i}{\sum_{i=1}^n X_i}$$

where:

MW_i = Molecular weight of organic compound i;

X_i = Mole fraction of organic compound i; and

n = Number of organic compounds in mixture.

^bFor mixtures, the value of GC is the total concentration of all the organic compounds in the mixture.

^cCollection of a background bag is optional. If a background bag is not collected, assume the background concentration is zero.

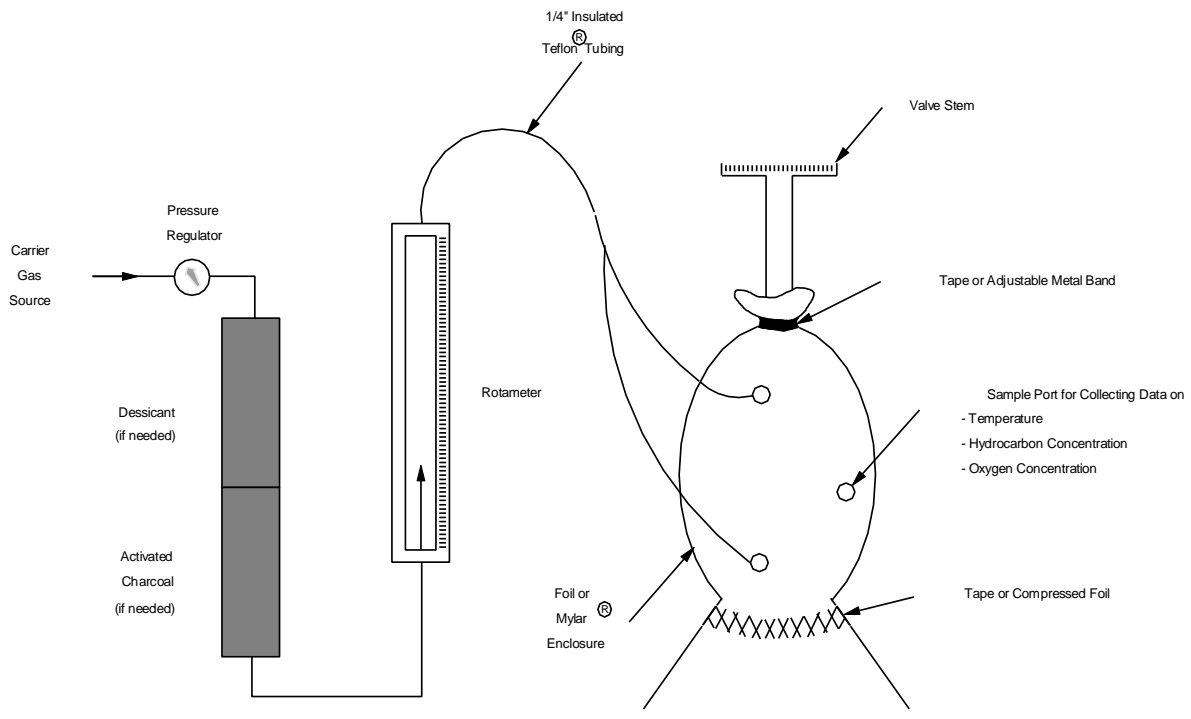

Figure 4-2. Equipment Required for the Blow-Through Sampling Technique

concentration of organic compounds in the bag outlet to accurately measure the concentration in the laboratory. Adjustments to the flow rate may also help minimize liquid condensation in the bag. Any liquid that does accumulate in the bag should be collected using the approach described in section 4.2.

The carrier gas flow rate should be set to a constant rate and kept at that rate long enough for the system to reach equilibrium. In addition to the carrier gas flow through the bag, some ambient air may enter the bag if it is not airtight. The oxygen measurements are used to determine the flow of ambient air through the bag. The oxygen measurements are also an indication of the quality of the bagging procedure (the lower the oxygen concentration the better). Once oxygen concentration falls below 5 percent, the portable monitoring instrument is used to check organic compound concentrations at several locations within the bag to ensure that the bag contents are at steady state.

Once the bag contents are at steady state, two gas samples are drawn out of the bag for laboratory analysis using a portable sampling pump. It may also be necessary to collect a background bag sample, particularly if the source had screened at zero and if there is still a detectable level of oxygen in the bag. However, collection of a background bag is optional.

In summary, the blow-through method consists of the following steps, which assume nitrogen is used as the carrier gas.

- (1) Determine the composition of the material in the designated equipment component, and the operating conditions of the component.
- (2) Screen the component using the portable monitoring instrument.
- (3) Cut a bag that will easily fit over the equipment component.

- (4) Connect tubing from the nearest nitrogen source to a rotameter stand.
- (5) Run tubing from the rotameter outlet to a "Y" that splits the nitrogen flow into two pieces of tubing and insert the tubes into openings located on either side of the bag.
- (6) Turn on the nitrogen flow and regulate it at the rotameter to a constant rate and record the time.
- (7) After the nitrogen is flowing, wrap aluminum foil around those parts of the component where air could enter the bag-enclosed volume.
- (8) Use duct tape, wire, and/or rope to secure the bag to the component.
- (9) Put a third hole in the bag roughly equidistant from the two carrier gas-fed holes.
- (10) Measure the oxygen concentration in the bag by inserting the lead from an oxygen meter into the third hole. Adjust the bag (i.e., modify the seals at potential leak points) until the oxygen concentration is less than 5 percent.
- (11) Measure the temperature in the bag.
- (12) Check the organic compound concentration at several points in the bag with the portable monitoring instrument to ensure that carrier gas and VOC are well mixed throughout the bag.
- (13) Collect samples in sample bags or canisters by drawing a sample out of the bag with a portable sampling pump.
- (14) Collect a background bag (optional).
- (15) Remove the bag and collect any liquid that accumulated in the bag in a sealed container. Note the time over which the liquid accumulated.
- (16) Rescreen the source.

Table 4-2 gives equations used to calculate mass emission rates when using the blow-through method. An adjustment is provided for the leak rate equation in table 4-2 to account for the total flow through the bag. This adjustment is recommended and represents an improvement over previous versions

TABLE 4-2. CALCULATION PROCEDURES FOR LEAK RATE
WHEN USING THE BLOW-THROUGH METHOD

$$\text{Leak Rate (kg/hr)} = \left(\frac{1.219 \times 10^{-5} (Q) (MW) (GC)}{T + 273.15} + \frac{(\rho) (V_L)}{16.67 (t)} \right) \times \left(\frac{10^6 \text{ppmv}}{10^6 \text{ppmv} - GC} \right)$$

where:

1.219×10^{-5} = A conversion factor taking into account the gas constant and assuming a pressure in the tent of 1 atmosphere:

$$\frac{^{\circ}\text{K} \times 10^6 \times \text{kg-mol}}{\text{m}^3} ;$$

Q = flow rate out of tent (m^3/hr);

$$= \frac{\text{N}_2 \text{ Flow Rate (l/min)}}{1 - [\text{Tent Oxygen Conc. (volume \%)/21]} \times \frac{[0.06 (\text{m}^3/\text{min})]}{(\text{l/hr})}$$

MW^a = Molecular weight of organic compounds in the sample bag or alternatively in the process stream contained within the equipment piece being bagged (kg/kg-mol);

GC^b = Sample bag organic compound concentration (ppmv), corrected for background bag organic compound concentration (ppmv);^c

T = Temperature in tent ($^{\circ}\text{C}$);

ρ = Density of organic liquid collected (g/ml);

V_L = Volume of liquid collected (ml);

16.67 = A conversion factor to adjust term to units of Kilograms per hour ($\text{g} \times \text{hr}/(\text{kg} \times \text{min})$); and

t = Time in which liquid is collected (min).

^aFor mixtures calculate MW as:

$$= \frac{\sum_{i=1}^n MW_i X_i}{\sum_{i=1}^n X_i}$$

where:

MW_i = Molecular weight of organic compound i ;

TABLE 4-2. CALCULATION PROCEDURES FOR LEAK RATE
WHEN USING THE BLOW-THROUGH METHOD
(Continued)

X_i = Mole fraction of organic compound i ; and
 n = Number of organic compounds in mixture.

^bFor mixtures, the value of GC is the total concentration of all the organic compounds in the mixture.

^cCollection of a background bag is optional. If a background bag is not collected, assume the background concentration is zero. To correct for background concentration, use the following equation:

$$\text{GC (ppmv)} = \text{SB} - \left(\frac{\text{TENT}}{21} \times \text{BG} \right)$$

where:

SB = Sample bag concentration (ppmv);
TENT = Tent oxygen concentration (volume %); and
BG = Background bag concentration (ppmv)

of this document for quantifying mass emissions from the blow through method.

4.3 SOURCE ENCLOSURE

In this section, choosing a bagging material and the approach for bagging specific equipment types are discussed. An important criteria when choosing the bagging material is that it is impermeable to the specific compounds being emitted from the equipment piece. This criteria is also applicable for sample gas bags that are used to transport samples to the laboratory. A bag stability test over time similar to the Flexible Bag Procedure described in section 5.3.2 of the EPA method 18 is one way to check the suitability of a bagging material.¹ After a bag has been used, it must be purged. Bags containing residual organic compounds that cannot be purged should be discarded. Mylar®, Tedlar®, Teflon®, aluminum foil, or aluminized Mylar® are recommended potential bagging materials. The thickness of the bagging material can range from 1.5 to 15 millimeters (mm), depending on the bagging configuration needed for the type of equipment being bagged, and the bagging material. Bag construction for individual sources is discussed in sections 4.3.1 through 4.3.5. For convenience, Mylar® will be used as an example of bagging material in the following discussions.

4.3.1 Valves

When a valve is bagged, only the leak points on the valve should be enclosed. Do not enclose surrounding flanges. The most important property of the valve that affects the type of enclosure selected for use is the metal skin temperature where the bag will be sealed. At skin temperatures of approximately 200 °C or less, the valve stem and/or stem support can be wrapped with 1.5- to 2.0-mm Mylar® and sealed with duct tape at each end and at the seam. The Mylar® bag must be constructed to enclose the valve stem seal and the packing gland seal.

When skin temperatures are in excess of 200 °C, a different method of bagging the valve should be utilized. Metal bands, wires, or foil can be wrapped around all hot points that would be

in contact with the Mylar® bag material. Seals are then made against the insulation using duct tape or adjustable metal bands of stainless steel. At extremely high temperatures, metal foil can be used as the bagging material and metal bands used to form seals. At points where the shape of the equipment prevent a satisfactory seal with metal bands, the foil can be crimped to make a seal.

4.3.2 Pumps and Agitators

As with valves, a property of concern when preparing to sample a pump or agitator is the metal skin temperature at areas or points that are in contact with the bag material. At skin temperatures below 200 °C, Mylar® plastic and duct tape are satisfactory materials for constructing a bag around a pump or agitator seal. If the temperature is too high or the potential points of contact are too numerous to insulate, an enclosure made of aluminum foil can be constructed. This enclosure is sealed around the pump and bearing housing using silicone fabric insulating tape, adjustable metal bands, or wire.

The configuration of the bag will depend upon the type of pump. Most centrifugal pumps have a housing or support that connects the pump drive (or bearing housing) to the pump itself. The support normally encloses about one-half of the area between the pump and drive motor, leaving open areas on the sides. The pump can be bagged by cutting panels to fit these open areas. These panels can be made using thicker bagging material such as 14-mm Mylar®. In cases where supports are absent or quite narrow, a cylindrical enclosure around the seal can be made so that it extends from the pump housing to the motor or bearing support. As with the panels, this enclosure should be made with thicker bagging material to provide strength and rigidity.

Reciprocating pumps can present a somewhat more difficult bagging problem. If supports are present, the same type of two-panel Mylar® bag can be constructed as that for centrifugal pumps. In many instances, however, sufficiently large supports are not provided, or the distance between pump and driver is relatively long. In these cases, a cylindrical enclosure as

discussed above can be constructed. If it is impractical to extend the enclosure all the way from the pump seal to the pump driver, a seal can be made around the reciprocating shaft. This can usually be best completed by using heavy aluminum foil and crimping it to fit closely around the shaft. The foil is attached to the Mylar® plastic of the enclosure and sealed with the duct tape.

In cases where liquid is leaking from a pump, the outlet from the bag to the sampling train should be placed at the top of the bag and as far away from spraying leaks as practical. A low point should be formed in the bag to collect the liquid so that the volume of the liquid can be measured and converted to a mass rate.

4.3.3 Compressors

In general, the same types of bags that are suitable for pumps can be directly applied to compressors. However, in some cases, compressor seals are enclosed and vented to the atmosphere at a high-point vent. If the seals are vented to a high-point vent, this vent line can be sampled. A Mylar® bag can be constructed and sealed around the outlet of the vent and connected to the sampling train. If the high-point vents are inaccessible, the vent lines from the compressor seal enclosures can be disconnected at some convenient point between the compressor and the normal vent exit. Sampling is then conducted at this intermediate point. In other cases, enclosed compressor seals are vented by means of induced draft blowers or fans. In these cases, if the air flow rate is known or can be determined, the outlet from the blower/fan can be sampled to determine the emission rate.

4.3.4 Connectors

In most cases, the physical configurations of connectors lend themselves well to the determination of leak rates. The same technique can be used for a connector whether it is a flanged or a threaded fitting. To bag a connector with a skin temperature below 200 °C, a narrow section of Mylar® film is constructed to span the distance between the two flange faces or

the threaded fitting of the leaking source. The Mylar® is attached and sealed with duct tape. When testing connectors with skin temperatures above 200 °C, the outside perimeter of both sides of the connector are wrapped with heat-resistant insulating tape. Then, a narrow strip of aluminum foil can be used to span the distance between the connection. This narrow strip of foil can be sealed against the insulating tape using adjustable bands of stainless steel.

4.3.5 Relief Valves

Relief devices in gas/vapor service generally relieve to the atmosphere through a large-diameter pipe that is normally located at a high point on the process unit that it serves. The "horns" can be easily bagged by placing a Mylar® plastic bag over the opening and sealing it to the horn with duct tape. Because many of these devices are above grade level, accessibility to the sampling train may be limited or prevented. It is sometimes possible to run a long piece of tubing from the outlet connection on the bag to the sampling train located at grade level or on a stable platform.

As discussed previously in section 3.0, the purpose of pressure relief devices makes them inherently dangerous to sample, especially over a long period of time. If these equipment are to be sampled for mass emissions, special care and precautions should be taken to ensure the safety of the personnel conducting the field sampling.

4.4 ANALYTICAL TECHNIQUES

The techniques used in the laboratory analysis of the bagged samples will depend on the type of processes sampled. The following sections describe the analytical instrumentation and calibration, and analytical techniques for condensate. These are guidelines and are not meant to be a detailed protocol for the laboratory personnel. Laboratory personnel should be well-versed in the analysis of organic compound mixtures and should design their specific analyses to the samples being examined.

Also discussed is the calibration protocol for the portable monitoring instrument. When bagging data are collected, it is

critical that the screening value associated with mass emission rates is accurate. For this reason, a more rigorous calibration of the portable monitoring instrument is required than if only screening data are being collected.

4.4.1 Analytical Instrumentation

The use of analytical instrumentation in a laboratory is critical to accurately estimate mass emissions. The analytical instrument of choice depends on the type of sample being processed. Gas chromatographs (GC's) equipped with a flame ionization detector or electron capture detector are commonly used to identify individual constituents of a sample. Other considerations besides instrument choice are the type of column used, and the need for temperature programming to separate individual constituents in the process stream with sufficient resolution. For some process streams, total hydrocarbon analyses may be satisfactory.

4.4.2 Calibration of Analytical Instruments

Gas chromatographs should be calibrated with either gas standards generated from calibrated permeation tubes containing individual VOC components, or bottled standards of common gases. Standards must be in the range of the concentrations to be measured. If cylinder calibration gas mixtures are used, they must be analyzed and certified by the manufacturer to be within ± 2 percent accuracy, and a shelf life must be specified. Cylinder standards beyond the shelf life must either be reanalyzed or replaced.

Field experience indicates that certified accuracies of ± 2 percent are difficult to obtain for very low-parts per million (ppm) calibration standards (< 10 ppm). Users of low-parts per million calibration standards should strive to obtain calibration standards that are as accurate as possible. The accuracy must be documented for each concentration standard.

The results of all calibrations should be recorded on prepared data sheets. Table 4-3 provides an example of a data collection form for calibrating a GC. If other analytical instruments are used to detect the organic compounds from liquid

TABLE 4-3. EXAMPLE GC CALIBRATION DATA SHEET

Plant ID _____
Instrument ID _____
Analyst Name _____

Date	Time	Certified Gas Conc. (ppmv)	Instrument Reading (ppmv)	Comments
_____	_____	_____	_____	_____
_____	_____	_____	_____	_____
_____	_____	_____	_____	_____
_____	_____	_____	_____	_____
_____	_____	_____	_____	_____
_____	_____	_____	_____	_____
_____	_____	_____	_____	_____
_____	_____	_____	_____	_____
_____	_____	_____	_____	_____
_____	_____	_____	_____	_____
_____	_____	_____	_____	_____
_____	_____	_____	_____	_____
_____	_____	_____	_____	_____
_____	_____	_____	_____	_____
_____	_____	_____	_____	_____
_____	_____	_____	_____	_____
_____	_____	_____	_____	_____
_____	_____	_____	_____	_____
_____	_____	_____	_____	_____
_____	_____	_____	_____	_____

samples, they should be calibrated according to standard calibration procedures for the instrument.

4.4.3 Analytical Techniques for Condensate

Any condensate collected should be brought to the laboratory sealed in the cold trap flask. This material is transferred to a graduated cylinder to measure the volume collected. If there is enough volume to make it feasible, the organic layer should be separated from the aqueous layer (if present) and weighed to determine its density. If water-miscible organic compounds are present, both the aqueous and organic phases should be analyzed by GC to determine the total volume of organic material.

4.4.4. Calibration Procedures for the Portable Monitoring Instrument

To generate precise screening values, a rigorous calibration of the portable monitoring instrument is necessary. Calibrations must be performed at the start and end of each working day, and the instrument reading must be within 10 percent of each of the calibration gas concentrations. A minimum of five calibration gas standards must be prepared including a zero gas standard, a standard approaching the maximum readout of the screening instrument, and three standards between these values. If the monitoring instrument range is from 0 to 10,000 ppmv, the following calibration gases are required:

- A zero gas (0-0.2 ppm) organic in air standard;
- A 9.0 ppm (8-10 ppm) organic in air standard;
- A 90 ppm (80-100 ppm) organic in air standard;
- A 900 ppm (800-1,000 ppm) organic in air standard; and
- A 9,000 ppm (8,000-10,000 ppm) organic in air standard.

The same guidelines for the analysis and certification of the calibration gases as described for calibrating laboratory analytical instruments must be followed for calibrating the portable monitoring instrument.

4.5 QUALITY CONTROL AND QUALITY ASSURANCE GUIDELINES

To ensure that the data collected during the bagging program is of the highest quality, the following QC/QA procedures must be followed. Quality control requirements include procedures to be

followed when performing equipment leak mass emissions sampling. Quality assurance requirements include accuracy checks of the instrumentation used to perform mass emissions sampling. Each of these QC/QA requirements are discussed below.

4.5.1 Quality Control Procedures

A standard data collection form must be prepared and used when collecting data in the field. Tables 4-4 and 4-5 are examples of data collection forms for the blow-through and vacuum methods of mass emissions sampling, respectively.

In addition to completing the data collection forms, the following guidelines need to be adhered to when performing the bagging analysis:

- Background levels near equipment that is selected for bagging must not exceed 10 ppmv, as measured with the portable monitoring device.
- Screening values for equipment that is selected for bagging must be readable within the spanned range of the monitoring instruments. If a screening value exceeds the highest reading on the meter (i.e., "pegged reading"), a dilution probe should be used, or in the event that this is not possible, the reading should be identified as pegged.
- Only one piece of equipment can be enclosed per bag; a separate bag must be constructed for each equipment component.
- A separate sample bag must be used for each equipment component that is bagged. Alternatively, bags should be purged and checked for contamination prior to reuse.
- A GC must be used to measure the concentrations from gas samples.
- Gas chromatography analyses of bagged samples must follow the analytical procedures outlined in the EPA method 18.
- To ensure adequate mixing within the bag when using the blow-through method, the dilution gas must be directed onto the equipment leak interface.
- To ensure that steady-state conditions exist within the bag, wait at least five time constants (volume of bag dilution/gas flow rate) before withdrawing a sample for recording the analysis.

TABLE 4-4. EXAMPLE DATA COLLECTION FORM FOR FUGITIVE EMISSIONS
BAGGING TEST (BLOW-THROUGH METHOD)

Equipment Type _____	Component ID _____
Equipment Category _____	Plant ID _____
Line Size _____	Date _____
Stream Phase (G/V, LL, HL) _____	Analysis Team _____
Barometric Pressure _____	_____
Ambient Temperature _____	Instrument ID _____
Stream Temperature _____	Stream Pressure _____
Stream Composition (Wt %) _____, _____	
_____, _____, _____	

<u>Time</u>	<u>Bagging Test Measurement Data</u>
_____	Initial Screening (ppmv) Equipment Piece _____ Bkgd. _____
_____	Background Bag Organic Compound Conc. (ppmv) ^a _____
_____	Dilution Gas Flow Rate (ℓ/min) _____
_____	Sample Bag 1 Organic Compound Conc. (ppmv) _____
_____	O ₂ Concentration (volume %) _____
_____	Bag Temperature (°C) _____
_____	Dilution Gas Flow Rate (ℓ/min) _____
_____	Sample Bag 2 Organic Compound Conc. (ppmv) _____
_____	O ₂ Concentration (volume %) _____
_____	Bag Temperature (°C) _____
Condensate Accumulation: Starting Time _____ Final Time _____	
Organic Condensate Collected (ml) _____	
Density of Organic Condensate (g/ml) _____	
_____	Final Screening (ppmv) Equipment Piece _____ Bkgd. _____

^aCollection of a background bag is optional. However, it is recommended in cases where the screening value is less than 10 ppmv and there is a detectable oxygen level in the bag.

TABLE 4-5. EXAMPLE DATA COLLECTION FORM FOR FUGITIVE EMISSIONS
BAGGING TEST (VACUUM METHOD)

Equipment Type _____	Component ID _____
Equipment Category _____	Plant ID _____
Line Size _____	Date _____
Stream Phase (G/V, LL, HL) _____	Analysis Team _____
Barometric Pressure _____	_____
Ambient Temperature _____	Instrument ID _____
Stream Temperature _____	Stream Pressure _____
Stream Composition (Wt %) _____	_____
_____	_____

<u>Time</u>	<u>Bagging Test Measurement Data</u>
_____	Initial Screening (ppmv) Equipment Piece ^a _____ Bkgd. _____
_____	Background Bag Organic Compound Conc. (ppmv) ^b _____
_____	Dry Gas Meter Reading (ℓ/min) _____
_____	Sample Bag 1 Organic Compound Conc. (ppmv) _____
_____	Vacuum Check in Bag (Y/N) (Must be YES to collect sample.)
_____	Dry Gas Meter Temperature ^c (°C) _____
_____	Dry Gas Meter Pressure ^c (mmHg) _____
_____	Dry Gas Meter Reading (ℓ/min) _____
_____	Sample Bag 2 Organic Compound Conc. (ppmv) _____
_____	Vacuum Check in Bag (Y/N) (Must be YES to collect sample.)
_____	Dry Gas Meter Temperature ^c (°C) _____
_____	Dry Gas Meter Pressure ^c (mmHg) _____
Condensate Accumulation: Starting Time _____ Final Time _____	
Organic Condensate Collected (ml) _____	
Density of Organic Condensate (g/ml) _____	
_____	Final Screening (ppmv) Equip. Piece ^a _____ Bkgd. _____

^aThe vacuum method is not recommended if the screening value is approximately 10 ppmv or less.

^bCollection of a background bag is optional.

^cPressure and temperature are measured at the dry gas meter.

- The carrier gas used in the blow-through method of bagging should be analyzed by GC before it is used, and the concentration of organic compounds in the sample should be documented. For cylinder purge gases, one gas sample should be analyzed. For plant purge gas systems, gas samples should be analyzed with each bagged sample unless plant personnel can demonstrate that the plant gas remains stable enough over time to allow a one-time analysis.
- The portable monitoring instrument calibration procedure described in section 4.4.4 should be performed at the beginning and end of each day.

4.5.2 Quality Assurance Procedures

Accuracy checks on the laboratory instrumentation and portable monitoring device must be performed to ensure data quality. These checks include a leak rate check performed in the laboratory, blind standards to be analyzed by the laboratory instrumentation, and drift checks on the portable monitoring device.

4.5.2.1 Leak Rate Check

A leak rate check is normally performed in the laboratory by sampling an artificially induced leak rate of a known gas. This can clarify the magnitude of any bias in the combination of sampling/test method, and defines the variance in emissions estimation due to the sampling. If the result is outside the 80 to 120 percent recovery range, the problem must be investigated and corrected before sampling continues. The problems and associated solutions should be noted in the test report.

Leak rate checks should be performed at least two times per week during the program. The leak rate checks should be conducted at two concentrations: (1) within the range of 10 multiplied by the calculated lower limit of detection for the laboratory analytical instrument; and (2) within 20 percent of the maximum concentration that has been or is expected to be detected in the field during the bagging program.

To perform a leak rate check, first induce a known flow rate with one of the known gas concentrations into a sampling bag.

For example, this can be done using a gas permeation tube of a known organic compound constituent. Next, determine the concentration of the gas using a laboratory analytical instrument and compare the results to the known gas concentration.

If the calculated leak rate is not within ± 20 percent of the induced leak rate, further analysis should be performed to determine the reason.

Areas that can potentially induce accuracy problems include:

- Condensation,
- Pluggage,
- Seal of bag not tight (leakage),
- Adsorption onto bag, and
- Permeation of bag.

The results of all accuracy checks should be recorded on prepared data sheets.

4.5.2.2 Blind Standards Preparation and Performance

Blind standards are analyzed by the laboratory instrumentation to ensure that the instrument is properly calibrated. Blind standards must be prepared and submitted at least two times per week during the program. The blind standards are prepared by diluting or mixing known gas concentrations in a prescribed fashion so that the resulting concentrations are known. The analytical results should be within ± 25 percent of the blind standard gas concentration. If the results are not within 25 percent of the blind standard concentration, further analyses must be performed to determine the reason. Use of blind standards not only defines the analytical variance component and analytical accuracy, but it can serve to point out equipment malfunctions and/or operator error before questionable data are generated.

4.5.2.3 Drift Checks

Drift checks need to be performed to ensure that the portable monitoring instrument remains calibrated. At a minimum, drift checks must be performed before and after a small group of components (i.e., two or three) are bagged. Preferably, drift

checks should be performed on the screening instrument immediately before and after each component is bagged. These checks should be performed by analyzing one of the calibration gases used to calibrate the portable monitoring instrument. The choice of calibration gas concentration should reflect the anticipated screening value of the next component to be monitored. For example, if a component had previously screened at 1,000 ppmv and been identified for bagging, the calibration standard should be approximately 900 ppmv.

Drift check data must be recorded on data sheets containing the information shown in the example in table 4-6. If the observed instrument reading is different from the certified value by greater than ± 20 percent, then a full multipoint calibration must be performed (see section 3.2.4.1). Also, all those components analyzed since the last drift check must be retested.

Drift checks should also be performed if flameout of the portable monitoring instrument occurs. Using the lowest calibration gas standard (i.e., approximately 9 ppmv standard), determine the associated response on the portable monitoring instrument. If the response is not within ± 10 percent of the calibration gas concentration, a full multipoint calibration is required before testing resumes.

4.6 REFERENCES

1. Code of Federal Regulations, Title 40, Part 60, Appendix A. Reference Method 21, Determination of Volatile Organic Compound Leaks. Washington, DC. U.S. Government Printing Office. Revised June 22, 1990.

5.0 ESTIMATION OF CONTROL EFFICIENCIES FOR EQUIPMENT LEAK CONTROL TECHNIQUES

5.1 INTRODUCTION

In this chapter, control techniques for reducing equipment leak emissions are described. There are two primary techniques for reducing equipment leak emissions: (1) modifying or replacing existing equipment, and (2) implementing a leak detection and repair (LDAR) program.

Modifying or replacing existing equipment is referred to in this chapter as an "equipment modification." Examples of equipment modifications include installing a cap on an open-ended line, replacing an existing pump with a sealless type, and installing on a compressor a closed-vent system that collects potential leaks and routes them to a control device. In section 5.2, possible equipment modifications for each of the equipment types are briefly described. Also, the estimated control efficiency is presented for each equipment modification.

An LDAR program is a structured program to detect and repair equipment that is identified as leaking. The focus of this chapter is LDAR programs for which a portable monitoring device is used to identify equipment leaks from individual pieces of equipment. In section 5.3, an approach is presented for estimating the control effectiveness of an LDAR program.

5.2 EQUIPMENT MODIFICATION CONTROL EFFICIENCY

Controlling emissions by modifying existing equipment is achieved by either installing additional equipment that eliminates or reduces emissions, or replacing existing equipment with sealless types. Equipment modifications for each equipment type are described in the following sections. A separate section

is included on closed-vent systems, which can be installed on more than one type of equipment. Equipment modifications that can be used for each equipment type are summarized in table 5-1. Table 5-1 also contains an approximate control efficiency for each modification.

5.2.1 Closed-Vent Systems

A closed-vent system captures leaking vapors and routes them to a control device. The control efficiency of a closed-vent system depends on the percentage of leaking vapors that are routed to the control device and the efficiency of the control device. A closed-vent system can be installed on a single piece of equipment or on a group of equipment pieces. For use on single pieces of equipment, closed-vent systems are primarily applicable to equipment types with higher potential emission rates, such as pumps, compressors, and pressure relief devices.

5.2.2 Pumps

Equipment modifications that are control options for pumps include routing leaking vapors to a closed-vent system (as discussed in section 5.2.1), installing a dual mechanical seal containing a barrier fluid, or replacing the existing pump with a sealless type.

5.2.2.1 Dual Mechanical Seals. A dual mechanical seal contains two seals between which a barrier fluid is circulated. Depending on the design of the dual mechanical seal, the barrier fluid can be maintained at a pressure that is higher than the pumped fluid or at a pressure that is lower than the pumped fluid. If the barrier fluid is maintained at a higher pressure than the pumped fluid, the pumped fluid will not leak to the atmosphere. The control efficiency of a dual mechanical seal with a barrier fluid at a higher pressure than the pumped fluid is essentially 100 percent, assuming both the inner and outer seal do not fail simultaneously.

If the barrier fluid is maintained at a lower pressure than the pumped fluid, a leak in the inner seal would result in the pumped fluid entering the barrier fluid. To prevent emissions of the pumped fluid to the atmosphere, a barrier fluid reservoir

TABLE 5-1. SUMMARY OF EQUIPMENT MODIFICATIONS

Equipment type	Modification	Approximate control efficiency (%)
Pumps	Sealless design	100 ^a
	Closed-vent system	90 ^b
	Dual mechanical seal with barrier fluid maintained at a higher pressure than the pumped fluid	100
Compressors	Closed-vent system	90 ^b
	Dual mechanical seal with barrier fluid maintained at a higher pressure than the compressed gas	100
Pressure relief devices	Closed-vent system	c
	Rupture disk assembly	100
Valves	Sealless design	100 ^a
Connectors	Weld together	100
Open-ended lines	Blind, cap, plug, or second valve	100
Sampling connections	Closed-loop sampling	100

^aSealless equipment can be a large source of emissions in the event of equipment failure.

^bActual efficiency of a closed-vent system depends on percentage of vapors collected and efficiency of control device to which the vapors are routed.

^cControl efficiency of closed vent-systems installed on a pressure relief device may be lower than other closed-vent systems, because they must be designed to handle both potentially large and small volumes of vapor.

system should be used. At the reservoir, the pumped fluid can vaporize (i.e., de-gas) and then be collected by a closed-vent system.

The actual emissions reduction achievable through use of dual mechanical seals depends on the frequency of seal failure. Failure of both the inner and outer seals could result in relatively large releases of the process fluid. Pressure monitoring of the barrier fluid may be used to detect failure of the seals, allowing for a quick response to a failure.

5.2.2.2 Sealless Pumps. When operating properly, a sealless pump will not leak because the process fluid cannot escape to the atmosphere. Sealless pumps are used primarily in processes where the pumped fluid is hazardous, highly toxic, or very expensive, and where every effort must be made to prevent all possible leakage of the fluid. Under proper operating conditions, the control efficiency of sealless pumps is essentially 100 percent; however, if a catastrophic failure of a sealless pump occurs, there is a potential for a large quantity of emissions.

5.2.3 Compressors

Emissions from compressors may be reduced by collecting and controlling the emissions from the seal or by improving seal performance. Shaft seals for compressors are of several different types--all of which restrict but do not eliminate leakage. In some cases, compressors can be equipped with ports in the seal area to evacuate collected gases using a closed-vent system. Additionally, for some compressor seal types, emissions can be controlled by using a barrier fluid in a similar manner as described for pumps.

5.2.4 Pressure Relief Valves

Equipment leaks from pressure relief valves (PRV's) occur as a result of improper reseating of the valve after a release, or if the process is operating too close to the set pressure of the PRV and the PRV does not maintain its seal. Emissions occurring from PRV's as a result of an overpressure discharge are not considered to be equipment leak emissions. There are two primary

alternatives for controlling equipment leaks from pressure relief devices: use of a rupture disk (RD) in conjunction with the PRV, or use of a closed-vent system.

5.2.4.1 Rupture Disk/Pressure Relief Valve Combination.

Although they are also pressure relief devices, RD's can be installed upstream of a PRV to prevent fugitive emissions through the PRV seat. Rupture disk/pressure relief valve combinations require certain design constraints and criteria to avoid potential safety hazards, which are not covered in this document. If the RD fails, it must be replaced. The control efficiency of the RD/PRV combination is assumed to be 100 percent when operated and maintained properly.

5.2.4.2 Closed-Vent System. A closed-vent system can be used to transport equipment leaks from a pressure relief device to a control device such as a flare. The equipment leak control efficiency for a closed-vent system installed on a pressure relief device may not be as high as the control efficiency that can be achieved by installing a closed-vent system on other equipment types. This is because emissions from pressure relief devices can be either high flow emissions during an overpressure incident or low flow emissions associated with equipment leaks, and it may be difficult to design a control device to efficiently handle both high and low flow emissions.

5.2.5 Valves

Emissions from process valves can be eliminated if the valve stem can be isolated from the process fluid. Two types of sealless valves are available: diaphragm valves and sealed bellows valves. The control efficiency of both diaphragm and sealed bellows valves is virtually 100 percent. However, a failure of these types of valves has the potential to cause temporary emissions much larger than those from other types of valves.

5.2.6 Connectors

In cases where connectors are not required for safety, maintenance, process modification, or periodic equipment removal, emissions can be eliminated by welding the connectors together.

5.2.7 Open-Ended Lines

Emissions from open-ended lines can be controlled by properly installing a cap, plug, or second valve to the open end. If a second valve is installed, the upstream valve should always be closed first after use of the valves to prevent the trapping of fluids between the valves. The control efficiency of these measures is assumed to be essentially 100 percent.

5.2.8 Sampling Connections

Emissions from sampling connections occur as a result of purging the sampling line to obtain a representative sample of the process fluid. Emissions from sampling connections can be reduced by using a closed-loop sampling system or by collecting the purged process fluid and transferring it to a control device or back to the process. The closed-loop sampling system is designed to return the purged fluid to the process at a point of lower pressure. A throttle valve or other device is used to induce the pressure drop across the sample loop. The efficiency of a closed-loop system is assumed to be 100 percent.

Alternatively, in some cases, sampling connections can be designed to collect samples without purging the line. If such a sampling connection is installed and no emissions to the atmosphere occur when a sample is collected, then the control efficiency can be assumed to be 100 percent.

5.3 LEAK DETECTION AND REPAIR CONTROL EFFECTIVENESS

An LDAR program is designed to identify pieces of equipment that are emitting sufficient amounts of material to warrant reduction of the emissions through repair. These programs are best applied to equipment types that can be repaired on-line, resulting in immediate emissions reduction, and/or to equipment types for which equipment modifications are not feasible. An LDAR program is best suited to valves and pumps, and can also be implemented for connectors.

For other equipment types, an LDAR program is not as applicable. Compressors are repaired in a manner similar to pumps; however, because compressors ordinarily do not have a spare for bypass, a process unit shutdown may be required for

repair. Open-ended lines are most easily controlled by equipment modifications. Emissions from sampling connections can only be reduced by changing the method of collecting the sample (since by definition equipment leak emissions are the material purged from the line), and cannot be reduced by an LDAR program. Safety considerations may preclude the use of an LDAR program on pressure relief valves.

In this section, an approach is presented that can be used to estimate the control effectiveness of any given LDAR program for light liquid pumps, gas valves, light liquid valves, and connectors. The approach is based on the relationship between the percentage of equipment pieces that are leaking and the corresponding average leak rate for all of the equipment. In this approach, the three most important factors in determining the control effectiveness are: (1) how a "leak" is defined, (2) the initial leak frequency before the LDAR program is implemented, and (3) the final leak frequency after the LDAR program is implemented. The leak definition (or action level) is the screening value at which a "leak" is indicated if a piece of equipment screens equal to or greater than that value. The leak frequency is the fraction of equipment with screening values equal to or greater than the leak definition.

Once these three factors are determined, a graph that plots leak frequency versus mass emission rate at several different leak definitions is used to predict emissions preceding and subsequent to implementing the LDAR program. In this way the emissions reduction (i.e., control effectiveness) associated with the LDAR program can be easily calculated.

A general description of the approach is provided in the subsections below. This is followed by an example application of the approach. The approach has been applied to determine the control effectiveness at Synthetic Organic Chemical Manufacturing Industry (SOCMI) and refinery process units for the following LDAR programs: (1) monthly LDAR with a leak definition of 10,000 parts per million by volume (ppmv), (2) quarterly LDAR with a leak definition of 10,000 ppmv, and (3) LDAR equivalent to that

specified in the proposed hazardous organic National Emission Standard for Hazardous Air Pollutants (NESHAP) equipment leaks negotiated regulation.¹ Tables 5-2 and 5-3 summarize the estimated control effectiveness for the three LDAR programs mentioned above at SOCFI process units and refineries, respectively. It should be noted that, to calculate the control effectiveness values presented in tables 5-2 and 5-3, assumptions were made that may not necessarily be applicable to specific process units. For example, the control effectiveness values in the tables are based on the assumption that the emission rate prior to implementing the LDAR program is the emission rate that would be predicted by the average emission factor. The best way to calculate the effectiveness of an LDAR program is by collecting and analyzing data at the specific process unit.

5.3.1 Approach for Estimating LDAR Control Effectiveness

As previously stated, the key parameters for estimating the control effectiveness of an LDAR program are the leak definition, the initial leak frequency, and the final leak frequency. The leak definition is a given part of an LDAR program. It can either be defined by the process unit implementing the program or by an equipment standard to which the process unit must comply. After the leak definition is established, the control effectiveness of an LDAR program can be estimated based on the average leak rate before the LDAR program is implemented, and the average leak rate after the program is in place.

Figures 5-1 through 5-4 are graphs presenting mass emission rate versus leak frequency for SOCFI-type process units at several leak definitions for gas valves, light liquid valves, light liquid pumps, and connectors, respectively. Figures 5-5 through 5-8 are graphs presenting mass emission rate versus leak frequency for refinery process units at several leak definitions for gas valves, light liquid valves, light liquid pumps, and connectors, respectively. Figures 5-9 through 5-15 are graphs presenting mass emission rate versus leak frequency for gas fittings, light liquid fittings, gas others, light liquid others, light liquid pumps, gas valves, and light liquid valves, for

TABLE 5-2. CONTROL EFFECTIVENESS FOR AN LDAR PROGRAM AT A SOCFI PROCESS UNIT

Equipment type and service	Control effectiveness (%)		HON reg neg ^a
	Monthly monitoring 10,000 ppmv leak definition	Quarterly monitoring 10,000 ppmv leak definition	
Valves - gas	87	67	92
Valves - light liquid	84	61	88
Pumps - light liquid	69	45	75
Connectors - all	b	b	93

a Control effectiveness attributable to the requirements of the proposed hazardous organic NESHAP equipment leak negotiated regulation are estimated based on equipment-specific leak definitions and performance levels.

b Data are not available to estimate control effectiveness.

TABLE 5-3. CONTROL EFFECTIVENESS FOR AN LDAR PROGRAM AT A REFINERY PROCESS UNIT

Equipment type and service	Control effectiveness (%)		
	Monthly monitoring 10,000 ppmv leak definition	Quarterly monitoring 10,000 ppmv leak definition	HON reg neg ^a
Valves - gas	88	70	96
Valves - light liquid	76	61	95
Pumps - light liquid	68	45	88
Connectors - all	b	b	81

a Control effectiveness attributable to the requirements of the proposed hazardous organic NESHAP equipment leak negotiated regulation are estimated based on equipment-specific leak definitions and performance levels.

b Data are not available to estimate control effectiveness.

SOCMI Gas Valve Equations

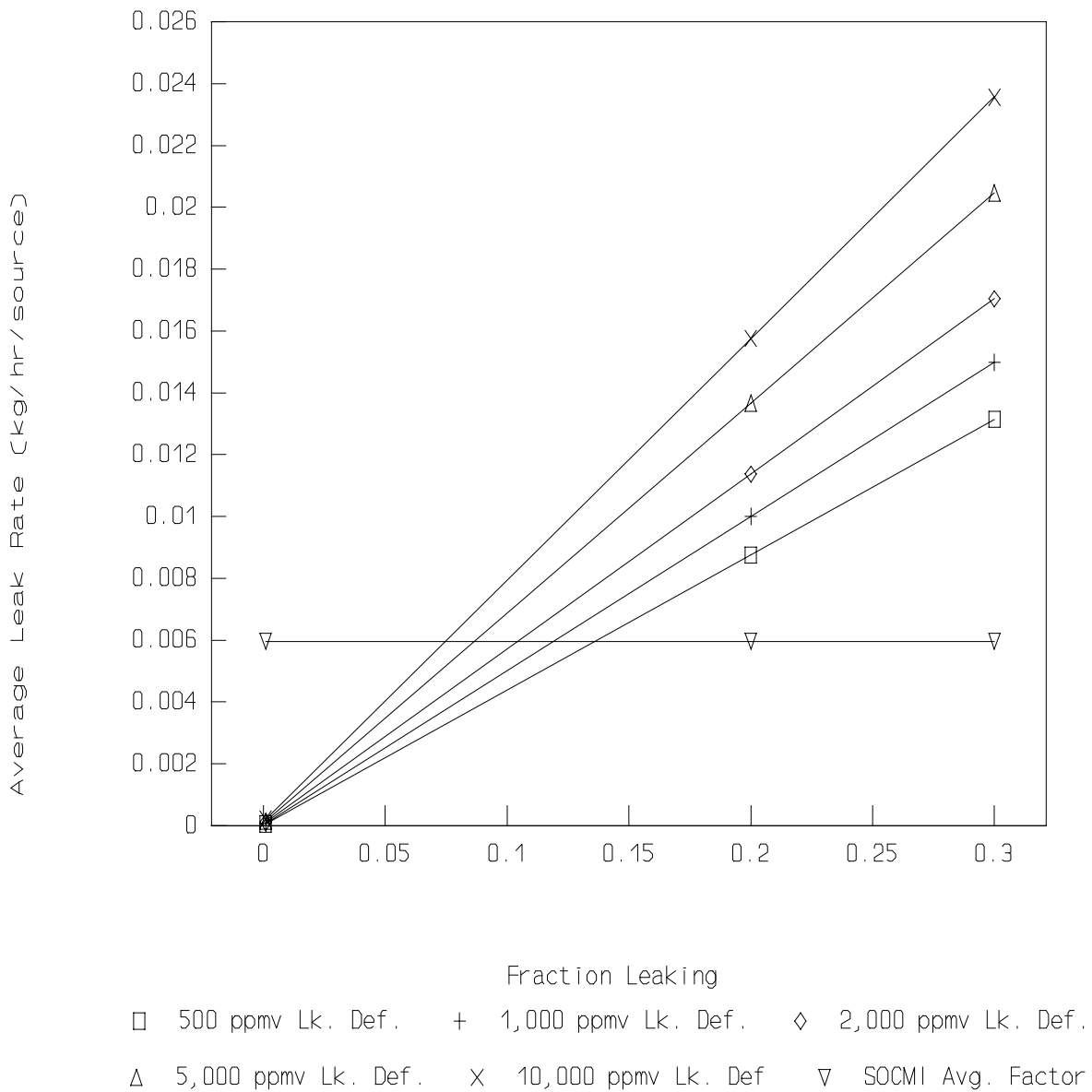

Figure 5-1. SOCMI Gas Valve Average Leak Rate Versus Fraction Leaking at Several Leak Definitions.

SOCMI Light Liquid Valve Equations

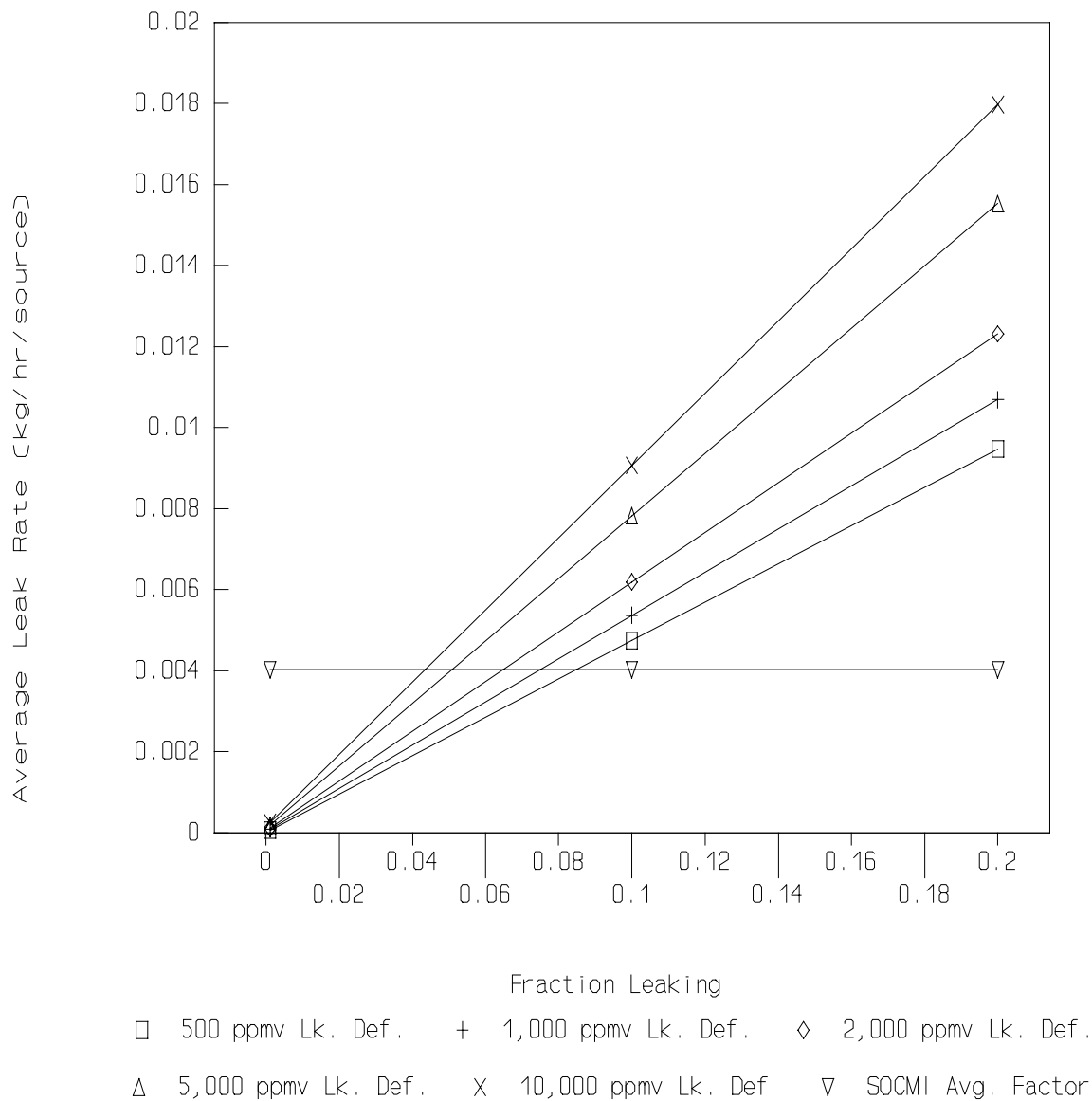
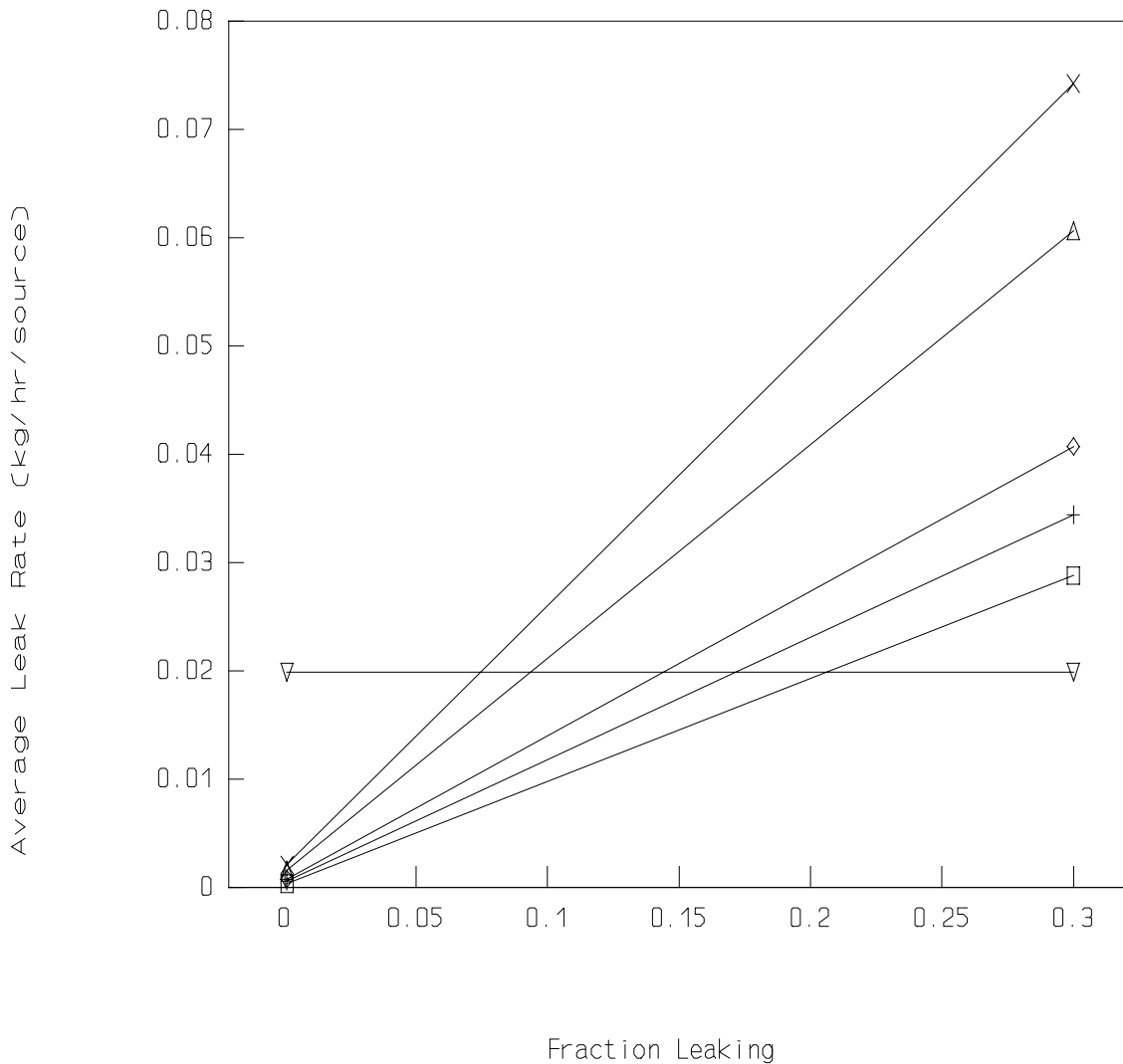

Figure 5-2. SOCMI Light Liquid Valve Average Mass Emission Rate Versus Fraction Leaking at Several Leak Definitions

SOCMI Light Liquid Pump Equations



□ 500 ppmv Lk. Def. + 1,000 ppmv Lk. Def. ◇ 2,000 ppmv Lk. Def.
 Δ 5,000 ppmv Lk. Def. X 10,000 ppmv Lk. Def. ▽ SOCMI Avg. Factor

Figure 5-3. SOCMI Light Liquid Pump Average Leak Rate Versus Fraction Leaking at Several Leak Definitions

SOCMI Connector Equations

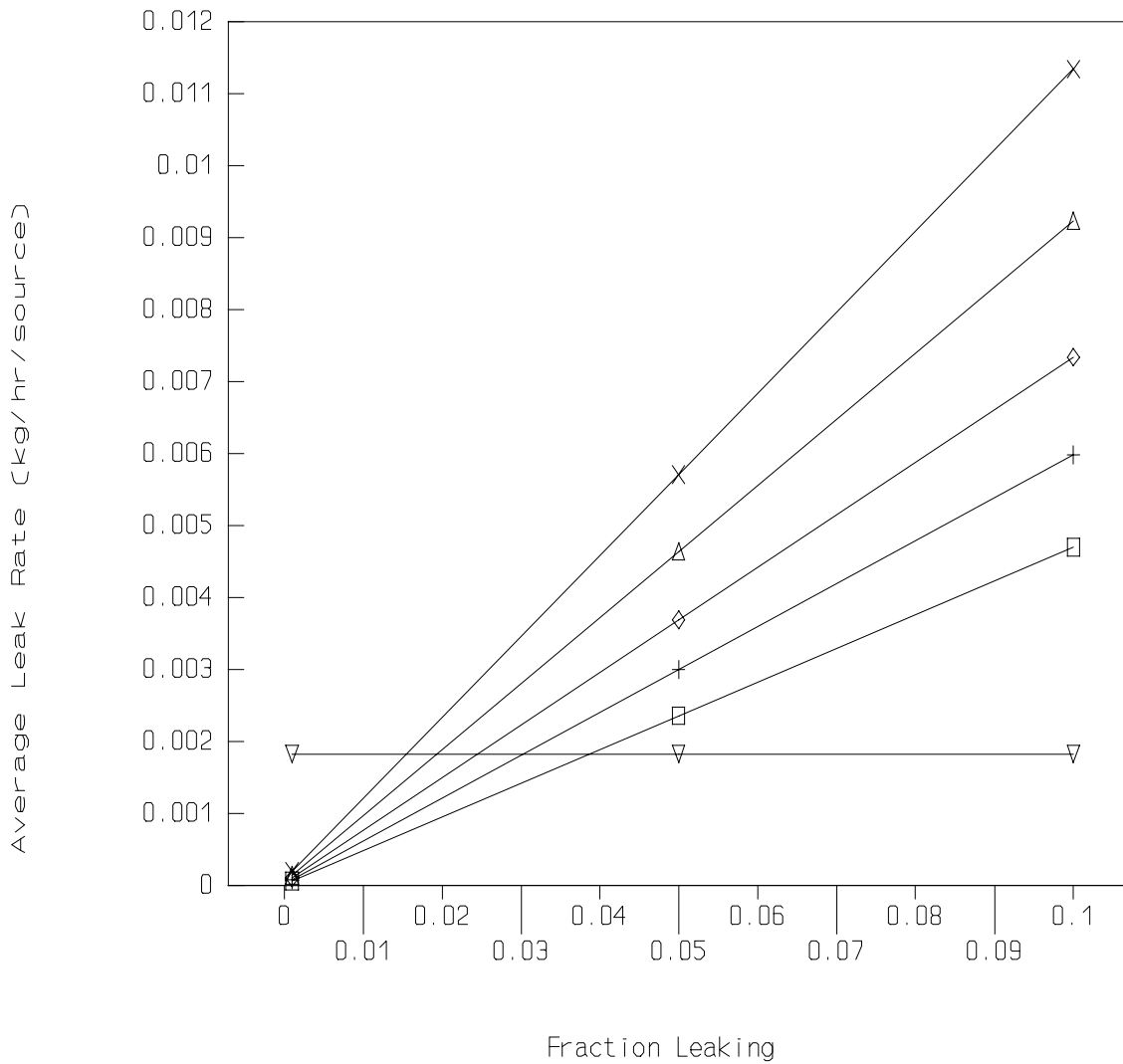

□ 500 ppmv Lk. Def. + 1,000 ppmv Lk. Def. ◇ 2,000 ppmv Lk. Def.
 △ 5,000 ppmv Lk. Def. × 10,000 ppmv Lk. Def. ▽ SOCMI Avg. Factor

Figure 5-4. SOCMI Connector Average Leak Rate Versus Fraction Leaking at Several Leak Definitions.

Refinery Gas Valve Equations

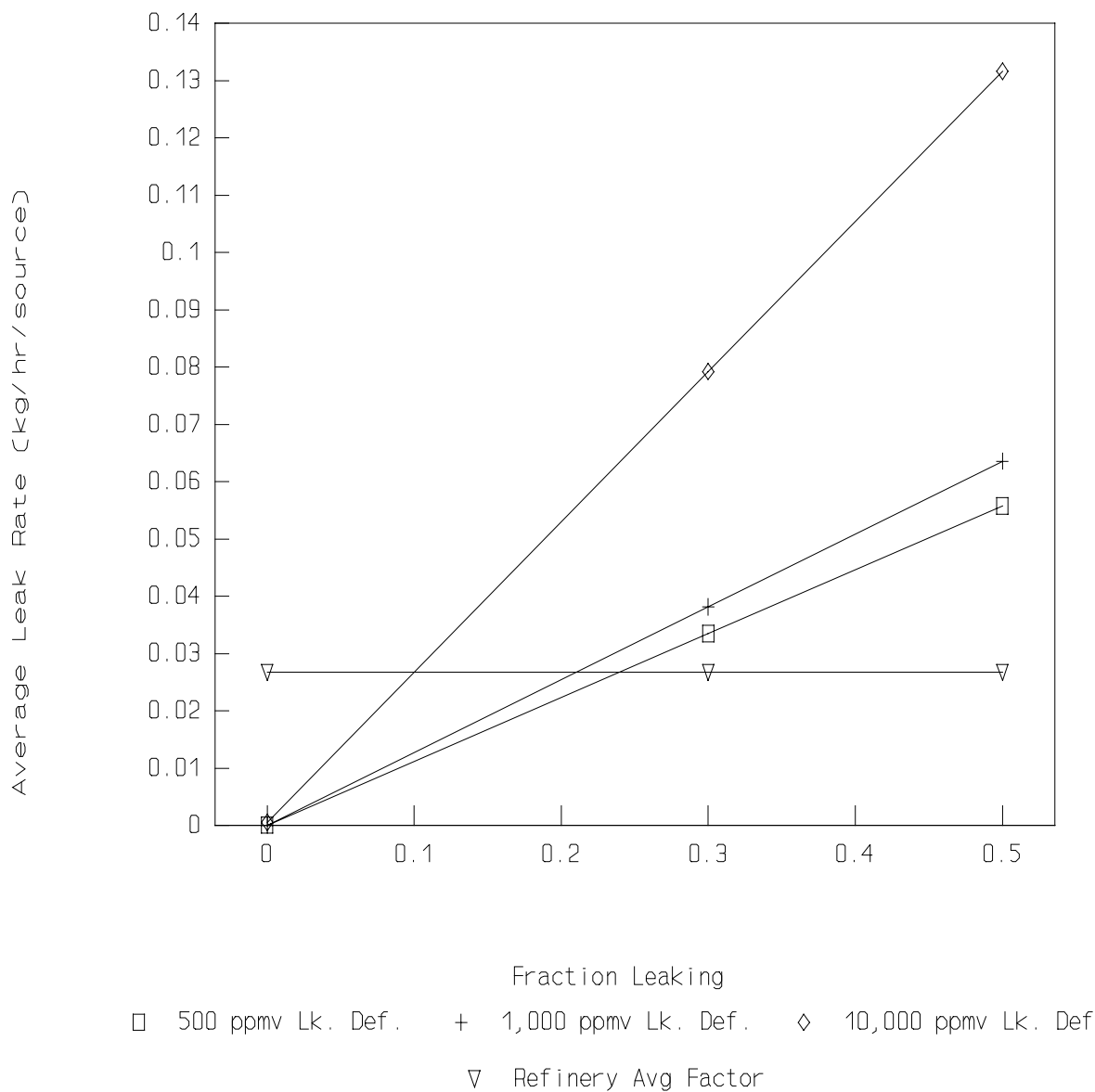

Figure 5-5. Refinery Gas Valve Average Leak Rate Versus Fraction Leaking at Several Leak Definitions

Refinery Light Liquid Valve Equations

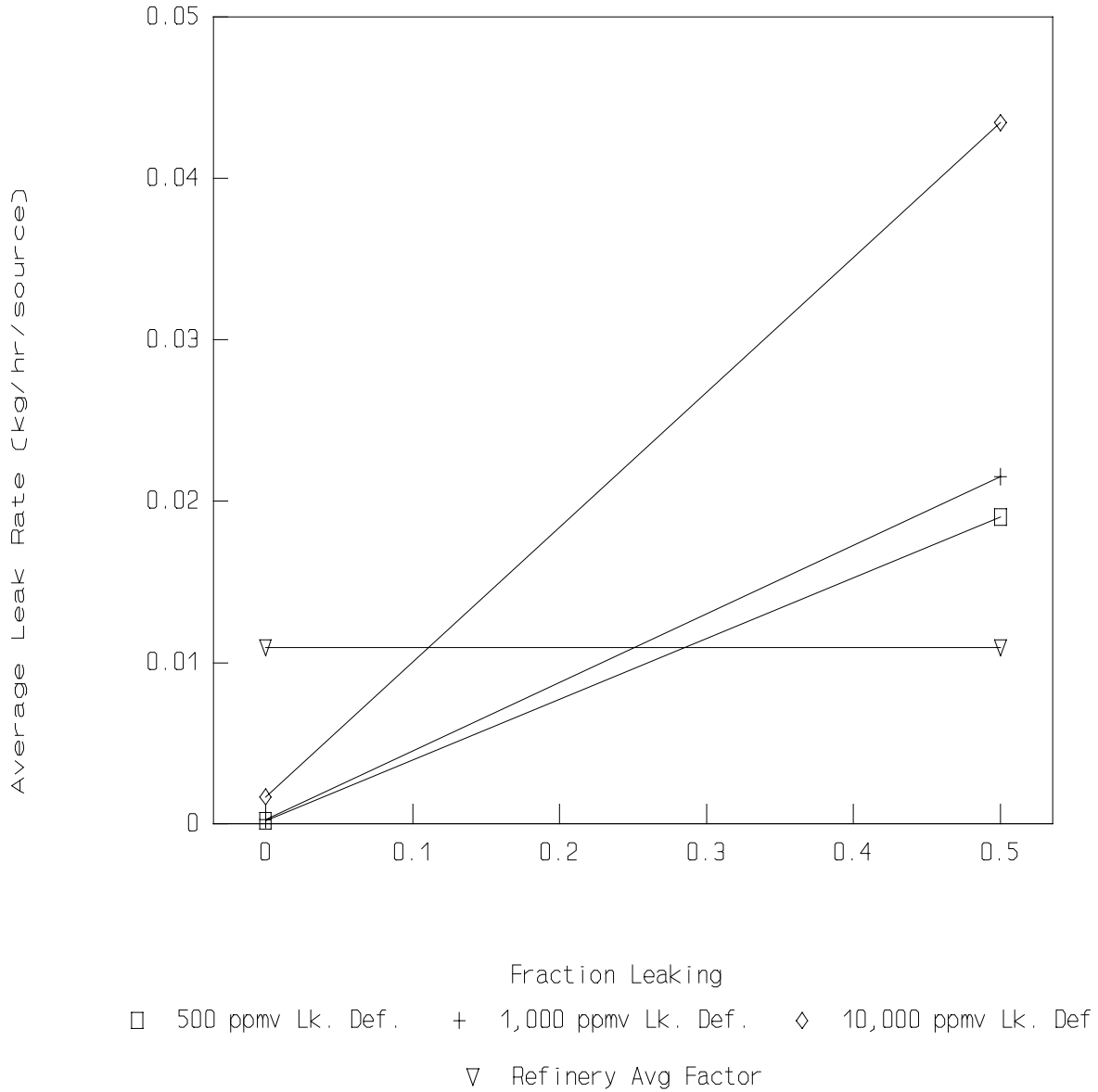

Figure 5-6. Refinery Light Liquid Valve Average Leak Rate Versus Fraction Leaking at Several Leak Definitions

Refinery Light Liquid Pump Equations

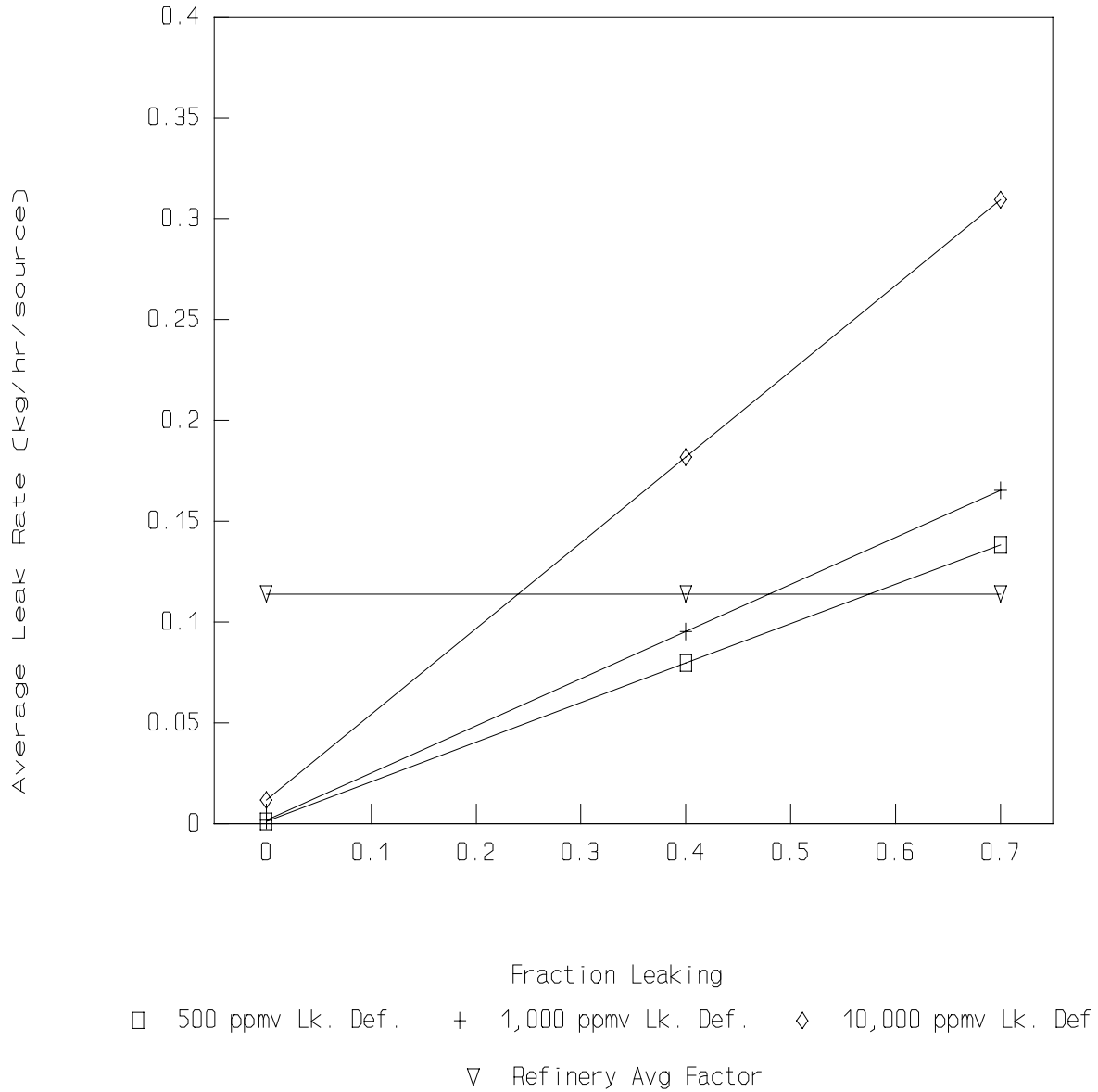

Figure 5-7. Refinery Light Liquid Pump Average Leak Rate Versus Fraction Leaking at Several Leak Definitions

Refinery Connector Equations

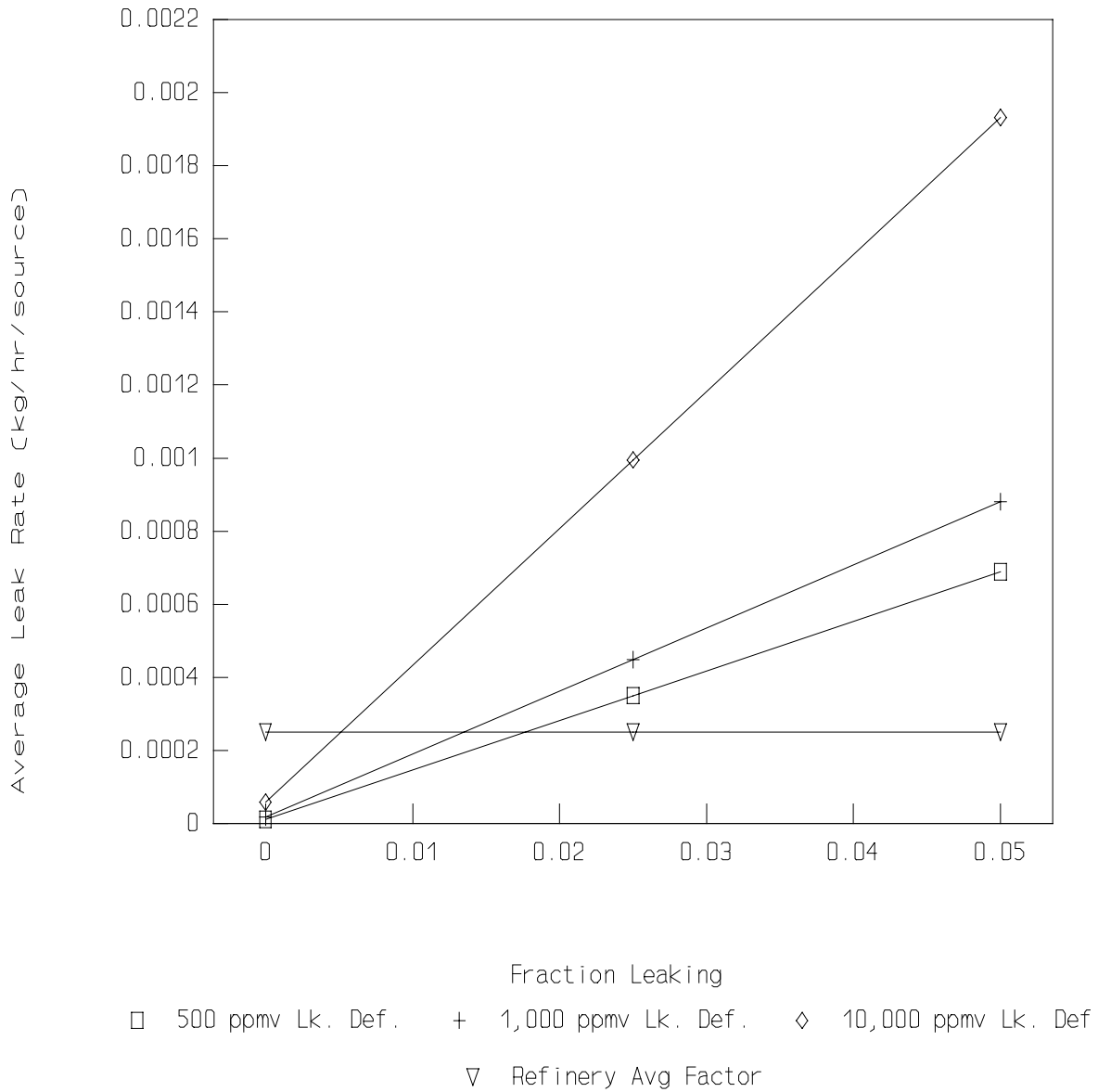
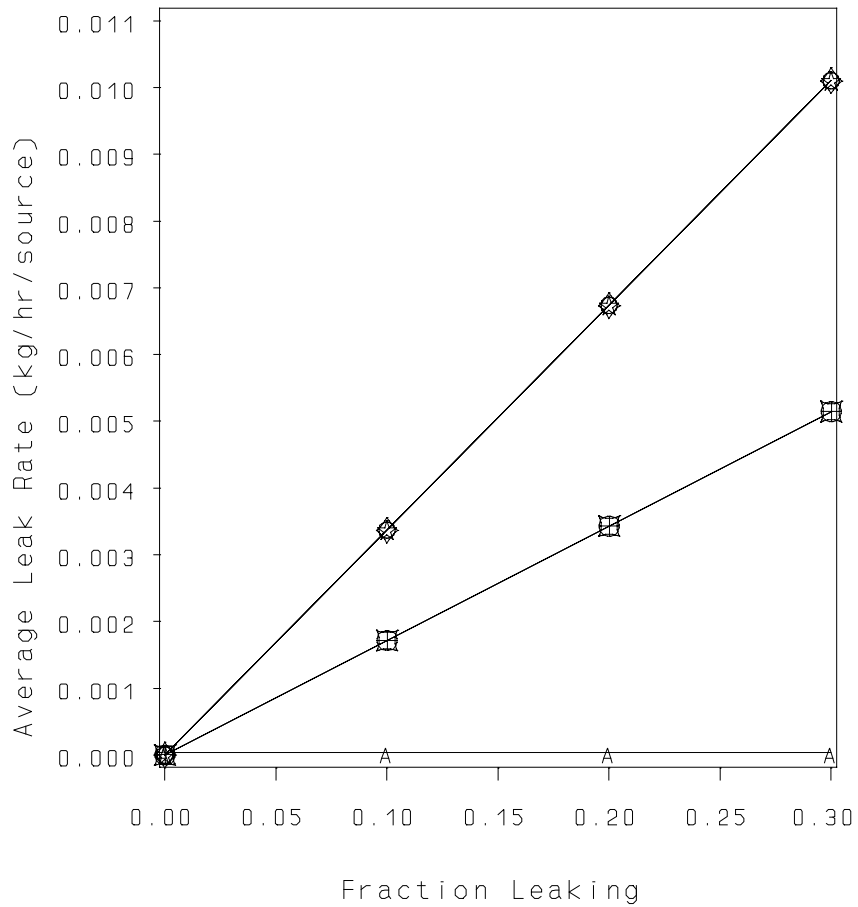

Figure 5-8. Refinery Connector Average Leak Rate Versus Fraction Leaking at Several Leak Definitions

Average Leak Rate Curves Marketing Terminals – Gas Fittings



Leak Definition:

- | | |
|-----------------|------------------|
| ⊕⊕⊕ 500 ppmv | ⊞⊞⊞ 1,000 ppmv |
| ◇◇◇ 2,000 ppmv | ⊖⊖⊖ 5,000 ppmv |
| ☆☆☆ 10,000 ppmv | A-A-A Avg Factor |

Figure 5-9. Marketing Terminal Gas Fittings Average Leak Rate Versus Fraction Leaking at Several Leak Definitions

Average Leak Rate Curves

Marketing Terminals – Light Liquid Fittings

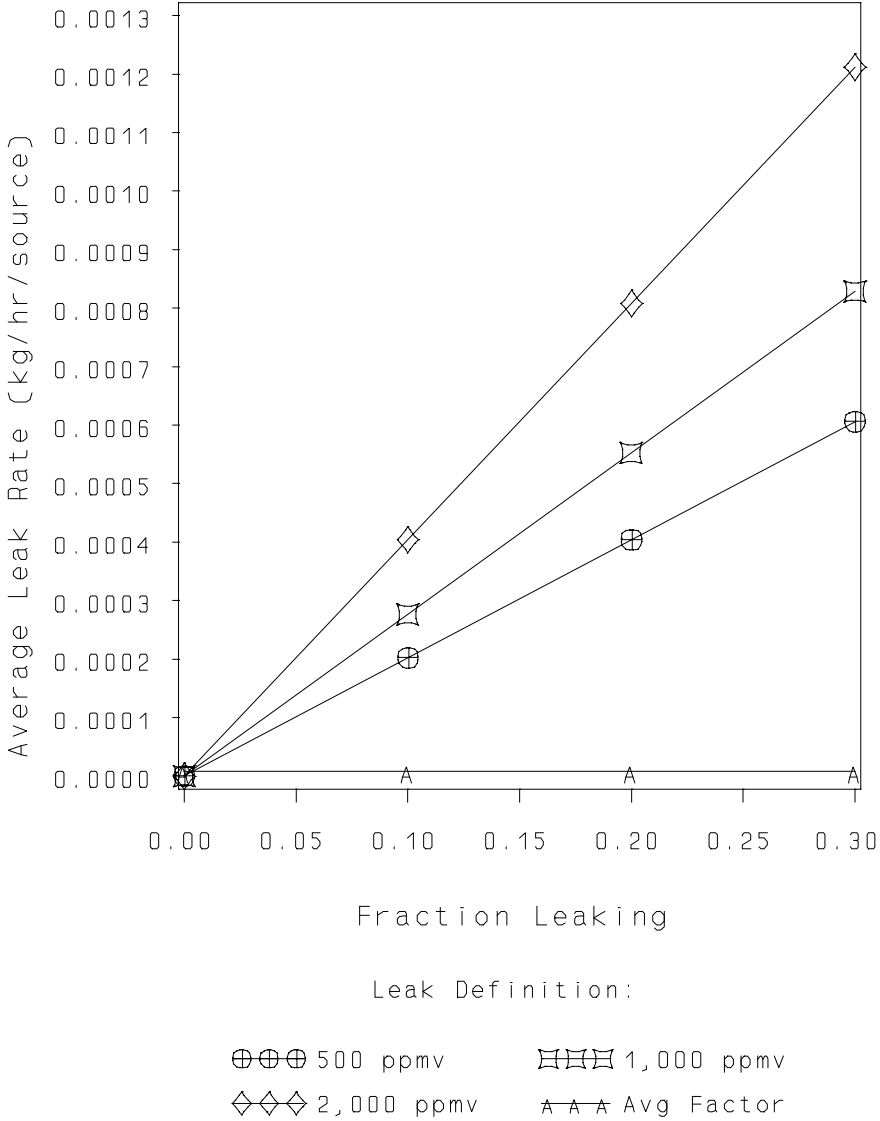

Figure 5-10. Marketing Terminal Light Liquid Fittings Average Leak Rate Versus Fraction Leaking at Several Leak Definitions

Average Leak Rate Curves Marketing Terminals – Gas Others

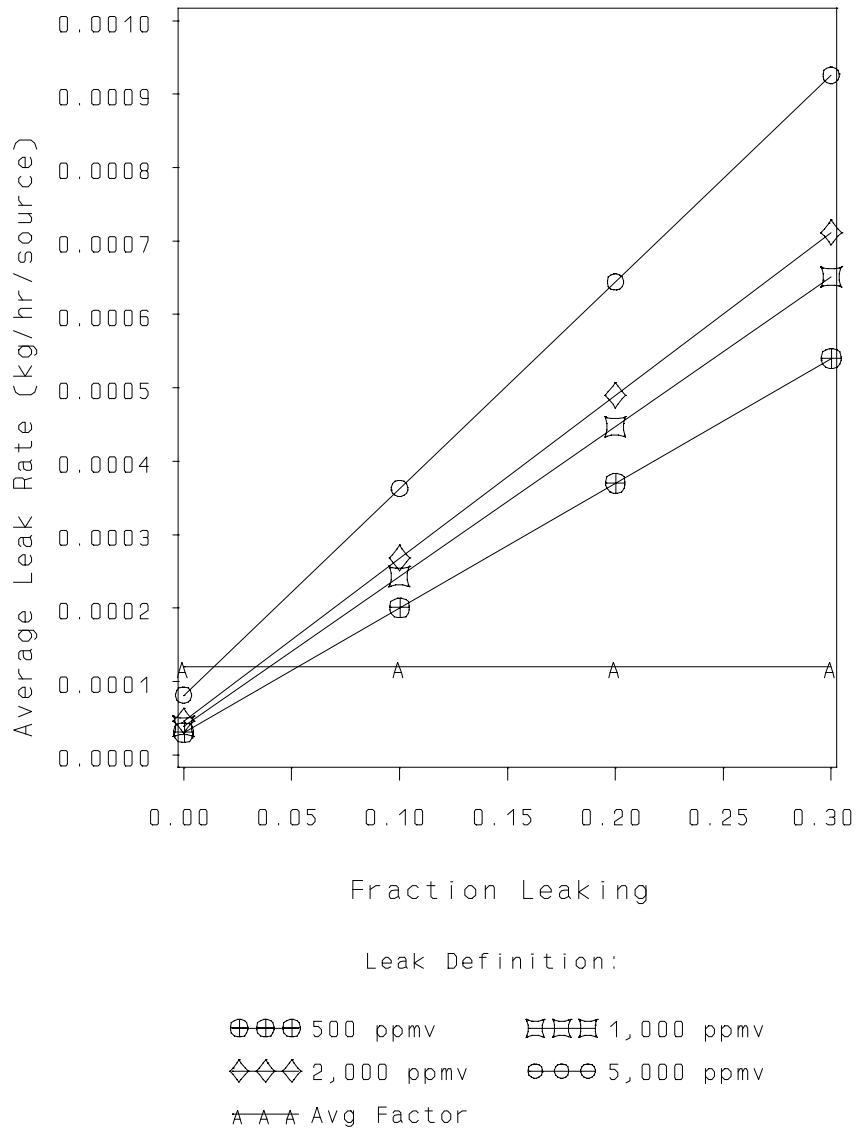
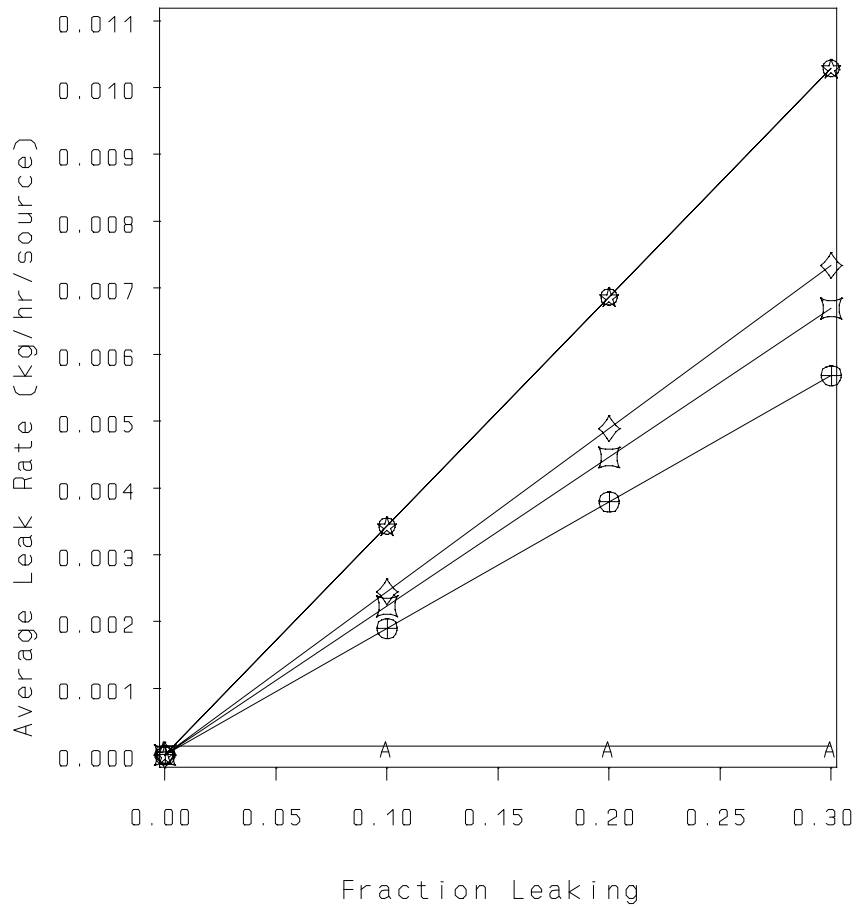

Figure 5-11. Marketing Terminal Gas Others Average Leak Rate Versus Fraction Leaking at Several Leak Definitions

Average Leak Rate Curves Marketing Terminals – Light Liquid Others



Leak Definition:

- | | |
|-----------------|----------------|
| ⊕⊕⊕ 500 ppmv | ⊞⊞⊞ 1,000 ppmv |
| ◇◇◇ 2,000 ppmv | ⊖⊖⊖ 5,000 ppmv |
| ☆☆☆ 10,000 ppmv | ▲▲▲ Avg Factor |

Figure 5-12. Marketing Terminal Light Liquid Others Average Leak Rate Versus Fraction Leaking at Several Leak Definitions

Average Leak Rate Curves

Marketing Terminals – Light Liquid Pumps

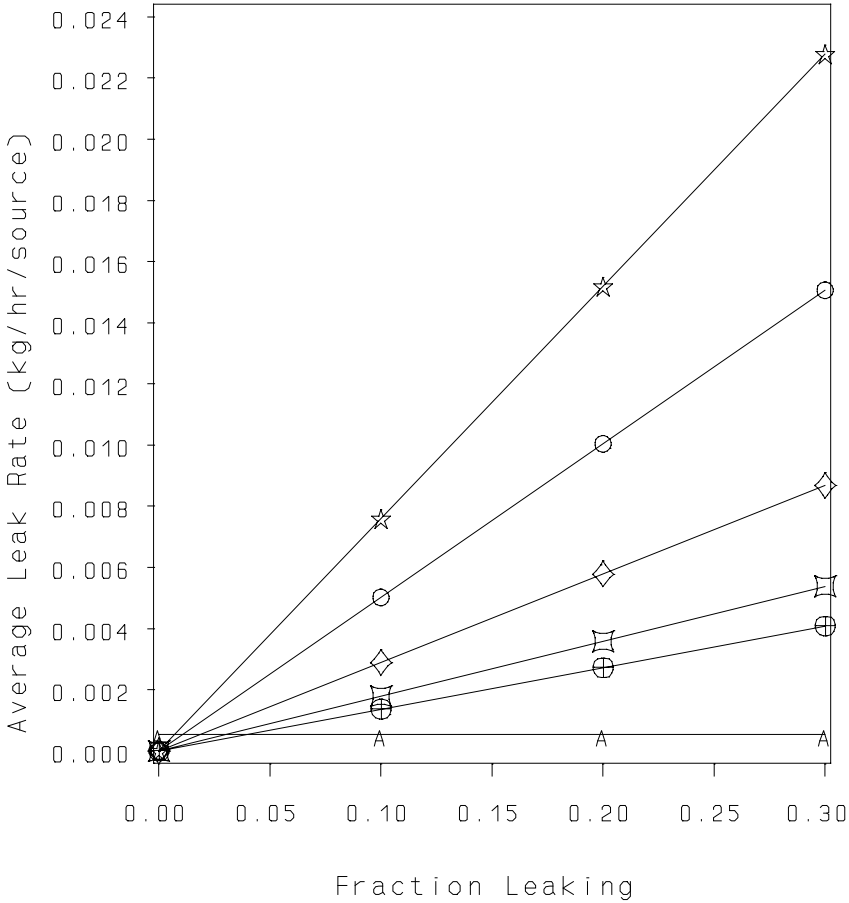

Leak Definition:

- ⊕⊕⊕ 500 ppmv ⊞⊞⊞ 1,000 ppmv
- ◇◇◇ 2,000 ppmv ⊖⊖⊖ 5,000 ppmv
- ☆☆☆ 10,000 ppmv A-A-A Avg Factor

Figure 5-13. Marketing Terminal Light Liquid Pumps Average Leak Rate Versus Fraction Leaking at Several Leak Definitions

Average Leak Rate Curves Marketing Terminals – Gas Valves

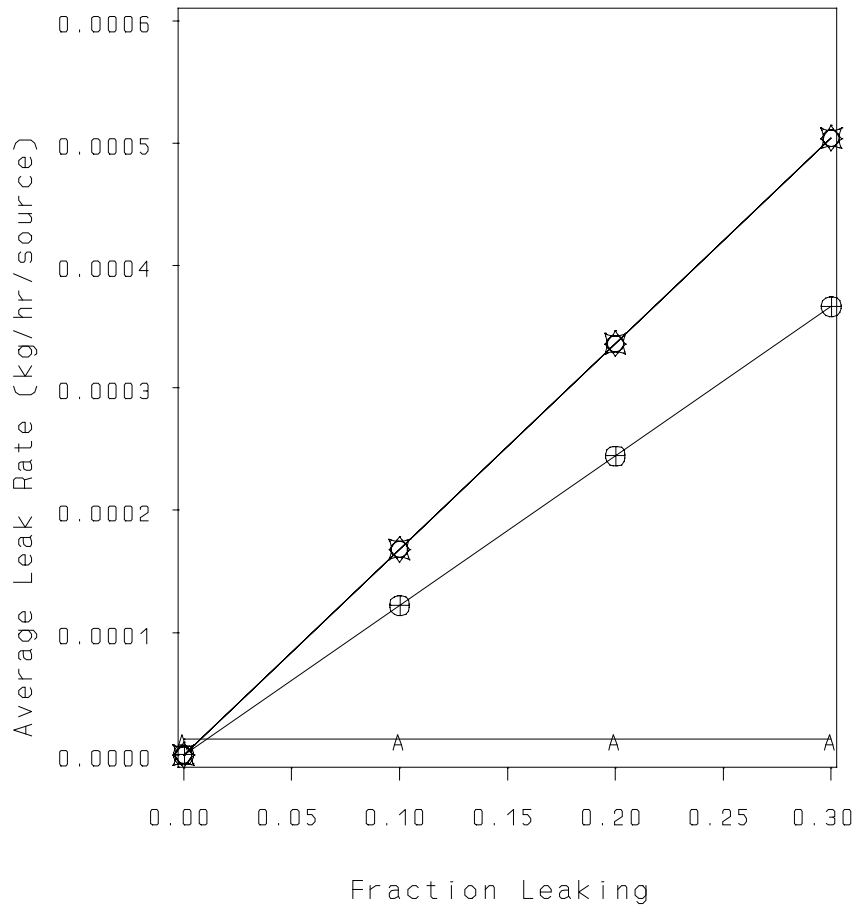

Leak Definition:

- ⊕⊕⊕ 500 ppmv ⊠⊠⊠ 1,000 ppmv
- ◇◇◇ 2,000 ppmv ⊖⊖⊖ 5,000 ppmv
- ▲▲▲ Avg Factor

Figure 5-14. Marketing Terminal Gas Valves Average Leak Rate Versus Fraction Leaking at Several Leak Definitions

Average Leak Rate Curves

Marketing Terminals – Light Liquid Valves

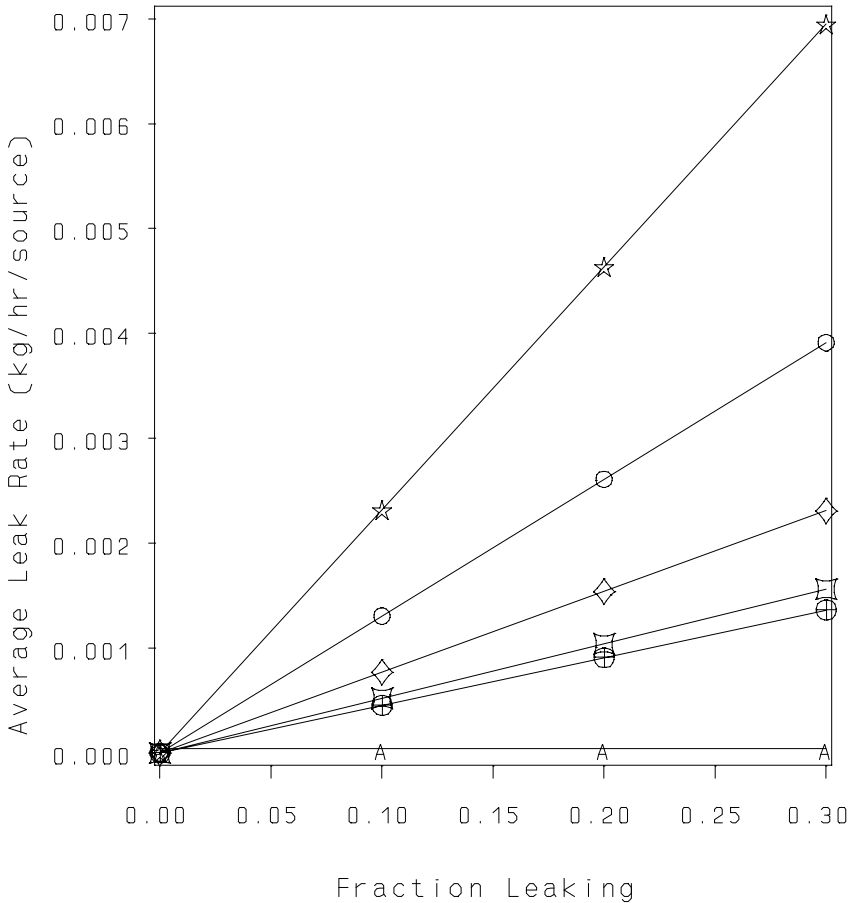

Leak Definition:

- ⊕⊕⊕ 500 ppmv ⊞⊞⊞ 1,000 ppmv
- ◇◇◇ 2,000 ppmv ⊖⊖⊖ 5,000 ppmv
- ☆☆☆ 10,000 ppmv ▲▲▲ Avg Factor

Figure 5-15. Marketing Terminal Liquid Light Valves Average Leak Rate Versus Fraction Leaking at Several Leak Definitions

marketing terminal process units. Figures 5-16 through 5-34 present mass emission rate as a function of leak frequency for connectors, flanges, open-ended lines, others, pumps, and valves at oil and gas production operations. Using these figures, for a given leak definition, the leak rate before and after the LDAR program is implemented, along with the corresponding control effectiveness, can be determined by plotting the initial and final leak frequency on these graphs. Tables 5-4, 5-5, 5-6, and 5-7 present equations for the lines in each of the SOCFI, refinery, marketing terminal, and oil and gas production operations, and graphs, respectively. Appendix G describes the approach that was used to develop the equations.

Figure 5-35 provides guidance on how to determine the initial and final leak frequencies. This figure is a simplified graphical presentation on how the leak frequency will change after an LDAR program is implemented. When generating the figure, it was assumed that all equipment pieces are monitored at the same time. Each occurrence of equipment monitoring is referred to as a "monitoring cycle," and it is assumed that equal time periods lapse between monitoring cycles.

From figure 5-35, it can be seen that there is an immediate reduction in leak frequency after the LDAR program is implemented, and then the leak frequency will oscillate over monitoring cycles. This oscillation occurs because between monitoring cycles a certain percentage of previously non-leaking equipment will begin to leak. There are four key points on the graph presented in figure 5-35. These key points are:

- Point X - initial leak frequency;
- Point Y - leak frequency immediately after monitoring for and repairing leaking equipment (i.e., immediately after a monitoring cycle);
- Point Z - leak frequency immediately preceding a monitoring cycle; and
- Point F - average leak frequency between monitoring cycles (final leak frequency).

Average Leak Rate Curves Oil & Gas Production – Gas Connectors

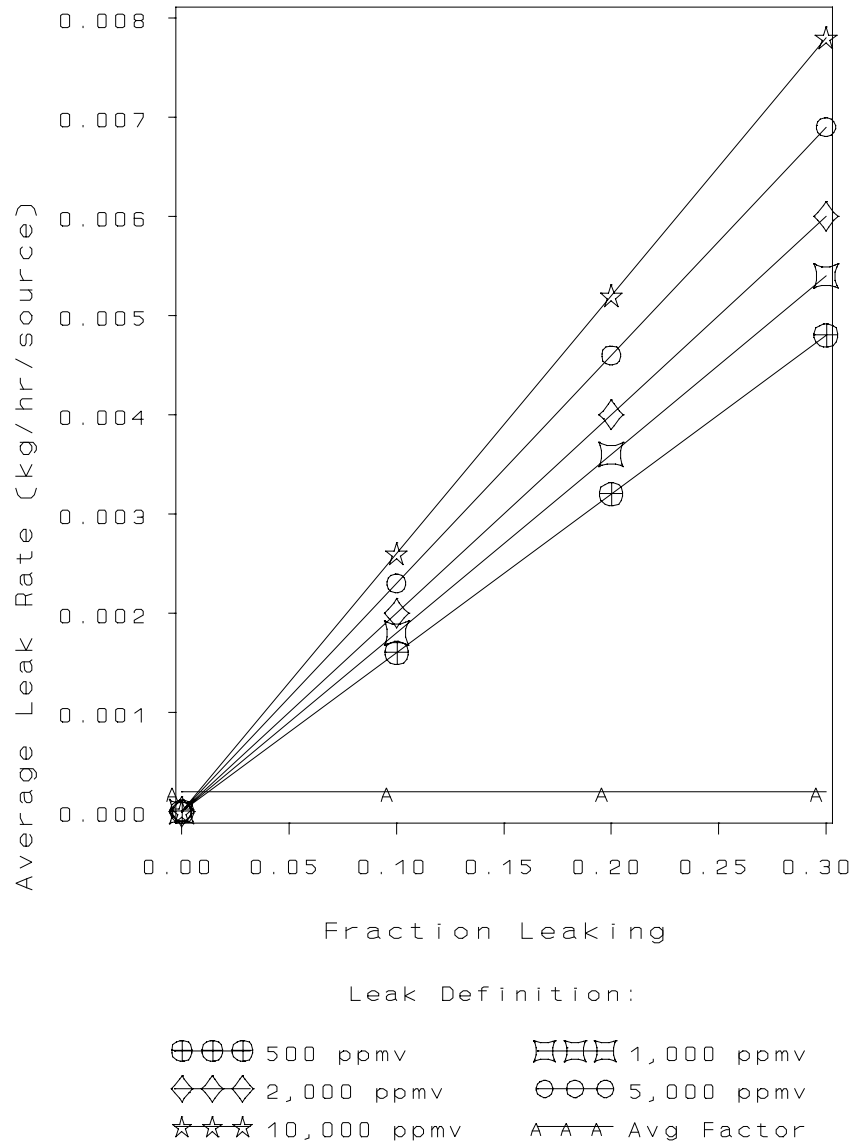

Figure 5-16. Oil and Gas Production Gas Connectors Average Leak Rate Versus Fraction Leaking at Several Leak Definitions

Average Leak Rate Curves Oil & Gas Production – Light Oil Connectors

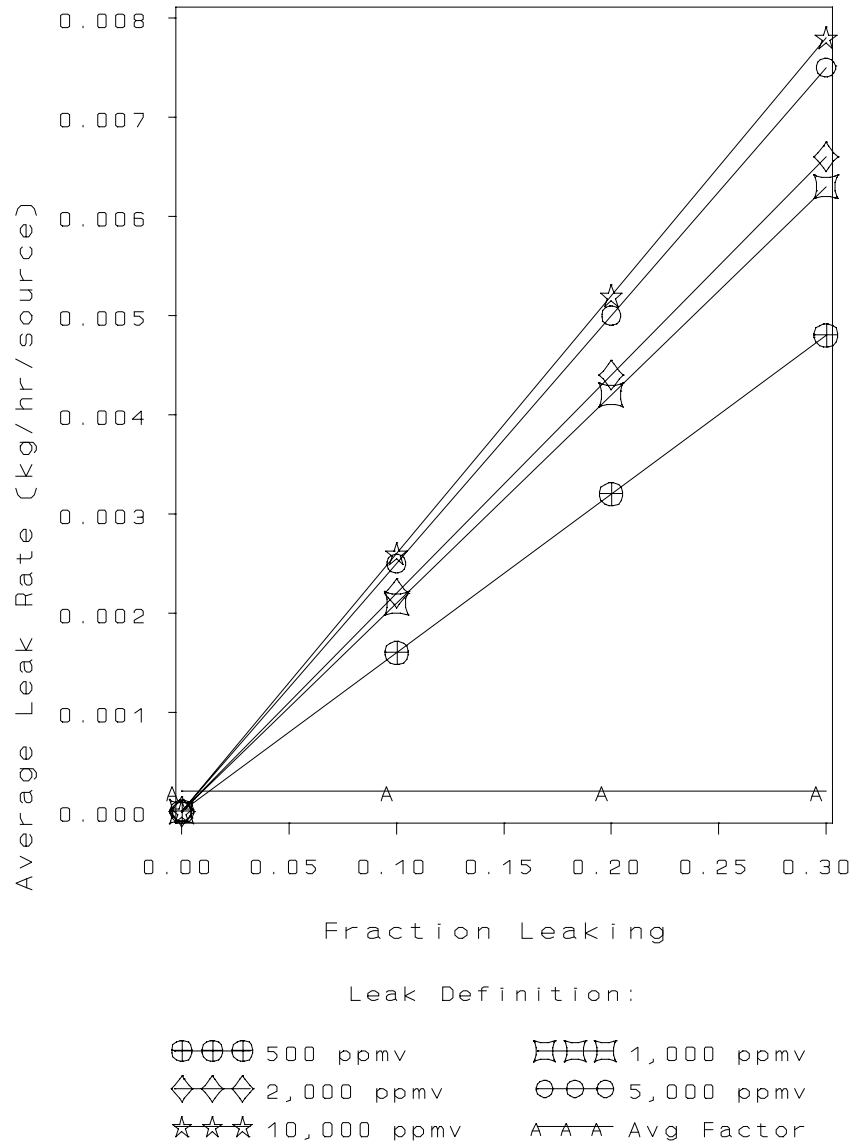

Figure 5-17. Oil and Gas Production Light Oil Connectors Average Leak Rate Versus Fraction Leaking at Several Leak Definitions

Average Leak Rate Curves Oil & Gas Production – Water/Oil Connectors

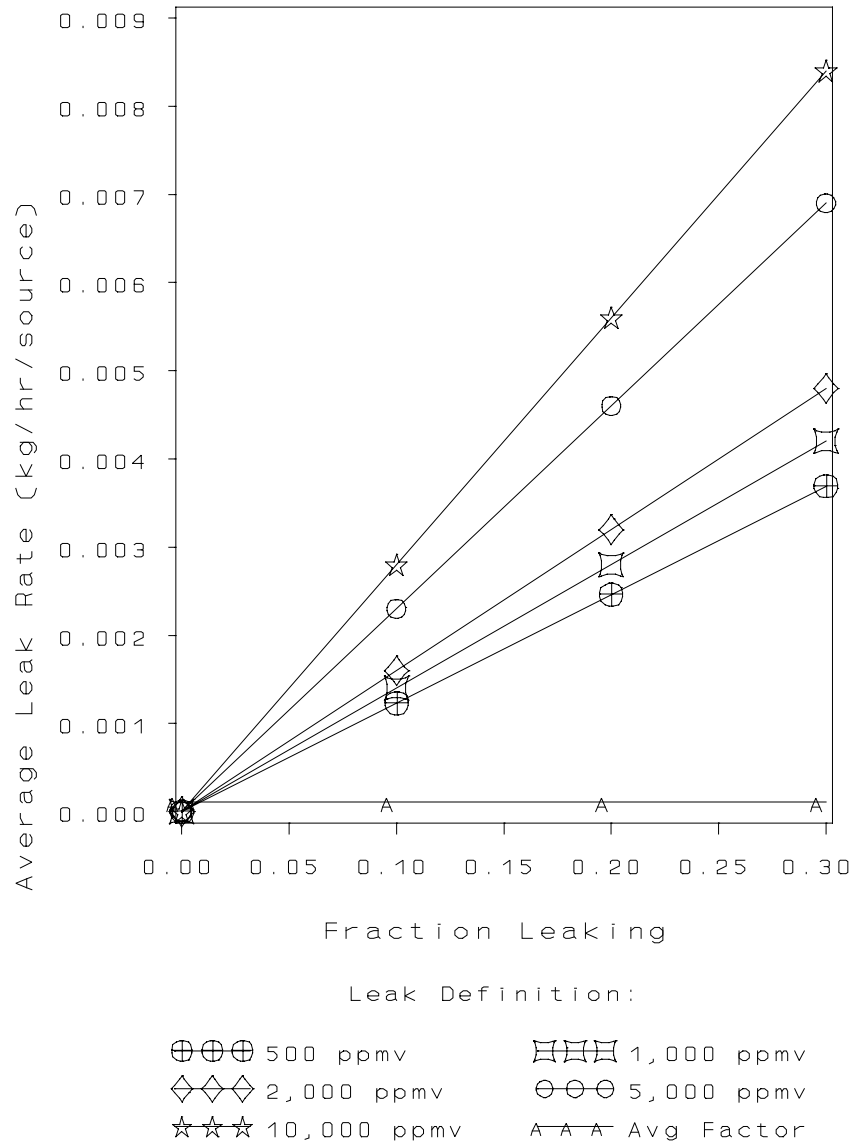

Figure 5-18. Oil and Gas Production Water/Oil Connectors Average Leak Rate Versus Fraction Leaking at Several Leak Definitions

Average Leak Rate Curves Oil & Gas Production – Gas Flanges

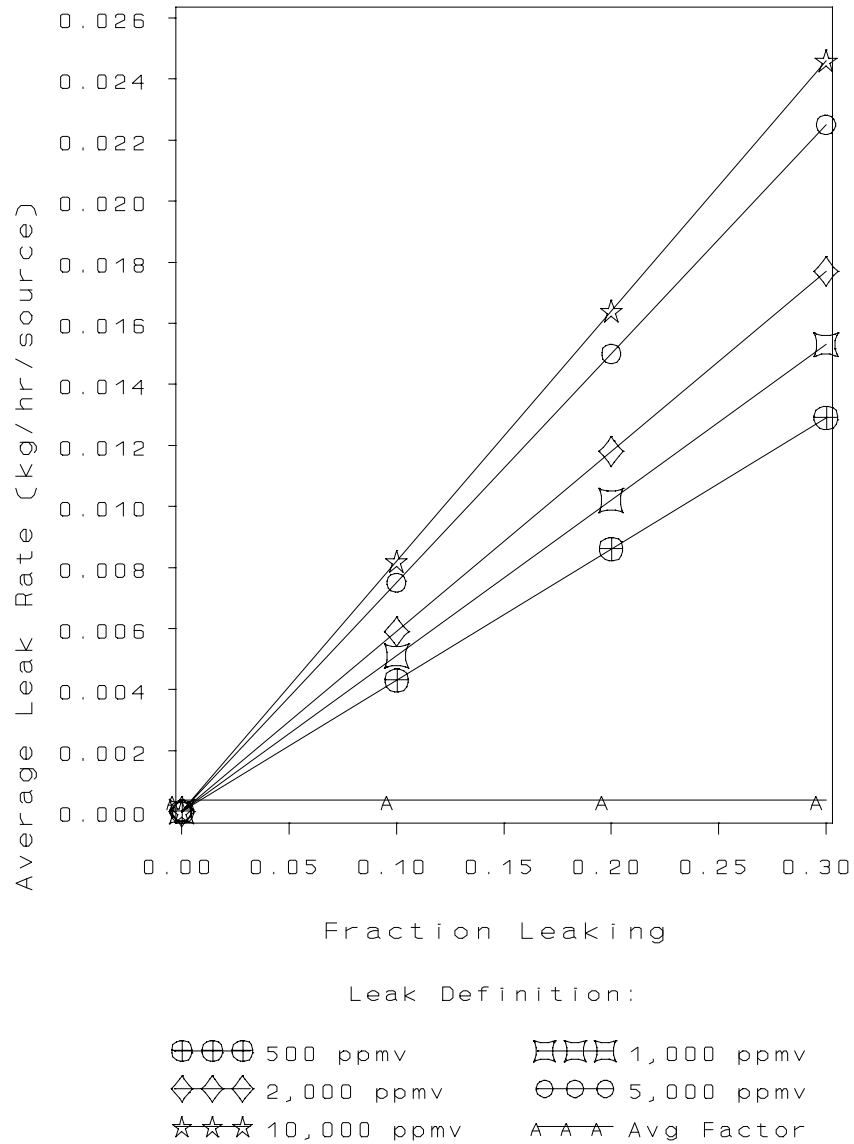

Figure 5-19. Oil and Gas Production Gas Flanges Average Leak Rate Versus Fraction Leaking at Several Leak Definitions

Average Leak Rate Curves Oil & Gas Production – Light Oil Flanges

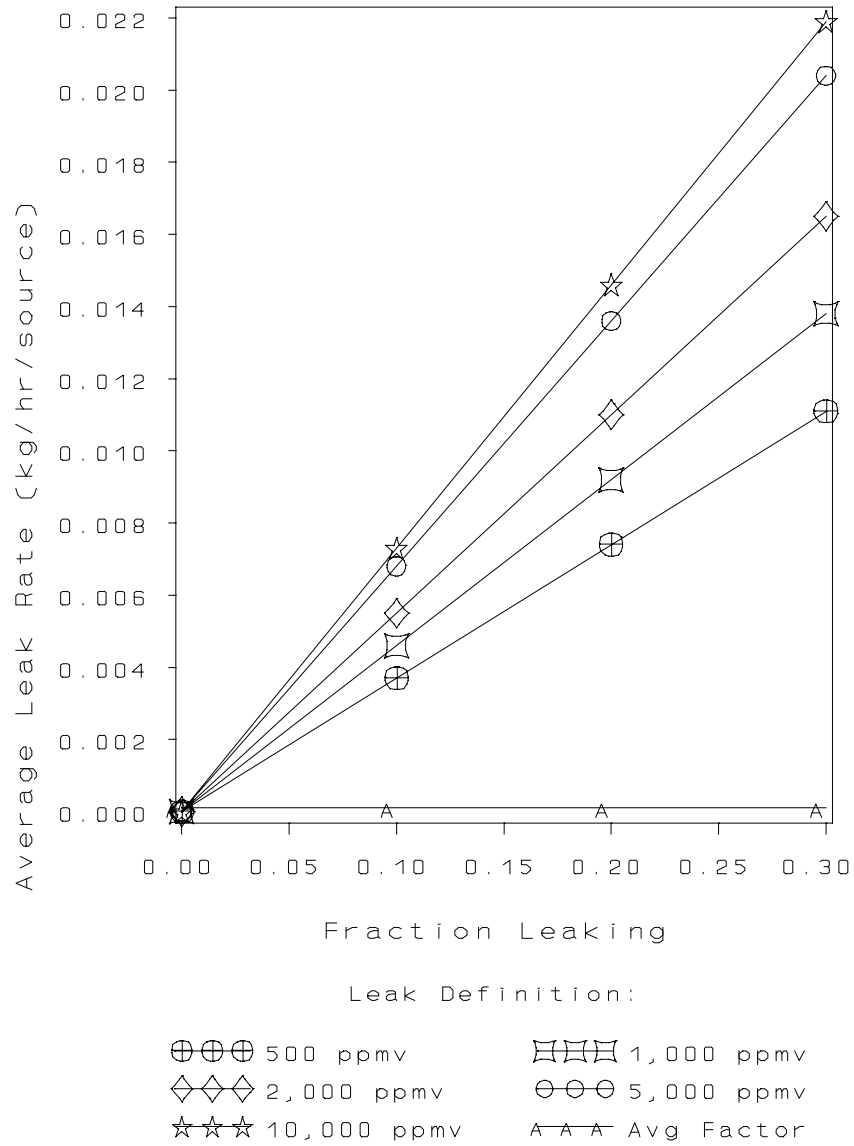

Figure 5-20. Oil and Gas Production Light Oil Flanges Average Leak Rate Versus Fraction Leaking at Several Leak Definitions

Average Leak Rate Curves

Oil & Gas Production – Gas Open-Ended Lines

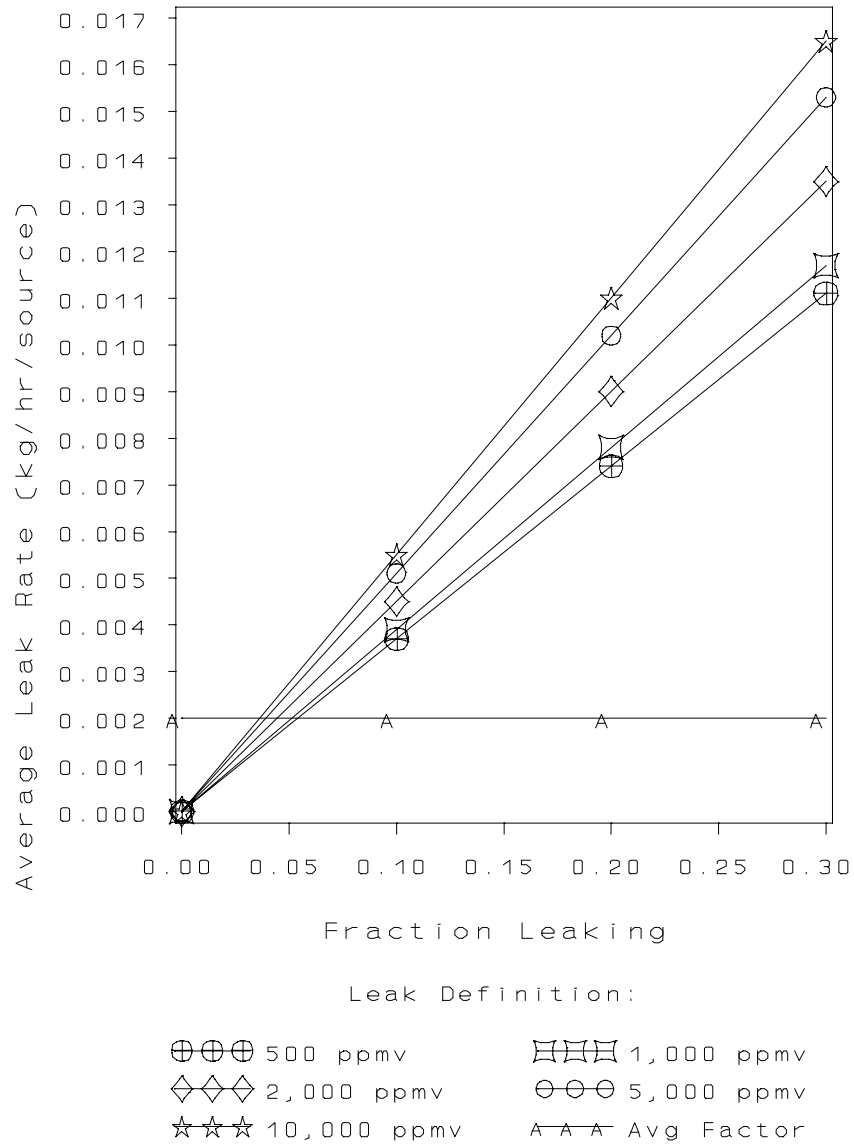

Figure 5-21. Oil and Gas Production Gas Open-Ended Lines Average Leak Rate Versus Fraction Leaking at Several Leak Definitions

Average Leak Rate Curves

Oil & Gas Production – Heavy Oil Open-Ended Lines

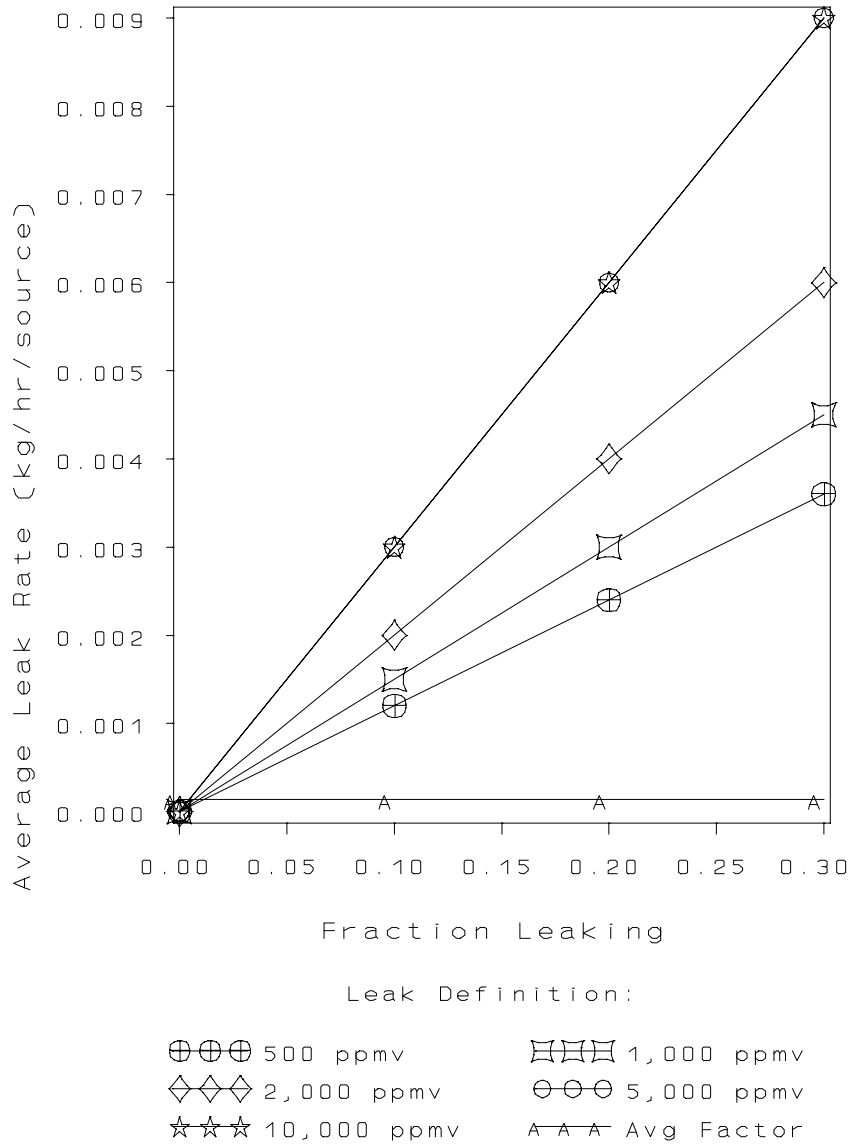

Figure 5-22. Oil and Gas Production Heavy Oil Open-Ended Lines Average Leak Rate Versus Fraction Leaking at Several Leak Definitions

Average Leak Rate Curves

Oil & Gas Production – Light Oil Open-Ended Lines

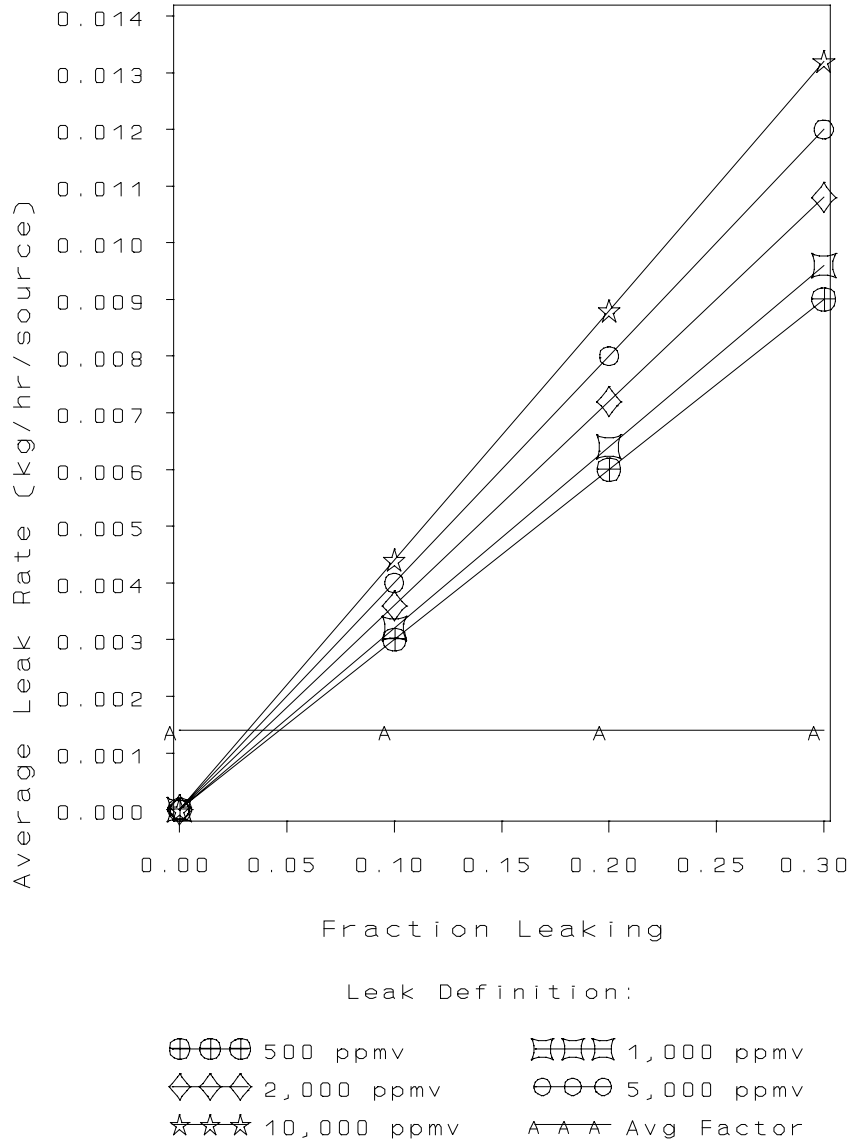

Figure 5-23. Oil and Gas Production Light Oil Open-Ended Lines Average Leak Rate Versus Fraction Leaking at Several Leak Definitions

Average Leak Rate Curves

Oil & Gas Production – Water/Oil Open-Ended Lines

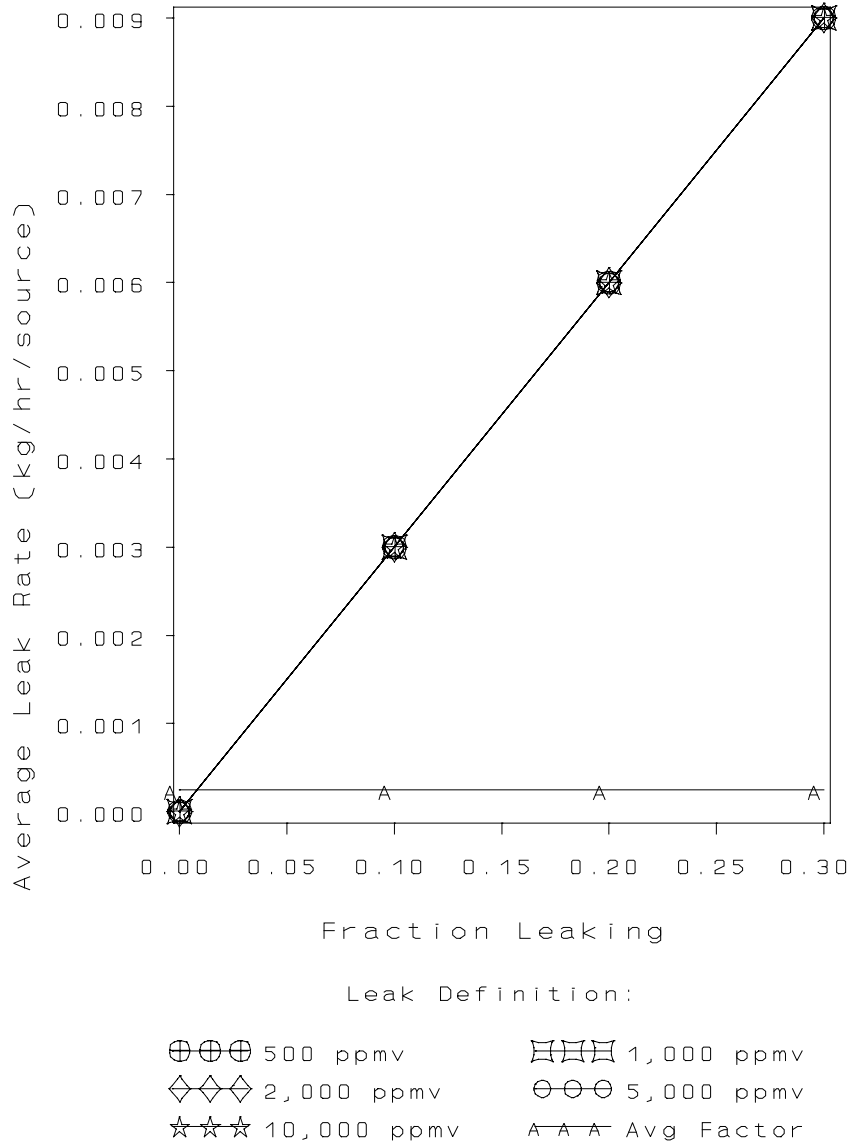

Figure 5-24. Oil and Gas Production Water/Oil Open-Ended Lines Average Leak Rate Versus Fraction Leaking at Several Leak Definitions

Average Leak Rate Curves Oil & Gas Production – Gas Other

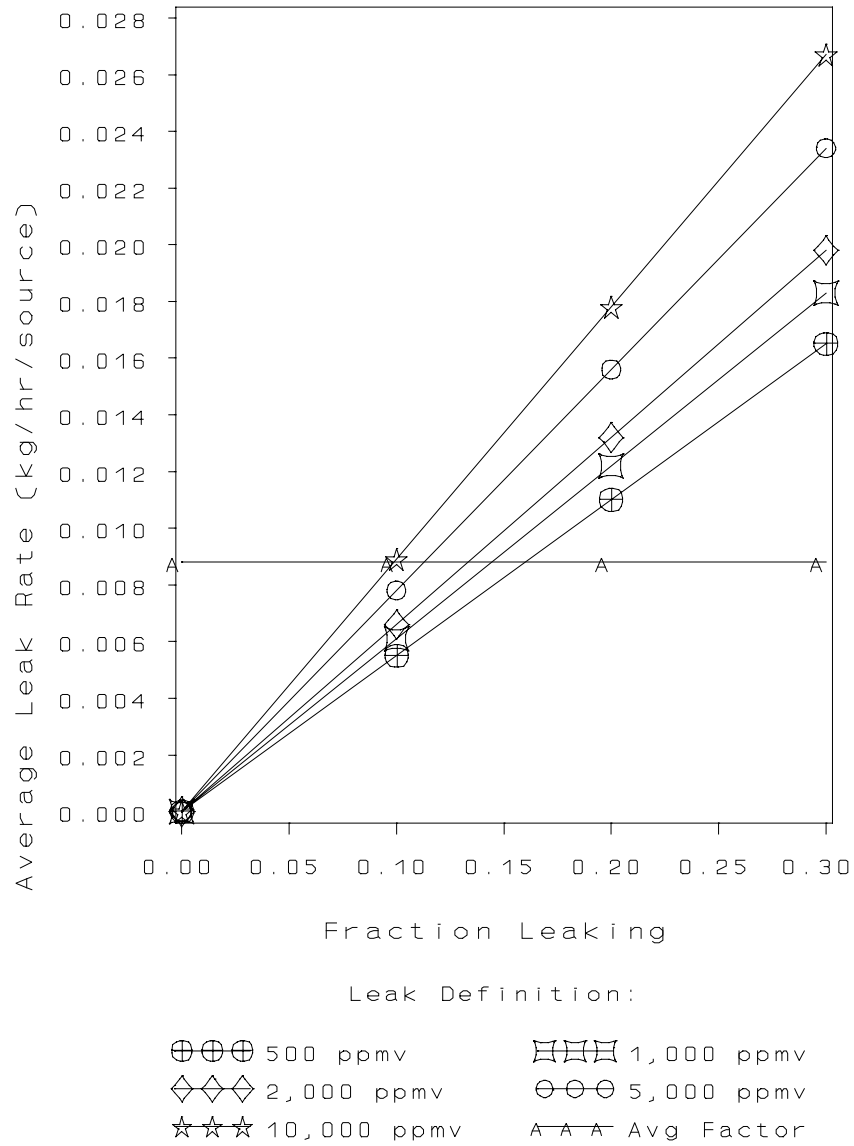

Figure 5-25. Oil and Gas Production Gas Other Average Leak Rate Versus Fraction Leaking at Several Leak Definitions

Average Leak Rate Curves Oil & Gas Production – Heavy Oil Other

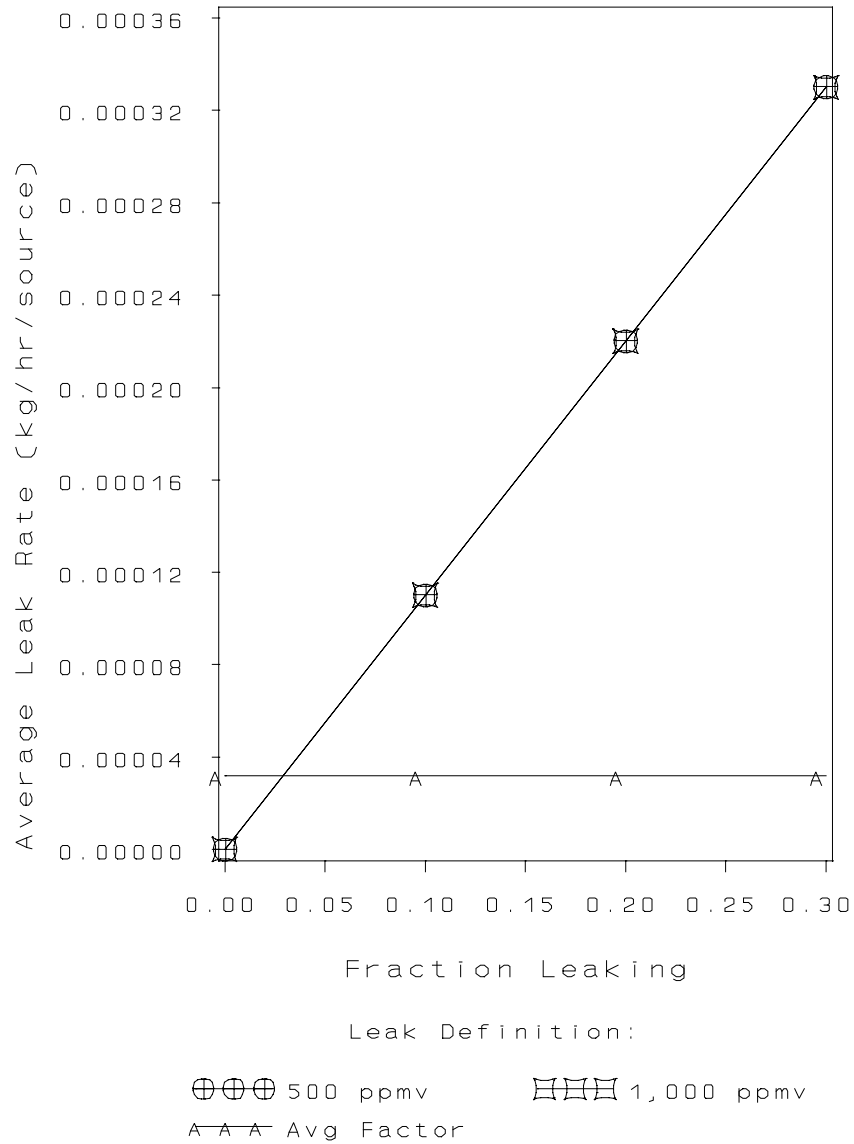

Figure 5-26. Oil and Gas Production Heavy Oil Other Average Leak Rate Versus Fraction Leaking at Several Leak Definitions

Average Leak Rate Curves Oil & Gas Production – Light Oil Other

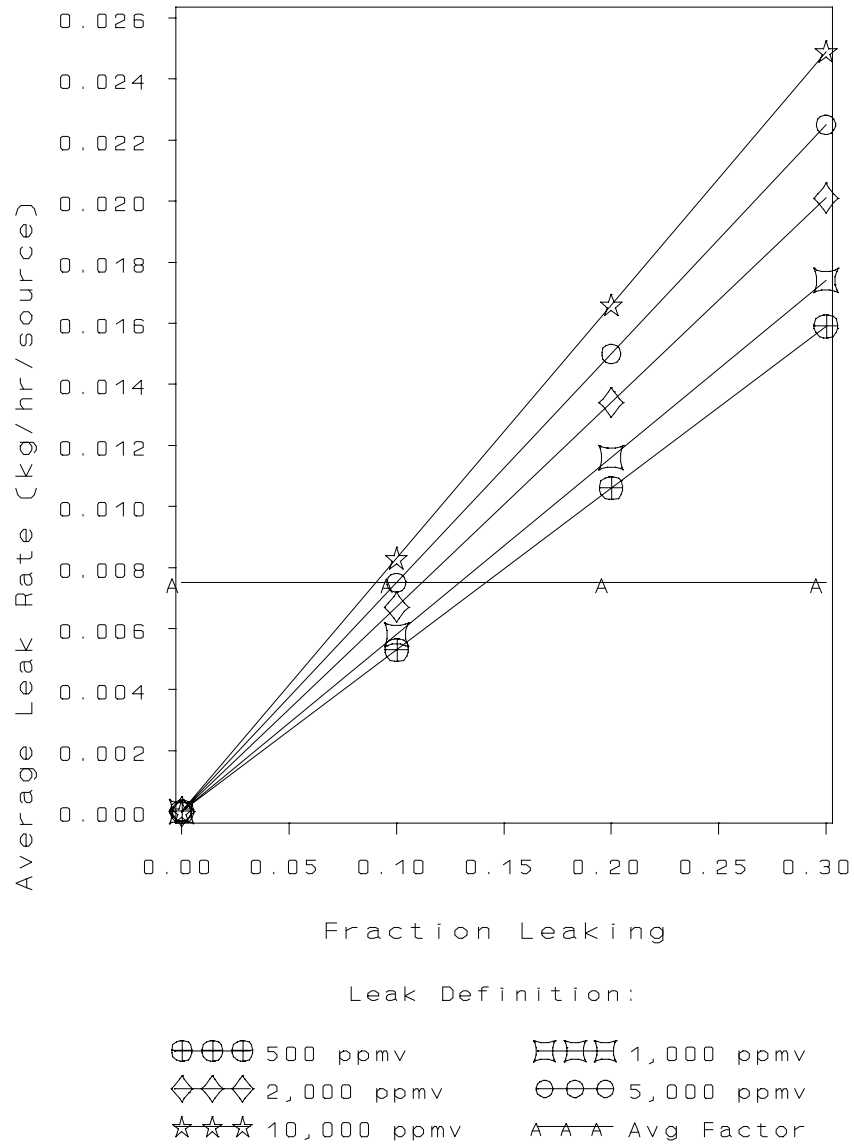

Figure 5-27. Oil and Gas Production Light Oil Other Average Leak Rate Versus Fraction Leaking at Several Leak Definitions

Average Leak Rate Curves Oil & Gas Production – Water/Oil Other

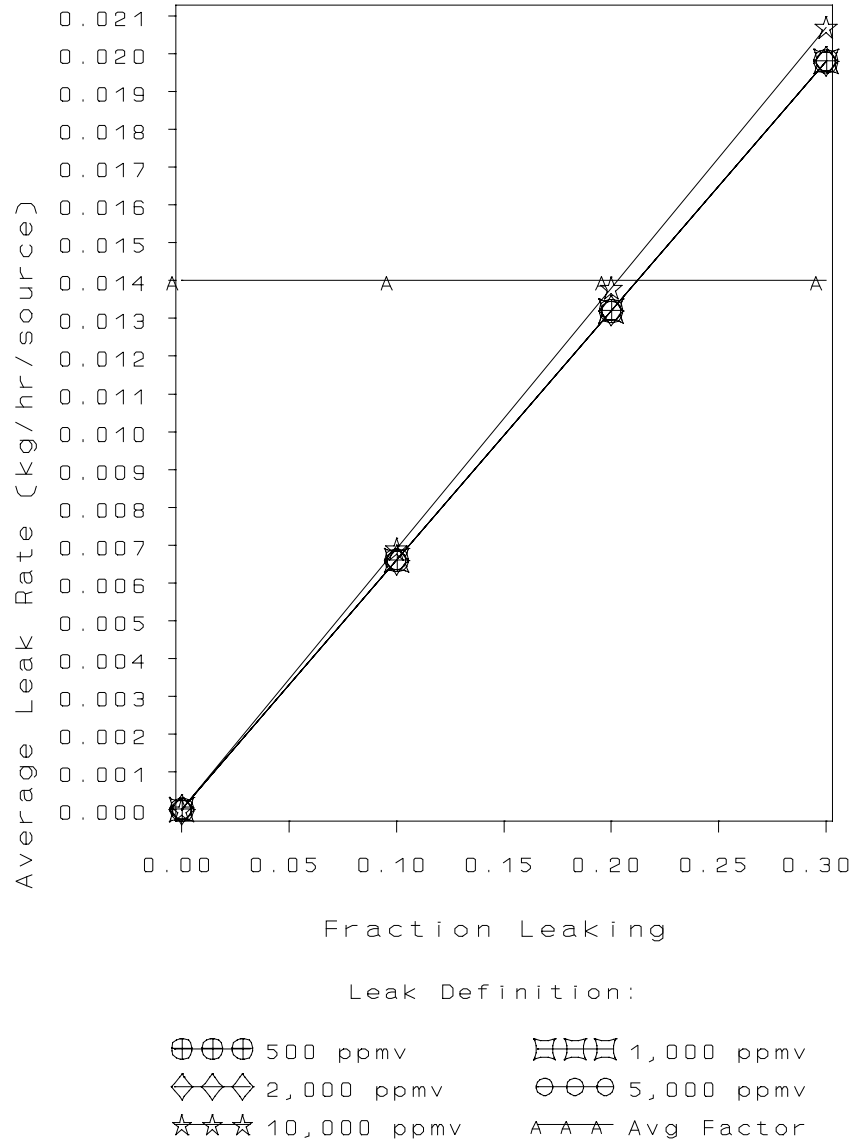

Figure 5-28. Oil and Gas Production Water/Oil Other Average Leak Rate Versus Fraction Leaking at Several Leak Definitions

Average Leak Rate Curves Oil & Gas Production – Gas Pumps

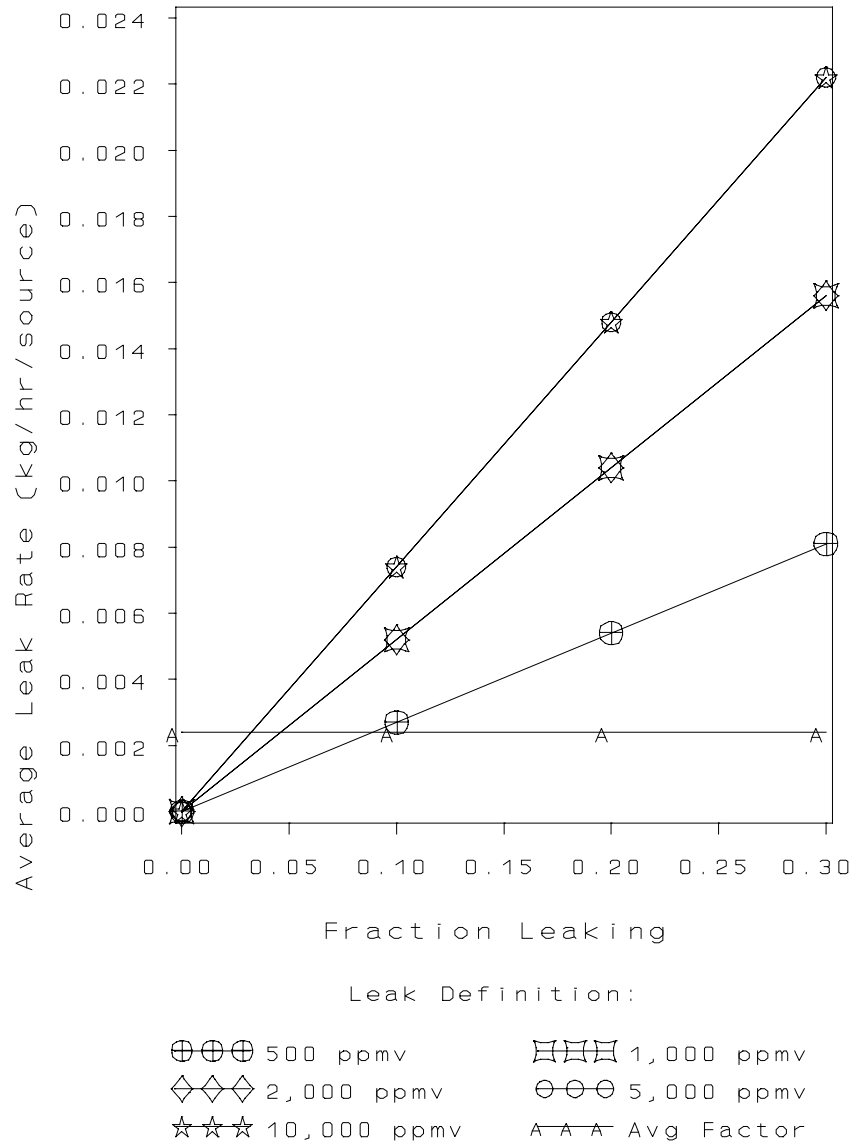

Figure 5-29. Oil and Gas Production Gas Pump Average Leak Rate Versus Fraction Leaking at Several Leak Definitions

Average Leak Rate Curves Oil & Gas Production – Light Oil Pumps

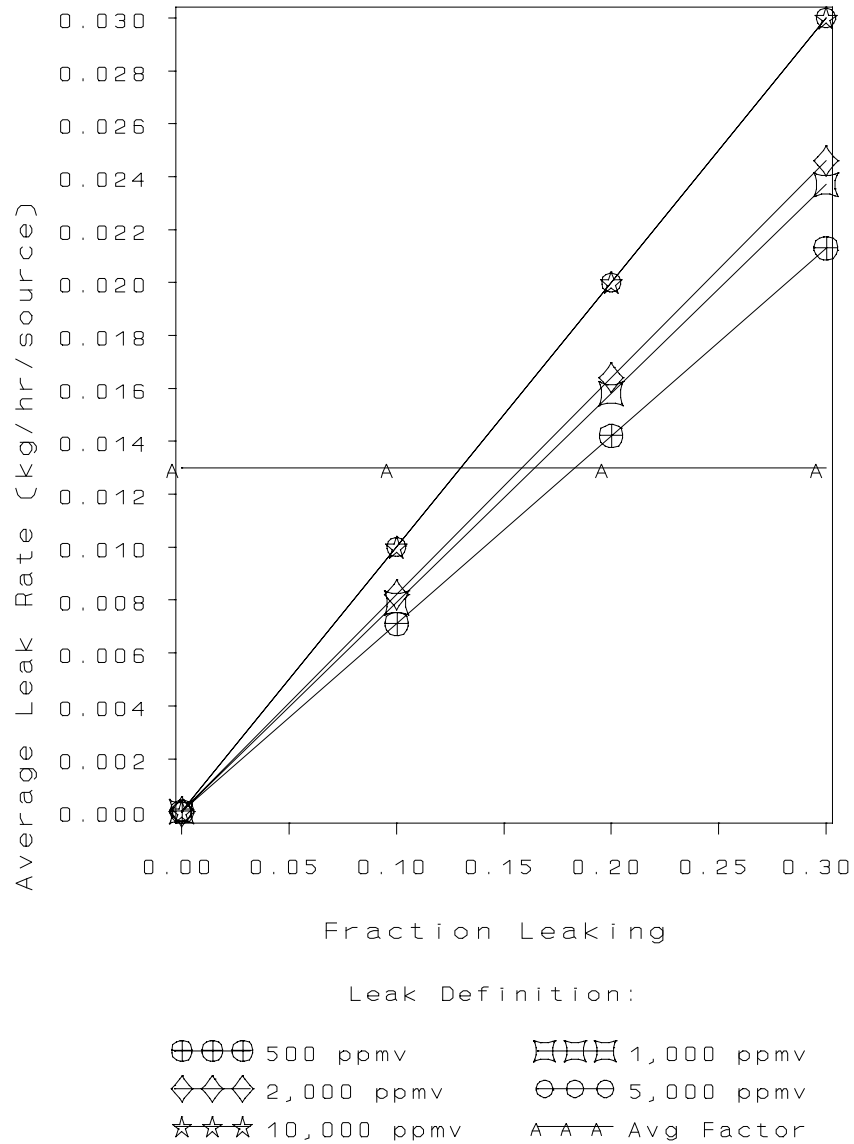

Figure 5-30. Oil and Gas Production Light Oil Pumps Average Leak Rate Versus Fraction Leaking at Several Leak Definitions

Average Leak Rate Curves Oil & Gas Production – Gas Valves

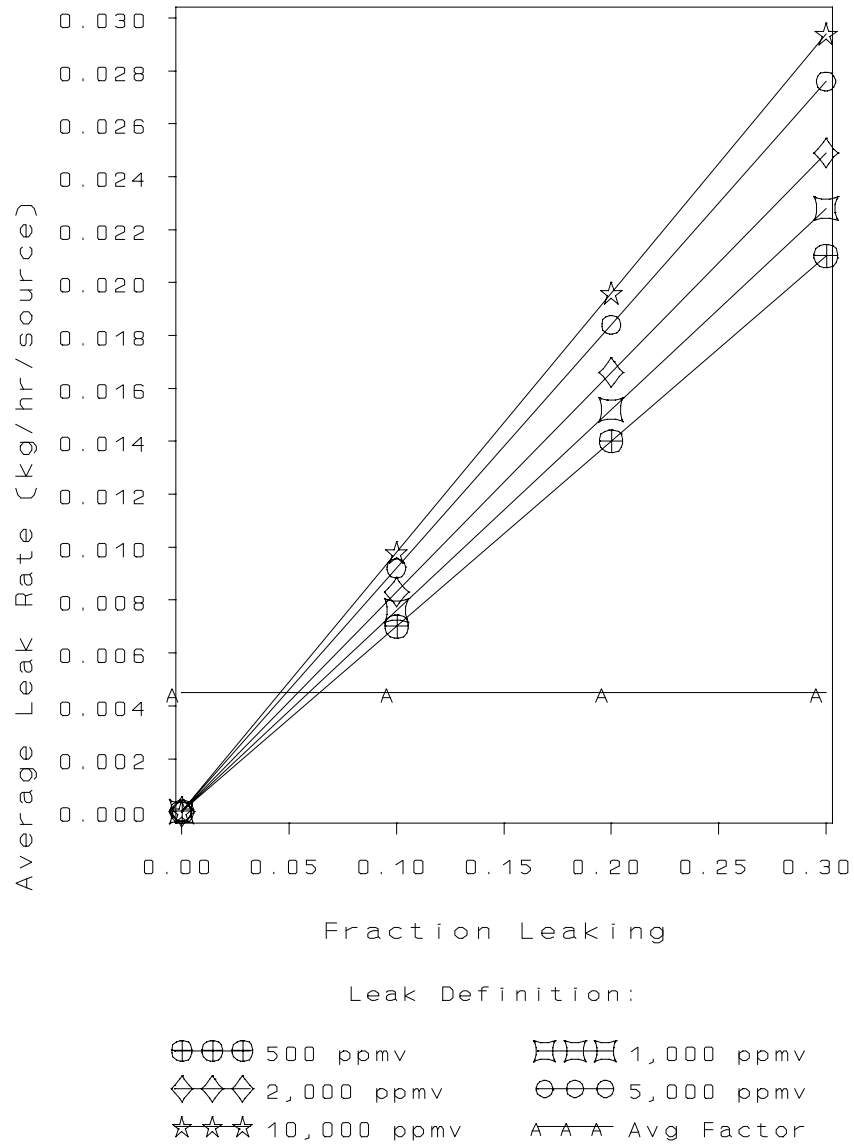

Figure 5-31. Oil and Gas Production Gas Valves Average Leak Rate Versus Fraction Leaking at Several Leak Definitions

Average Leak Rate Curves Oil & Gas Production – Heavy Oil Valves

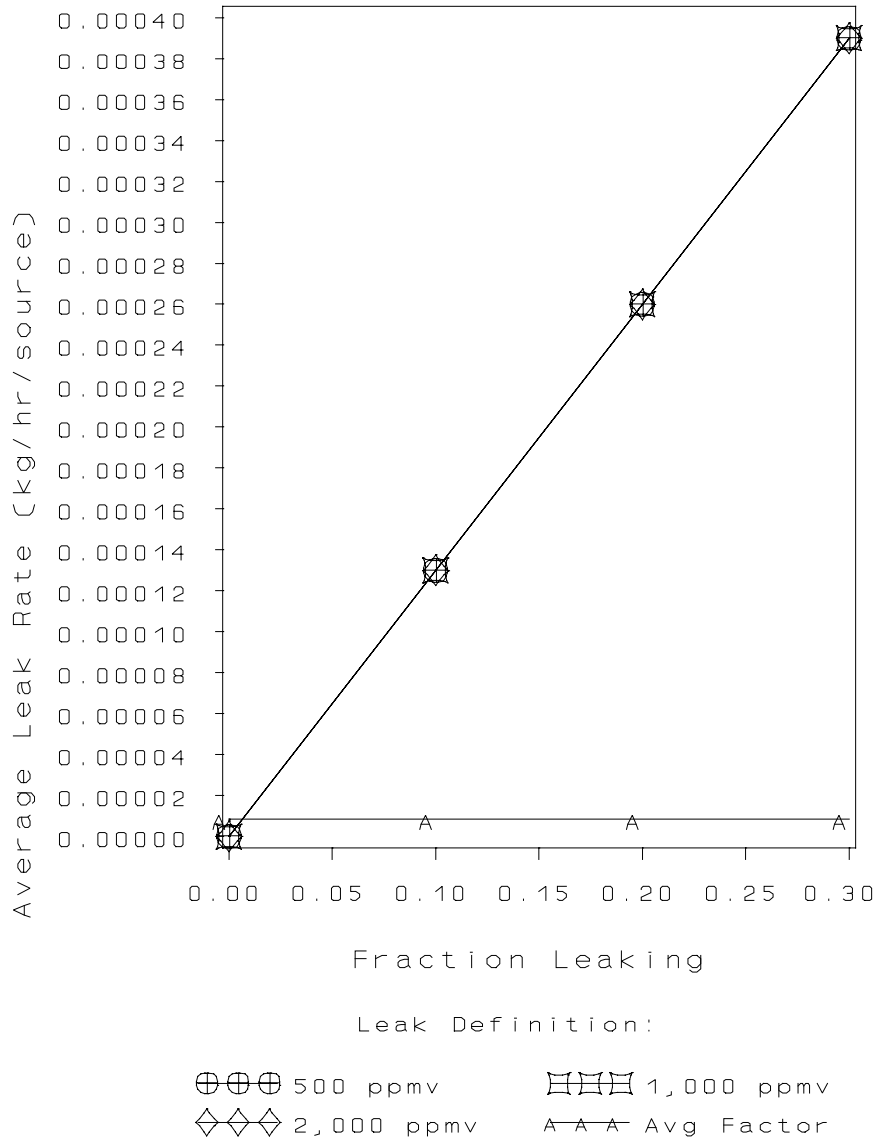

Figure 5-32. Oil and Gas Production Heavy Oil Valves Average Leak Rate Versus Fraction Leaking at Several Leak Definitions

Average Leak Rate Curves Oil & Gas Production – Light Oil Valves

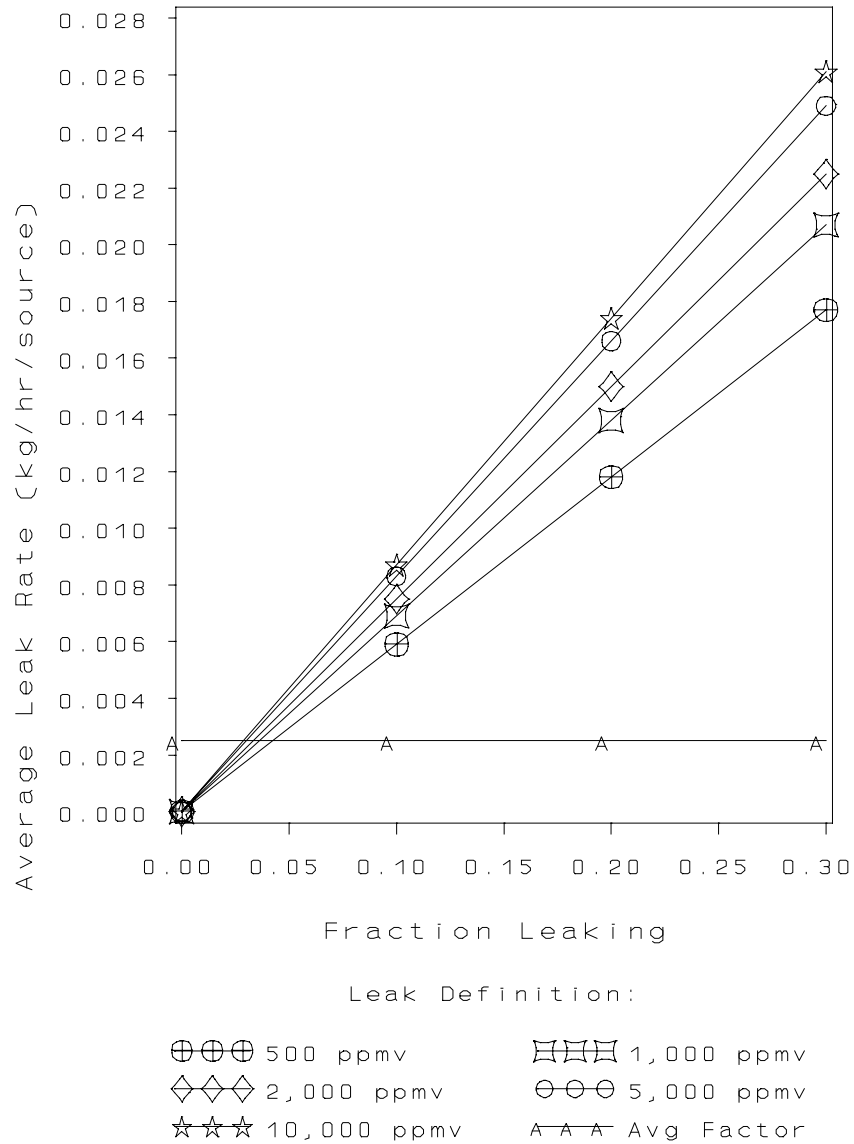

Figure 5-33. Oil and Gas Production Light Oil Valves Average Leak Rate Versus Fraction Leaking at Several Leak Definitions

Average Leak Rate Curves Oil & Gas Production – Water/Oil Valves

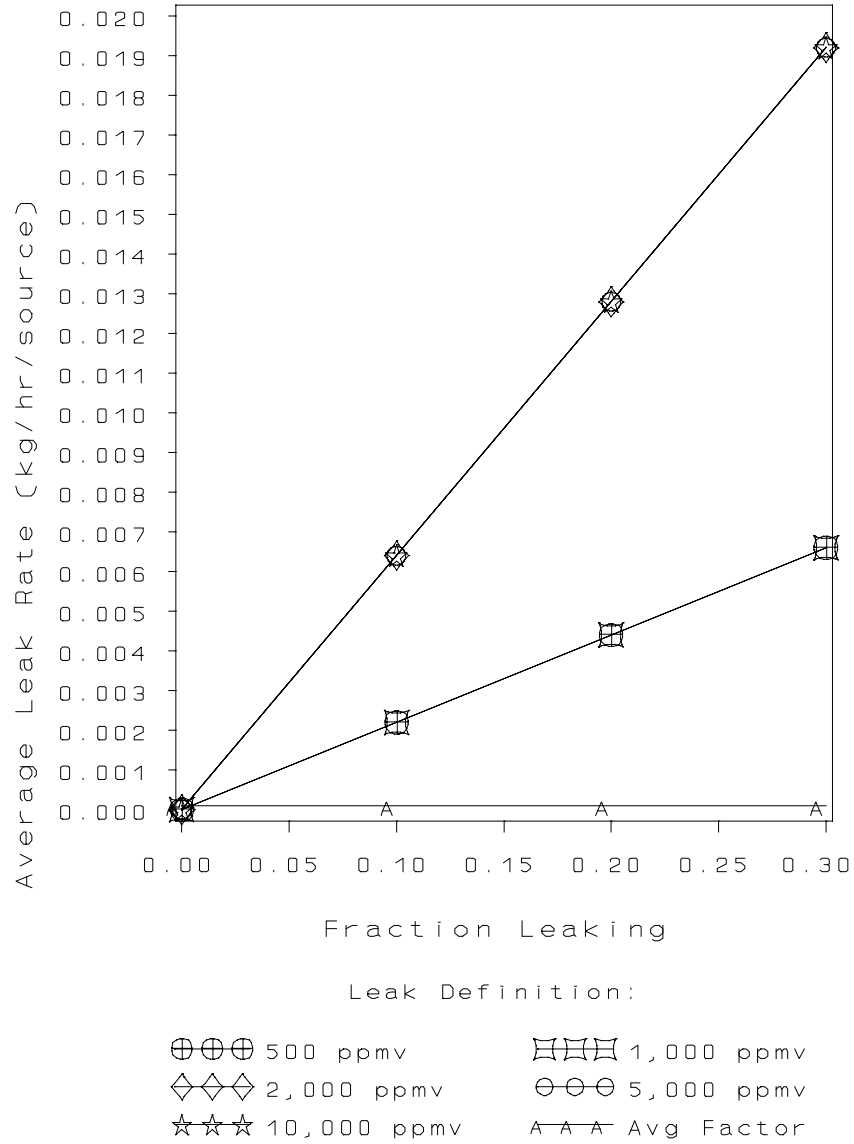

Figure 5-34. Oil and Gas Production Water/Oil Valves Average Leak Rate Versus Fraction Leaking at Several Leak Definitions

TABLE 5-4. EQUATIONS RELATING AVERAGE LEAK RATE TO FRACTION LEAKING AT SOCFMI UNITS

Equipment type	Leak definition (ppmv)	Equations ^a
Gas valve	500	ALR = (0.044 × LKFRAC) + 1.7E-05
	1000	ALR = (0.050 × LKFRAC) + 2.8E-05
	2000	ALR = (0.057 × LKFRAC) + 4.3E-05
	5000	ALR = (0.068 × LKFRAC) + 8.1E-05
	10000	ALR = (0.078 × LKFRAC) + 1.3E-04
Light liquid valve	500	ALR = (0.047 × LKFRAC) + 2.7E-05
	1000	ALR = (0.053 × LKFRAC) + 3.9E-05
	2000	ALR = (0.061 × LKFRAC) + 5.9E-05
	5000	ALR = (0.077 × LKFRAC) + 1.1E-04
	10000	ALR = (0.089 × LKFRAC) + 1.7E-04
Light liquid pump	500	ALR = (0.095 × LKFRAC) + 3.1E-04
	1000	ALR = (0.11 × LKFRAC) + 4.6E-04
	2000	ALR = (0.13 × LKFRAC) + 6.7E-04
	5000	ALR = (0.20 × LKFRAC) + 1.4E-03
	10000	ALR = (0.24 × LKFRAC) + 1.9E-03
Connector	500	ALR = (0.047 × LKFRAC) + 1.7E-05
	1000	ALR = (0.060 × LKFRAC) + 2.5E-05
	2000	ALR = (0.073 × LKFRAC) + 3.5E-05
	5000	ALR = (0.092 × LKFRAC) + 5.4E-05
	10000	ALR = (0.11 × LKFRAC) + 8.1E-05

^aALR = Average leak rate (kg/hr per source) and LKFRAC = leak fraction.

TABLE 5-5. EQUATIONS RELATING AVERAGE LEAK RATE TO FRACTION LEAKING AT REFINERY UNITS

Equipment type	Leak definition (ppmv)	Equation ^a
Gas valve	500	$ALR = (0.11 \times LKFRAC) + 8.8E-05$
	1000	$ALR = (0.13 \times LKFRAC) + 1.4E-04$
	10000	$ALR = (0.26 \times LKFRAC) + 6.0E-04$
Light liquid valve	500	$ALR = (0.038 \times LKFRAC) + 2.0E-04$
	1000	$ALR = (0.042 \times LKFRAC) + 2.8E-04$
	10000	$ALR = (0.084 \times LKFRAC) + 1.7E-03$
Light liquid pump	500	$ALR = (0.20 \times LKFRAC) + 1.3E-03$
	1000	$ALR = (0.23 \times LKFRAC) + 2.0E-03$
	10000	$ALR = (0.43 \times LKFRAC) + 1.2E-02$
Connector	500	$ALR = (0.014 \times LKFRAC) + 1.3E-05$
	1000	$ALR = (0.017 \times LKFRAC) + 1.8E-05$
	10000	$ALR = (0.037 \times LKFRAC) + 6.0E-05$

^aALR = Average leak rate (kg/hr per source) and LKFRAC = leak fraction.

TABLE 5-6. EQUATIONS RELATING AVERAGE LEAK RATE TO FRACTION LEAKING AT MARKETING TERMINAL UNITS

Equipment Type	Leak Definition (ppmv)	Equation ^a
Gas Connector	500	$ALR = (0.017 \times LKFRAC) + 5.3E-06$
	1000	$ALR = (0.017 \times LKFRAC) + 5.3E-06$
	2000	$ALR = (0.034 \times LKFRAC) + 5.9E-06$
	5000	$ALR = (0.034 \times LKFRAC) + 5.9E-06$
	10000	$ALR = (0.034 \times LKFRAC) + 5.9E-06$
Light Liquid Connector	500	$ALR = (0.0021 \times LKFRAC) + 7.0E-06$
	1000	$ALR = (0.0028 \times LKFRAC) + 7.1E-06$
	2000	$ALR = (0.0042 \times LKFRAC) + 7.1E-06$
	5000	$ALR = (0.0058 \times LKFRAC) + 7.2E-06$
	10000	$ALR = (0.0065 \times LKFRAC) + 7.2E-06$
Gas Other	500	$ALR = (0.0018 \times LKFRAC) + 3.1E-05$
	1000	$ALR = (0.0021 \times LKFRAC) + 4.0E-05$
	2000	$ALR = (0.0023 \times LKFRAC) + 4.8E-05$
	5000	$ALR = (0.0029 \times LKFRAC) + 8.4E-05$
	10000	$ALR = 1.2E-04$
Light Liquid Other	500	$ALR = (0.019 \times LKFRAC) + 2.1E-05$
	1000	$ALR = (0.022 \times LKFRAC) + 2.2E-05$
	2000	$ALR = (0.025 \times LKFRAC) + 2.2E-05$
	5000	$ALR = (0.034 \times LKFRAC) + 2.4E-05$
	10000	$ALR = (0.034 \times LKFRAC) + 2.4E-05$
Light Liquid Pump	500	$ALR = (0.014 \times LKFRAC) + 9.6E-05$
	1000	$ALR = (0.018 \times LKFRAC) + 1.2E-04$
	2000	$ALR = (0.029 \times LKFRAC) + 1.6E-04$
	5000	$ALR = (0.051 \times LKFRAC) + 2.1E-04$
	10000	$ALR = (0.077 \times LKFRAC) + 2.4E-04$

TABLE 5-6. EQUATIONS RELATING AVERAGE LEAK RATE TO FRACTION LEAKING AT MARKETING TERMINAL UNITS (CONTINUED)

Equipment Type	Leak Definition (ppmv)	Equation ^a
Gas Valve	500	$ALR = (0.0012 \times LKFRAC) + 8.9E-06$
	1000	$ALR = (0.0017 \times LKFRAC) + 9.2E-06$
	2000	$ALR = (0.0017 \times LKFRAC) + 9.2E-06$
	5000	$ALR = (0.0017 \times LKFRAC) + 9.2E-06$
	10000	$ALR = 1.3E-05$
Light Liquid Valve	500	$ALR = (0.0045 \times LKFRAC) + 9.5E-06$
	1000	$ALR = (0.0052 \times LKFRAC) + 9.8E-06$
	2000	$ALR = (0.0077 \times LKFRAC) + 1.1E-05$
	5000	$ALR = (0.013 \times LKFRAC) + 1.2E-05$
	10000	$ALR = (0.023 \times LKFRAC) + 1.5E-05$

^aALR = Average leak rate (kg/hr per source)
LKFRAC = Leak fraction.

TABLE 5-7. EQUATIONS RELATING AVERAGE LEAK RATE TO FRACTION LEAKING AT OIL AND GAS PRODUCTION OPERATION UNITS

Equipment Type	Leak Definition (ppmv)	Equation ^a
Gas Connector	500	$ALR = (0.016 \times LKFRAC) + 7.7E-06$
	1000	$ALR = (0.018 \times LKFRAC) + 8.0E-06$
	2000	$ALR = (0.020 \times LKFRAC) + 8.5E-06$
	5000	$ALR = (0.023 \times LKFRAC) + 9.4E-06$
	10000	$ALR = (0.026 \times LKFRAC) + 1.0E-05$
Light Oil Connector	500	$ALR = (0.016 \times LKFRAC) + 7.7E-06$
	1000	$ALR = (0.021 \times LKFRAC) + 8.3E-06$
	2000	$ALR = (0.022 \times LKFRAC) + 8.6E-06$
	5000	$ALR = (0.025 \times LKFRAC) + 9.2E-06$
	10000	$ALR = (0.026 \times LKFRAC) + 9.7E-06$
Water/Oil Connector	500	$ALR = (0.013 \times LKFRAC) + 7.8E-06$
	1000	$ALR = (0.014 \times LKFRAC) + 7.9E-06$
	2000	$ALR = (0.016 \times LKFRAC) + 8.3E-06$
	5000	$ALR = (0.023 \times LKFRAC) + 9.4E-06$
	10000	$ALR = (0.028 \times LKFRAC) + 1.0E-05$
Gas Flange	500	$ALR = (0.043 \times LKFRAC) + 1.1E-06$
	1000	$ALR = (0.051 \times LKFRAC) + 1.8E-06$
	2000	$ALR = (0.059 \times LKFRAC) + 2.6E-06$
	5000	$ALR = (0.075 \times LKFRAC) + 4.7E-06$
	10000	$ALR = (0.082 \times LKFRAC) + 5.7E-06$
Light Oil Flange	500	$ALR = (0.037 \times LKFRAC) + 9.4E-07$
	1000	$ALR = (0.046 \times LKFRAC) + 1.2E-06$
	2000	$ALR = (0.055 \times LKFRAC) + 1.6E-06$
	5000	$ALR = (0.068 \times LKFRAC) + 2.1E-06$
	10000	$ALR = (0.073 \times LKFRAC) + 2.4E-06$

TABLE 5-7. EQUATIONS RELATING AVERAGE LEAK RATE TO FRACTION
LEAKING AT OIL AND GAS PRODUCTION OPERATION UNITS
(CONTINUED)

Equipment Type	Leak Definition (ppmv)	Equation ^a
Gas Open-Ended Line	500	$ALR = (0.037 \times LKFRAC) + 4.1E-06$
	1000	$ALR = (0.039 \times LKFRAC) + 5.0E-06$
	2000	$ALR = (0.045 \times LKFRAC) + 7.5E-06$
	5000	$ALR = (0.051 \times LKFRAC) + 1.2E-05$
	10000	$ALR = (0.055 \times LKFRAC) + 1.5E-05$
Heavy Oil Open-Ended Line	500	$ALR = (0.012 \times LKFRAC) + 4.3E-06$
	1000	$ALR = (0.015 \times LKFRAC) + 4.9E-06$
	2000	$ALR = (0.020 \times LKFRAC) + 6.0E-06$
	5000	$ALR = (0.030 \times LKFRAC) + 7.2E-06$
	10000	$ALR = (0.030 \times LKFRAC) + 7.2E-06$
Light Oil Open-Ended Line	500	$ALR = (0.030 \times LKFRAC) + 3.8E-06$
	1000	$ALR = (0.032 \times LKFRAC) + 4.7E-06$
	2000	$ALR = (0.036 \times LKFRAC) + 6.7E-06$
	5000	$ALR = (0.040 \times LKFRAC) + 9.7E-06$
	10000	$ALR = (0.044 \times LKFRAC) + 1.4E-05$
Water/Oil Open-Ended Line	500	$ALR = (0.030 \times LKFRAC) + 3.5E-06$
	1000	$ALR = (0.030 \times LKFRAC) + 3.5E-06$
	2000	$ALR = (0.030 \times LKFRAC) + 3.5E-06$
	5000	$ALR = (0.030 \times LKFRAC) + 3.5E-06$
	10000	$ALR = (0.030 \times LKFRAC) + 3.5E-06$
Gas Other	500	$ALR = (0.055 \times LKFRAC) + 1.8E-05$
	1000	$ALR = (0.061 \times LKFRAC) + 3.1E-05$
	2000	$ALR = (0.066 \times LKFRAC) + 4.5E-05$
	5000	$ALR = (0.078 \times LKFRAC) + 8.2E-05$
	10000	$ALR = (0.089 \times LKFRAC) + 1.2E-04$

TABLE 5-7. EQUATIONS RELATING AVERAGE LEAK RATE TO FRACTION
LEAKING AT OIL AND GAS PRODUCTION OPERATION UNITS
(CONTINUED)

Equipment Type	Leak Definition (ppmv)	Equation ^a
Heavy Oil Other	500	$ALR = (0.0011 \times LKFRAC) + 2.1E-05$
	1000	$ALR = (0.0011 \times LKFRAC) + 2.1E-05$
	2000	$ALR = 3.2E-05$
	5000	$ALR = 3.2E-05$
	10000	$ALR = 3.2E-05$
Light Oil Other	500	$ALR = (0.053 \times LKFRAC) + 3.4E-05$
	1000	$ALR = (0.058 \times LKFRAC) + 4.4E-05$
	2000	$ALR = (0.067 \times LKFRAC) + 6.4E-05$
	5000	$ALR = (0.075 \times LKFRAC) + 8.6E-05$
	10000	$ALR = (0.083 \times LKFRAC) + 1.4E-04$
Water/Oil Other	500	$ALR = (0.066 \times LKFRAC) + 2.5E-05$
	1000	$ALR = (0.066 \times LKFRAC) + 2.5E-05$
	2000	$ALR = (0.066 \times LKFRAC) + 2.5E-05$
	5000	$ALR = (0.066 \times LKFRAC) + 2.5E-05$
	10000	$ALR = (0.069 \times LKFRAC) + 5.9E-05$
Gas Pump	500	$ALR = (0.027 \times LKFRAC) + 1.1E-04$
	1000	$ALR = (0.052 \times LKFRAC) + 2.3E-04$
	2000	$ALR = (0.052 \times LKFRAC) + 2.3E-04$
	5000	$ALR = (0.074 \times LKFRAC) + 3.5E-04$
	10000	$ALR = (0.074 \times LKFRAC) + 3.5E-04$
Light Oil Pump	500	$ALR = (0.071 \times LKFRAC) + 7.9E-05$
	1000	$ALR = (0.079 \times LKFRAC) + 1.5E-04$
	2000	$ALR = (0.082 \times LKFRAC) + 1.9E-04$
	5000	$ALR = (0.10 \times LKFRAC) + 5.1E-04$
	10000	$ALR = (0.10 \times LKFRAC) + 5.1E-04$

TABLE 5-7. EQUATIONS RELATING AVERAGE LEAK RATE TO FRACTION
LEAKING AT OIL AND GAS PRODUCTION OPERATION UNITS
(CONTINUED)

Equipment Type	Leak Definition (ppmv)	Equation ^a
Gas Valve	500	$ALR = (0.070 \times LKFRAC) + 9.1E-06$
	1000	$ALR = (0.076 \times LKFRAC) + 1.1E-05$
	2000	$ALR = (0.083 \times LKFRAC) + 1.4E-05$
	5000	$ALR = (0.092 \times LKFRAC) + 1.9E-05$
	10000	$ALR = (0.098 \times LKFRAC) + 2.5E-05$
Heavy Oil Valve	500	$ALR = (0.0013 \times LKFRAC) + 7.8E-06$
	1000	$ALR = (0.0013 \times LKFRAC) + 7.8E-06$
	2000	$ALR = (0.0013 \times LKFRAC) + 7.8E-06$
	5000	$ALR = 8.4E-06$
	10000	$ALR = 8.4E-06$
Light Oil Valve	500	$ALR = (0.059 \times LKFRAC) + 9.4E-06$
	1000	$ALR = (0.069 \times LKFRAC) + 1.2E-05$
	2000	$ALR = (0.075 \times LKFRAC) + 1.4E-05$
	5000	$ALR = (0.083 \times LKFRAC) + 1.7E-05$
	10000	$ALR = (0.087 \times LKFRAC) + 1.9E-05$
Water/Light Oil Valve	500	$ALR = (0.022 \times LKFRAC) + 8.1E-06$
	1000	$ALR = (0.022 \times LKFRAC) + 8.1E-06$
	2000	$ALR = (0.064 \times LKFRAC) + 9.7E-06$
	5000	$ALR = (0.064 \times LKFRAC) + 9.7E-06$
	10000	$ALR = (0.064 \times LKFRAC) + 9.7E-06$

^aALR = Average leak rate (kg/hr per source)
LKFRAC = Leak fraction.

The initial leak frequency is the fraction of sources defined as leaking before the LDAR program is implemented. The initial leak frequency is point X on figure 5-35. The lower the leak definition, the higher the initial leak frequency. At a process unit, the initial leak frequency can be determined based on collected screening data. If no screening data are available, the initial leak frequency can be assumed to be equivalent to the leak frequency associated with the applicable average emission factor. However, if a process unit already has some type of LDAR program in place, the average emission factor may overestimate emissions.

On figures 5-1 through 5-34, the average emission factor for each equipment type is plotted as a horizontal line. From this line, an initial leak frequency can be determined for any of the leak definitions. For example, on figure 5-1, which is for gas valves, the SOCFI average emission factor equals 0.00597 kilograms per hour (kg/hr). For a leak definition of 500 ppmv, this average emission factor corresponds to a fraction leaking of approximately 0.136. Similarly, for a leak definition of 10,000 ppmv, the average emission factor corresponds to a fraction leaking of 0.075. These points are determined by finding the intersection of the SOCFI average emission factor line and the applicable leak definition line and reading off the corresponding fraction leaking. Alternatively the fraction leaking associated with the average factor can be calculated using the equations in tables 5-4, 5-5, 5-6, and 5-7.

The leak frequency immediately after a monitoring cycle is Point Y on figure 5-35. After an LDAR program is implemented for a given time period, point Y will reach a "steady-state" value. As presented in figure 5-35, point Y depends on two key factors: (1) the percentage of equipment successfully repaired after being identified as leaking, and (2) the percentage of equipment that was repaired for which leaks recurred. Two simplifying assumptions when calculating point Y are: (1) that leaking equipment is instantaneously repaired, and (2) that the recurring leaks will occur instantaneously after the equipment is repaired.

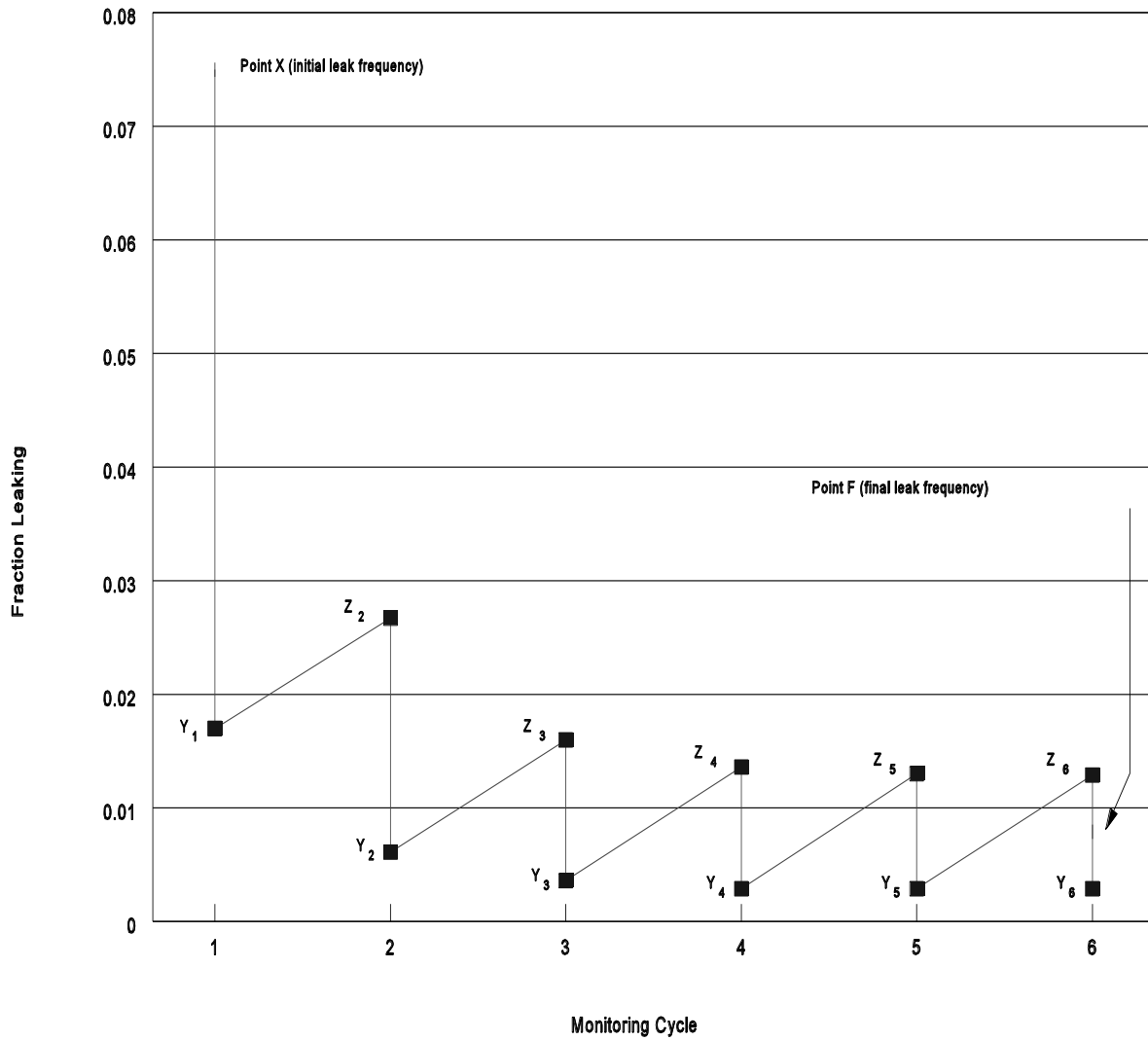

Figure 5-35. Simplified Graphical Presentation of Changes in Leak Frequency After Implementation of an LDAR Program

Based on these assumptions the value for point Y is calculated using the following equation:

$$Y_i = Z_i - (FR \times Z_i) + (FR \times Z_i \times R)$$

where:

- Y_i = Leak fraction immediately after monitoring cycle i ;
- Z_i = Leak fraction immediately preceding monitoring cycle i (note that Z_1 equals point X.);
- R = Fraction of repaired sources for which a leak immediately recurs; and
- FR = Fraction of leaking sources successfully repaired.

Point Z on figure 5-35 is the leak frequency immediately preceding equipment monitoring. After an LDAR program is implemented for a given time period, point Z will reach a "steady-state" value. To go from point Y to point Z on figure 5-35, the occurrence rate is added to point Y. The occurrence rate equals the percentage of initially nonleaking equipment that starts to leak between monitoring cycles. Use the following equation to go from point Y to point Z:

$$Z_{i+1} = Oc \times (1 - Y_i) + Y_i$$

where:

- Z_{i+1} = Leak fraction immediately preceding monitoring cycle $i + 1$;
- Oc = Fraction of nonleaking sources which will leak in the time period between monitoring cycles (i.e., occurrence rate); and
- Y_i = Leak fraction immediately after monitoring cycle i .

After several monitoring cycles, the leak frequency will be found to approximately oscillate between points Y and Z. The average value of these two "steady-state" values is the final leak frequency. This is point F on figure 5-35. The final leak frequency is the average percent of sources that are still leaking after an LDAR program has been implemented.

Once the initial and final leak frequencies are determined, they can be entered into the applicable equation from table 5-4

or table 5-5 to calculate the associated average leak rates at these leak frequencies. Based on the initial leak rate and the final leak rate, the control effectiveness for an LDAR program can be calculated. The control effectiveness is calculated as:

$$\text{Eff} = (\text{ILR}-\text{FLR})/\text{ILR} \times 100$$

where:

Eff = Control effectiveness (percent);

ILR = Initial leak rate (kg/hr/source); and

FLR = Final leak rate (kg/hr/source).

5.3.2 Example Application of Approach

As previously mentioned, the approach described in section 5.3.1 was applied to estimate the control effectiveness for three types of LDAR programs: (1) monthly inspection with a leak definition of 10,000 ppmv, (2) quarterly inspection with a leak definition of 10,000 ppmv, and (3) a program complying with the requirements specified in the proposed hazardous organic NESHAP equipment leaks negotiated regulation.¹ Details of these calculations are presented in appendix G. As an example of applying the approach, the control effectiveness for gas valves at a SOCFI process unit implementing a monthly LDAR program with a leak definition of 10,000 ppmv is presented in the following paragraphs.

Table 5-8 presents the SOCFI gas valve occurrence rate, recurrence rate, unsuccessful repair rate, and initial leak frequency. (See appendix G for details on how each of these parameters were determined.) Using the values presented in table 5-6 and the approach presented in section 5.3.1, the LDAR control effectiveness can be calculated. Note that figure 5-9 is also based on monthly monitoring of gas valves in a SOCFI process unit with a leak definition of 10,000 ppmv, and it is referred to in this example demonstration.

For gas valves with a leak definition of 10,000 ppmv, the initial leak frequency is 7.5 percent. This initial leak frequency value is taken from figure 5-1, by finding the value of

TABLE 5-8. VALUES USED IN EXAMPLE CALCULATION^a

Source Category:	SOCMI
Equipment Type:	Gas Valves
LDAR Program:	Monthly Monitoring with a Leak Definition of 10,000 ppmv
Occurrence Rate:	1.00%
Recurrence Rate:	14%
Unsuccessful Repair Rate:	10%
Initial Leak Frequency: ^b	7.5%

^aSee appendix F for information on how the occurrence rate, recurrence rate, and unsuccessful repair rate were determined.

^bBased on the SOCMI average emission factor for gas valves.

the fraction leaking at the intersection of the SOCFI average factor line and the 10,000-ppmv leak definition line. The initial leak rate for this leak frequency is the SOCFI gas valve average emission factor, which equals 0.00597. After the LDAR program is implemented and monitoring occurs on a monthly basis, the steady-state leak frequency immediately after monitoring (see point Y₆ on figure 5-35) equals 0.29 percent. The steady-state leak frequency prior to monitoring (see point Z₆ on figure 5-35) equals 1.29 percent. This gives an average of 0.79 percent as the final leak frequency (see point F on figure 5-35). The calculations performed to determine the final leak frequency are shown in table 5-9. Once the estimated gas valve final leak frequency is determined, the associated leak rate can be found using figure 5-1 or the gas valve equation for a leak definition of 10,000 ppmv listed on table 5-4. The corresponding leak rate associated with the final leak frequency of 0.79 percent at a leak definition of 10,000 ppmv is 0.00075 kg/hr. Thus, the control effectiveness of a monthly LDAR program with a leak definition of 10,000 ppmv for gas valves is:

$$\begin{aligned} &= (0.00597-0.00075)/0.00597 \times 100 \\ &= 87 \text{ percent.} \end{aligned}$$

TABLE 5-9. EXAMPLE CALCULATION TO DETERMINE THE FINAL LEAK FREQUENCY OF SOCOMI GAS VALVES IN A MONTHLY MONITORING LDAR PROGRAM WITH A LEAK DEFINITION OF 10,000 PPMV^a

Starting parameters	Resulting parameters
1. Leak definition: = 10,000 ppmv	1. Steady-state leak frequency after monitoring (Point Y ₆): = 0.29 percent
2. Leak occurrence (O _c): = 1.00 percent	2. Steady-state leak frequency immediately prior to monitoring (Point Z ₆): = 1.29 percent
3. Leak recurrence (R): = 14 percent	3. Final leak frequency (Point F) ^b : = 0.79 percent
4. Successful repair rate (FR): = 90 percent	
5. Initial leak frequency (Point X): = 7.5 percent	
<u>Calculations</u>	
Monitoring cycle	Leak frequency after monitoring: Point Y _i (percent) ^c
1	1.70
2	0.61
3	0.36
4	0.31
5	0.29
6 ^e	0.29
	Leak frequency prior to monitoring: Point Z _i (percent) ^d
	7.50
	2.67
	1.60
	1.36
	1.30
	1.29

^aRefer to Figure 5-4 for graphical presentation of all points identified in this table.

^bFinal Leak Frequency equals the average of the prior to monitoring and after monitoring steady-state leak frequencies.

$$cY_i = Z_i - (FR * Z_i) + (FR * Z_i * R)$$

$$dZ_i + 1 = O_c * (1 - Y_i) + Y_i$$

^eAfter the sixth monitoring cycle, the values for Y_i and Z_i reach steady-state.

5.4 REFERENCES

1. National Emission Standards for Hazardous Air Pollutants for Source Categories; Organic Hazardous Air Pollutants from the Synthetic Organic Chemical Manufacturing Industry and Seven Other Processes. Subpart H--Equipment Leaks. Federal Register. Vol. 57, No. 252, pp 62765-62785. Washington, DC. Office of the Federal Register. December 31, 1992.