



**OIL DISCHARGE PREVENTION
AND
CONTINGENCY PLAN**

**POINT THOMSON GAS CYCLING PROJECT
NORTH SLOPE, ALASKA**

**PREAPPLICATION
DRAFT**

MAY 2003

MANAGEMENT APPROVAL AND MANPOWER AUTHORIZATION

OIL DISCHARGE PREVENTION AND CONTINGENCY PLAN POINT THOMSON GAS CYCLING PROJECT NORTH SLOPE, ALASKA

This Oil Discharge Prevention and Contingency Plan (ODPCP) has been prepared for Exxon Mobil Corporation, hereinafter ExxonMobil, proposed operations at Point Thomson, North Slope, Alaska. The operations include drilling, production, storage, transfer, and field maintenance.

This plan is approved for implementation as herein described. Manpower, training, management system, equipment, and materials will be provided as required in accordance with this plan.

ExxonMobil's approach to oil spills will be based on the following priorities:

1. Safety of personnel
2. Prevention of spills
3. Protection of the environment
4. Protection of facilities

Randy F. Buckley
Project Manager
ExxonMobil Development Company
on behalf of Exxon Mobil Corporation

Date

ENGINEER SPCC CERTIFICATION

Incorporated into this ODPCP is the Spill Prevention, Control, and Countermeasure (SPCC) Plan for the Point Thomson facility required by Title 40, Code of Federal Regulations Part 112 (40 CFR 112). 40 CFR 112 requires an SPCC plan be reviewed and certified by a professional engineer to be considered in effect. Specifically, 40 CFR 112.3(d) requires:

No SPCC Plan shall be effective to satisfy the requirements of this part unless it has been reviewed and certified by a Registered Professional Engineer. By means of this certification, the professional engineer attests that:

- i) He/she is familiar with the requirements of the SPCC rule;
- ii) He/she or his/her agent has visited and examined the facility;
- iii) The ODPCP has been prepared in accordance with good engineering practice, including consideration of applicable industry standards, and with the requirements of the SPCC rule;
- iv) Procedures for required inspections and testing have been established; and
- v) The ODPCP is adequate for the facility.

Because the ODPCP integrates many aspects of spill response planning, including response and prevention, the engineer must certify that only those sections that apply directly to SPCC requirements have been prepared according to good engineering practice and are adequate for the facility. Sections of the ODPCP which do not apply directly to SPCC requirements, such as information on the biology, geology, or climate of the area, or to response activities, do not require engineering certification because no engineering practice is involved.

I hereby certify that (1) I or my agent have examined the facility, (2) I am familiar with the provisions of 40 CFR 112, (3) the sections of this ODPCP applicable to SPCC requirements have been prepared in accordance with good engineering practice, including consideration of applicable industry standards, and in accordance with the requirements of 40 CFR 112, (4) required inspections and testing procedures have been established, and that (5) this ODPCP is adequate for the facility.

Printed name of Registered Engineer

Signature of Registered Professional Engineer

Registration No. _____

State _____

Registration expires: _____

Date: _____

OIL DISCHARGE PREVENTION AND CONTINGENCY PLAN POINT THOMSON

TABLE OF CONTENTS

MANAGEMENT APPROVAL AND MANPOWER AUTHORIZATION	i
SPCC CERTIFICATION	ii
RECORD OF REVISIONS	iii
TABLE OF CONTENTS	T-1
LIST OF ACRONYMS	T-9
INTRODUCTION	I-1
Plan Distribution	I-1
Updating Procedures.....	I-1
Plan Renewal	I-2
PART 1, RESPONSE ACTION PLAN [18 AAC 75.425(e)(1)]	1-1
1. RESPONSE ACTION PLAN [18 AAC 75.425(e)(1)]	1-1
1.1 EMERGENCY ACTION CHECKLIST [18 AAC 75.425(e)(1)(A)].....	1-1
1.1.1 Operator and Contacts	1-1
1.1.2 Response Levels.....	1-1
1.2 REPORTING AND NOTIFICATION [18 AAC 75.425(e)(1)(B)].....	1-4
1.2.1 Internal Notification Procedures	1-4
1.2.2 External Notification Procedures	1-11
1.2.3 Qualified Individual Notification and Responsibilities	1-11
1.2.4 Written Reporting Requirements [18 AAC 75.300]	1-18
1.3 SAFETY [18 AAC 75.425(e)(1)(C)]	1-18
1.4 COMMUNICATIONS [18 AAC 75.425(e)(1)(D)]	1-19
1.5 DEPLOYMENT STRATEGIES [18 AAC 75.425(e)(1)(E)]	1-20
1.5.1 Transport Procedures [18 AAC 75.425(e)(1)(E)(i)]	1-20
1.5.2 Notification and Mobilization of Response Action Contractor [18 AAC 75.425(e)(1)(E)(ii)]	1-21
1.6 RESPONSE STRATEGIES [18 AAC 75.425(e)(1)(F)].....	1-21
1.6.1 Procedures to Stop Discharge [18 AAC 75.425(e)(1)(F)(i)]	1-21
1.6.2 Fire Prevention and Control [18 AAC 75.425(e)(1)(F)(ii)]	1-24
1.6.3 Blowout Response [18 AAC 75.425(e)(1)(F)(iii)].....	1-26
1.6.4 Discharge Tracking [18 AAC 75.425(e)(1)(F)(iv)]	1-39
1.6.5 Protection of Sensitive Areas [18 AAC 75.425(e)(1)(F)(v)].....	1-39
1.6.6 Containment and Control Strategies [18 AAC 75.425(e)(1)(F)(vi)]	1-40
1.6.7 Recovery Strategies [18 AAC 75.425(e)(1)(F)(vii)]	1-40
1.6.8 Lightering, Transfer, and Storage of Oil from Tanks [18 AAC 75.425(e)(1)(F)(viii)]	1-40

TABLE OF CONTENTS (CONTINUED)

1.6.9	Transfer and Storage Strategies [18 AAC 75.425(e)(1)(F)(ix)]	1-40
1.6.10	Temporary Storage and Disposal [18 AAC 75.425(e)(1)(F)(x)]	1-40
1.6.11	Wildlife Protection [18 AAC 75.425(e)(1)(F)(xi)]	1-41
1.6.12	Shoreline Cleanup [18 AAC 75.425(e)(1)(F)(xii)]	1-41
1.6.13	Response Planning Standards [18 AAC 75.430]	1-42
1.6.14	Response Scenarios [18 AAC 75.425(e)(1)(F)]	1-47
1.7	NONMECHANICAL RESPONSE OPTIONS [18 AAC 75.425(e)(1)(G)]	1-119
1.7.1	Obtaining Permits and Approvals	1-119
1.7.2	Decision Criteria for Use	1-119
1.7.3	Implementation Procedures	1-119
1.7.4	Required Equipment and Personnel	1-119
1.8	FACILITY DIAGRAMS [18 AAC 75.425(e)(1)(H)]	1-119
PART 2, PREVENTION PLAN [18 AAC 75.425(e)(2)]		2-1
2.	PREVENTION PLAN [18 AAC 75.425(e)(2)]	2-1
2.1	PREVENTION, INSPECTION, AND MAINTENANCE PROGRAMS [18 AAC 75.425(e)(2)(A)]	2-1
2.1.1	Prevention Training Programs [18 AAC 75.007(d)]	2-1
2.1.2	Substance Abuse Programs [18 AAC 75.007(e)]	2-3
2.1.3	Medical Monitoring [18 AAC 75.007(e)]	2-4
2.1.4	Security Programs [18 AAC 75.007(f)]	2-5
2.1.5	Fuel Transfer Procedures [18 AAC 75.025]	2-5
2.1.6	Operating Requirements for Exploration and Production Facilities [18 AAC 75.045]	2-7
2.1.7	Blowout Control [18 AAC 75.425(e)(1)(F)(iii)]	2-8
2.1.8	Leak Detection, Monitoring, and Operating Requirements for Crude Oil Transmission Pipelines [18 AAC 75.055]	2-14
2.1.9	Facility Piping Requirements for Oil Terminal, Crude Oil Transmission Pipeline, Exploration, and Production Facilities [18 AAC 75.080]	2-15
2.1.10	Oil Storage Tanks [18 AAC 75.065]	2-18
2.1.11	Secondary Containment Areas [18 AAC 75.075]	2-18
2.2	DISCHARGE HISTORY [18 AAC 75.425(e)(2)(B)]	2-19
2.3	POTENTIAL DISCHARGE ANALYSIS [18 AAC 75.425(e)(2)(C)]	2-19
2.4	CONDITIONS INCREASING RISK OF DISCHARGE [18 AAC 75.425(e)(2)(D)]	2-19
2.5	DISCHARGE DETECTION [18 AAC 75.425(e)(2)(E)]	2-21
2.5.1	Drilling Operations	2-21
2.5.2	Automated Methods for Processes and Tanks	2-21
2.5.3	Pipelines	2-22
2.5.4	Fire and Gas Alarm System (Process Areas)	2-23
2.5.5	Inspections	2-23
2.6	RATIONALE FOR CLAIMED PREVENTION CREDITS [18 AAC 75.425(e)(2)(F)]	2-24
2.6.1	Well Blowout RPS	2-26
2.6.2	Tank Rupture RPS	2-30
2.6.3	Condensate Export Pipeline RPS	2-31
2.7	COMPLIANCE SCHEDULE AND WAIVERS [18 AAC 75.425(e)(2)(G)]	2-32
PART 3, SUPPLEMENTAL INFORMATION [18 AAC 75.425(e)(3)]		3-1
3.	SUPPLEMENTAL INFORMATION [18 AAC 75.425(e)(3)]	3-1

TABLE OF CONTENTS (CONTINUED)

3.1	FACILITY DESCRIPTION AND OPERATIONAL OVERVIEW [18 AAC 75.425(e)(3)(A)]	3-1
3.1.1	Facility Ownership, Location, and General Description.....	3-1
3.1.2	Facility Storage Containers [18 AAC 75.425(e)(3)(A)(i) and (ii)].....	3-2
3.1.3	Transfer Procedures [18 AAC 75.425(e)(3)(A)(v)].....	3-2
3.1.4	Description and Operation of Production Facilities [18 AAC 75.425(e)(3)(A)(vi)]	3-2
3.2	RECEIVING ENVIRONMENT [18 AAC 75.425(e)(3)(B)]	3-11
3.2.1	Water and Weather.....	3-11
3.2.2	Sea Ice	3-18
3.2.3	Potential Routes of Discharges [18 AAC 75.425(e)(3)(B)(i)].....	3-27
3.2.4	Estimate of RPS Volume to Reach Open Water [18 AAC 75.425(e)(3)(B)(ii)]	3-27
3.3	COMMAND SYSTEM [18 AAC 75.425(e)(3)(C)]	3-28
3.4	REALISTIC MAXIMUM RESPONSE OPERATING LIMITATIONS [18 AAC 75.425(e)(3)(D)] .	3-29
3.5	LOGISTICAL SUPPORT [18 AAC 75.425(e)(3)(E)]	3-30
3.6	RESPONSE EQUIPMENT [18 AAC 75.425(e)(3)(F)]	3-30
3.6.1	Equipment Lists.....	3-30
3.6.2	Maintenance and Inspection of Response Equipment.....	3-30
3.6.3	Pre-Deployed Equipment	3-30
3.7	NONMECHANICAL RESPONSE INFORMATION [18 AAC 75.425(e)(3)(G)]	3-34
3.8	RESPONSE CONTRACTOR INFORMATION [18 AAC 75.425(e)(3)(H)]	3-34
3.9	TRAINING AND DRILLS [18 AAC 75.425(e)(3)(I)]	3-34
3.9.1	NSSRT Training	3-34
3.9.2	Incident Management Team Training	3-37
3.9.3	Auxiliary Contract Response Team.....	3-38
3.9.4	Record Keeping.....	3-38
3.9.5	Spill Response Exercise	3-38
3.10	PROTECTION OF ENVIRONMENTALLY SENSITIVE AREAS [18 AAC 75.425(e)(3)(J)]	3-40
3.11	ADDITIONAL INFORMATION [18 AAC 75.425(e)(3)(K)]	3-40
3.12	BIBLIOGRAPHY [18 AAC 75.425(e)(3)(L)]	3-41
PART 4, BEST AVAILABLE TECHNOLOGY [18 AAC 75.425(e)(4)]		4-1
4.	BEST AVAILABLE TECHNOLOGY [18 AAC 75.425(e)(4)]	4-1
4.1	COMMUNICATIONS [18 AAC 75.425(e)(4)(i)]	4-1
4.2	SOURCE CONTROL [18 AAC 75.425(e)(4)(A)(i)]	4-1
4.2.1	Well Source Control	4-1
4.2.2	Pipeline Source Control.....	4-6
4.2.3	Tank Source Control	4-6
4.3	TRAJECTORY ANALYSES [18 AAC 75.425(e)(4)(A)(i)]	4-10
4.4	WILDLIFE CAPTURE, TREATMENT, AND RELEASE PROGRAMS [18 AAC 75.425(e)(4)(A)(i)]	4-10
4.5	CATHODIC PROTECTION [18 AAC 75.425(e)(4)(A)(ii)]	4-10

TABLE OF CONTENTS (CONTINUED)

4.6	LEAK DETECTION SYSTEMS FOR TANKS [18 AAC 75.425(e)(4)(ii)]	4-10
4.7	LEAK DETECTION FOR CRUDE OIL TRANSMISSION PIPELINES [18 AAC 75.425(e)(4)(A)(iv)]	4-10
4.8	LIQUID LEVEL DETERMINATION [18 AAC 75.425(e)(4)(A)(ii)]	4-15
4.9	PROTECTIVE WRAPPING OR COATINGS FOR TANKS AND PIPELINES [18 AAC 75.425(e)(4)(A)(ii)]	4-22
4.9.1	Tank Corrosion Protective Coating	4-22
4.9.2	Pipeline Corrosion Protective Coating.....	4-23
4.10	CATHODIC PROTECTION FOR TANKS AND PIPELINES [18 AAC 75.425(e)(4)(A)(ii)]	4-23
4.10.1	Tanks	4-23
4.10.2	Pipelines.....	4-23

APPENDICES

Appendix A	Best Management Practices and Procedures	A-1
Appendix B	Point Thomson Regulated Tanks Lists	B-1
Appendix C	OPA 90 Addendum	
	U.S. Environmental Protection Agency	EPA-1
	U.S. Department of Transportation	DOT-1
	U.S. Coast Guard	USCG-1

TABLE OF CONTENTS (CONTINUED)

LIST OF FIGURES

1-1	Immediate Spill Notifications	1-5
1-2	Point Thomson Incident Management Team for Level II/III	1-6
1-3	Spill Report Form	1-12
1-4	Surface Transport Seasons	1-22
1-5A	General Surface Intervention Options	1-27
1-5B	Well Ignition Decision Tree	1-28
1-5C	Relief Well Options during the Year	1-36
1-5D	Winter Mobilization for Relief Well	1-37
1-5E	Summer Mobilization for Relief Well	1-38
1-6	Condensate Export Pipeline Spill to Open Water Scenario Vicinity Map	1-61
1-7	Condensate Export Pipeline Spill to Open Water Scenario	1-62
1-8	Condensate Export Pipeline Spill During Break-Up Scenario Vicinity Map	1-71
1-9	Condensate Export Pipeline Spill During Break-Up Scenario	1-72
1-10	Diesel Tank Rupture During Summer Vicinity Map	1-81
1-11	Diesel Tank Rupture During Summer	1-82
1-12	Diesel Tank Rupture During Freeze-Up Vicinity Map	1-91
1-13	Diesel Tank Rupture During Freeze-Up	1-92
1-14	Blowout During Winter: Extent of Blowout Plume Prior to Ignition	1-103
1-15	Blowout During Winter: Recovery Tactics	1-104
1-16	Blowout During Summer: Extent of Blowout Plume Prior to Ignition	1-116
1-17	Blowout During Summer: Recovery Tactics	1-117
1-18	Point Thomson Gas Cycling Project Vicinity Map	1-120
1-19	Pipeline and Valve Locations	1-121
1-20	Central Well Pad	1-122
1-21	Central Processing Facility	1-123
1-22	East Well Pad	1-124
1-23	West Well Pad	1-125
2-1	Operational Integrity Management System Elements	2-2
2-2	Technology Integration with IP3	2-10
2-3	The Relationship Between Corrosion Control and Monitoring Programs	2-16
3-1	Simplified Flow Diagram	3-5
3-2	Three Train Injection Case	3-6
3-3	Wind Direction Frequencies at Barter Island	3-12
3-4	General Location Map Showing the Ice Discussion Area	3-19
3-5	Landsat 4 Image June 13, 1986, Showing Coastal Ice Conditions Approximately 48 Hours Following Floodwater Drainage from The Major Rivers	3-22
3-6	Deteriorated Ice in the Lagoon Areas	3-23
3-7	Landsat 7 July 23, 2001, Showing Open Water Along the Coast from Brownlow Point to West Dock	3-24

TABLE OF CONTENTS (CONTINUED)

LIST OF TABLES

1-1A	Immediate Action Checklist.....	1-7
1-1B	Immediate Response and Notification Actions.....	1-9
1-2	ExxonMobil Contact List.....	1-13
1-3	Agency Reporting Requirements for Oil Spills	1-15
1-4	Drilling Supervisor Checklist for Immediate Blowout Response	1-29
1-5	Emergency Well Ignition Procedures.....	1-29
1-6	Conditions for Pre-Authorized Well Ignition	1-30
1-7	Surface Intervention Equipment List	1-32
1-8	Summary of Condensate Characterizations for Release to the Atmosphere (Mole Percent).....	1-44
1-9	Condensate Export Pipeline Spill to Open Water Scenario Conditions	1-53
1-10	Condensate Export Pipeline Spill to Open Water Response Strategy.....	1-55
1-11	Condensate Export Pipeline Spill to Open Water Oil Recovery Capacity	1-57
1-12	Condensate Export Pipeline Spill to Open Water Liquid Handling Capability	1-57
1-13	Condensate Export Pipeline Spill to Open Water Major Equipment Equivalents to Meet the Response Planning Standard.....	1-58
1-14	Condensate Export Pipeline Spill to Open Water Equipment for Shoreline Protection	1-58
1-15	Condensate Export Pipeline Spill to Open Water Staffing to Operate Oil Recovery and Transfer Equipment	1-59
1-16	Condensate Export Pipeline Spill to Open Water Staffing for Shoreline Protection	1-59
1-17	Condensate Export Pipeline Spill During Break-Up Scenario Conditions	1-65
1-18	Condensate Export Pipeline Spill During Break-Up Response Strategy.....	1-67
1-19	Condensate Export Pipeline Spill During Break-Up Oil Recovery Capacity.....	1-69
1-20	Condensate Export Pipeline Spill During Break-Up Liquid Handling Capability.....	1-69
1-21	Condensate Export Pipeline Spill During Break-Up Major Equipment Equivalents to Meet the Response Planning Standard.....	1-70
1-22	Condensate Export Pipeline Spill During Break-Up Staffing to Operate Oil Recovery and Transfer Equipment	1-70
1-23	Diesel Tank Rupture During Summer Scenario Conditions.....	1-75
1-24	Diesel Tank Rupture During Summer Response Strategy	1-77
1-26	Diesel Tank Rupture During Summer Oil Recovery Capacity.....	1-79
1-27	Diesel Tank Rupture During Summer Liquid Handling Capability.....	1-79
1-28	Diesel Tank Rupture During Summer Major Equipment for Recovery and Transfer.....	1-80
1-29	Diesel Tank Rupture During Summer Staffing to Operate Oil Recovery and Transfer Equipment.....	1-80
1-30	Diesel Tank Rupture During Freeze-Up Scenario Conditions.....	1-85
1-31	Diesel Tank Rupture During Freeze-Up Response Strategy	1-87
1-32	Diesel Tank Rupture During Freeze-Up Oil Recovery Capacity	1-89
1-33	Diesel Tank Rupture During Freeze-Up Liquid Handling Capability	1-89
1-34	Diesel Tank Rupture During Freeze-Up Major Equipment for Recovery and Transfer.....	1-90
1-35	Diesel Tank Rupture During Freeze-Up Staffing to Operate Oil Recovery and Transfer Equipment.....	1-90
1-36	Point Thomson Blowout During Winter Scenario Conditions.....	1-95
1-37	Point Thomson Blowout During Winter Response Strategy.....	1-97
1-38	Point Thomson Blowout During Winter Oil Recovery Capacity.....	1-100
1-39	Point Thomson Blowout During Winter Major Equipment Equivalents to Meet the Response Planning Standard.....	1-101
1-40	Point Thomson Blowout During Winter Number of Staff Per Shift to Operate Oil Recovery and Transfer Equipment.....	1-101
1-41	Point Thomson Condensate Blowout During Summer Scenario Conditions	1-107
1-42	Point Thomson Condensate Blowout During Summer Response Strategy	1-109

TABLE OF CONTENTS (CONTINUED)

1-43	Point Thomson Condensate Blowout During Summer Oil Recovery Capacity	1-112
1-44	Point Thomson Condensate Blowout During Summer Liquid Handling Capability	1-113
1-45	Point Thomson Condensate Blowout During Summer Major Equipment Equivalents to Meet the Response Planning Standard.....	1-114
1-46	Point Thomson Condensate Blowout During Summer Number of Staff Per Shift to Operate Oil Recovery and Transfer Equipment	1-115
2-1	Analyses of Potential Discharges.....	2-20
2-2	Visual Surveillance Schedule	2-25
3-1	Condensate and Reservoir Characteristics	3-1
3-2	Well Counts	3-7
3-3	Summary Of Condensate Production Pipelines.....	3-8
3-4	Barter Island Average Ambient Temperature (°F).....	3-11
3-5	Prudhoe Bay Yearly Probability of Temperature Occurrence	3-12
3-6	Mean and Instantaneous Wind	3-13
3-7	Climate Data for Yukon Gold Ice Pad Area (Inland) and Barter Island (Coastal)	3-13
3-8	Oceanographic Data Summary.....	3-14
3-9	Historical Break-Up Sequence for the Canning River, 1974-1990 (Atwater 1991)	3-22
3-10	Spill Response Equipment	3-31
3-11	Other Equipment Positioned at Point Thomson	3-33
3-12	On-Water Marine Equipment Positioned at Point Thomson	3-34
3-13	North Slope Spill Response Team Minimum Staffing Levels.....	3-35
3-14	Typical North Slope Spill Response Team Training Courses	3-39
4-1	Best Available Technology Analysis Well Blowout Source Control.....	4-2
4-2	Best Available Technology Analysis Source Control on Condensate Export Pipeline	4-7
4-3	Best Available Technology Analysis Gathering and Well Oil Line Source Control.....	4-8
4-4	Best Available Technology Analysis Tank Source Control.....	4-9
4-5	Best Available Technology Analysis Tank Leak Detection.....	4-11
4-6	Best Available Technology Analysis Leak Detection for Condensate Export Pipeline	4-13
4-7A	Best Available Technology Stationary Storage Tank Liquid Level Determination.....	4-17
4-7B	Best Available Technology Analysis Portable Storage Tank Liquid Level Determination System	4-21
4-8	Best Available Technology Analysis External Coatings for Below Grade Sections of Pipeline...	4-24

THIS PAGE INTENTIONALLY LEFT BLANK

LIST OF ACRONYMS AND ABBREVIATIONS

°C	degrees Celsius
°F	degrees Fahrenheit
µg/m ³	micrograms per cubic meter
~	approximately
<	less than
>	greater than
AAC	Alaska Administrative Code
ACP	Area Contingency Plan
ACS	Alaska Clean Seas
ADEC	Alaska Department of Environmental Conservation
ADNR	Alaska Department of Natural Resources
AOGCC	Alaska Oil and Gas Conservation Commission
API	American Petroleum Institute
APSC	Alyeska Pipeline Service Company
ARRT	Alaska Regional Response Team
ASME	American Society of Mechanical Engineers
ATVs	all terrain vehicles
avg.	Average
Badami	Badami Development Area
BAT	best available technology
bbl	barrels
bscf/d	billion standard cubic feet per day
BHA	bottom hole assembly
BOP	blowout preventer
bopd	barrels of oil per day
BOPE	blowout preventer equipment
boph	barrels of oil per hour
bpd	barrels per day
bph	barrels per hour
BPMSCF	barrels per million standard cubic feet
bpm	barrels per minute
BMP	Best Management Practices
BPXA	BP Exploration (Alaska) Inc.
BS&W	basic sediment and water
BTU	British Thermal Units
CCR	Central Control Room
CFR	Code of Federal Regulations
cfs	cubic feet per second
CIC	Corrosion, Inspection and Chemicals Team
CMT	Crisis Management Team
CO ₂	carbon dioxide
CPF	Central Processing Facility
CRA	corrosion-resistant alloy
CWP	Central Well Pad
DCS	distributed control system
DOT	U.S. Department of Transportation
EIS	Environmental Impact Statement

LIST OF ACRONYMS AND ABBREVIATIONS (CONTINUED)

EPA	U.S. Environmental Protection Agency
ERD	extended reach drilling
ERM	erosion rate monitoring
EREPs	Emergency Response and Evacuation Plans
ESD	emergency shutdown
ESV	emergency shutdown valve
FOSC	Federal On-Scene Coordinator
FRP	Facility Response Plan
G&I	grind-and-inject
GHz	gigahertz
GOR	gas-to-oil ratio
gpm	gallons per minute
GPS	global positioning system
H ₂ S	hydrogen sulfide
HAZMAT	hazardous materials
HAZWOPER	Hazardous Waste Operations and Emergency Response
hp	horsepower
hpd	hours per day
HQ	Headquarters
IADC	International Association of Drilling Contractors
ICS	Incident Command System
ICSS	Integrated Control and Safety System
IEC	International Electrotechnical Commission
IMT	Incident Management Team
in.	inches
IP3	Integrated Pore Pressure Prediction
IR	infrared
ISB	<i>in situ</i> burning
KBPD	thousand barrels per day
kV	kiloVolt
lbs.	pounds
LEL	lower explosive limit
LEPC	Local Emergency Planning Committee
LF	linear foot
LOSC	Local On-Scene Coordinator
m ³ /s	cubic meters per second
MAD	Mutual Aid Drill
MAOP	maximum allowable operating pressure
MB	Mass Balance
MBLPC	Mass Balance Line Pack Compensation
mcf/d	thousand cubic feet per day
MIC	Microbially-Induced Corrosion
min	minute
mm	millimeter
MMS	Minerals Management Service
mmscf	million standard cubic feet
mmscf/d	million standard cubic feet per day
MOB RU	mobilization and rig-up

LIST OF ACRONYMS AND ABBREVIATIONS (CONTINUED)

mph	miles per hour
MSL	mean sea level
MSRC	Marine Spill Response Corporation
MWD	Measurement While Drilling
MWP	maximum working pressure
NA	not applicable
NARRT	North American Regional Response Team
NCP	National Contingency Plan
NDE	Non-destructive Examination
NOAA	National Oceanic and Atmospheric Administration
NM	nautical miles
NPREP	National Preparedness for Response Exercise Program
NSB	North Slope Borough
NSSRT	North Slope Spill Response Team
NSTC	North Slope Training Cooperative
ODPCP	Oil Discharge Prevention and Contingency Plan
OIMS	Operations Integrity Management System
OPA 90	Oil Pollution Act of 1990
OSD	operational shutdown
OSEA	Office of Safety and Environmental Affairs
OSHA	Occupational Safety and Health Administration
OSRO	Oil Spill Removal Organization
OSRV	oil spill response vessel
oz.	ounce
PIC	person-in-charge
PBU	Prudhoe Bay Unit
PCS	Process Control System
Plan	Point Thomson ODPCP
PLC	Programmable Logic Controller
PM	particulate matter
PPE	personal protective equipment
ppg	pounds per gallon
PSD	process shutdown
psi	pounds per square inch
psia	pounds per square inch absolute
psig	pounds per square inch gauge
PSV	pressure safety valve
PTU	Point Thomson Unit
PU	polyurethane
PVC	polyvinyl chloride
PVT	pit volume totalizer
QI	Qualified Individual
QRA	quantitative risk assessment
RACs	Response Action Contractors
RCG	Regulatory Compliance Group
RMROL	realistic maximum response operating limitation
RPS	response planning standard
RTTM	Real-Time Transient Model

LIST OF ACRONYMS AND ABBREVIATIONS (CONTINUED)

SAPOC	Statistical Analysis of Pipeline Operating Conditions
SCADA	Supervisory Control and Data Acquisition
SCAT	Shoreline Cleanup Assessment Team
scf/bbl	standard cubic feet per barrel
scf/d	standard cubic feet per day
SCSSV	surface-controlled subsurface safety valves
SDV	shutdown valves
SEPC	State Emergency Planning Committee
SHE	Safety, Health and Environment
SIS	Safety Instrumented Systems
SOP	standard operating procedures
SOSC	State On-Scene Coordinator
SPCC	Spill Prevention, Control, and Countermeasures
SPLO	State Pipeline Office
SPOC	single point of contact
SRT	Spill Response Team
SSSV	subsurface safety valve
SSV	surface safety valve
TAPS	Trans Alaska Pipeline System
TBD	to be determined
tscf	trillion standard cubic feet
TF	Task Force
TPS	total plant shutdown
TRUE	Training to Reduce Unexpected Events
TVD	total vertical depth
UHF	ultrahigh frequency
UIC	Underground Injection Control
UOP	Unified Operating Procedure
UPS	uninterrupted power supply
USCG	U.S. Coast Guard
USFWS	U.S. Fish and Wildlife Service
USI	upset shut-in
UV	ultraviolet
VHF	very high frequency
VOSS	vessel-of-opportunity skimming systems
VSM	vertical support members
WCD	worst-case discharge
WP	working pressure
yd.	Yard

INTRODUCTION

This Oil Discharge Prevention and Contingency Plan (ODPCP) is for the Point Thomson Unit (PTU). ExxonMobil Development Company (ExxonMobil), on behalf of Exxon Mobil Corporation, is the operator of the facility, located near the Beaufort Sea, 60 miles east of Prudhoe Bay, Alaska. ExxonMobil's address, phone, and fax numbers are provided below:

ExxonMobil
P.O. Box 196601
Anchorage, AK 99519
Phone: (907) 561-5331

Street Address:
3301 C Street, Suite 400
Anchorage, AK 99503
Fax: (907) 564-3789

The ODPCP follows the Alaska Department of Environmental Conservation (ADEC) ODPCP requirements of Title 18, Alaska Administrative Code Chapter 75, Part 425 (18 AAC 75.425). The ODPCP addresses federal regulations in Appendix C (U.S. Environmental Protection Agency [EPA], U.S. Department of Transportation [DOT], and U.S. Coast Guard [USCG]), based on the Oil Pollution Act of 1990 (OPA 90), and EPA Spill Prevention, Control, and Countermeasure (SPCC) regulations under 40 CFR 112.

This ODPCP relies heavily upon information provided in the Alaska Clean Seas (ACS) *Technical Manual*. Information in the *ACS Technical Manual* is not repeated in this ODPCP. On each page of this ODPCP, the right margin contains references to specific tactic descriptions, maps, and Incident Management Team (IMT) information from the *ACS Technical Manual*. This format minimizes duplication.

The terms "oil" and "condensate" are used inter-changeably in this ODPCP.

ODPCP DISTRIBUTION AND UPDATING PROCEDURES

This ODPCP will be accessible to ExxonMobil employees and contractors. Hard copies of the ODPCP will be distributed to regulatory agencies and emergency operations centers. Additional copies will be located in the Anchorage office of ExxonMobil and at ACS Base in Deadhorse. A record of ODPCP distribution will be maintained at the Anchorage office of ExxonMobil.

UPDATING PROCEDURES

The ODPCP will be reviewed and updated when substantive changes occur. Per SPCC requirements, the ODPCP will also be reviewed on an annual basis and recertified every 5 years. Below is a list of key factors that may cause revisions to the ODPCP:

- New developments,
- New pipeline construction,
- Changes to response planning standards,
- Change in transported commodities,
- Change in oil spill response organizations,
- Change in Qualified Individual,
- Changes in the National Contingency Plan (NCP) or Area Contingency Plan (ACP) that have a significant impact on the appropriateness of response equipment or response strategies,

- Change in response procedures, or
- Change in ownership.

Routine updates will be submitted for ADEC review within 5 days after the date of the proposed change. Routine updates will be limited to revisions of personnel, training and other miscellaneous changes that do not affect the ability to respond to a spill. Other modifications to the ODPCP will be considered amendments and must be approved by ADEC. Proposed ODPCP revisions will be submitted within 30 days of revising the ODPCP.

Revisions will be available for ExxonMobil employee and contractor reference. Upon receipt of revisions, the recipient will replace pages as instructed. This process will indicate the completeness of the ODPCP since revisions will be consecutively numbered. It will be the responsibility of each ODPCP holder to ensure that updates are promptly incorporated into the ODPCP.

ODPCP RENEWAL

The approvals covered by this ODPCP and their renewal cycles will be as follows:

<u>Approving Agency</u>	<u>Period</u>	<u>Expiration Date</u>
Alaska Department of Environmental Conservation	5 years	
U.S. Environmental Protection Agency Facility Response Plan (FRP)	5 years	
U.S. Department of Transportation	5 years	
U.S. Coast Guard	5 years	

The ODPCP will be submitted for renewal to the approving agencies every five years, based on the ADEC five-year renewal schedule.

The operator will review the ODPCP annually to comply with USCG regulations.

1. RESPONSE ACTION PLAN

[18 AAC 75.425(e)(1)]

1.1 EMERGENCY ACTION CHECKLIST [18 AAC 75.425(e)(1)(A)]

1.1.1 Operator and Contacts

The operator covered by this plan is:

ExxonMobil
P.O. Box 196601
Anchorage, AK 99519
(907) 561-5331

Street Address:
3301 C Street, Suite 400
Anchorage, AK 99503
Fax: (907) 564-3789

For additional information contact Larry Harms, Regulatory Manager, (907) 564-3779.

1.1.2 Response Levels

A spill response operation on the North Slope falls into one of three categories:

- Level I: Small operational spill dealt with by on-scene personnel and equipment,
- Level II: Larger spill which could affect the area around the facility or operation and that uses equipment and/or trained personnel from the other operating areas of the North Slope, or
- Level III: A major spill response using resources from off the North Slope.

The Safety, Health and Environment (SHE) Lead or designated ACS Technician will assume the role of Incident Commander for a Level I incident. The Drilling Supervisor will serve as the Initial Incident Commander in a Level II/III incident involving a drilling-related incident, until relieved. During the construction phase, the Construction Site Superintendent will act as the Initial Incident Commander in a Level II/III incident. The Production Field Superintendent will act as the Initial Incident Commander in a post-construction Level II/III incident. The Incident Commander or designee will be responsible for making sure that safety is considered in response decisions and that internal notifications are completed.

Level II and III spills may involve activation of the IMT, the North Slope Spill Response Team (NSSRT), and the ExxonMobil North American Regional Response Team (NARRT). As necessary, ExxonMobil will use the resources of other North Slope operators through ACS, Mutual Aid, spill response cooperatives, and contractors.

The Point Thomson IMT response organization structure described in this plan is based on the Incident Command System (ICS) and is described in ACS *Technical Manual, Volume 3, Incident Management System*.

If all or part of the IMT is activated, the Incident Commander will be responsible for directing the organization's efforts from the Command Post at Point Thomson or the Emergency Operations Center in Anchorage. In the initial stage of a spill emergency, the Incident Commander will:

ACS
Technical
Manual,
Volume 3

- Contact ACS to request ACS equipment support.
- Consult with the On-Site Incident Commander or on-site response team members, as appropriate, on the present status of the spill (continuing or controlled), the volume of the spill, and the status of containment and cleanup efforts.
- Consult with appropriate regulatory agencies.
- Consult with the Federal On-Scene Coordinator (FOSC; either USCG or EPA) on conditions affecting slick movement.
- Identify specific equipment and personnel needs.
- Facilitate the acquisition and provision of equipment, personnel, and other resources to respond to the spill.
- Establish a Command Post at Point Thomson.
- Establish and maintain necessary radio, telephone, and communication facilities at the Command Post.

The Incident Commander will be in charge of the on-site IMT personnel in the event of a major spill. The Incident Commander has the authority to commit ExxonMobil and contractor resources available in the area to contain and cleanup oil spills. Additionally, the Incident Commander will be responsible for overall site management, including the following:

- Establishing response priorities and determining how the response will be implemented.
- Establishing the Command Post.
- Coordinating well control activities.
- Authorizing contract labor, equipment, and support services.
- Approving oil spill containment and cleanup procedures.
- Agency notification and liaison (in the absence of the SHE Lead).
- Authorizing response team personnel to request permits for burning, dispersant application, and shoreline response techniques.
- Informing ExxonMobil management about response activities.

The IMT is organized and staffed to conduct a major oil spill response operation. Personnel on the IMT have appropriate training and work experience to provide guidance and make decisions essential for ensuring that oil spills, regardless of size and location, are cleaned up in accordance with procedures that are environmentally acceptable. Also, personnel filling these positions are familiar with oil spill response techniques for use in the Beaufort Sea area.

Specific Information for a Well Event

If a well control-related spill is detected, the first priority will be to determine the source of the spill and, if possible, to shut it off immediately and then notify the Drilling Supervisor as soon as possible. In the event of an oil spill, the Drilling Supervisor has the authority and responsibility to take appropriate response actions and notify ExxonMobil management.

ExxonMobil has assigned responsibilities and provided authority to response team members to implement response actions in the event of a spill or blowout. The Drilling Supervisor will be the on-site authority during drilling operations and will be responsible for initially directing the Point Thomson Spill Response Team (SRT) and well control activities. The Drilling Supervisor will also be responsible for ensuring that the Drilling Operations Superintendent is promptly notified of spills. In the event of a blowout in which liquid hydrocarbons could lead to a major spill, the Drilling Supervisor, at his discretion, will have the authority to ignite the blowout as a means of source control and personnel safety.

The Drilling Supervisor will be responsible for directing immediate response using personnel, equipment, and on-site materials for spills at all levels. In a major spill event, Level II or III, the Drilling Supervisor will be responsible for field operations as the Incident Commander until relieved by the Drilling Operations Superintendent. He will specifically be responsible for:

- Initiating immediate actions to safeguard personnel, minimize environmental damage, and protect property.
- Notifying production personnel to shut in all wells on the affected pad.
- Assessing the situation to permit an effective first response, including immediate voluntary ignition.
- Notifying the Drilling Operations Superintendent of the situation and recommending a higher level response, if necessary.
- Planning and directing further response actions using available on-site resources.
- Authorizing mobilization of additional resources.
- Notifying government agencies in the absence of the Drilling Operations Superintendent, or if instructed to do so.

Note that ExxonMobil has provided the authority for igniting the blowout to the Drilling Supervisor. Approval of this ODPCP by the State of Alaska constitutes endorsement and pre-approval of voluntary ignition for source control.

The Drilling Operations Superintendent, based in Anchorage, has primary responsibility for Incident Command and calling out the IMT.

The Drilling Operations Superintendent will make the following decisions in a Level II or III response as quickly as possible:

- In the event of a blowout, how best to initiate forward actions, including surface intervention alternatives, assistance from specialists, relief well planning, etc.
- Whether to initiate procedures to obtain approval for the use of *in situ* burning (ISB) or chemical agents.
- Whether to request equipment from sources other than ACS.

These decisions will be made on the basis of information provided by the Drilling Supervisor and will be sensitive to the need to act decisively in order to maximize the protection of the environment.

The Drilling Supervisor will direct operations at the site to bring the well under control by surface techniques. This may entail:

- Working with the Incident Commander and well control specialists to assess well and rig equipment conditions for applicability of surface control techniques.
- Implementing well ignition procedure, if the situation escalates.
- Maintaining communications with the Incident Commander throughout the operation and providing progress reports.
- Informing the Logistics Section Chief of personnel, equipment, and supply requirements.
- Documenting actions related to well control.

1.2 REPORTING AND NOTIFICATION [18 AAC 75.425(e)(1)(B)]

1.2.1 Internal Notification Procedures

It is ExxonMobil policy for employees and contractors to report spills of oil, regardless of size, to an ExxonMobil representative. The spill observer will report a spill to his/her supervisor, and if the supervisor is unavailable, to Security. Figure 1-1 shows immediate spill notifications and Figure 1-2 shows the Point Thomson IMT. Tables 1-1A and 1-1B provide checklists of the immediate response and notification actions for a spill. The primary on-site IMT members will be determined before construction begins.

ACS
*Technical
Manual,
Volume 3*

**FIGURE 1-1
IMMEDIATE SPILL NOTIFICATIONS**

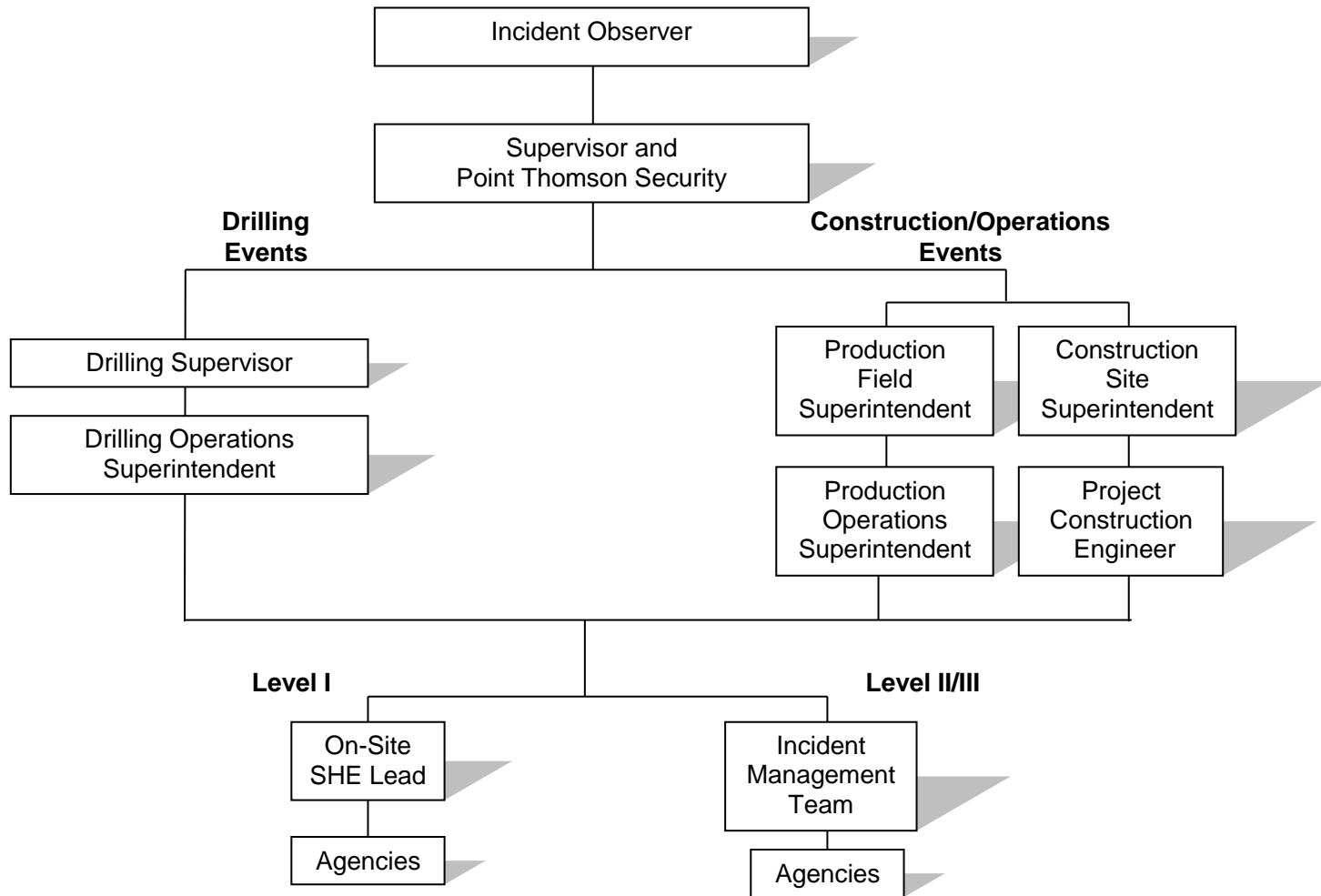

**FIGURE 1-2
POINT THOMSON INCIDENT MANAGEMENT TEAM FOR LEVEL II/III**

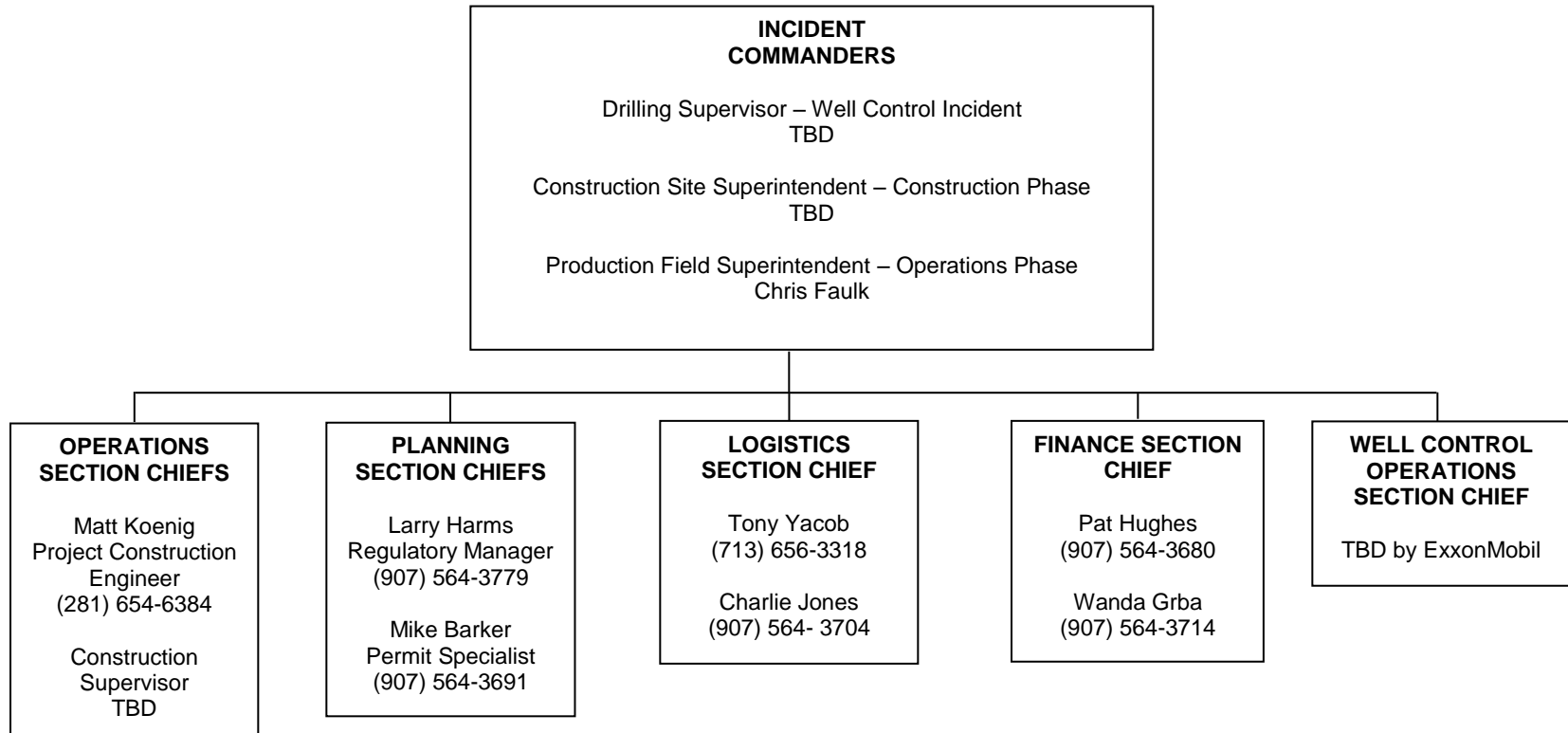

**TABLE 1-1A
IMMEDIATE ACTION CHECKLIST**

LEVEL I SPILL RESPONSE	
PERSONNEL	ACTION TO BE TAKEN
FIRST PERSON TO SEE THE SPILL	<p>Assess safety of situation, determine whether source can be stopped, and stop the source of spill if possible.</p> <p>Immediately notify supervisor and radio operator or Security.</p> <p>Dial _____ (TBD) or channel _____ (TBD) on radio.</p> <p>Provide information on:</p> <ul style="list-style-type: none"> • Personnel safety • Source of the spill • Type of product spilled • Amount spilled • Status of control operations
SECURITY	<p>Immediately notify:</p> <ul style="list-style-type: none"> • SHE Lead • Safety Coordinator • Supervisor of Drilling, Construction, or Operations
INCIDENT COMMANDER, ACS LEAD TECHNICIAN, OR SHE LEAD	<p>Report to scene, if required.</p> <p>Make an initial assessment of the spill and associated safety and environmental issues.</p> <p>Stop the source of spill, if possible.</p> <p>Initiate actions to report spill to agencies (Table 1-3). If necessary, mobilize Point Thomson SRT and on-site equipment required to control and cleanup spill.</p> <p>Upon arrival on scene, begin response operations.</p> <p>Assess response activities. If response is adequate, remain at Level I. If additional capabilities are needed, go to Level II or III response.</p> <p>Supervise control and recovery operations. Upon completion, ensure appropriate storage and disposal of oily wastes/materials.</p> <p>Confirm success of cleanup and plan remediation, if required.</p>

If the SHE Lead or ACS Lead Technician determines that the spill is a Level II or III event, the additional notifications indicated in Table 1-1B will take place.

THIS PAGE INTENTIONALLY LEFT BLANK

**TABLE 1-1B
IMMEDIATE RESPONSE AND NOTIFICATION ACTIONS**

LEVEL II OR LEVEL III SPILL RESPONSE	
SECURITY	<p>Immediately notify:</p> <ul style="list-style-type: none"> · Point Thomson SRT Lead · SHE Lead · Qualified Individual · Production Field Superintendent, Drilling Supervisor, and Construction Site Superintendent · Contractors, Personnel, and Management
SAFETY OFFICER	<p>Account for the safety of all personnel.</p> <p>Determine whether a threat of fire or explosion exists. If a threat exists, suspend control and response operations, and notify Fire/Safety Department.</p> <p>Determine appropriate personal protective equipment (PPE) and brief site workers.</p>
SHE LEAD	<p>Make immediate phone notification to the agencies.</p> <p>ACS holds permits that need to be activated.</p> <p>Prepare cleanup and waste management plan for agency approval.</p> <p>Ensure agency notifications are complete. Maintain follow-up notifications on a periodic basis and whenever there is a significant change in the course of a reported incident.</p>
INCIDENT COMMANDER, DRILLING SUPERVISOR, CONSTRUCTION SITE SUPERINTENDENT, OR PRODUCTION FIELD SUPERINTENDENT	<p>Activate all or part of the IMT and NARRT.</p> <p>Notify ExxonMobil Security at Anchorage Headquarters (HQ), (907) 561-5331. Provide Security with a contact name and phone number.</p> <p>Continue internal and external notifications.</p> <p>Coordinate staff activity.</p> <p>Manage incident operations and approve release of major resources and supplies.</p> <p>Notify production personnel to shut in all wells on the affected pad.</p>
OPERATIONS SECTION CHIEF	<p>Activate ACS, (907) 659-2405 (24 hours).</p> <p>Activate Mutual Aid through ACS, as necessary. Establish staging areas, as required.</p> <p>Provide the Logistics Section Chief with information on initial equipment, personnel, material, and supply needs.</p> <p>Supervise control and recovery operations.</p> <p>Ensure appropriate storage and disposal of oily wastes/materials.</p>
PLANNING SECTION CHIEF	<p>Ramp up Planning Section.</p> <p>Ensure agency notifications have been made and updates are provided.</p> <p>Compile and display status information in Command Post.</p> <p>Assist in development of planning process.</p> <p>Document all aspects of the response.</p> <p>Provide environmental and permitting support as needed.</p>
LOGISTICS SECTION CHIEF	<p>Order equipment, personnel, material, and supplies as requested.</p> <p>Provide transportation support.</p> <p>Provide support for field operations and Command Post operations.</p>
FINANCE SECTION CHIEF	<p>Issue cost code for tracking of expenses.</p> <p>Notify insurance representatives as warranted.</p> <p>Track expenditures and provide audit function as needed.</p>

TABLE 1-1B (CONTINUED)
IMMEDIATE RESPONSE AND NOTIFICATION ACTIONS

LEVEL II OR LEVEL III SPILL RESPONSE	
WELL CONTROL OPERATION INCIDENT COMMANDER	<p>Determine if incident requires well control specialist, and if so, contact:</p> <p>Wild Well Control, Inc.: (281) 353-5481 24-hour emergency number.</p> <p>Cudd Well Control (a Division of Cudd Pressure Control): 1-800-990-CUDD 24-hour emergency number, (713) 849-2769 world-wide number.</p> <p>Critical Well Coordinator at Prudhoe Bay (907) 659-2805.</p>
WELL CONTROL OPERATIONS SECTION CHIEF	<p>Identify well control options based on circumstances of incident.</p> <p>Notify rig contractors and coordinate activities.</p> <p>Implement logistics plan to provide support for the well control specialists.</p>

A Spill Report Form will be completed for reportable spills. See Figure 1-3 for an example.

The on-site ExxonMobil Drilling Supervisor will be notified as soon as possible of oil spills associated with Point Thomson drilling operations. The Drilling Supervisor is responsible for ensuring that the Drilling Operations Superintendent in Anchorage is promptly notified of spills. The Drilling Operations Superintendent based in Anchorage will notify the company management and advise it of the response effort and whether the spill threatens a sensitive area. He will provide management with preliminary information on the size of the spill, whether it is continuing, whether the spill is moving toward a sensitive area, and the estimated time to arrive.

The Production Field Superintendent is responsible for ensuring that the Production Operations Superintendent is promptly notified of spills associated with construction and operations. The Construction Site Superintendent at Point Thomson will report spills to the Project Construction Engineer based in Anchorage.

1.2.2 External Notification Procedures

The Incident Commander or designee is responsible for notifying the regulatory agencies of oil spills. Agency notification information is provided in Tables 1-2 and 1-3. See Section 3.3 for a description of the command system, including the Incident Commander and those members of the IMT who notify agencies.

ACS Tactic A-2

1.2.3 Qualified Individual Notification and Responsibilities

During the drilling phase, the Drilling Supervisor will be the QI, during the construction phase, the Construction Site Superintendent will be the QI and during the production phase, the Production Field Superintendent will be the QI. These individuals will be on-site during drilling, construction, and production activities.

In the event of a spill requiring notification of the Federal On-Scene Coordinator (FOSC), the QI will be notified and will respond. In the event the primary QI is unavailable, the alternate QI will respond.

The prerequisites for designation of a QI are:

- Available on a 24-hour basis,
- Speaks English fluently,
- Located in the United States,
- Trained as a qualified and alternate QI under the response plan, and
- Familiar with the emergency response plan and its implementation.

The QI will be trained in and authorized to carry out the following responsibilities:

- Activate and engage in contracting oil spill removal organizations and other response-related resources,
- Act as a liaison with the Federal On-Scene Coordinator, and
- Acquire funds to carry out response activities.

**TABLE 1-2
EXXONMOBIL CONTACT LIST**

POSITION	NAME	TELEPHONE
<u>EXXONMOBIL MANAGEMENT, HOUSTON</u>		
Point Thomson Project Manager	R. Buckley	(281) 654-4054
Point Thomson Project Construction Engineer	M. Koenig	(281) 654-6384
Field Drilling Manager	P. Altimore	(281) 654-4428
Production Operations Manager	TBD	TBD
<u>EXXONMOBIL MANAGEMENT, ANCHORAGE</u>		
Headquarters Security (24-hour)		(907) 561-5331
Alaska Interest Organization Manager	J. Williams	(907) 564-3689
Regulatory Manager	L. Harms	(907) 564-3779
Drilling Operations Superintendent	TBD	TBD
Production Operations Superintendent (Alt. QI) ¹	C. McClain	TBD
Project Construction Engineer	TBD	TBD
<u>FACILITY CONTACTS, POINT THOMSON</u>		
Security (24-hour)	TBD	TBD
Drilling Supervisor (QI) ¹	TBD	TBD
Construction Site Superintendent (QI)	TBD	TBD
Safety, Health and Environment Lead	TBD	TBD
Regulatory Compliance Group	TBD	TBD
ACS Environmental Technician	TBD	TBD
Production Field Superintendent (QI) ¹	C. Faulk	TBD
<u>WELL CONTROL SPECIALISTS</u>		
Wild Well Control, Inc. (24-hour)		(281) 353-5481
Cudd Well Control, a Division of Cudd Pressure Control (24-hour)		(800) 990-CUDD
World-Wide Number		(713) 849-2769
Critical Well Coordinator at Prudhoe Bay		(907) 659-2805
<u>ALASKA CLEAN SEAS, OSRO</u>		
Address: Pouch 340022, Prudhoe Bay, Alaska 99734		
Prudhoe Bay Office		(907) 659-2405
Operations Manager		(907) 659-3202

HQ Security will provide notification to ExxonMobil management and spill response teams on a 24-hour basis.

¹ The primary and alternate Qualified Individuals will be updated prior to construction.

THIS PAGE INTENTIONALLY LEFT BLANK

**TABLE 1-3
AGENCY REPORTING REQUIREMENTS FOR OIL SPILLS**

AGENCY	SPILL SIZE	VERBAL REPORT	PHONE NUMBERS	ALASKA CONTACT	WRITTEN REPORT
National Response Center (Notifies all appropriate federal agencies)	See specific federal agency below for guidance on reportable spill size	Immediately	(800) 424-8802 (24-hour)	24-hour line	Not required as form is completed during phone notification process
EPA	Any size to navigable waters of the U.S. (includes tundra) or to land that may threaten navigable waters	Immediately	(907) 257-1342 (M-F, 8-5) (206) 553-1263 (907) 271-3424 (FAX) (M-F, 8-5)	Carl Lautenberger Seattle office, 24-hour EPA fax number	For facility requiring SPCC Plan if spill is 1,000 gallons or more or if it is second spill in 12 months
USCG	Any size in or threatening navigable waters	Immediately	(907) 271-6700 (24-hour) (907) 271-6751 (FAX)	Marine Safety Office USCG fax number	Not required, but requested
DOT	>5 gallons ; no report required for release less than 5 barrels resulting from pipeline maintenance activity ¹	Immediately ²	(800) 424-8802	24-hour line	Required within 30 days on DOT Form 7000-1 (see form for details)
U.S. Department of the Interior, U.S. Fish and Wildlife Service (USFWS)	Any size that poses a threat to fish and wildlife	Immediately	(907) 271-2797	---	---
U.S. Department of the Interior, Minerals Management Service (MMS)	All spills into marine waters	Immediately	(907) 271-6065 (24-hour) (907) 271-6504 (FAX)	Jeff Walker	Copies of any reports submitted to ADEC as soon as possible
Pipeline Coordinators Office (State Pipeline Office [SPCO]/DOT) - Anchorage, AK	Any size from a regulated pipeline	Immediately	(907) 271-4373	---	---
ADEC, Northern Alaska Response Team	ON WATER Any Volume	Immediately	(907) 451-2121 (907) 451-2362 (FAX) and (800) 478-9300 (M-F after 5, Sat, Sun)	Ed Meggert ADEC fax number or Alaska State Troopers	Fax immediately after verbal report; a follow up report within 15 days of end of cleanup
	ON LAND 1 to 10 gallons	Within 48 hours of knowledge of the spill			Include in monthly written report; a follow-up report within 15 days of end of cleanup.
	>10 to 55 gallons	Within 48 hours of knowledge of the spill			Include in monthly written report; a follow-up report within 15 days of end of cleanup.
	>55 gallons	Immediately			Fax on same day spill occurs

**TABLE 1-3 (CONTINUED)
AGENCY REPORTING REQUIREMENTS FOR OIL SPILLS**

AGENCY	SPILL SIZE	VERBAL REPORT	PHONE NUMBERS	ALASKA CONTACT	WRITTEN REPORT
ADEC, Northern Alaska Response Team (Continued)	IN SECONDARY CONTAINMENT <55 gallons	None	(907) 451-2121 (907) 451-2362 (FAX) and (800) 478-9300 (M-F after 5, Sat, Sun)	Ed Meggert ADEC fax number or Alaska State Troopers	None
	>55 gallons	Within 48 hours of knowledge of the spill			None
Alaska Department of Natural Resources (ADNR)	ON LAND <1 gallon to gravel pad or road; ice pad or road	None	(907) 451-2678 (907) 451-2751 (FAX)	Spill Report Number ADNR fax number	None
	1 to 10 gallons	Within 48 hours of knowledge of the spill			None
	>10 to 55 gallons	Within 48 hours of knowledge of the spill			None
	>55 gallons	Immediately			None
	IN SECONDARY CONTAINMENT <55 gallons	None			None
	>55 gallons	Within 48 hours of knowledge of the spill			None
Alaska Oil and Gas Conservation Commission (AOGCC)	All spills from wells or involving any crude loss	Immediately	(907) 279-1433 (24-hour) 276-7542 (FAX) (907) 659-3607 659-2717 (FAX)	Sarah Palin	Within 5 days of loss

**TABLE 1-3 (CONTINUED)
AGENCY REPORTING REQUIREMENTS FOR OIL SPILLS**

AGENCY	SPILL SIZE	VERBAL REPORT	PHONE NUMBERS	ALASKA CONTACT	WRITTEN REPORT
North Slope Borough (NSB)	ON WATER Any Volume	Immediately	(907) 852-0440 (Barrow) (907) 852-0322 (FAX) (907) 852-0284 (Local Emergency Planning Committee [LEPC]-Barrow) (907) 852-6111 or (907) 852-2995 (NSB police-Barrow) (907) 428-7000 (State Emergency Planning Committee [SEPC]-Anchorage)	Permitting and Zoning Dept. Waska Williams, Office of Safety and Environmental Affairs (OSEA)	None
	ON LAND (gravel pad or road; ice pad or road; snow- covered tundra) >55 gallons	Immediately			None
	IN SECONDARY CONTAINMENT >55 gallons	Within 48 hours of knowledge of the spill			None

1. No report is required for a release less than 5 barrels resulting from a pipeline maintenance activity, if the release:

- Is not otherwise reportable;
- Did not result in pollution of any stream, river, lake, reservoir, or other similar body of water that violated applicable water quality standards, caused a discoloration of the surface of the water or adjoining shoreline, or deposited a sludge or emulsion beneath the surface of the water or upon adjoining shorelines; and
- Is confined to company property or pipeline right-of-way AND cleaned up promptly.

2. The operator shall give verbal notice if the release:

- Caused a death or personal injury requiring hospitalization;
- Resulted in either a fire or explosion not intentionally set by the operator;
- Caused estimated property damage, including cost of cleanup and recovery, value of lost product, and damage to the property of the operator and/or others exceeding \$50,000;
- Resulted in pollution of any stream, river, lake, reservoir, or other similar body of water that violated applicable water quality standards, caused a discoloration of the surface of the water or adjoining shoreline, or deposited a sludge or emulsion beneath the surface of the water or upon adjoining shorelines; or
- Was significant in the operator's judgment even though it did not meet the criteria.

1.2.4 Written Reporting Requirements [18 AAC 75.300]

Depending on the type and amount of material spilled, individual government agencies have written reporting requirements that must be adhered to by ExxonMobil.

Regulation 18 AAC 75.300 requires notification to ADEC of spills on state lands or waterways. After notification of the discharge has been made to ADEC, the Department will, at its discretion, require interim reports until cleanup has been completed. A written final report must be submitted within 15 days of the end of cleanup operations, or if no cleanup occurs, within 15 days of the discharge. ExxonMobil's interim and final written reports will meet the requirements that are specified in 18 AAC 75.300 and will contain the following information:

- Date and time of discharge;
- Location of discharge;
- Name of facility or vessel;
- Name, mailing address, and telephone number of person or persons causing or responsible for the discharge and the owner and the operator of the facility or vessel;
- Type and amount of each hazardous substance discharged;
- Cause of the discharge;
- Description of any environmental damage caused by the discharge or containment to the extent the damage can be identified;
- Description of cleanup actions taken;
- Estimated amount of hazardous substance cleaned up and hazardous waste generated;
- Date, location, and method of ultimate disposal of the hazardous substance cleaned up;
- Description of actions being taken to prevent recurrence of the discharge; and
- Other information the Department requires to fully assess the cause and impact of the discharge.

USDOT and USEPA notification and reporting procedures will also be followed in the event of a discharge. See Table 1-3.

1.3 SAFETY [18 AAC 75.425(e)(1)(C)]

The principal sources of information concerning safety procedures and practices to be followed in the event of a spill are:

- *ACS Technical Manual* includes site entry procedures, site safety plan development, and personnel protection procedures.
- *Alaska Safety Handbook* distributed to all North Slope employees and contractors.
- *ExxonMobil Production Safety Manual*.

ACS Tactics S-1 through S-6

- ExxonMobil *Emergency Response Guide* written to aid in responding to events or situations that might arise from ExxonMobil activities or operations that pose, or could pose, a threat to the safety and welfare of people, the environment, ExxonMobil assets, or others.

Evacuation plans will be maintained on-site at the Point Thomson facility.

1.4 COMMUNICATIONS [18 AAC 75.425(e)(1)(D)]

ExxonMobil's Point Thomson communications are designed for compatibility with the communications equipment available through ExxonMobil's Anchorage office and ACS's North Slope Emergency Response Communication Network. Initially, Point Thomson will respond using the day-to-day communications system.

The frequencies assigned to Point Thomson are as follows:

- To be determined prior to construction activities.
- To be determined prior to construction activities.

During drilling and construction, a C-band satellite Earth station will provide standard voice (telephony) and data capabilities to/from the Point Thomson field location and Deadhorse, as well as to locations external to the North Slope region. A single-site VHF/UHF repeater system will also be provided at the Point Thomson field location to provide local Company radio traffic as well as Contractor construction activities, VHF marine, and ACS oil-spill response communications. These radio systems will facilitate two-way communications between vehicles and personnel in and around the drill site. The UHF (Company-operated) equipment located at the drill site will consist of a base station and a minimum of four rechargeable hand-held portable radios. At least four additional portable units are available at Deadhorse. The spare units can be quickly mobilized to the drill site by air or, during the first two years, by ice road. The stand-alone VHF ACS oil-spill response equipment will consist of a base station and a minimum of four rechargeable hand-held portable radios and two mobile units.

Prior to Point Thomson tie-in to the ACS Wide Area Radio System (via the planned Point Thomson – Deadhorse microwave system), the Badami ACS oil spill repeater and coast station will be used for spill response communications as needed. In the event of a spill at or near the Point Thomson location, additional UHF repeaters would be installed on the existing Badami tower (by ACS) pointing easterly in the direction of Point Thomson. These UHF repeaters will be capable of remote control by the ACS Centracom dispatch console at Deadhorse via the existing Badami – Deadhorse microwave connection. ACS would then extend coverage from Badami by setting up portable shelters and repeaters along the spill route. The stand-alone VHF ACS oil-spill response equipment installed at Point Thomson would act as a supplementary radio system to the existing Badami ACS oil-spill response system.

At Point Thomson, an ACS wooden console (VHF base, UHF base, and VHF Marine Base), pipemounts and roof antennas will be installed after power generators are installed at the central facility.

Before production startup, an oil spill repeater system (OS-45) with antenna will be installed on the Point Thomson facility tower. Two single-channel remote controls will be installed in

association with this repeater system. After installation and commissioning of the planned Point Thomson – Deadhorse microwave system, the Point Thomson oil spill repeater system will be connected to the ACS Slope-wide radio system (via the Point Thomson – Deadhorse microwave system). The control point for the system is the ACS Base in Deadhorse.

Also for production startup, a marine private coast station (Marine Channel 9) with an antenna on the Point Thomson tower will be installed in the facility. They will be connected to ACS Base in a manner similar to the oil spill repeater.

In addition, the following equipment will be available at Point Thomson for oil spill response: Ten Motorola VHF hand-held radios with speaker microphones, spare batteries and individual and multi-chargers, two Motorola VHF mobile radios, two hand-held global positioning system (GPS) units and two bagphone cellular phones.

A cell site repeater at the Point Thomson facility will be obtained through Arctic Slope Telephone.

The Point Thomson VHF repeater provides for a direct tie-in to the ACS communications system. With such repeaters installed across the North Slope, coverage is provided from Alpine to Point Thomson. The range of each fixed repeater is approximately 30 to 50 miles, depending on topography. ACS solar-powered or generator-powered portable repeaters can also be deployed at the time of a spill. ACS will provide the repeater, coast station, antennas, hand-held radios, and backboarded mobiles to allow for effective spill response, when necessary in an emergency.

Where required, the self-contained ACS communications module will be mobilized for use by ExxonMobil. The ACS Mobile Command Center and the Staging Area Manager's office are equipped with various radio, bush phone, and microwave equipment to provide communications to the field. This capability coordinates the NSSRT with the *North Slope Operating Area Frequency Plan*, and includes access to mobile communication channels.

A detailed explanation of oil spill communications on the North Slope is provided in the ACS *Technical Manual*.

ACS Tactic
L-5

1.5 DEPLOYMENT STRATEGIES [18 AAC 75.425(e)(1)(E)]

1.5.1 Transport Procedures [18 AAC 75.425(e)(1)(E)(i)]

Procedures for initial transportation of equipment and personnel to the spill site rely on equipment based at Point Thomson and at other North Slope facilities. Transportation options vary with the season and other factors.

The general alternatives and estimated travel times are listed in Tactics L-3 and L-4 of the ACS *Technical Manual*. Actual transportation times vary with weather, safety considerations, wildlife considerations, and terrain. Illustrations of transportation strategies are found in the scenarios in Section 1.6.14.

ACS
Tactics
L-3 and L-4

Estimated travel times for initial responses to oil spills at Point Thomson are listed below:

- Central Processing Facility (CPF): 10 minutes.
- Production well pads by vehicle from CPF: 1/4 - 1/2 hour.
- Production well pads by vehicle on ice road from Prudhoe Bay: 2 hours.

- Condensate export pipeline by helicopter (when available): 1/2 hour.
- Condensate export pipeline by Rolligon (when available) and all-terrain vehicles (ATVs): 5 hours.
- Point Thomson dock from West Dock by vessel: 9 hours.
- CPF from Deadhorse by fixed-wing aircraft (when available): 1/2 hour.

The wide variety of transportation modes provides alternatives in adverse weather conditions. Rolligons, helicopters, and fixed-wing aircraft are options for transportation in all seasons. Vehicles are options for reaching Point Thomson during the two winter seasons in which an ice road links the road system to Point Thomson. Vessels are options from July to October. See Figure 1-4.

When poor visibility and icing conditions limit air transportation and the use of landing strips, ground and vessel transportation provide alternatives depending on the season. Low temperatures and wind do not directly affect land transportation options. White-out conditions affect air and land transportation options similarly.

1.5.2 Notification and Mobilization of Response Action Contractor [18 AAC 75.425(e)(1)(E)(ii)]

ACS is the primary response action contractor. The 24-hour phone number for ACS is listed in Table 1-2.

Sections 1.1 and 1.2 describe immediate response and notification actions, which include notification of ACS. While ACS is mobilizing personnel and equipment to the spill site, ExxonMobil personnel will determine safety procedures, notify government agencies and additional ExxonMobil personnel, and proceed with source control measures. In addition, if safe to do so, response personnel will deploy on-site spill containment equipment.

1.6 RESPONSE STRATEGIES [18 AAC 75.425(e)(1)(F)]

1.6.1 Procedures to Stop Discharge [18 AAC 75.425(e)(1)(F)(i)]

Module Shutdown

Safety Instrumented Systems (SIS), independent of the Process Control System (PCS), will serve to protect equipment and personnel from process upset and emergency conditions. In the event the PCS fails to keep the process within specified operating limits, these dedicated safety systems will provide for the safe shutdown of equipment and process units. The safety systems will include dedicated process sensors that activate dedicated output devices and do not rely on functions controlled by the PCS.

These safety systems, while functioning separately, will have data links to the PCS for purposes of monitoring and activating the safety functions from the Central Control Room (CCR) panels. Additional switches will be provided in proximity to the protected systems for activation of shutdown by personnel in the field.

**FIGURE 1-4
SURFACE TRANSPORT SEASONS**

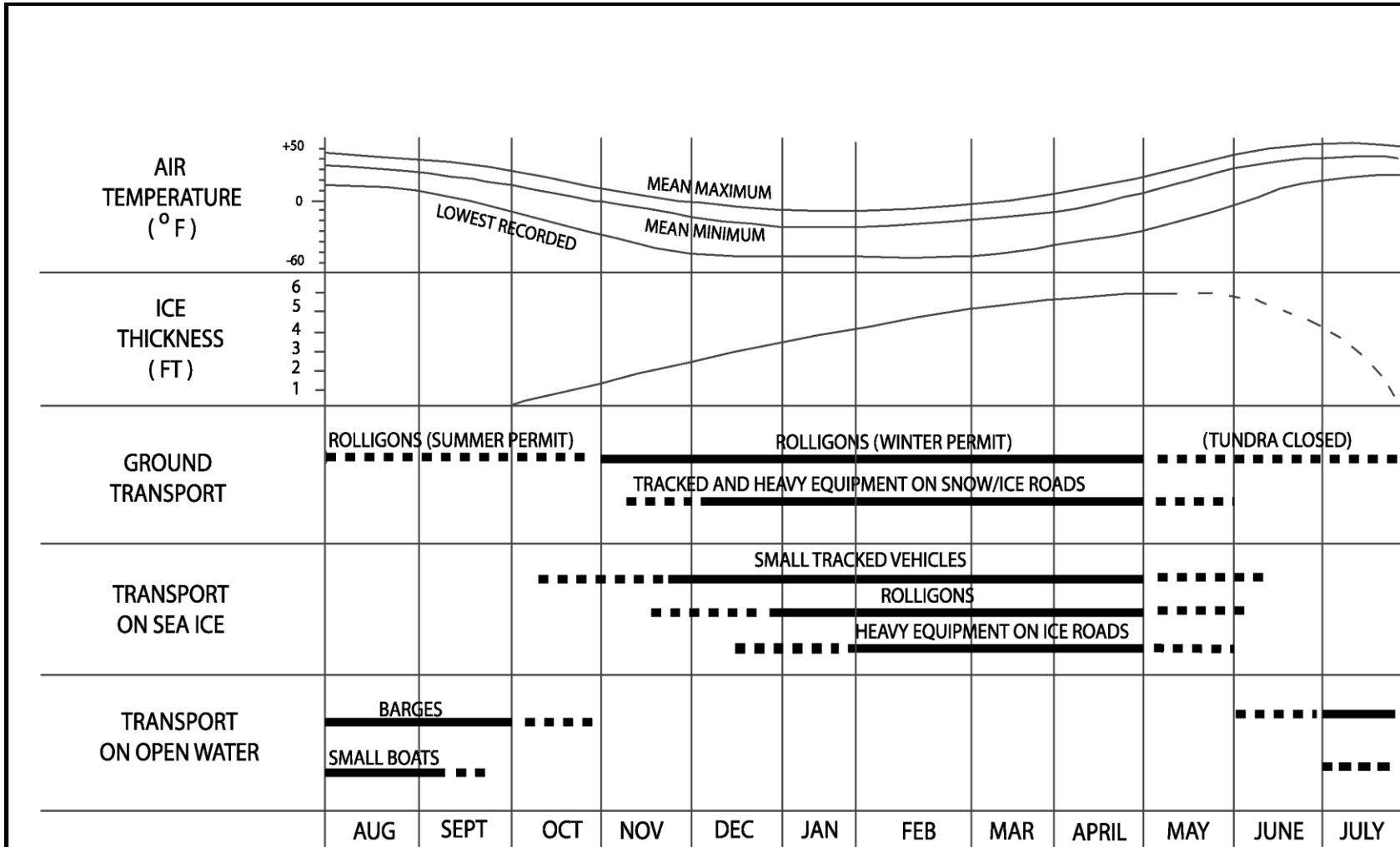

In order of priority, the purposes of the safety systems are to:

- Protect personnel from an abnormal condition,
- Protect the environment,
- Protect equipment from damage, and
- Safely isolate problem areas to allow production to continue, if possible.

There will be a minimum of three levels of shutdown at the Point Thomson facilities as follows:

- **Process Shutdown (PSD).** Process systems are isolated during a PSD either by critical process variable alarms or operator action. PSDs are segregated by process systems such as the production wells, condensate processing train, condensate stabilization, condensate shipping, flash-gas compression, high-pressure gas injection compression, gas injection wells, and produced water handling. A PSD isolates the specific process system while the remaining process systems either remain on-line, or are brought to a safe condition automatically or by operator action.
- **Emergency Shutdown (ESD).** An ESD isolates the entire CPF processing system while maintaining operation of the utility and safety systems. An ESD is activated either by critical process alarms, fire or gas detection alarm, or by operator action. The ESD will isolate the well pads and production streams entering the plant, and the condensate export system leaving the plant, and will depressurize the isolated section where the incident is detected. If possible, the gas injection wells will remain on-line to maintain a supply of gas for the fuel gas system and the process systems will remain at pressure. Freeze protection procedures will be initiated if the shutdown is expected to be for an extended period of time. All utility systems will remain on-line to ensure safe plant shutdown and to maintain life support systems.
- **Total Plant Shutdown (TPS).** Following an ESD, if it is determined that the field is to be shut down, a TPS is initiated. If the field is to be restarted in the near term, the freeze protection operations will be completed before initiating the TPS. If the TPS is the result of an emergency, all the process systems are depressurized to the flare with the last system depressurized being the fuel gas system and the gas injection lines from the central injection pad. In either case, the normal power generation system is isolated while the essential power generator is brought on-line. During the TPS, utility systems are isolated and shut down either automatically or by operator intervention, as dictated by the severity of the emergency event and the rapidity of the intervention required to ensure a safe and orderly response.

Condensate Handling System

In an ESD, all hydrocarbon lines entering and leaving the plant will be shut in, wells will be shut in to prevent overpressure of the pipelines, and the first-stage separator, pumps, and motors will be turned off.

Well Pads and Manifolds

The well shut-in will be automated and response times kept at a minimum. The design of the well shut-in system follows the shutdown philosophy discussed below.

The Point Thomson wells will have a master “Christmas tree” surface safety valve (SSV) that is hydraulically actuated, an SSV on the well-line wing, and a surface-controlled subsurface safety valve (SSSV) that can shut in the well. The SIS for the wellheads will actuate these valves in the event of a shutdown, and the valves will shut and wells will cease producing. The SSVs are a “fail closed” design (loss of hydraulic pressure results in the closing of the SSVs). Two manual valves on the tree can be closed by Operations personnel to provide further isolation. Lines connecting producing wells at Point Thomson will be equipped with low-pressure sensors used to isolate producing wells in the event of a leak. If the pressure in a line drops below a set limit, the line will shut in. Operations personnel performing routine checks would identify small leaks that would not activate the low-pressure sensor. If a small leak is identified, manual steps will be taken immediately by Operations personnel to isolate the leak.

Maintenance of Shutdown Systems

Systems will receive periodic testing and maintenance. Provisions are made to deactivate the shutdown system while testing and maintenance are in progress.

Pipeline

Isolation valves can be activated to minimize discharge from the condensate export pipeline. The control room operator, under the direction of the Operations Team Leader, can initiate a pipeline ESD to close the automated main outlet valve. The pipeline ESD will automatically close valves. The control room operator can then verify valve closure of the isolation valves with a distributed control system (DCS) indication.

1.6.2 Fire Prevention and Control [18 AAC 75.425(e)(1)(F)(ii)]

Each module will be equipped with fire and gas detectors at various locations within the module. The type and number of fire and gas detection devices will vary from module to module, depending on the service of the equipment in the module. The systems will be electrically supervised against short- and open-wiring faults in the detection and alarm circuits. The electrical power supply is supported by the uninterruptible power system.

Fire Detection System

Fire detection systems in process facilities will use infrared (IR) flame detectors which detect the infrared radiation produced by a fire. Triple IR technology will be used, which uses programmed algorithms to correlate the data received by three sensors within each detector. The electrical power supply will be supported by an uninterruptible power supply (UPS).

Gas Detection System

Gas detection systems in process facilities are generally integrated as a part of the SIS. The electrical power supply will be supported by a UPS. The gas detection equipment will be selected to identify the concentration of a particular gas, which closely aligns with the composition of any potential gaseous leaks.

Generally, if a gas concentration above an established low level (generally 10 to 20 percent of the lower explosive limit [LEL]) is detected by a gas detector, area ventilation will be stepped-up from low speed (typically 6 air changes per hour) to high speed (typically 12 air

changes per hour), and alarms will be sounded in the module and the CCR. If one or more gas heads are detected above an established high level (generally 40 to 60 percent), multiple alarms will activate and the process systems in the area will be isolated and blown down.

Automated Methods

Fire detection and alarms will be controlled by a control panel or a dedicated computer system. The automated systems will be responsible for monitoring the fire alarm detection systems within the field of operation.

Alarms Initiated by Detectors

The ICSS will receive alarms from fire and gas controls and annunciate alarm status. The alarms will light up and sound, as appropriate, in the CCR and the affected areas. Examples of alarms that the DCS will receive are high or low gas alarms and fire alarms.

Response to Alarm Signals from Detectors

Personnel will respond to alarms by locating the alarm point and identifying whether the alarm represents a true condition. Personnel safety is the first priority throughout this process.

The fire detection systems will automatically initiate fire suppression release where suppression systems are installed, and isolate and blow down the process systems located in the area.

Manual Bypass of Automated Systems

Technicians who test and perform maintenance on the sensory equipment will first isolate the discharge circuit to prevent the accidental release of fire suppression. Board Operators will receive an alarm indicating the system has been bypassed.

Once the manual fire suppression by pass panel is active, the following will occur:

- The system by pass is entered on the defeated safety device log,
- Fire alarms will not cause a fire suppression dump,
- Electric pull stations will not release fire suppression, and
- If a fire suppression release condition should occur during a system by pass, the operators will use the manual fire suppression dump mechanism.

The defeated (by passed) Safety Devices Standard/Procedure is a critical operating procedure outlined in ExxonMobil's Operations Integrity Management System (OIMS) that establishes a procedure to authorize, record, and monitor all defeated safety devices by means of a master log called a Defeated Safety Device Log.

After any fire suppression system by pass, a system of work permits and other administrative controls specify the requirements for reactivating the system and will ensure the system is not left disabled.

Visual Detection of Fires

If equipment fires occur outside the range of automated detection systems, and are detected visually, there will be two methods of notification as follows:

- Manual fire alarms can be activated to initiate the automated systems and response activity.
- Fires can be reported to the CCR by calling the designated emergency number. A red phone specifically dedicated for incoming emergency calls is reached by dialing an assigned code, such as 911 or 000. Communications will activate the response teams.

1.6.3 Blowout Response [18 AAC 75.425(e)(1)(F)(iii)]

ExxonMobil considers surface intervention, supplemented with voluntary well ignition in the event of unrestricted flow, represents Best Available Technology (BAT) for well source control during exploration or production well blowouts. However, provisions for drilling a relief well are maintained as required by 18 AAC 75.455(d)(2). The general logic regarding response to a surface blowout is described in Figure 1-5A, and Figure 1-5B shows the Well Ignition Decision Tree.

If well control is lost, resulting in an uncontrolled flow of fluids at the surface, detailed planning will begin in order to regain control. A thorough evaluation of the situation will be necessary to determine the best course of action. There are three primary considerations in developing a blowout response plan, based on the specific well conditions, as follows:

- Access to the well/site that ensures personnel safety;
- Well status, including the location of the release and whether ignition has occurred; and
- The best method for quickly regaining well control and minimizing pollution.

See Table 1-4 for Drilling Supervisor actions.

Blowout Well Ignition

Because ignition of the well may be necessary to facilitate safety during surface intervention and control activities, or to minimize environmental impact, ExxonMobil may elect to voluntarily ignite the blowout at the well.

The decision by ExxonMobil to voluntarily ignite a blowout (except for immediate concerns with ensuring personnel safety) will be made after assessing the probability of implementing successful surface control, reviewing potential safety hazards, and addressing pertinent environmental considerations.

Table 1-5 outlines well ignition procedures and lists the well ignition equipment that will be stored at Point Thomson.

**FIGURE 1-5A
GENERAL SURFACE INTERVENTION OPTIONS**

ExxonMobil

**OIL DISCHARGE PREVENTION AND CONTINGENCY PLAN
POINT THOMSON
MAY 2003
PREAPPLICATION DRAFT**

ExxonMobil

**OIL DISCHARGE PREVENTION AND CONTINGENCY PLAN
POINT THOMSON
MAY 2003
PREAPPLICATION DRAFT**

ExxonMobil

**OIL DISCHARGE PREVENTION AND CONTINGENCY PLAN
POINT THOMSON
MAY 2003
PREAPPLICATION DRAFT**

**FIGURE 1-5A
GENERAL SURFACE INTERVENTION OPTIONS**

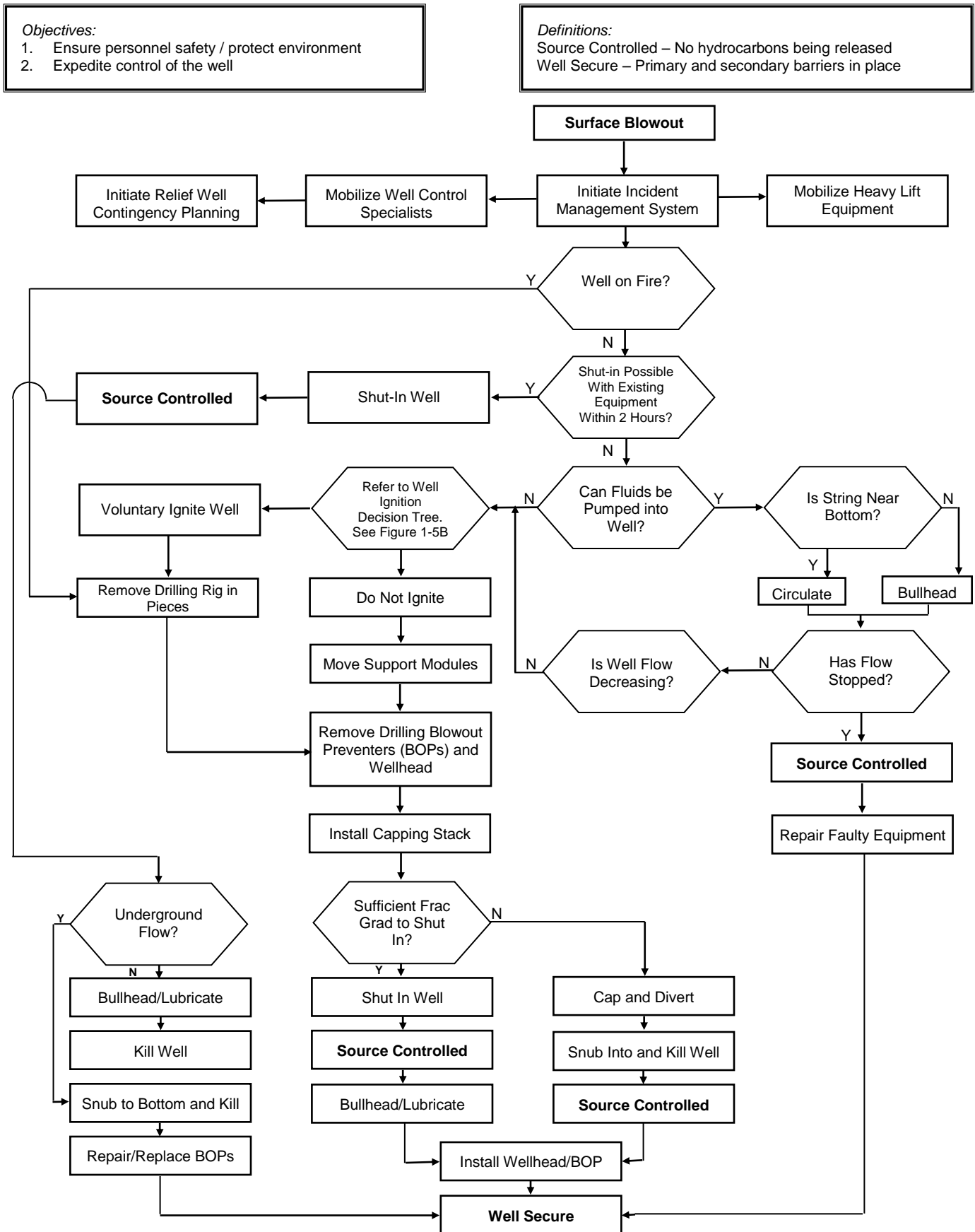
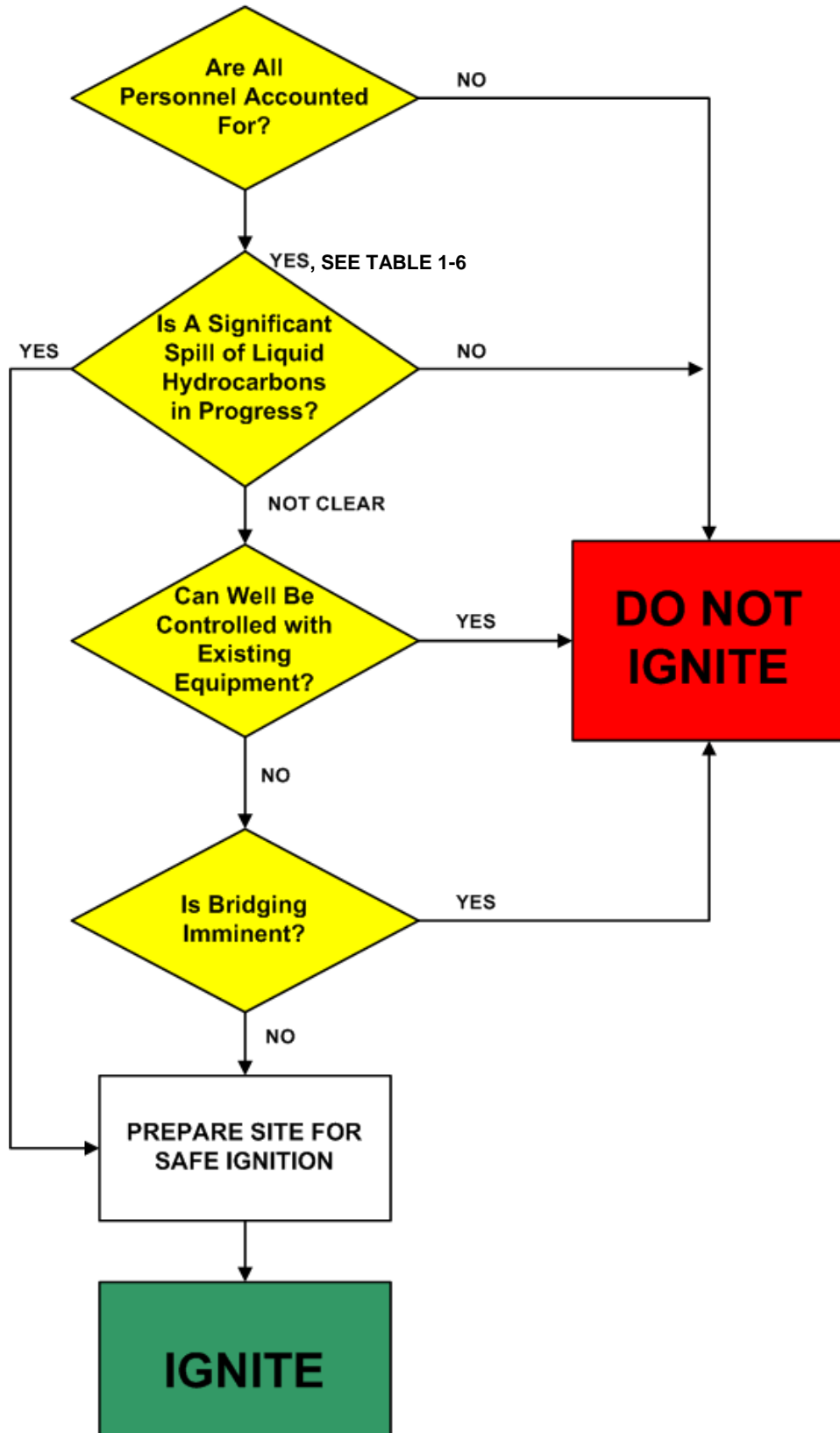

FIGURE 1-5B
WELL IGNITION DECISION TREE



**TABLE 1-4
DRILLING SUPERVISOR CHECKLIST FOR IMMEDIATE BLOWOUT RESPONSE**

PERSONNEL	<ol style="list-style-type: none"> 1. Activate alarms and evacuate hazardous areas, assemble in predesignated area, take roll call. 2. Search for missing personnel if safe to do so. If gas is present, use the buddy system, breathing apparatus, and combustible gas detectors. 3. Administer first aid and arrange for evacuation of injured personnel. 4. Arrange transport of personnel to remote, safe area if situation requires.
WELL CONTROL	<ol style="list-style-type: none"> 1. Extinguish all ignition sources. 2. Make preliminary well condition assessment: whether the well is burning, danger of ignition, type of fluid, approximate rate, location of flow, wellhead and BOP integrity, status of rig equipment, etc. 3. Initiate immediate well control actions judged to be safe and practical with the resources on location. 4. Notify the production supervisor to shut in all wells on the affected pad.
EQUIPMENT	Move response equipment and vehicles a safe distance from the well for later use in control and cleanup efforts.
OIL SPILL COUNTERMEASURE	<ol style="list-style-type: none"> 1. Divert oil flow away from quarters and rig equipment. 2. Notify the production supervisor to shut in all wells on the affected pad.
REPORTING	As soon as practical, notify the Drilling Operations Superintendent. A Spill Report and a Well Control Emergency Report form should be completed as soon as practical and sent by facsimile to the Drilling Operations Superintendent.

**TABLE 1-5
EMERGENCY WELL IGNITION PROCEDURES**

EQUIPMENT	<ol style="list-style-type: none"> 1. Explosimeter/gas detector (2), and spare batteries 2. Self-contained breathing apparatus (2) 3. 500-foot lengths of safety retrieval rope (2) 4. Meteor-type flare gun (1), and spare flare
PROCEDURE	<ol style="list-style-type: none"> 1. Evacuate all personnel to a safe distance upwind from the well. To avoid a major explosion, well ignition should not be attempted unless the wind speed is a minimum of 5 miles per hour (mph). 2. The ignition team consists of (a) two personnel wearing breathing apparatus with body harnesses; and (b) personnel to tend the ropes and pull either person to safety if he is overcome by fumes. 3. Select a firing point and approach route that is upwind, no closer than necessary to the blowing well, and affords the greatest degree of protection and accessibility. 4. One person is responsible for monitoring the explosimeter and the other is responsible for firing the flare. 5. Approach the well along the upwind approach route until the explosimeter indicates the presence of combustible gas. Back up along the approach route 100 yards, and fire the flare to ignite the well. Do not fire the flare unless the explosimeter confirms that it is safe to do so.

Prior to actually igniting the well, the Drilling Supervisor would confirm that personnel are safe.

The circumstances for igniting an uncontrolled well blowout are those circumstances that the rig supervisor could readily determine at the time, and in which ignition would maintain safety and minimize environmental damage. For several potential well blowout situations, the relationship between ignition effects and safety and environmental protection thresholds have previously been clearly established. Those limited circumstances are defined in Table 1-6 as the terms for the pre-authorization for well ignition.

**TABLE 1-6
CONDITIONS FOR PRE-AUTHORIZED WELL IGNITION**

- | |
|---|
| <ol style="list-style-type: none">1. Other wells on the well pad are shut-in.2. Personnel are evacuated beyond the expected radius of collateral damage.3. Without ignition, the volume of oil reaching the surface and remaining uncontrolled is expected to exceed 100,000 gallons (2,400 barrels [bbl]). |
|---|

Time is of the essence, so a decision on voluntary ignition would be reached as soon as possible. ExxonMobil's plan would be to reach a decision within 2 hours.

Surface Control Options

In the unlikely event that well control is lost while drilling a well, every effort would be made to provide control at the surface. Historically, regaining control at the surface is fast and successful. Because an uncontrolled flow at the surface would present a safety hazard, specific safety procedures would be employed to protect personnel, the environment, and equipment.

Source control could be accomplished either through natural means or direct surface intervention. The most common natural means would be formation bridging which occurs due to wellbore collapse caused by subsurface pressure changes during the blowout.

Loss of surface control maximizes the pressure drop across the formations, which maximizes rock stress and, therefore, the probability of natural bridging. Under bridging conditions, the wellbore becomes restricted and flow at the surface decreases or ceases. While surface control could be regained through natural bridging, additional mechanical methods may also be employed. The surface control methods depend on the situation. Well ignition, either accidental or deliberate, does not significantly affect the timeline for regaining well control using surface control methods since on-site equipment could be used to remove debris and permit access to the well.

Potential mechanical surface control methods include the following:

- Pumping mud or cement down the well to kill it.
- Replacing the failed equipment, if control was lost due to equipment failure.
- Plugging leaks in surface equipment, enabling circulation and ultimately the ability to regain well control.
- Removing some of the BOP stack and installing a master valve.

- Removal of existing surface BOP and perhaps wellhead equipment and replacement with a well capping stack. (This method would require diversion of existing flow to allow equipment installation.)

The critical path prior to choosing a specific method for regaining surface control, whether the well is ignited or not, is as follows:

1. Mobilize emergency response personnel and equipment,
2. Conduct a site assessment,
3. Develop safe access and work plans, and
4. Divert uncontrolled fluids for collection and handling to create a safe working environment and to minimize pollution.

The activities would be expected to take approximately one to two days. After these preparations, actual control methods could be implemented. The estimated duration to perform a full capping operation would be 15 days.

ExxonMobil will maintain contracts with well control firms to assist in the intervention and resolution of well control emergencies. Such services include, but are not limited to, firefighting equipment and services, specialty blowout control equipment and services, directional drilling services, high-pressure pumping services, and specialty fluids, chemicals and additives. Providers of such services include, but are not limited to, Cudd Well Control, Wild Well Control, Safety Boss, Halliburton Energy Services, Anadrill Schlumberger, Baker Hughes INTEQ, Dowell Schlumberger, Baroid, and MI Drilling Fluids. The approved contractor will be notified immediately in the event of any well control situation that has the potential to escalate.

ExxonMobil and partners maintain and have available on the North Slope the major equipment items to initiate well capping or other surface control options. Specialized equipment for surface intervention efforts during the drilling development phase at Point Thomson is listed in Table 1-7. Equipment not located on the North Slope can be mobilized in 24 hours. Heavy lift helicopters can be mobilized from Oregon, the Pacific Northwest, or Canada and arrive at Point Thomson within three days.

Relief Well Timing

While relief well drilling is not the primary method of source control at Point Thomson, provisions for relief well drilling, including estimates of time required for controlling a blowout with a relief well, are provided.

Relief well planning would start immediately in the event of a blowout, even though relief well drilling is not ExxonMobil's primary method of source control. While detailed planning of a relief well will necessarily depend on actual well conditions when a blowout occurs, certain general site-specific plans can be made in advance. The purpose of this section is to provide the basic plan, which will:

1. Identify a surface location for each potential relief well so that the site preparation can be expedited and drilling can begin at the earliest possible time.
2. Outline the basic logistics of rig mobilization and estimate the required timing for site preparation, rig mob/demob, drilling and well-kill operations.
3. Establish the hydraulic requirements to kill a Point Thomson blowout through a relief well.

**TABLE 1-7
SURFACE INTERVENTION EQUIPMENT LIST**

COMPONENT	SURFACE INTERVENTION USAGE	LOCATION	AVAILABILITY
6,000 gallons per minute (gpm) Fire Pumps	Fire and heat suppression.	North Slope	<18 hours
Athey Wagons	Tractorized booms for manipulation of tools in and around blowout well.	North Slope	<18 hours
D8 Bulldozer	Power for Athey wagons and backup for heavy equipment, rig moving. Can also be used for constructing berms to aid in spill containment.	PTU	<8 hours
Backhoe	Drainage ditch, berm construction.	PTU	<8 hours
85-100-ton Crane	Heavy equipment lifting capability. If well blowout is ignited, may be needed to facilitate rig move.	PTU	<8 hours
50-75-ton Crane	Smaller, mobile units for spotting support equipment.	PTU	<8 hours
500-ton Drilling Block	Block-and-tackle system for moving or dragging heavy equipment.	North Slope	<18 hours
Drilling Line	Component of block-and-tackle system if rig moving system is inoperable.	PTU	<8 hours
20-inch and 30-inch Casing	Used to construct Venturi tubes to divert blowing well bore fluids (ignited and unignited).	PTU	<8 hours
Miscellaneous Equipment	High-pressure chocks, flexible hoses, valves, containment boom, absorbent, and hand tools.	North Slope	<18 hours
Kill Pumps	Backup to rig pumps.	North Slope	<24 hours
Junk Shot Manifold	Manifold system constructed to pump small leak-sealing materials into well.	North Slope	<18 hours
Hot Tap Tool	Manifold used to gain safe access to pressurized tubulars at surface.	North Slope	<18 hours
Crimping Tool	Sized device used to pinch tubulars closed to seal off internal flow.	Houston, Texas	<24 hours
Abrasive Cutter	High-pressure cutting tool used to sever leaking BOPs, and rig structures.	Duncan, or Houston, Texas	<24 hours
Capping Stack	Various high-pressure BOP stacks (to replace leaking, damaged, or severed primary BOPs).	Houston, Texas	<24 hours

If Point Thomson Unit is Developed with Two Drilling Rigs

If two rigs are used to drill the Point Thomson development wells, the rig that is not drilling the blowing well would be used to drill a relief well as soon as operations with that rig are safely suspended. The two rigs are not assumed to be of equal size and capacity; the larger rig would principally drill the longer throw wells (on the West and Central pads), while the smaller rig would be used to drill shorter reach wells on all three pads. If a blowout were to occur on a long throw well being drilled by the larger rig, the question arises whether the smaller rig could drill the required relief well, given its reduced capacity to drill extended reach wells. To assure a positive answer to this question, the surface location for the relief well must be chosen such that it is technically feasible to drill the required relief well with the available rig.

In order to drill a relief well with the smaller rig to the longer-reach bottom-hole locations, the relief well surface locations could be located on an existing offshore island, i.e., Challenge Island or Mary Sachs Island. The overall drilling schedule has been planned so that, if

needed, the smaller rig can be mobilized to the island without delay over ice roads during the season when transport of heavy loads over sea ice is feasible (January through April).

An additional requirement in choosing the relief well sites is that protection from explosion hazard and/or condensate from the blowout, or the combustion by-products if the well is burning, do not adversely impact the proposed location. By choosing sites that are either north-northwest or south-southeast of the pads in most instances, any undesirable effects due to prevailing winds from the east-northeast or west-southwest would be minimized. In any event, the surface locations range from about 1 to 4 miles from the blowout well surface locations, distances substantially larger than the 1,000 to 1,500 feet common in most relief well operations. Liquid and/or soot fall-out at the relief well site is therefore not expected to pose any safety or operational risk whatsoever at the relief well work site.

The sites of prior exploration/appraisal wells may be used wherever possible to minimize site preparation and drilling times, as well as disturbances to the tundra.

If Point Thomson is Developed with One Drilling Rig

If a single rig is used to drill all of the Point Thomson development wells, it would likely be severely damaged either by the blowout or from voluntary well ignition, and it could not be used for relief well drilling. In this case, a rig would be mobilized from elsewhere on the North Slope to begin drilling a relief well while surface intervention methods were being pursued.

An agreement to provide a relief well drilling rig will be in place with other operators and one or more rig contractors on the North Slope prior to the spud of the first development well.

Relief Well Logistics/Timing

Several factors contribute to the logistics and timing of relief well drilling operations, including:

1. Immediate availability of a drilling rig at PTU to drill the relief well in the two-rig development case or the potentially long mobilization time to bring in a rig from elsewhere in the one-rig case.
2. Relatively long drilling times possible due to the extended-reach and associated measured depths of many of the required relief wells.
3. Permanent roads in the development area that greatly facilitate moving the rig to most preferred relief well locations.
4. Use of existing pads from many prior wells as drill sites for the relief wells.
5. Permanent stationing of heavy equipment at PTU for site and road-building work.
6. On-site warehousing of both tangibles and consumables that would be used in the relief well.

The following are estimates of the time required for controlling a blowout using a relief well:

1) Construction of ice road (island sites)	up to 10 days
2) Modification of existing pad	1 to 3 days
3) Mobilization of equipment, rig up, and preparation to spud	5 to 10 days
4) Drilling relief well	65 to 115 days
5) <u>Killing blowout well</u>	<u>10 days</u>
TOTAL	81 to 148 days

These estimates exclude the time necessary to mobilize a rig from outside PTU.

The time needed for drilling a relief well varies, primarily due to the measured depth of the well, but also based on a number of unpredictable conditions, including weather, cause of blowout, and the choice of surface location. Relief well measured depths range from approximately 2,000 feet to 19,000 feet.

It would take ten days or less to mobilize any additional ice road construction equipment that may be needed and build the ice road to an island relief well location. In this instance the relief well cellar, conductor, and sheetpile could be transported to the location by Rolligon prior to completion of ice roads and be prepared for drilling.

Time Estimate to Mobilize a North Slope Rig to Point Thomson

If a rig must be mobilized from elsewhere on the North Slope to drill a relief well as in a one-rig scenario, the mobilization time would be additive to the preceding time estimates. Depending on the time of year that the blowout occurred and hence the relative difficulty of access to PTU, a substantial amount of time could be required to bring in the relief well rig.

A relief well could be initiated between January 1 and May by mobilizing a rig over ice roads. The well could be spudded within six weeks of the start of relief well pad construction.

It would take ten days or less to mobilize ice road construction equipment and build ice roads to a relief well location. This construction equipment is readily available in both Deadhorse and PTU. The relief well cellar, conductor, and sheetpile could be transported to the relief well locations by Rolligon prior to completion of ice roads and the site could be prepared for drilling. Gravel would be hauled from the local pit over permanent roads to the drill site to repair an existing well pad left from exploration/appraisal drilling operations. Upon completion of ice roads, a new pad would be constructed for the relief well. The rig would then be mobilized to the location.

If a well control problem occurs after May in a one-rig scenario and the existing rig cannot be moved off for use on the relief well, a summer mobilization of a rig by barge would be required. This scenario and timing are depicted on the lower portion of Figure 1-5C and Figure 1-5E. Open water occurs most years in the Point Thomson area by July 15; however, mobilization would occur as soon as broken-ice conditions allowed safe access by barge to the PTU dock. Barges that could transport a rig to PTU relief well locations in ten days are available at Deadhorse year-round, so a rig could be mobilized to the barges and ready to transport as soon as broken-ice conditions allowed safe access by barge. Assuming that a blowout occurs on July 15, a relief well could be spudded by late August.

Relief Well Design and Hydraulic Requirements for Well Kill

In view of the very high productivity of the Point Thomson wells, each of the relief wells will target the Thomson sand, since the entire wellbore length of the blowing well can then be used to accumulate the hydrostatic and friction pressure that are essential to accomplishing the well kill. Intermediate-depth kill attempts are not feasible for two reasons, even though the drilling time would be much shorter for such a plan: First, because of the relative well trajectories, a well that was targeted to an intermediate depth could not easily be redirected to a deeper intersection depth if the blowout could not be killed at the shallower depth. Starting a new relief well would be required, and the time spent drilling to the intermediate depth would essentially be wasted. Second, given the substantial kill requirements at the deeper intersect (to be discussed later in this section), the probability of successfully killing the well hydraulically at an intermediate depth is very unlikely.

Efficiency of pumping operations for the kill will be highest if direct inter-well communication can be established so that no fluid is lost to the formation. Achieving a direct intersect is quite feasible, but directional control and use of magnetic ranging devices will be more difficult. Not only will the relatively high angles (up to 66 degrees) of some of the well holes likely preclude the use of some gyro tools, but the performance of both directional Measurement While Drilling (MWD) and magnetic ranging tools at high latitudes will also be degraded, especially if sunspots and/or other magnetic disturbances are occurring. Tool vendors indicate that relief well operations could be slowed or halted for as much as ten days if magnetic storms are persistent; however, the vendors are confident that any needed relief well can successfully meet desired directional objectives.

Tubulars in the relief well must be sized so they are capable of delivering necessary kill fluid volumes to the blowout. As a rough approximation, the minimum cross-sectional area of the relief well available for injection should be about the same size as the corresponding area of the blowing well. In the most likely blowout scenario, flow occurs up a 9 7/8-inch casing by 5-inch drill pipe annulus. The same wellbore geometry was assumed for the initial calculation of relief well hydraulics. Because the reach of many of the potential relief wells is long, it is likely that an 11 7/8-inch intermediate liner will be required to ensure that 9 7/8-inch casing can be set prior to penetrating the Thomson reservoir.

If returns are lost in the relief well upon penetrating the blowout wellbore and/or the partially drawn-down Thomson sand, well killing operations would begin immediately. Setting 9 7/8-inch casing immediately above the Thomson sand will prevent mechanical failure of the overlying shales if relief wellbore pressures drop briefly upon initial wellbore intersection while the kill pumps are being brought on-line.

Blowout kill requirements were determined using the same proprietary wellbore simulator used to model well unloading and stabilized flow performance of the blowing well. In the case of the well kill simulations, the initial condition is a well blowing condensate and gas. Mud is then introduced into the lower section of the reservoir in the blowing well, usually at constant density and constant pump rate, and the well begins to load up with liquid mud as the simulation steps forward in time. If density and rate are held constant, there are two possible outcomes: either the well will die (in which case the pumping time and minimum required volume to stop flow from the reservoir are determined), or the well does not die (in which case the well simply stabilizes at a reduced flow rate due to the added pressure of the mud in the wellbore). If the well dies, continued simulation models the displacement of the

FIGURE 1-5C
RELIEF WELL OPTIONS DURING THE YEAR

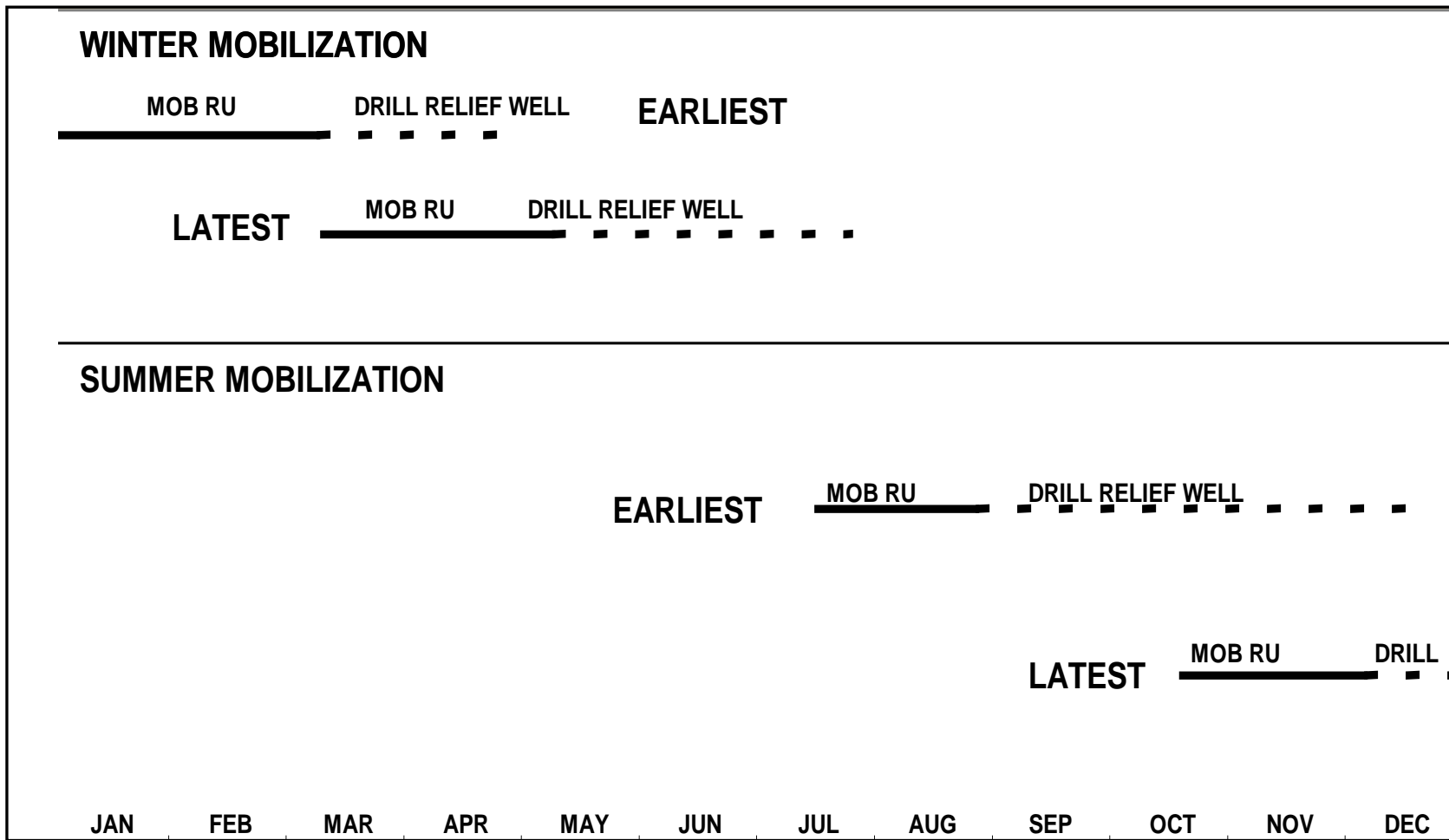

FIGURE 1-5D
WINTER MOBILIZATION FOR RELIEF WELL

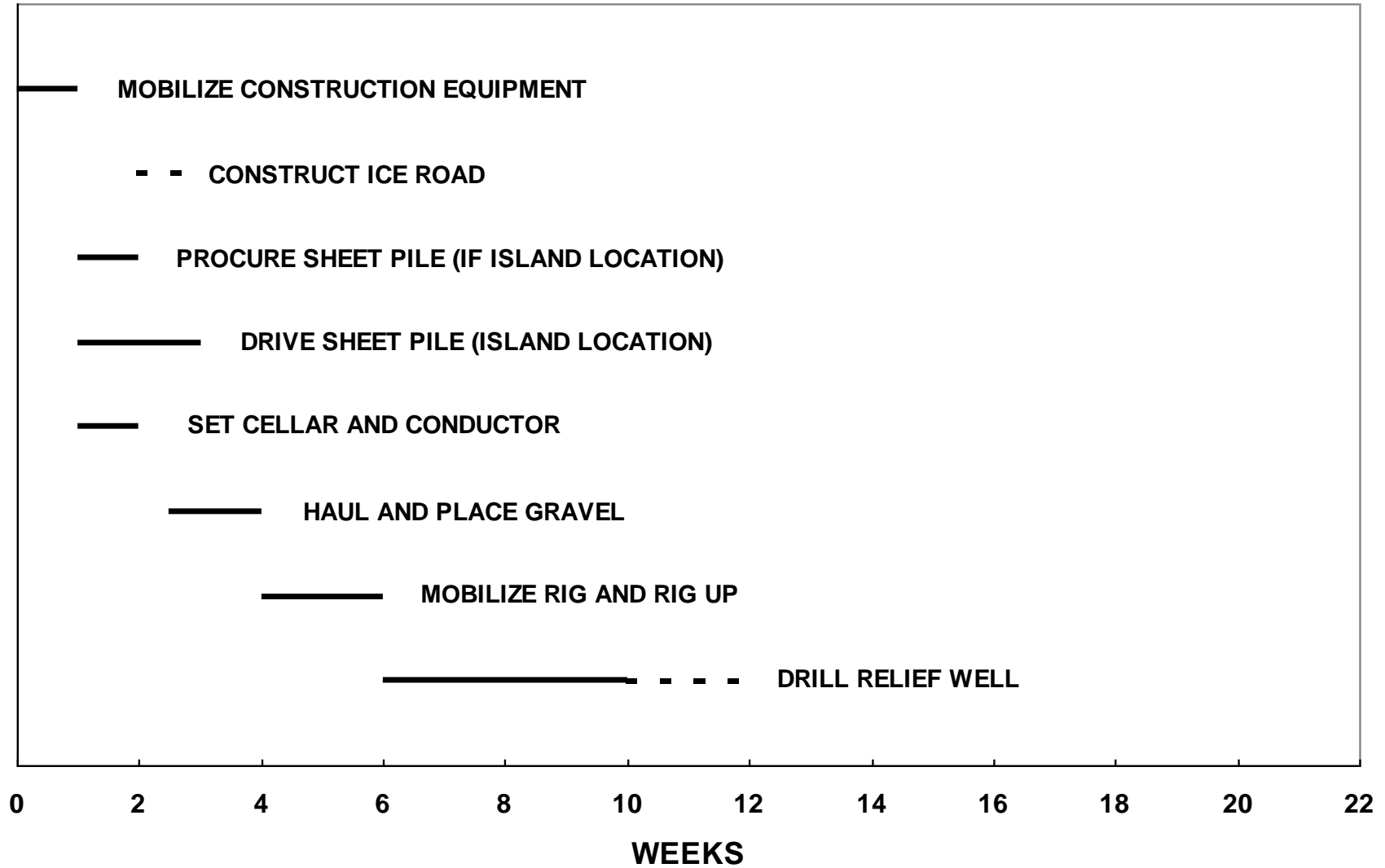
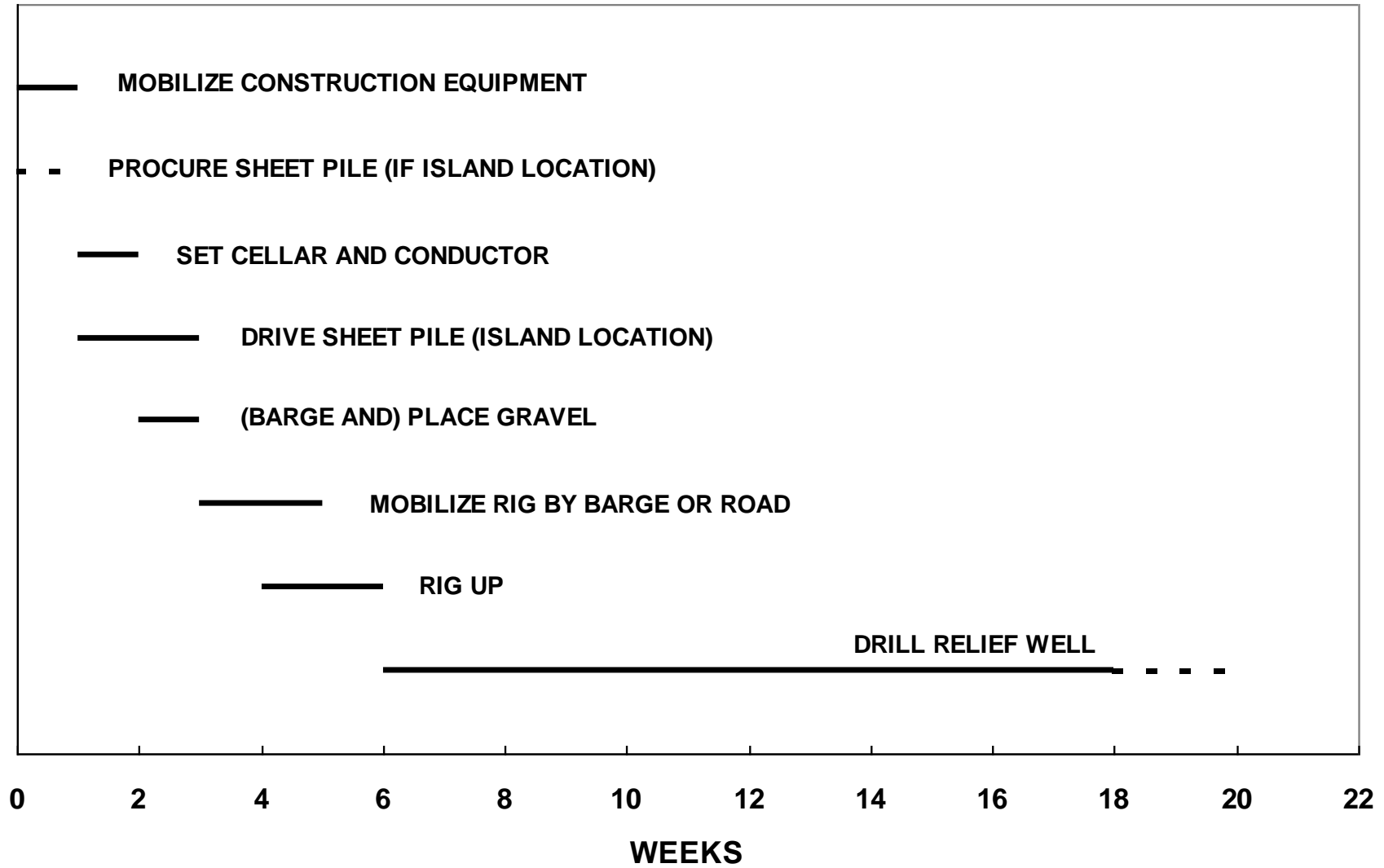

FIGURE 1-5E
SUMMER MOBILIZATION FOR RELIEF WELL



mud/gas/condensate mixture from the wellbore. If the well does not die, the simulation is repeated with heavier mud and/or higher pump rate until the well does die. If the well still cannot be killed (with an acceptable surface injection pressure), larger-bore tubulars in the relief well are usually required. In the event of a real blowout, the simulations would be refined to include reductions in pump rate, and perhaps density, to develop a pumping schedule that ultimately leads to a static well kill with the pumps off and with no losses at the casing shoe.

Summary

While plans call for surface intervention techniques to be employed in the event of a blowout, ExxonMobil is nevertheless fully prepared to drill a relief well at Point Thomson. The time required to bring a blowing well under control using a relief well will likely be significant, due principally to the depths of the blowing/relief wells and to the potential need to mobilize a relief well drilling rig from Deadhorse.

Permits

In the event of a well blowout, federal, state, and North Slope Borough (NSB) permits might be required to support the response effort. The permits would authorize the construction of gravel and offshore or onshore support facilities (e.g., ice and gravel staging pads, temporary storage areas, and temporary water use). As part of overall North Slope oil spill preparedness, ACS holds a series of permits authorizing a variety of cleanup-related activities, including bird and mammal hazing, and mammal stabilization.

ACS Tactics
A-3 and W-1

1.6.4 Discharge Tracking [18 AAC 75.425(e)(1)(F)(iv)]

Discharge tracking is discussed in Section 1.6.14 and in the ACS *Technical Manual*.

ACS
Tactics T-1
through T-7

1.6.5 Protection of Sensitive Areas [18 AAC 75.425(e)(1)(F)(v)]

Environmentally sensitive areas and areas of public concern include cultural resource sites, public use areas, Native allotments, and bird nesting areas. Initial strategies for protection and cleanup of these areas will be determined based on the agency priorities and data in the ACS *Technical Manual, Volume 2, Map Atlas*. Each open water, nearshore, and offshore marine area from Mikkelsen Bay to Kaktovik is subject to some probability of oiling from potential unrecovered spills. Stream sections down-slope from the condensate export pipeline are also subject to oil spills.

ACS
*Technical
Manual,
Volume 2,*

Shoreline sites marked on the maps for priority protection are based on the following criteria:

- Relative value as wildlife habitat or as cultural resource, subject to confirmation by resource agencies;
- Distance from a potential oil spill, as a qualitative index of probability of oiling; and
- Practicality of protection measures, to be determined by spill responders at the time of the response.

As a spill response progresses, priorities may change based on seasonal variations and assessments conducted at the time of the spill. For incident-specific applicability, see Section 1.6.14.

ACS Tactic
W-6

1.6.6 Containment and Control Strategies [18 AAC 75.425(e)(1)(F)(vi)]

Containment and control strategies are discussed in Section 1.6.14 and in the ACS *Technical Manual*.

ACS
Tactics C-1
through C-
16

1.6.7 Recovery Strategies [18 AAC 75.425(e)(1)(F)(vii)]

Recovery strategies are discussed in Section 1.6.14 and in the ACS *Technical Manual*.

ACS
Tactics R-1
through
R-31

1.6.8 Lightering, Transfer, and Storage of Oil from Tanks [18 AAC 75.425(e)(1)(F)(viii)]

Incident-specific applicability of lightering, transfer, and storage is discussed in Section 1.6.14. ACS *Technical Manual* Tactics R-22 through R-25, R-27, and R-28 describe the detailed operational and resource requirements associated with offloading operations.

ACS Tactics
R-22
through
R-25, R-27,
and R-28

1.6.9 Transfer and Storage Strategies [18 AAC 75.425(e)(1)(F)(ix)]

Transfer and storage strategies are discussed in Section 1.6.14 and in the ACS *Technical Manual*.

ACS
Tactics R-6,
R-7, R-10,
R-11, R-15
through
R-20, R-22
through R-
24, R-28,
R-30, and
R-31

1.6.10 Temporary Storage and Disposal [18 AAC 75.425(e)(1)(F)(x)]

The method of disposal for oil and contaminated materials from spill recovery operations, or for oily waste from normal operations, must be approved by state and federal agencies. At the time of the spill, the Operations Section Chief, in consultation with the SHE Lead, would determine a reuse, recycle, or disposal method best suited to the state of the oil, the degree of contamination of recovered debris, and the logistics involved. Application for agency approvals would be completed before the method of disposal is used. An initial determination would be made regarding the classification of the waste as exempt, hazardous, or non-hazardous. This classification may be made on a case-by-case basis. The SHE Lead will provide assistance in determining the classification, should the status of the waste material be in question. In general, the following guidelines apply:

ACS
Tactics D-1
through D-5

- Spilled material will be re-used or recycled when possible.
- Spills from the DOT-regulated export oil pipeline are non-exempt and must be tested to determine whether the material to be disposed of is hazardous.
- Spills from production well lines and multi-phase flowlines are exempt and therefore non-hazardous.
- Spilled material that comes out of a well, either during drilling or workover operations, is exempt and therefore non-hazardous. Material spilled during drilling or workover operations that did not come out of a well is non-exempt and must be tested to determine whether the material to be disposed of is hazardous.
- Spills that occur from filling a tank (e.g., vehicle, storage, etc.) are non-exempt, even though they may occur on a well pad. They must be tested to determine whether the material to be disposed of is hazardous.

The preferred method for handling recovered liquid oil is disposal in the Point Thomson disposal well. The preferred option for recovered diesel is reuse (e.g., as freeze protection during drilling operations). In this case, the diesel will be stored on-site. If the diesel is not suitable for freeze protection, it will be tested to determine if it is hazardous. If hazardous, it will be stored in drums on-site until it can be shipped to an approved hazardous waste disposal facility. If non-hazardous, it may be injected in the Point Thomson disposal well.

Contaminated gravel will be temporarily stored on-site with pre-approval from ADEC for the temporary storage of oily waste associated with response activities. The materials may be transported later by truck over ice road or by vessel to Deadhorse for treatment. Alternatively, contaminated gravel may be remediated or disposed of at the PTU, e.g., by washing, incineration, bioremediation, or injection in the Class I disposal well.

ACS Tactic
D-4

Other solid waste may be incinerated on-site or stored for later transport to Prudhoe Bay for disposal. Point Thomson will have two incinerators, each with a capacity of 300 pounds per hour. One of the incinerators will operate while the other incinerator is cooled, cleaned, and loaded. Consequently, even with two incinerators, the cumulative waste incineration capacity will be 300 pounds per hour. The incinerators will be designed and operated in compliance with the Incinerator Emissions Standards, outlined in 18 AAC 50.050. A percentage of the waste handled by the incinerators can be oily waste. Non-combustible solid waste and the majority of oily waste will be stored for later transport to Prudhoe Bay for disposal.

Liquids recovered from a large oil spill are either liquid oil or oil mixed with water, snow, or ice. Oil in excess of immediate processing capacity will be stored in tanks. Sources of tankage include:

- Process waste collection vessel at Point Thomson,
- Spill response equipment at Point Thomson,
- ACS spill response equipment located in Deadhorse, and
- North Slope contractors and Mutual Aid partners.

Specific types and capacities of temporary storage are described in the *ACS Technical Manual*. Additional sources of temporary storage tanks include oil companies and numerous service companies in the North Slope area. These storage tanks include 500 bbl Tiger tanks and 200 to 300 bbl vacuum trucks. Mobile tankage is estimated at 20,000 bbl in the North Slope area.

ACS
Tactics D-1
through D-5

Storage of cleanup materials is described in the *ACS Technical Manual*.

1.6.11 Wildlife Protection [18 AAC 75.425(e)(1)(F)(xi)]

Wildlife protection strategies are discussed in the *ACS Technical Manual*.

ACS
Tactics W-1
through
W-6

1.6.12 Shoreline Cleanup [18 AAC 75.425(e)(1)(F)(xii)]

Shoreline cleanup strategies are discussed in *ACS Technical Manual*.

ACS
Tactics
SH-1
through
SH-12

1.6.13 Response Planning Standards [18 AAC 75.430]

Well Blowout [18 AAC 75.434]

Modeling Liquid Flow Rates

The response planning standard volume calculation involves a simulated condensate flow rate that is predicted with a computer model. The model assumes that the blowout fluids move up the annulus between a 5-inch-diameter drill string and an 8.5-inch hole and the inside diameter of 9 7/8-inch casing.

The blowout modeling computer program predicts the flow of hydrocarbons from the subsurface reservoir into and up the wellbore that routes them to the surface. Because blowouts do not occur instantaneously, but over timescales that vary from several minutes to several days, the computer models calculate the changes in pressures, flow rates, fluid densities and wellbore contents as these quantities change over time. The pressures and fluid characteristics vary with distance between the reservoir and the Earth's surface.

The simulation begins by specifying the initial conditions in the reservoir and in the wellbore. Fluids in the reservoir are typically assumed to be in an equilibrium state; in a sense they are pressurized and waiting to be let out of the reservoir. In normal drilling operations, the wellbore usually contains drilling "mud," a special high-density mixture of solids and fluids. One function of the mud is to exert a downward force that keeps the hydrocarbons confined to the reservoir. In more technical terms, the density of the mud is specifically chosen so that the hydrostatic pressure it exerts is greater than the reservoir pressure, thereby preventing the well from flowing. But to initiate flow in the simulated blowouts, the density of the mud is set at an artificially low and insufficient value in order to simulate a pressure imbalance that becomes the driving force for further flow.

Well-established mathematical equations in the blowout simulator computer program describe how fluids in the reservoir move when they are subjected to differences in pressure. The flow rates of the hydrocarbons through the reservoir depend on the properties of both the rock and the fluids. Important formation parameters include the permeability, which is a measure of the ease with which fluids move through the tortuous and interconnected pore spaces of the reservoir rock and the reservoir thickness. The relatively high permeability (measured in units of millidarcies) and thickness of the Thomson Sand formation produce high flow rates in both controlled and uncontrolled flow situations; indeed, the commerciality of the project is due in part to these very properties of the prolific Thomson Sand. Similarly, the low viscosities of the gas and condensate and the high initial reservoir pressure also contribute to high well productivity.

In addition to these fundamental elements of flow in the reservoir, the mathematical model also considers factors like turbulent flow and the fact that the wellbore may be directionally drilled through the reservoir or may only partially penetrate a fraction of the entire reservoir thickness. As simulated time advances and more reservoir fluids are produced, pressures near and at base of the wellbore decline. The model calculates the time-dependent bottom-hole pressure, an important quantity because it is the motive force pushing the fluids up the wellbore to the surface.

The flow of liquids (both mud and condensate) and gases in the wellbore is also an integral part of the blowout simulation. Equations that describe the movement of these fluids are

solved repeatedly as the simulation steps forward in time, thereby continuously updating where the fluids are, how fast they are moving, and how pressures throughout the wellbore vary with time. As previously noted, the wellbore contains only mud initially; moreover, the pressure at the top of the well is due only to the atmosphere, and the bottom-hole pressure is due principally to the weight of the column of drilling mud. The flow of hydrocarbons from the reservoir eventually displaces all of the mud from the wellbore, and the fluid exiting the wellbore changes from being exclusively mud to a mixture of gas and condensate. The simulated well is blowing out at that point. The gas and condensate flow rates decline gradually over time as the reservoir is depleted, and pressures in the formation near the wellbore decrease.

The mathematical description of wellbore hydraulics is quite complex. The simulation must account for physically diverse phenomena: gravity that counters the upward direction reservoir pressure forces the fluids to flow, the interactions between the liquid and vapor phases, and pressure losses associated with friction and the acceleration of fluids to near-supersonic velocities as they flow toward the Earth's surface. In addition, the conduit for flow is geometrically complicated. Typically, an inclined annulus consists of either the borehole wall or steel casing in the well on the outside and the varying diameters of the drill string on the inside. Finally, the rates and pressure of the fluids entering the wellbore must match exactly the rates and pressures of the fluids exiting the formation, while the rates and pressure at the top of the wellbore must match the requirements for flow from an orifice to the atmosphere.

With these special-purpose blowout simulation methods, ExxonMobil determined the expected flow rates that would be encountered in the unlikely event of a Point Thomson blowout. The simulations used site-specific reservoir and fluid data and the specifications of the wellbores planned for development of several blowout scenarios at Point Thomson.

Voluntary ignition of a blowout is ExxonMobil's preferred alternative for ensuring the safety of personnel and protection of the environment from large quantities of liquid condensate at Point Thomson. The air pollutant of most concern from burning oil or condensate is particulate matter, in this case, non-combusted condensate as soot. ExxonMobil used the SCREEN3 model to determine if particulate matter emissions from a burning blowout at Point Thomson have the potential to create exceedences of the national standards (EPA, 1995a). It is anticipated that any condensate blowout at Point Thomson will behave much like an industrial flare, which is designed for efficient combustion. Combustion of a Point Thomson blowout will be very efficient because the high velocity of the high-heating-value reservoir fluids exiting the well will lead to significant air entrainment¹. The estimated combustion efficiencies are expected to be 99 percent for the gaseous components and approximately 90 percent for the liquids. Soot emissions for air quality modeling were based on all 10 percent unburned liquid forming soot and on light smoking of the gaseous fraction (approximately 310 grams of soot per million British Thermal Units [BTUs] fired, EPA's manual for emissions estimating BTU, 1995b). That is, ExxonMobil used a conservative assumption that all unburned components of the smoke plume were particulates. Based on results using EPA's SCREEN3 model, the maximum ground-level concentration of PM₁₀ (particulate matter 10 microns in diameter) is predicted to be 65.6 micrograms per cubic meter ($\mu\text{g}/\text{m}^3$), well below the 24-hour average National Ambient Air Quality Standard of 150 $\mu\text{g}/\text{m}^3$.

ExxonMobil also studied the gas/condensate plume from an unignited blowout at Point Thomson using a computer model, known as SCIPUFF (Titan, 2003), to determine the

¹ Communication with Mr. Robert Schwartz of John Zink Company.

amount and distribution of the liquid condensate that would fall to land and water. SCIPUFF is an EPA-approved model. ExxonMobil used the following assumptions for the model:

- The predictions of droplet-size distribution used are conservative for Point Thomson well blowout cases because additional droplet break-up mechanisms of flashing and supersonic mechanical break-up were ignored. Supersonic break-up (as flow can exceed the speed of sound at discharge) may produce even smaller droplet sizes due to mechanical break-up, while flashing of liquids on discharge produce smaller drops than from only mechanical break-up.
- The predictions of deposition may be conservative for Point Thomson because the evaporative properties of a less volatile component (i.e., dodecane) were used that may over-estimate deposition for more volatile compounds (e.g., octane).
- The drill pipe is still in hole (hole diameter is 8.5 inches, and drill pipe outside diameter is 5 inches).
- Flow rates are 465 million standard cubic feet per day (mmscf/d) of gas and 27,000 bbl of condensate per day for 15 days.
- The condensate characteristics are presented in Table 1-8.

**TABLE 1-8
SUMMARY OF CONDENSATE CHARACTERIZATIONS
FOR RELEASE TO THE ATMOSPHERE
(MOLE PERCENT)**

COMPONENT	PRODUCED GAS STREAM (%)	WELLHEAD LIQUID FOR BLOWOUT (290 PSIA @ 210°F (%))	LIQUID FLASHED TO 40°F AND 14.65 PSIA (%)	
N ₂	0.6	0.0	0.0	Non-Persistent Components
CO ₂	4.4	0.5	0.1	
Methane	83.8	5.3	0.4	
Ethane	4.2	0.9	0.3	
Propane	1.7	0.8	0.6	
I-Butane	0.4	0.3	0.3	
N-Butane	0.6	0.7	0.7	
I-Pentane	0.2	0.5	0.5	
N-Pentane	0.3	0.6	0.6	
C ₆	0.5	3.3	3.6	
C ₇	0.4	6.0	6.4	
C ₈	0.4	9.0	9.6	
C ₉	0.3	7.8	8.3	
C ₁₂	1.1	33.7	35.9	
C ₁₇	0.7	20.4	21.8	
C ₂₇	0.3	8.5	9.1	More Persistent Components
C ₄₂	0.0	1.3	1.3	
C ₆₅	0.0	0.3	0.3	
C ₈₆₊	0.0	0.1	0.1	
Total	~100	~100	~100	

psia = pounds per square inch absolute
 °F = degrees Fahrenheit
 N₂ = Nitrogen
 CO₂ = Carbon dioxide
 C_# = Various organic compounds

Simulated Rates

Liquid flow rate (barrels per day [bpd]) ¹	27,000
Combustion efficiency (%)	90
Uncombusted condensate as soot (%)	99
Evaporation from aerial droplets (%)	25
Evaporation of condensate from water and land surface (%)	40
Duration of blowout period (days)	15

Prevention Credits

Alcohol and drug testing credit	5%
Operations training or Federal certification credit	5%
Real time bottom-hole pressure measurements credit	5%
Computer preventative maintenance system credit	5%
Formal safety analysis credit	5%
Emergency shutdown SCSSV valves	5%
Operations Integrity Management System (OIMS)	10%
Assurance of well tubular integrity	5%
On-site mud plant	5%
Overbalanced drilling confirmation technique	5%
Five-preventer BOP stack	10%

See Section 2.6.1 for a description of prevention credits claimed for the Point Thomson well blowout RPS volume.

Response Planning Standard (RPS) Volume Calculation

Initial RPS Volume, Day 1, Hours 0 to 2	=	27,000 bpd x 2 hr to ignite / 24 hr per day x (1 - 0.25) x (1 - 0.40) after aerial and surface evaporation = 1013 bbl
Adjusted RPS Volume, Day 1, Hours 0 to 2 (prior to well ignition)	=	1013 bbl x (0.95 credit x 0.95 credit x 0.95 credit x 0.95 credit x 0.95 credit x 0.95 credit x 0.90 credit x 0.95 credit x 0.95 credit x 0.95 credit x 0.90 credit) = 517 bbl
Initial RPS Volume, Day 1, Hours 2 to 24	=	(27,000 bpd x 22 hr / 24 hr x 0.10 unburned x 0.01 liquid deposition) = 24.75 bbl
Adjusted RPS Volume, Day 1, Hours 2 to 24	=	24.75 bbl x (0.95 credit x 0.95 credit x 0.95 credit x 0.95 credit x 0.95 credit x 0.95 credit x 0.90 credit x 0.95 credit x 0.95 credit x 0.95 credit x 0.90 credit) = 13 bbl
Total Adjusted RPS Volume, Day 1	=	517 bbl + 13 bbl = 530 bbl
Initial RPS, Days 2 through 15	=	14 days x (27,000 barrels of oil per day (bopd) x 0.10 unburned x 0.01 liquid deposition) = 378 bbl

¹ ExxonMobil Modeled Case 1, annulus route, drill pipe in hole.

$$\begin{aligned}
 \text{Adjusted RPS Volume, Days 2 through 15} &= 378 \text{ bbl} \times (0.95 \text{ credit} \times 0.95 \text{ credit} \times 0.95 \text{ credit} \\
 &\quad \times 0.95 \text{ credit} \times 0.95 \text{ credit} \times 0.95 \text{ credit} \times 0.90 \\
 &\quad \text{credit} \times 0.95 \text{ credit} \times 0.95 \text{ credit} \times 0.95 \text{ credit} \times \\
 &\quad 0.90 \text{ credit}) = 193 \text{ bbl} \\
 \\
 \text{Day 1, Hours 2 to 24 Volume plus Days 2 through 15 Volume (after well ignition)} &= 13 + 193 = 206 \text{ bbl} \\
 \\
 \text{Total Adjusted RPS Volume (Days 1 through 15)} &= 517 + 206 = 723 \text{ bbl}
 \end{aligned}$$

Condensate Export Oil Pipeline [18 AAC 75.436]

The response planning standard (RPS) volume assumes an instantaneous guillotine rupture at milepost 14.7 of the pipeline.

The location was selected based on the consideration that it is one of the most remote points of the pipeline crossing a water body. Consequently, it would be among the most challenging locations for spill responders.

The RPS volume value is calculated using the following equation from 18 AAC 75.436:

$$\text{RPS Volume} = (L - H) \times C + \text{FR} \times (\text{TD} + \text{TSD})$$

Where:

- L = pipeline length between valves
- H = pipeline hydraulic characteristics due to terrain
- C = pipeline capacity in bbl per linear measure
- FR = pipeline oil flow rate in bbl per time period
- TD = estimated time to detect a spill event
- TSD = time to shut down the pipeline pump or system

- L = 112,992 feet (21.4 miles x 5,280 feet per mile)
- H = 107,184 feet (20.3 miles x 5,280 feet per mile)
- C = 0.145 bbl/linear foot (LF) = $[(12.75\text{-inch outside diameter} - 2 \times 0.28\text{-inch wall thickness}) / 2]^2 \times 3.14 / 144 \text{ square inches per square foot}] / 5.6 \text{ cubic feet/bbl}$
- FR = 69.44 bbl/minute (100,000 bbl/day / 1,440 minutes/day)
- TD = 3 minutes
- TSD = 5 minutes

Therefore:

$$\begin{aligned}
 \text{Initial RPS Volume} &= [(112,992 \text{ feet} - 107,184 \text{ feet}) \times (0.145 \text{ bbl/LF})] + (69 \text{ bbl/minute} \\
 &\quad \times 8 \text{ minutes}) \\
 &= 1,394 \text{ bbl}
 \end{aligned}$$

$$\begin{aligned} \text{Adjusted RPS Volume} &= 1,394 \text{ bbl} \times 0.95 \text{ for 5\% drug and alcohol testing credit} \times 0.95 \text{ for} \\ &\quad 5\% \text{ on-line leak detection system} \times 0.85 \text{ for 15\% corrosion} \\ &\quad \text{control using smart pigs} \times 0.40 \text{ for 60\% loss from evaporation} \\ &= 428 \text{ bbl} \end{aligned}$$

See Section 2.6.3 for a description of prevention credits claimed for the Point Thomson condensate export pipeline RPS volume.

Fuel Storage Tank Rupture [18 AAC 75.432]

The adjusted RPS volume for the fuel storage tank at the CPF is calculated below. None of this simulated volume would spill to open water. See Section 2.6.2 for a description of prevention credits claimed for the Point Thomson fuel storage tank rupture RPS volume.

Initial RPS Volume (capacity of the tank)	12,500 bbl
60% adjustment for secondary containment	<u>-7,500 bbl</u>
Subtotal	5,000 bbl
5% adjustment for alcohol and drug testing	<u>-250 bbl</u>
Subtotal	4,750 bbl
5% adjustment for operations training and licensing	<u>-237.5 bbl</u>
Subtotal	4,512 bbl
5% adjustment for on-line leak detection for tank and piping	<u>-226 bbl</u>
Subtotal	4,287 bbl
15% adjustment for fail-safe valve piping systems	<u>-643 bbl</u>
Subtotal	3,644 bbl
25% adjustment for double bottoms with leak detection	<u>-911 bbl</u>
Subtotal	2,733 bbl
TOTAL Adjusted RPS Volume	2,733 bbl

1.6.14 Response Scenarios [18 AAC 75.425(e)(1)(F)]

The scenarios that follow were developed in accordance with 18 AAC 75.425(e)(1)(F) and 18 AAC 75.445(d). They describe equipment, personnel, and strategies that could be used to respond to an oil spill. The scenarios are for illustration purposes only and are not performance standards or guarantees of performance. The scenarios assume conditions of the spills and responses only for the purposes of describing general procedures, strategies, tactics, and selected operational capacities.

Some details in the scenarios are examples. Although some equipment is named, it may be replaced by functionally similar equipment. The response timelines are for illustration only. They do not limit the discretion of the persons in charge of the spill response to select any sequence or take whatever time they deem necessary for an effective response without jeopardizing personnel safety.

In situ burning could be used in a spill response to reduce the quantity of oil, regardless of whether a scenario illustrates *in situ* burning as a primary response option. In this plan, *in situ* burning means burning oil where it has spilled, as an oil removal technique. *In situ* burning excludes ignition of hydrocarbons in an aerial blowout plume or burning of oily waste material.

Actual responses to an oil spill event depend on personnel safety considerations, weather and other environmental conditions, agency permits, response priorities, and other factors. In any incident, considerations to ensure the safety of personnel will be given highest priority. The scenarios assume the agency on-scene coordinators and other agency officials will immediately grant any required permits.

The scenarios are generally based on information contained in the ACS *Technical Manual*, except where the information does not apply to condensate, a non-persistent material, and except that meteorological data from the Point Thomson area are used for blowout plume wind.

ACS <i>Technical Manual, Volume 1</i>
--

The scenarios assume reduced operational hours per shift and skimming rates less than nameplate capacity to account for realistic maximum operating limitations and other down-time factors.

Some scenarios simulate use of heavy equipment, e.g., trucks and front-end loaders. Staff in the equipment operator category typically operate their equipment on a regular schedule on the North Slope unrelated to spill responses and are not members of the NSSRT.

SCENARIO CONTENTS

Scenario 1	Point Thomson Condensate Export Pipeline Spill To Open Water	1-51
Scenario 2	Point Thomson Condensate Export Pipeline Spill During Break-Up	1-63
Scenario 3	Point Thomson Diesel Tank Rupture During Summer	1-73
Scenario 4	Point Thomson Diesel Tank Rupture During Freeze-Up.....	1-83
Scenario 5	Point Thomson Well Blowout During Summer	1-93
Scenario 6	Point Thomson Well Blowout During Winter.....	1-105

THIS PAGE INTENTIONALLY LEFT BLANK

SCENARIO 1

POINT THOMSON CONDENSATE EXPORT PIPELINE SPILL TO OPEN WATER

THIS PAGE INTENTIONALLY LEFT BLANK

**TABLE 1-9
CONDENSATE EXPORT PIPELINE SPILL TO OPEN WATER
SCENARIO CONDITIONS**

PARAMETER	PARAMETER CONDITIONS
Spill Location	Condensate export oil pipeline crossing of unnamed creek near pipeline milepost 14.7
Spill Time	August 1
Source of Spill	Guillotine break in export pipeline
Type of Spill	Instantaneous, guillotine rupture
Quantity of Oil Spilled	The RPS volume assumes an instantaneous guillotine rupture at milepost 14.7 of the pipeline. Adjusted RPS Volume = 428 bbl
Oil Type	Condensate
Wind Speed	20 knots
Wind Direction	Day 1: wind from SW Day 2 and beyond: wind from NE
Current	River has no significant net flow. Marine surface water flows 0.6 knots at 3 percent of wind speed.
Air Temperature	40°F
Trajectory	<p>Condensate falls from the pipeline break into the un-named creek that enters the Beaufort Sea 2.6 miles S of Bullen Point spit. Pipeline segment drains within 6 hours.</p> <p>The width of the condensate plume where it reaches the creek surface, 5 feet below the pipeline, is assumed narrower than the creek width.</p> <p>Condensate exits the pipeline rupture at the rate of 232 barrels per hour (bph) (163 gpm; 0.363 cubic feet per second). Condensate flows down the creek into the lagoon 2 miles N at that discharge rate. In the creek and lagoon on the first day of exposure, condensate becomes reduced to 40 percent of its original volume by evaporation. Condensate on the creek moves at 0.5 mph, reaching the lagoon in 4 hours. Over the 6 hours of the discharge, most of the un-evaporated condensate strands on the creek and lagoon shoreline gravel, soil, and vegetation.</p> <p>Before responders reach the site, most spilled condensate reaching the 1-mile-wide lagoon strands on its shoreline or escapes into Mikkelsen Bay where it moves northeastward at a speed of 0.6 knots.</p> <p>When the spill is detected and the pipeline is shut down at Hour 0 of the response, the wind blows from the SW and begins to push the condensate to the NE. Within 6 hours and 45 minutes, condensate begins stranding on the western end of Challenge Island.</p>

THIS PAGE INTENTIONALLY LEFT BLANK

**TABLE 1-10
CONDENSATE EXPORT PIPELINE SPILL TO OPEN WATER
RESPONSE STRATEGY**

ADEC REQUIREMENT	RESPONSE STRATEGY	ACS TECH. MANUAL TACTIC
(i) Stopping Discharge at Source	When the control room detects the immediate drop in pressure in the pipeline, the flow is shut down at the Central Well Pad (CWP) pumps and at the CWP and Badami tie-in valves.	Not applicable
(ii) Preventing or Controlling Fire Hazards	Throughout the first few hours of the response, the Site Safety Officer verifies that all sources of ignition are shut down or removed from the area. The Site Safety Officer provides access zone information and determines PPE requirements. Access to the spill site is carefully controlled and the scene is secured by Security. Monitoring protocol is established by the Site Safety Officer for all work areas to ensure personnel protection.	Not applicable
(iii) Well Control Plan	Not applicable	Not applicable
(iv) Surveillance and Tracking of Oil; Forecasting Shoreline Contact Points	Aerial observation with aircraft provides real-time tracking of the leading edge of the condensate. Tracking buoys are deployed from an ACS response skiff at the creek mouth at Hour 6 of the response.	T-4
	The National Oceanic and Atmospheric Administration (NOAA) is requested to provide trajectories based on wind speed and direction.	T-5
(v) Exclusion Procedures	The ACS <i>Technical Manual Map Atlas</i> , Sheets 98 and 101 are consulted to determine shoreline sensitivities and priority protection sites. No priority protection sites lie in the spill trajectory. The area is monitored for birds and mammals that may be at risk from the spill.	ACS Atlas Sheets 98 and 101 W-6
(vi) Spill Containment and Control Actions and (vii) Spill Recovery Procedures	Stream Task Force. Teams 1, 2, and 3 each deploy an exclusion boom and skimmer downstream of the pipeline crossing at Hour 8, following 1 hour for notification and site safety characterization, 1 hour to move, average 3 hours to travel, and 3 hours to deploy. Teams 1 and 2 use airboats from Point Thomson to travel up the creek 2 miles to the rupture site and a downstream control site. Team 3 from Endicott or West Dock sets up the third control site downstream. The objective is to contain and recover the spilled material close to its source to minimize spreading downstream. Marine Task Force. A marine team with a skimming vessel, boom towing skiff, freighter airboat, mini-barge, and boom deploys at Hour 6, following 1 hour for mobilization at Point Thomson dock, 3 hours to travel from Point Thomson, and 2 hours to deploy. The team travels 15 nautical miles (NM) from Point Thomson dock and targets floating condensate in the lagoon and in eastern Mikkelsen Bay. Over 3 days of response, the derated recovery capacity exceeds the RPS volume.	C-9 (3) R-8 (3) L-6 R-17 L-6
(viii) Lightering Procedures	No on-water lightering.	
(ix) Transfer and Storage of Recovered Oil/Water; Volume-Estimating Procedure	Marine Recovery Task Force. Condensate recovered by the marine on-water task force is pumped into mini-barges. A shuttle boat delivers an empty mini-barge and tows a loaded mini-barge an average 15 NM to Point Thomson dock for off-loading to vacuum trucks and temporary tanks. The number and turn-around time of mini-barges transfers stored liquid at a greater rate than it is collected and, consequently, transfer does not constrain the on-water recovery rates. Stream Task Force. Condensate recovered from the stream channel behind the three control site booms is stored in a Fold-a-Tank at each site. From the Fold-a-Tank, the liquid is pumped to a tank on an airboat and shuttled to Point Thomson dock. Stored condensate and water are hauled by vacuum truck to the slop oil tanks. Ullage tape and Coliwas tubes gauge liquid volumes and water cut in the mini-barges and vacuum trucks for waste manifests.	R-22 R-25 (3)

TABLE 1-10 (CONTINUED)
CONDENSATE EXPORT PIPELINE SPILL TO OPEN WATER
RESPONSE STRATEGY

ADEC REQUIREMENT	RESPONSE STRATEGY	ACS TECH. MANUAL TACTIC
(x) Plans, Procedures, and Locations for Temporary Storage and Disposal	Temporary storage facilities in bermed, lined pits are established at CPF pad and at the Bullen Point landing strip for oily wastes under a plan approved by the Unified Command and ADEC. Liquid and non-liquid wastes are characterized and disposed of accordingly.	D-1, D-2, D-3, D-4
(xi) Wildlife Protection Plan	Resources at risk are primarily birds. <ul style="list-style-type: none"> • The wildlife protection strategy is implemented. • Wildlife hazing teams are deployed on the creek and on oiled marine shorelines. • The Wildlife Stabilization Center is made operational at Deadhorse. • As oiled wildlife is identified, capture teams are deployed to the spill scene. • Captured birds are carried by wildlife response skiff to Point Thomson, where they are flown in fixed-wing aircraft to Deadhorse for treatment. 	W-1 W-2B W-5 W-3
(xii) Shoreline Cleanup Plan	Shoreline cleanup operations are initiated once the source of the condensate has been stopped, based on a plan approved by Unified Command. A shoreline assessment is conducted to understand the nature and extent of oiling. Based on shoreline assessment, priorities are established for cleanup. Cleanup techniques chosen are based on shoreline type and degree of oiling. Primary shoreline cleanup techniques would include: <ul style="list-style-type: none"> • Manual recovery of heavier pockets of condensate stranded along the shorelines. • Deluge of minor to moderately oiled shoreline in the river, including those areas where heavier concentrations were manually removed. • Mechanical removal at heavily oiled sites. • Natural recovery for those areas where residual staining may remain, but further recovery would cause more harm than good. 	SH-1 SH-2 through SH-11 SH-5 SH-3 SH-6 SH-2

**TABLE 1-11
CONDENSATE EXPORT PIPELINE SPILL TO OPEN WATER
OIL RECOVERY CAPACITY**

A	B	C	D	E	F	G
SPILL RECOVERY TACTIC	NUMBER OF SYSTEMS	RECOVERY SYSTEM	DERATED OIL RECOVERY RATE (boph)	MOBILIZATION, TRANSIT, AND DEPLOYMENT TIME TO SITE (hours)	OPERATING TIME (hours in a 24-hour shift)	DAILY DERATED OIL RECOVERY CAPACITY (bpd) (B x D x F)
R-8	3	Drum/Brush	28	7	20	1,680
R-17	1	Drum/Brush	28	6	20	560

boph bbl of oil per hour

**TABLE 1-12
CONDENSATE EXPORT PIPELINE SPILL TO OPEN WATER
LIQUID HANDLING CAPABILITY**

A	B	H	I	J	K	L	M	N	O	P
SPILL RECOVERY TACTIC	NUMBER OF STORAGE SYSTEMS	STORAGE CAPACITY DESCRIPTION	STORAGE CAPACITY (bbl)	OIL/ EMULSION AVAILABLE (bph)	TIME ON LOCATION BEFORE OFFLOAD NEEDED (hours) (I/J)	OFF-LOADING MECHANISM	OFF-LOADING RATE (bph)	TRANSIT TIME – BOTH WAYS (hours)	OFF-LOADING TIME (hours) (I/M)	OFF-LOAD AND TRANSIT TIME (hours) (N+O)
R-8, R-25	3	Fold-a-Tank	36	203 bbl / 3 teams / (72 hr – 8 hr) = 1 bph per tank	36	R-25, Fold-a-Tank via 2-inch pump to 300-gallon tank	312 ¹	6	0.1	6.1
R-17, R-22	1	Mini-Barge	237	203 / (72 hours – 6 hours) = 3.1 bph	76	R-22, to vacuum truck	158 ²	6.0	1.5	7.5

¹ Assumes 312 bph cited in R-25.

² Assumes 1.5 hours to off-load, following Assumption #23 in front of ACS *Technical Manual*.

TABLE 1-13
CONDENSATE EXPORT PIPELINE SPILL TO OPEN WATER
MAJOR EQUIPMENT EQUIVALENTS TO MEET THE RESPONSE PLANNING
STANDARD

TACTIC	NO. TACTICAL UNITS	EQUIPMENT PER TACTICAL UNIT	TOTAL QUANTITY
R-8, R-25	3	Delta Boom, 300 feet	900 feet
		Fold-a-Tank, 1 each	3
		Drum/Brush, 1 each	3
		Airboat, 1 each	3
		Pump, 1 each	3
R-17, R-22	1	Skimming Vessel with built-in recovery system and storage ¹	1
		Freighter Airboat for Shuttle	1
		Shallow Water Boom Towing Skiff	1
		Boom, 500 feet	500 feet
		Mini-Barge	2

¹ This piece of equipment will be listed in the ACS *Technical Manual* when it is purchased.

TABLE 1-14
CONDENSATE EXPORT PIPELINE SPILL TO OPEN WATER
EQUIPMENT FOR SHORELINE PROTECTION

TACTIC	NO. TACTICAL UNITS	EQUIPMENT PER TACTICAL UNIT	TOTAL QUANTITY
C-15	1	Workboat, Type A, 2 each	2
		Intertidal Boom and Delta Boom	5,300 feet

**TABLE 1-15
CONDENSATE EXPORT PIPELINE SPILL TO OPEN WATER
STAFFING TO OPERATE OIL RECOVERY AND TRANSFER EQUIPMENT**

LABOR CATEGORY	TACTIC	NO. TACTICAL UNITS	NO. STAFF PER UNIT	NO. STAFF PER SHIFT ¹
Team Lead	C-9, R-8	3	1	3
	R-17	1	1	1
	R-25	3	1	3
Large Vessel Operator	R-17 Skim Vessel and Shuttle	1	2	2
	R-25	3	1	3
Small Vessel Operator	R-17	1	1	1
Skilled Technician	C-9, R-8	3	4	12
	R-17	1	2	2
	R-25	3	1	3
General Technician	R-17	1	2	2
	R-25	3	2	6
Total Technicians ²	-	-	-	31

¹ The staffing schedule is shown in the column for number of staff per period. Number of staff recovering oil becomes zero after Hour 72.

² The total tallies the vessel operators and technicians. Team Leads operate vessels.

**TABLE 1-16
CONDENSATE EXPORT PIPELINE SPILL TO OPEN WATER
STAFFING FOR SHORELINE PROTECTION**

LABOR CATEGORY	TACTIC	NO. TACTICAL UNITS	NO. STAFF FOR SETUP	NO. STAFF PER UNIT	NO. STAFF PER SHIFT
Team Lead	C-15	1	1	1	1
Small Vessel Operator		1	2	2	2
Skilled Tech		1	3	1	1
Total ¹	-	-	5	3	3

¹ The total tallies the operators and technicians. Team Leads operate vessels.

THIS PAGE INTENTIONALLY LEFT BLANK

**FIGURE 1-6 CONDENSATE EXPORT PIPELINE SPILL TO OPEN WATER SCENARIO
VICINITY MAP**

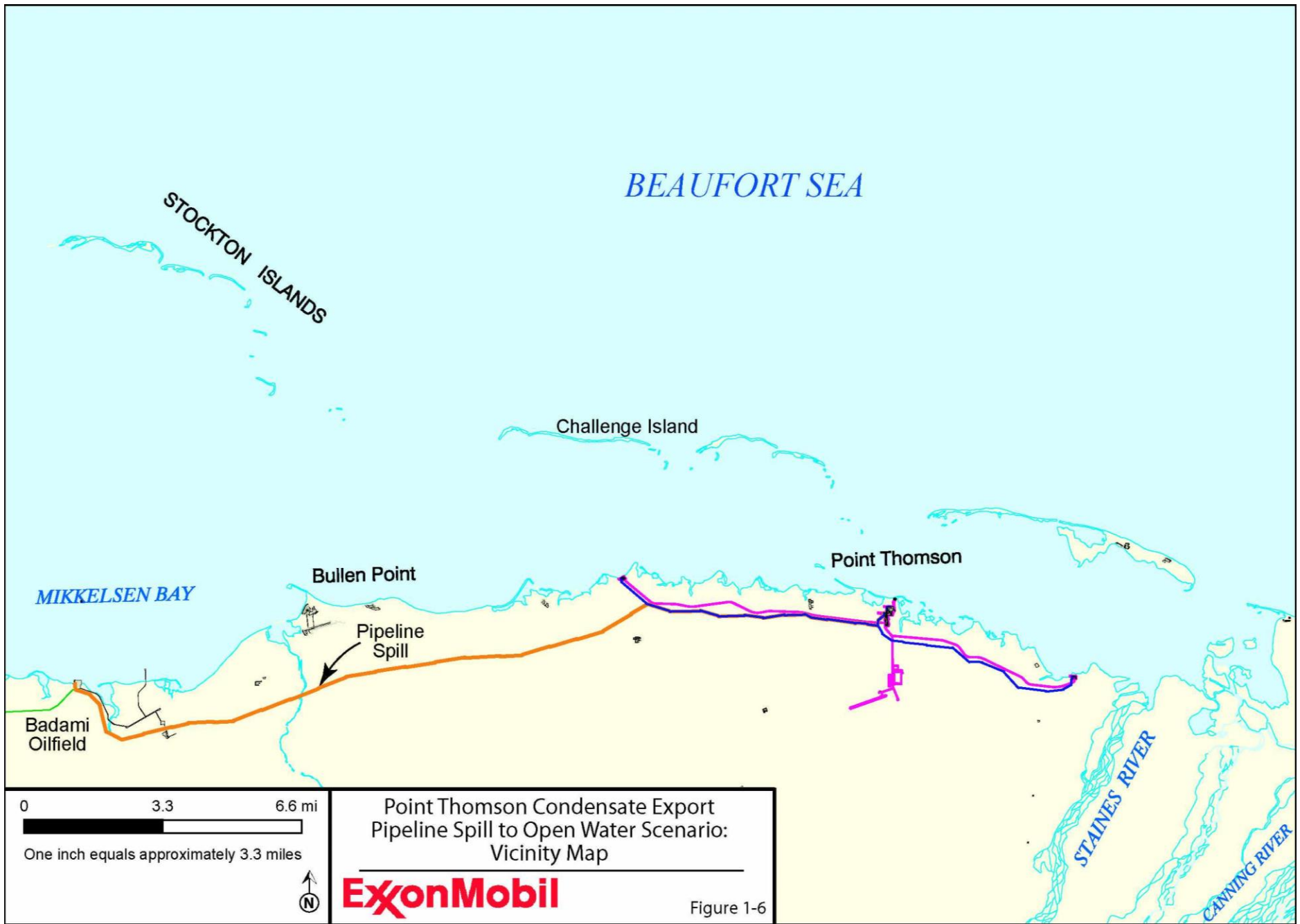
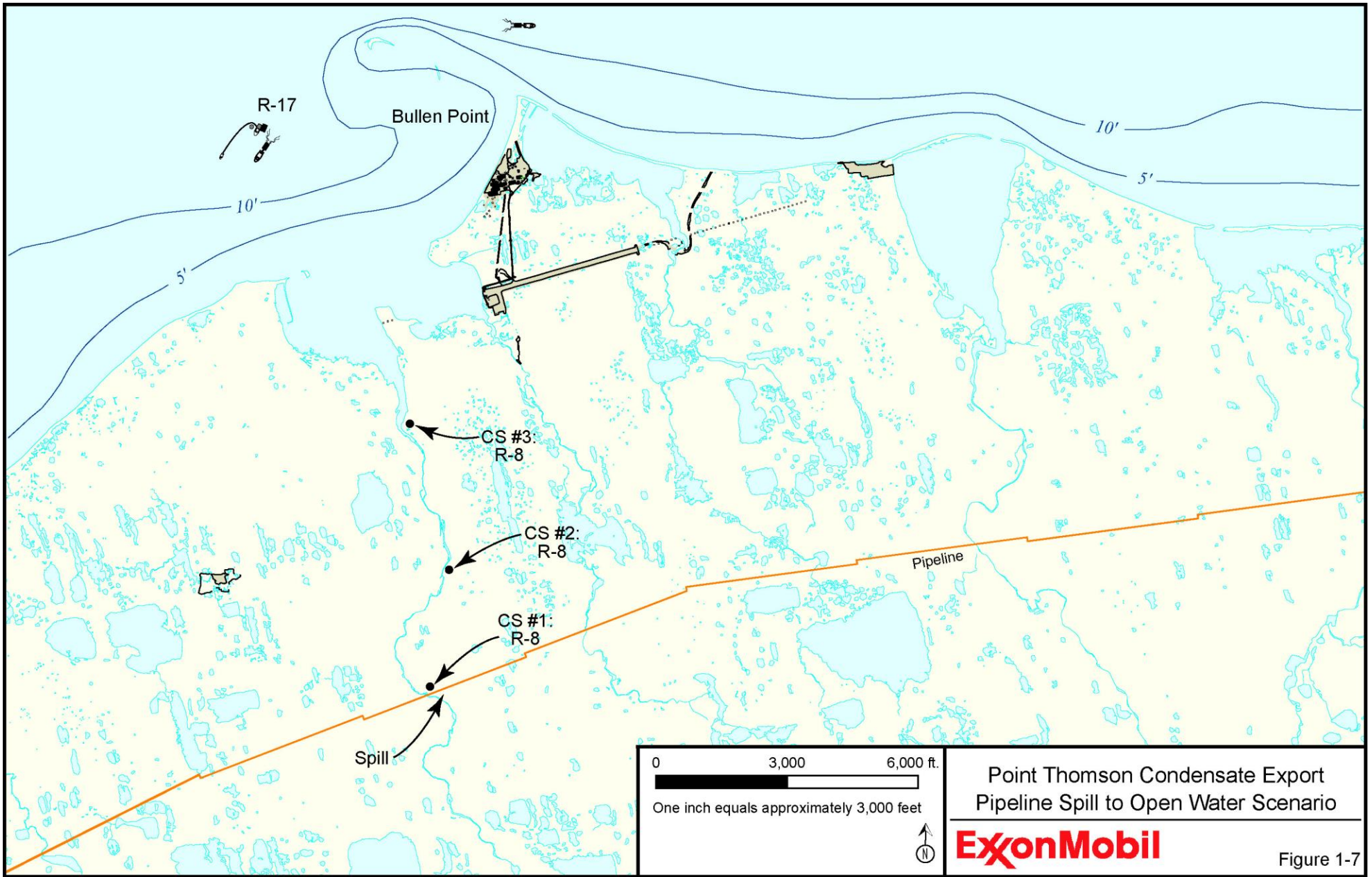

FIGURE 1-7 CONDENSATE EXPORT PIPELINE SPILL TO OPEN WATER SCENARIO



Point Thomson Condensate Export Pipeline Spill to Open Water Scenario



Figure 1-7

SCENARIO 2

POINT THOMSON CONDENSATE EXPORT PIPELINE SPILL DURING BREAK-UP

THIS PAGE INTENTIONALLY LEFT BLANK

**TABLE 1-17
CONDENSATE EXPORT PIPELINE SPILL DURING BREAK-UP
SCENARIO CONDITIONS**

PARAMETER	PARAMETER CONDITIONS
Spill Location	Condensate export oil pipeline crossing of un-named creek near pipeline milepost 14.7
Spill Time	June 1
Source of Spill	Guillotine break in condensate export pipeline
Type of Spill	Instantaneous guillotine rupture
Quantity of Oil Spilled	Adjusted RPS Volume = 428 bbl
Oil Type	Condensate
Wind Speed	20 knots
Wind Direction	Day 1: wind from SW Day 2 and beyond: wind from NE
Current	Stream flows 2.5 mph at peak flow. Lagoon frozen, overflow water has a wind-induced current of 0.6 knots at 3 percent of wind speed.
Air Temperature	35°F
Surface	Stream carries water and ice. Lagoon is ice-covered with overflow water accumulating near shore.
Trajectory	<p>Condensate falls from the pipeline break into the un-named creek that enters the Beaufort Sea 2.6 miles S of Bullen Point spit. Pipeline segment drains within 6 hours.</p> <p>The width of the condensate plume where it reaches the creek surface, 5 feet below the pipeline, is assumed narrower than the creek width.</p> <p>Condensate exits the pipeline rupture at the rate of 232 bph (163 gpm; 0.363 cubic feet per second). Condensate flows down the creek into the lagoon 2 miles N at that discharge rate. Condensate on the creek moves at 2.5 mph, reaching the lagoon in 48 minutes. Lifted by the rising stream, the un-evaporated condensate moves onto the overflow waters. In the creek and lagoon estuary, on the first day of exposure, condensate becomes reduced to 40 percent of its original volume by evaporation. By Hour 7, virtually all of the condensate has left the river and entered the lagoon with overflow waters.</p> <p>The floating condensate reaching the 1-mile-wide estuary is pushed by the prevailing SW wind towards the eastern shoreline of the estuary.</p> <p>One day after the spill is reported, the wind shifts to the NE and begins to push condensate in the lagoon estuary towards the SW shoreline.</p>

THIS PAGE INTENTIONALLY LEFT BLANK

**TABLE 1-18
CONDENSATE EXPORT PIPELINE SPILL DURING BREAK-UP
RESPONSE STRATEGY**

ADEC REQUIREMENT	RESPONSE STRATEGY	ACS TECH. MANUAL TACTIC
(i) Stopping Discharge at Source	When the control room detects the immediate drop in pressure in the pipeline, the flow is shut down at the CWP pumps and at the CWP and Badami valves. The pipeline is completely shut down in 8 minutes.	Not applicable
(ii) Preventing or Controlling Fire Hazards	Throughout the first few hours of the response, the Site Safety Officer verifies that all sources of ignition are shut down or removed from the area. The Site Safety Officer provides access zone information and determines PPE requirements. Access to the spill site is carefully controlled and the scene is secured by Security. Monitoring protocol is established by the Site Safety Officer for all work areas to ensure personnel protection.	S-1 through S-6
(iii) Well Control Plan	Not applicable	Not applicable
(iv) Surveillance and Tracking of Oil; Forecasting Shoreline Contact Points	Aerial observation with aircraft provides real-time tracking of the leading edge of the oil. Tracking buoys are deployed from an ACS airboat at the creek mouth at Hour 6 of the response.	T-4
(v) Exclusion Procedures	Potential impact areas and priority protection sites are identified with slick trajectory calculation, <i>ACS Technical Manual, Volume 2, Map Atlas</i> maps, and Alaska Regional Response Team's (ARRT's) <i>North Slope Sub-Area Plan Areas of Major Concern</i> . No priority protection sites are identified within the area of impact. A Shoreline Task Force member helps direct response workers away from cultural sites, based on a shoreline cleanup plan approved by the State Historic Preservation Officer and the Unified Command. A forward staging area is set up at the western end of the Bullen Point airstrip.	L-2
(vi) Spill Containment and Control Actions and (vii) Spill Recovery Procedures	Stream Task Force. High and fluctuating stream levels, moving ice, and high-stream flow speeds make mechanical containment and recovery infeasible within the stream. The riverbanks are still ice-covered and virtually all of the condensate enters the lagoon within 7 hours of the rupture. Marine Task Force. A marine team with a 30-foot freighter airboat and mounted 300-gallon DOT tank, and two 20-foot airboats, skimmer, and boom begins recovery at Hour 6, following 1 hour for mobilization at Point Thomson dock, 3 hours to travel from Point Thomson, and 2 hours to deploy. The freighter airboat also mobilizes five 1,500-gallon Fold-a-Tanks from the CWP and Western Exploration Pad at Point Thomson. The team travels 15 NM from Point Thomson dock and targets floating condensate in the overflow water in the lagoon. A second freighter airboat with a mounted 300-gallon DOT tank mobilized from Endicott deploys at Hour 4 and travels 30 NM in 6 hours to arrive on-site at Hour 10. A 10,000-gallon bladder tank stored at the Point Thomson Exploration Pad is assembled at the west end of the Bullen Point airstrip. The combined capacity of the Fold-a-Tanks and the 10,000-gallon bladder tank is 17,500 gallons, or 416 bbl. Over 3 days of response, the derated recovery capacity and storage exceeds the RPS volume.	L-7 R-25 R-17 L-6
(viii) Lightering Procedures	No lightering is anticipated.	
(ix) Transfer and Storage of Recovered Oil/Water; Volume-Estimating Procedure	Marine Recovery Task Force. Condensate recovered by the marine on-water task force is pumped into the 300-gallon DOT tanks on the two freighter airboats. The airboats haul recovered condensate to the eastern shore of the lagoon where five 1,500-gallon Fold-a-Tanks and a 10,000-gallon bladder tank are erected on the Bullen Point landing strip. The freighters are offloaded with a 2-inch trash pump. Ullage tape and Coliwasas gauge liquid volumes and water cut in the tanks.	R-25

TABLE 1-18 (CONTINUED)
CONDENSATE EXPORT PIPELINE SPILL DURING BREAK-UP
RESPONSE STRATEGY

ADEC REQUIREMENT	RESPONSE STRATEGY	ACS TECH. MANUAL TACTIC
(x) Plans, Procedures, and Locations for Temporary Storage and Disposal	Temporary storage facilities in bermed, lined pits are established at CPF pad and at the Bullen Point landing strip for oily wastes under a plan approved by the Unified Command and ADEC. Liquid and non-liquid wastes are characterized and disposed of accordingly.	D-1, D-2, D-3, D-4
(xi) Wildlife Protection Plan	Resources at risk are primarily birds. <ul style="list-style-type: none"> • The wildlife protection strategy is implemented. • Wildlife hazing teams are deployed on the creek and on oiled marine shorelines if the shorelines are ice-free. • The Wildlife Stabilization Center is made operational at Deadhorse. • As oiled wildlife are identified, capture teams are deployed to the spill scene. • Captured birds are carried by wildlife response skiff to Point Thomson, where they are flown in fixed-wing aircraft to Deadhorse for treatment. 	W-1 W-2B W-5 W-3
(xii) Shoreline Cleanup Plan	Shoreline cleanup operations are initiated once the source of the oil has been stopped, based on a plan approved by Unified Command. A shoreline assessment is conducted to understand the nature and extent of oiling. Based on shoreline assessment, priorities are established for cleanup. Cleanup techniques chosen are based on shoreline type and degree of oiling. Primary shoreline cleanup techniques would include: <ul style="list-style-type: none"> • Manual recovery of heavier pockets of oil stranded along the shorelines • Deluge of minor to moderately oiled shoreline in the river, including those areas where heavier concentrations were manually removed • Mechanical removal at heavily oiled sites • Natural recovery for those areas where residual staining may remain, but further recovery would cause more harm than good 	SH-1 SH-2 through SH-11 SH-5 SH-3 SH-6 SH-2

**TABLE 1-19
CONDENSATE EXPORT PIPELINE SPILL DURING BREAK-UP
OIL RECOVERY CAPACITY**

A	B	C	D	E	F	G
SPILL RECOVERY TACTIC	NUMBER OF SYSTEMS	RECOVERY SYSTEM	DERATED OIL RECOVERY RATE (boph)	MOBILIZATION, TRANSIT AND DEPLOYMENT TIME TO SITE (hours)	OPERATING TIME (hours in a 24-hour shift)	DAILY DERATED OIL RECOVERY CAPACITY (bpd) (B x D x F)
R-17	1	Drum/Brush	28	6	20	560

**TABLE 1-20
CONDENSATE EXPORT PIPELINE SPILL DURING BREAK-UP
LIQUID HANDLING CAPABILITY**

A	B	H	I	J	K	L	M	N	O	P
SPILL RECOVERY TACTIC	NUMBER OF STORAGE SYSTEMS	STORAGE CAPACITY DESCRIPTION	STORAGE CAPACITY (bbl)	OIL/ EMULSION AVAILABLE (bph)	TIME ON LOCATION BEFORE OFFLOAD NEEDED (hours) (I/J)	OFF-LOADING MECHANISM	OFF-LOADING RATE (bph)¹	TRANSIT TIME – BOTH WAYS (hours)	OFF-LOADING TIME (hours) (I/M)	OFF-LOAD AND TRANSIT TIME (hours) (N+O)
R-17	2	300-gallon DOT tanks	7.1 / tank	428 / 2 tanks (72 hr – 6 hr) = 3.2 bph per tank	2	R-25	312	0.5	0.05	0.55

¹ Assumes 2-inch Trash pump rated at 312 bph

**TABLE 1-21
CONDENSATE EXPORT PIPELINE SPILL DURING BREAK-UP
MAJOR EQUIPMENT EQUIVALENTS TO MEET THE RESPONSE PLANNING
STANDARD**

TACTIC	NO. TACTICAL UNITS	EQUIPMENT PER TACTICAL UNIT	TOTAL QUANTITY
R-17	1	Skimmer	1
		Airboat to tow boom and operate skimmer and pump	1
		Boom-Towing Airboat	1
		Boom	500 feet
R-25	2	Freighter Airboat (acts as shuttle for R-17)	2
		300-gallon DOT tank	2

**TABLE 1-22
CONDENSATE EXPORT PIPELINE SPILL DURING BREAK-UP
STAFFING TO OPERATE OIL RECOVERY AND TRANSFER EQUIPMENT**

LABOR CATEGORY	TACTIC	NO. TACTICAL UNITS	NO. STAFF PER UNIT	NO. STAFF PER SHIFT ¹
Team Lead	R-17	1	1	1
	R-25	2	1	2
Large Vessel Operator	R-17	1	1	1
	R-25	2	1	2
Small Vessel Operator	R-17	1	1	1
Skilled Technician	R-17	1	2	2
	R-25	2	1	2
General Technician	R-17	1	2	2
	R-25	2	2	4
Total Technicians ²	-	-	-	14

¹ The staffing schedule is shown in the column for number of staff per period. Number of staff recovering oil becomes zero after Hour 72.

² The total tallies the vessel operators and technicians. Team Leads operate vessels.

**FIGURE 1-8 CONDENSATE EXPORT PIPELINE SPILL DURING BREAK-UP
SCENARIO VICINITY MAP**

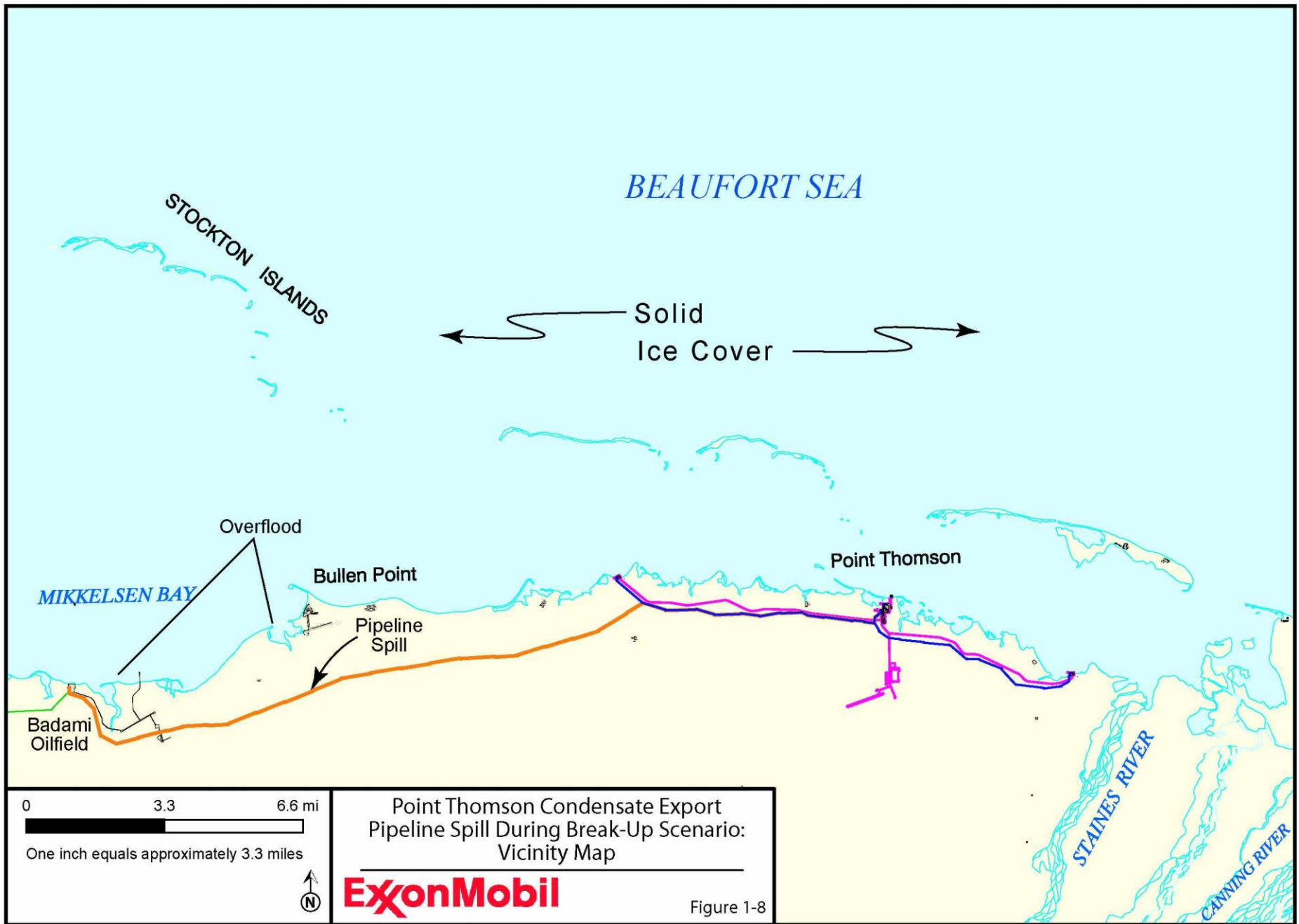

**FIGURE 1-9 CONDENSATE EXPORT PIPELINE SPILL DURING BREAK-UP
SCENARIO**

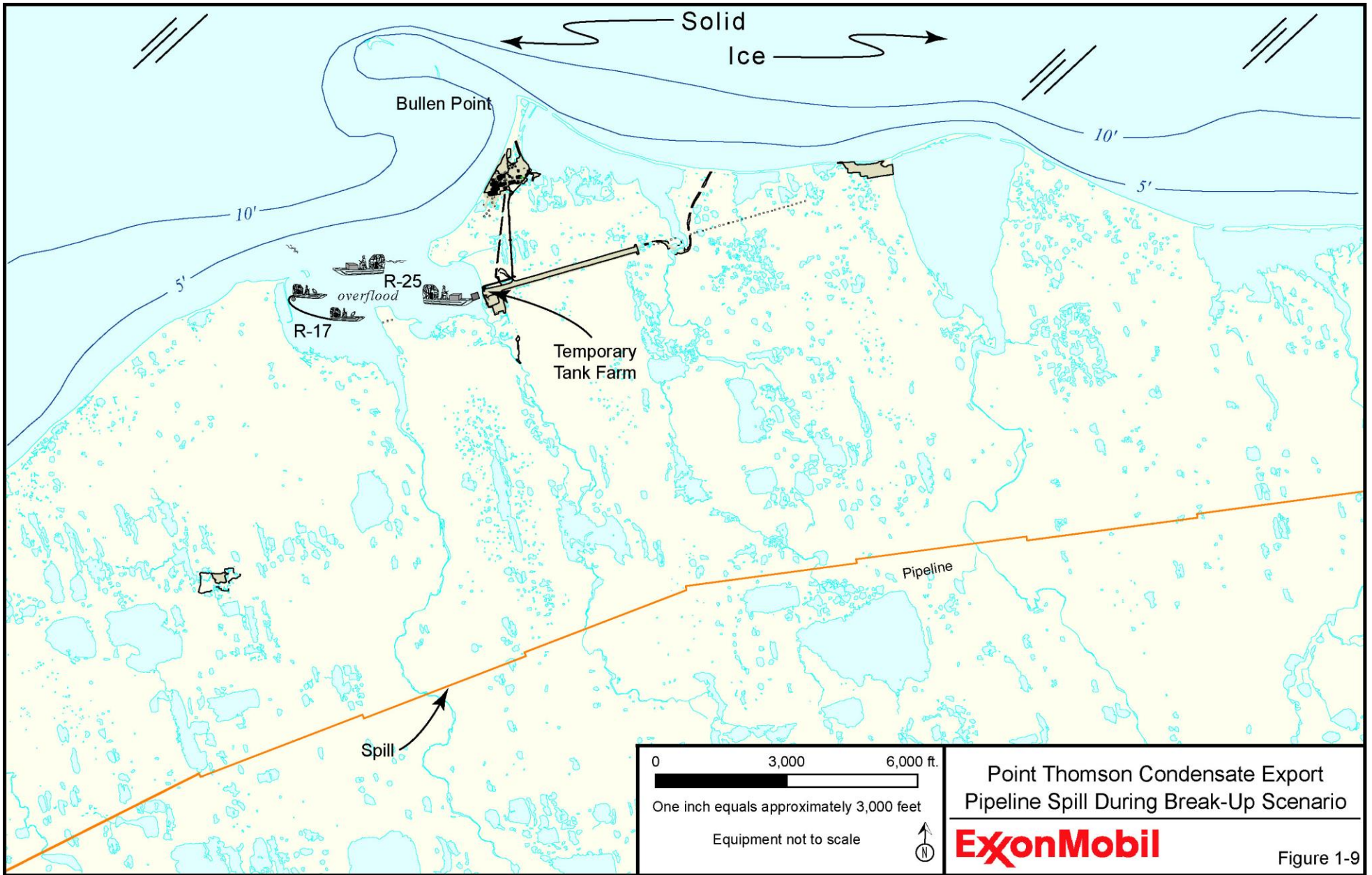

Point Thomson Condensate Export Pipeline Spill During Break-Up Scenario



Figure 1-9

SCENARIO 3

POINT THOMSON DIESEL TANK RUPTURE DURING SUMMER

THIS PAGE INTENTIONALLY LEFT BLANK

**TABLE 1-23
DIESEL TANK RUPTURE DURING SUMMER
SCENARIO CONDITIONS**

PARAMETER	PARAMETER CONDITIONS
Spill Location	Diesel fuel storage tank at CPF
Date	Summer
Duration	Instantaneous
Type of Spill	Catastrophic tank rupture
Emulsification Factor (Applicable to oil that reaches open water, for storage purposes)	Not applicable
Quantity of Oil Spilled	<p>Adjusted RPS Volume = 2,733 bbl</p> <p>Volume retained in gravel = $(3,844 \text{ square feet gravel} \times 0.5 \text{ gallons per square foot}) / 42 \text{ gallons per bbl} = 45 \text{ bbl in gravel}$</p> <p>Volume retained in tundra =</p> <ol style="list-style-type: none"> 1. Area in which off-pad diesel will be retained = $(\text{Adjusted RPS Volume}) - (\text{Volume retained in gravel}) \times (42 \text{ gallons per bbl}) / (\text{retention rate of } 3 \text{ gallons per square foot}) = 37,632 \text{ square feet or an approximate } 194\text{-foot by } 194\text{-foot area.}$ 2. One pond and half the area of another small pond falls within this off-pad zone; the pond areas are subtracted from the total affected tundra area = $(37,632 \text{ square feet}) - (13,125 \text{ square feet of pond one}) - [(7,850 \text{ square feet of pond two}) / 2] = 20,582 \text{ square feet.}$ 3. Convert the affected tundra area (less the area of the ponds) into bbl, assuming diesel retention rate of 3 gallons / square foot = $16,760 \text{ square feet} \times (3 \text{ gallons} / \text{square foot}) / 42 \text{ gallons per bbl} = 1,470 \text{ bbl in tundra.}$ <p>Volume entering ponds = $(\text{Adjusted RPS Volume} - \text{Volume retained in gravel} - \text{Volume retained in tundra}) = (2,733 \text{ bbl} - 45 \text{ bbl} - 1,470 \text{ bbl}) = 1,218 \text{ bbl on ponds.}$</p>
Oil Type	Arctic diesel
Wind Speed	20 knots
Wind Direction	Day 1: wind from the SW Day 2+: wind from the NE
Current	Not applicable
Air Temperature	40°F
Trajectory	<p>The majority of the diesel is contained within the tank's interstitial space. Approximately 1,890 gallons (45 bbl) are retained in the 62-foot x 62-foot gravel area crossed by the spilled diesel between the tank farm and the edge of the pad. Approximately 61,740 gallons (1,470 bbl) are retained in the 194-foot by 194-foot area of tundra over which the diesel flows. The remaining diesel enters one pond just off the pad and also impacts the east side of a second small pond west of the pad at the same rate the tundra retains the diesel (tundra retains at 3 gallons per square foot).</p> <p>Immediately the wind blows the diesel to the NE shore of the ponds.</p> <p>For the purposes of the scenario, recovery rates and stored volumes are assumed un-affected by evaporation losses or emulsification.</p>

THIS PAGE INTENTIONALLY LEFT BLANK

**TABLE 1-24
DIESEL TANK RUPTURE DURING SUMMER
RESPONSE STRATEGY**

ADEC REQUIREMENT	RESPONSE STRATEGY	ACS TECH. MANUAL TACTIC
(i) Stopping Discharge at Source	To prevent further diesel from entering the tank, the loading line valve is closed and the pump is tagged and locked out.	Not applicable
(ii) Preventing or Controlling Fire Hazards	<ul style="list-style-type: none"> • The supervisor immediately shuts down nearby ignition sources. • The Fire Chief is on the scene with equipment and personnel to suppress the threat of an explosion. Throughout the first few hours of the spill, the Fire Chief verifies that sources of ignition are shut down or removed from the area. • The Site Safety Officer provides access zone information and determines PPE requirements. Access to the spill site is controlled and the scene is secured by Security. Monitoring protocol is established by the Site Safety Officer for work areas to ensure personnel protection. 	S-1 through S-6
(iii) Well Control Plan	Not applicable	
(iv) Surveillance and Tracking of Oil	A survey crew delineates the spill-affected area at CPF and vicinity. An aircraft records infrared readings and visual observations of the diesel.	T-2
(v) Exclusion Procedures	The ACS <i>Technical Manual, Volume 2, Map Atlas</i> , Sheet 103, is consulted to determine shoreline sensitivities and priority protection sites. No priority protection sites lie in the spill trajectory. The area is monitored for birds and mammals that may be at risk from the spill.	ACS Atlas Map 103 W-6
(vi) Spill Containment and Control Actions and (vii) Spill Recovery Procedures	<p>CPF and Tundra Task Force</p> <ul style="list-style-type: none"> • A staging area and field command post are set up at the CPF in the parking area located east of Building 201. • After the decontamination area is set up, Team 1 places shoreseal boom and sorbent boom on the perimeter of the contaminated tundra to deflect and contain diesel. • Team 1 also constructs gravel berms on the pad to ensure that the diesel remains trapped in the immediate areas and depressions. • Team 2 cleans the tundra and gravel. Crews flush low-pressure water over the tundra, moving diesel down to collection areas where it is recovered with vacuum truck hoses and sorbent material. Vacuum trucks collect from a position near the edge of the pad, with Manta Ray skimmer heads attached to intake hoses. • After liquids are removed, grid sampling indicates the depth of gravel penetration, and Team 3 excavates the contaminated gravel. The contaminated gravel is transported to a lined containment area south of Central Storage and stored for later handling. • Contaminated vegetation is left in place. Some is burned to reduce re-oiling of adjacent habitat. <p>Pond Task Force</p> <ul style="list-style-type: none"> • Containment boom is deployed at the eastern shore of the ponds to contain diesel being flushed from the tundra by Team 2. • Diesel is recovered from the boomed areas with a vacuum truck and Manta Ray skimmer. <p>The pond task force recovery effort begins once the on-site equipment is mobilized to the pond (at Hour 1). The pond and tundra recovery teams have the ability to recover diesel at the de-rated capacity of 27 bph through Hour 72, a volume greater than the adjusted RPS volume portion entering the ponds. The vacuum trucks are stationed near the edge of the pad, with a 200-foot hose that reaches both impacted ponds and tundra.</p>	L-2 C-4 R-4, R-6 R-26 B-1, B-2 C-5 R-6
(viii) Lightering Procedures	Not applicable	Not applicable

**TABLE 1-24 (CONTINUED)
DIESEL TANK RUPTURE DURING SUMMER
RESPONSE STRATEGY**

ADEC REQUIREMENT	RESPONSE STRATEGY	ACS TECH. MANUAL TACTIC
(ix) Transfer and Storage of Recovered Oil/Water; Volume-Estimating Procedure	<ul style="list-style-type: none"> • Recovered diesel and water are hauled by vacuum truck across the pad to the facility's liquid process tanks for processing. Processed liquids are manifested. Oily sorbents are hauled by ATV on plywood paths to the pad. • Diesel volume in solids is estimated with grab samples. • The amount of diesel contained in 3,844 square feet of gravel pad is 45 bbl. At the rate of 8 cubic yards of gravel per bbl, 360 cubic yards of oily gravel are stockpiled for treatment. 	<p align="center">D-1 R-6 R-5</p>
(x) Plans, Procedures, and Locations for Temporary Storage and Disposal	<ul style="list-style-type: none"> • Oily liquids are recycled in the processing facility. • Non-liquid oily wastes are classified and disposed of according to classification. • Non-oily wastes are classified and disposed of accordingly. • Oiled gravel is excavated and treated under a contaminated soil stockpile treatment plan approved by ADEC. 	<p align="center">D-1 D-2 D-3 D-4</p>
(xi) Wildlife Protection Plan	<ul style="list-style-type: none"> • The wildlife protection strategy is implemented. • A bird-hazing team deploys passive hazing devices at the ponds beginning on the first shift. • The Wildlife Stabilization Center is made operational in Deadhorse. No oiled animals are encountered. 	<p align="center">W-1 W-2B W-5</p>
(xii) Shoreline and Tundra Cleanup	<ul style="list-style-type: none"> • The shoreline is cleaned up to the satisfaction of ADEC in the shortest possible time with teams of shoreline cleanup crews and equipment. Oily waste is hauled to a controlled and lined collection area on the pad, south of Central Storage. • Heavier pockets of stranded diesel are collected manually. • Minor to moderately oiled areas are deluged to recover diesel. 	<p align="center">SH-1 SH-5 SH-3</p>

**TABLE 1-26
DIESEL TANK RUPTURE DURING SUMMER
OIL RECOVERY CAPACITY**

A	B	C	D	E	F	G
SPILL RECOVERY TACTIC	NUMBER OF SYSTEMS	RECOVERY SYSTEM	DERATED OIL RECOVERY RATE (boph)	MOBILIZATION, TRANSIT, AND DEPLOYMENT TIME TO SITE (hours)	OPERATING TIME (hours in a 24-hour shift)	DAILY DERATED OIL RECOVERY CAPACITY (bpd) (B x D x F)
R-6	2	Vacuum Truck with Manta Ray Skimmer	27	1.5	16 ¹	864

¹ Truck operates 20 hours per day, but 16 hours per day are spent recovering and 4 hours per day are needed for offloading.

**TABLE 1-27
DIESEL TANK RUPTURE DURING SUMMER
LIQUID HANDLING CAPABILITY**

A	B	H	I	J	K	L	M	N	O	P
SPILL RECOVERY TACTIC	NUMBER OF STORAGE SYSTEMS	STORAGE CAPACITY DESCRIPTION	STORAGE CAPACITY (bbf)	OIL/EMULSION AVAILABLE (bph)	TIME ON LOCATION BEFORE OFFLOAD NEEDED (hours) (I/J)	OFFLOADING MECHANISM	OFF-LOADING RATE (bph)	TRANSIT TIME – BOTH WAYS (hours)	OFF-LOADING TIME (hours) (I/M)	OFFLOAD AND TRANSIT TIME (hours) (N+O)
R-6	2	Vacuum Truck	100 each	27 ¹	3.7 ²	Vacuum truck	200	0.5	0.5	1

¹ The total volume of diesel and free water available for storage is the recovered volume of diesel using a Manta Ray. Emulsification is not a factor.

² Time before offload is needed assumes a maximum de-rated recovery rate of 27 bph for a Manta Ray skimmer.

**TABLE 1-28
DIESEL TANK RUPTURE DURING SUMMER
MAJOR EQUIPMENT FOR RECOVERY AND TRANSFER**

TACTIC	NO. TACTICAL UNITS	EQUIPMENT PER TACTICAL UNIT	TOTAL QUANTITY
R-4	1	Fold-a-Tank	3
		Trash Pump	1
		Suction and Discharge Hose	variable
		Shore Seal Boom (1000 feet)	1000 feet
R-6	2	Vacuum Truck	2
		Manta Ray Skimmer Head	2
R-26	1	Front-end Loader	1

**TABLE 1-29
DIESEL TANK RUPTURE DURING SUMMER
STAFFING TO OPERATE OIL RECOVERY AND TRANSFER EQUIPMENT**

LABOR CATEGORY	TACTIC	NO. TACTICAL UNITS	NO. STAFF PER UNIT	NO. STAFF PER SHIFT ¹
Team Lead	R-4	1	1	1
	R-6	2	1	2
Skilled Technician	R-4	1	1	1
	R-6	2	2	4
General Technician	R-4	1	1	1
	R-6	2	1	2
Equipment Operators	R-6	2	1	2
	R-26	1	1	1
Total Technicians and Laborers ²	-	-	-	8

¹ The staffing schedule is shown in the column for number of staff per period. Number of staff recovering oil becomes zero after Hour 72.

² The total tallies the technicians and laborers. Team Leads are Skilled Technicians.

FIGURE 1-10 DIESEL TANK RUPTURE DURING SUMMER VICINITY MAP

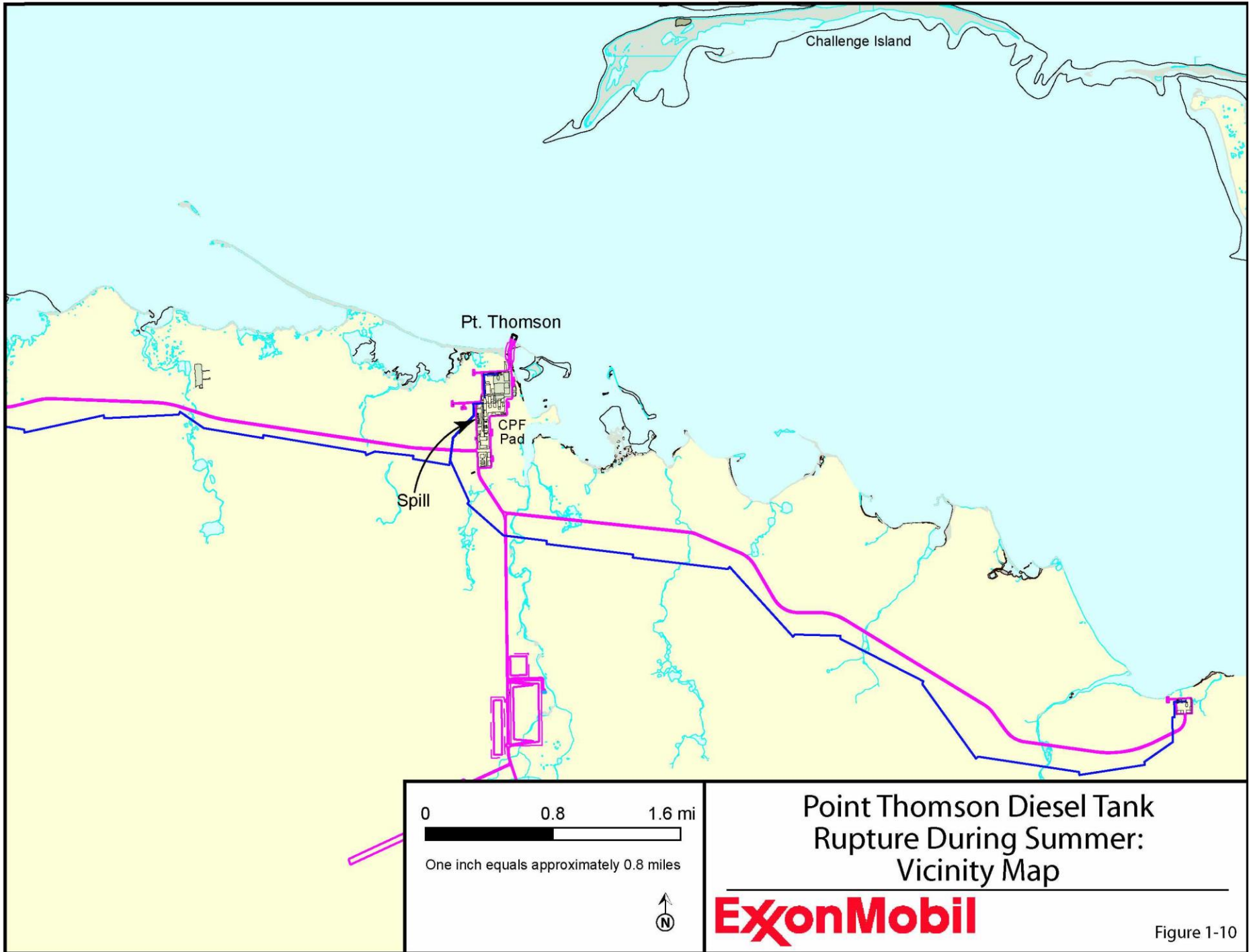
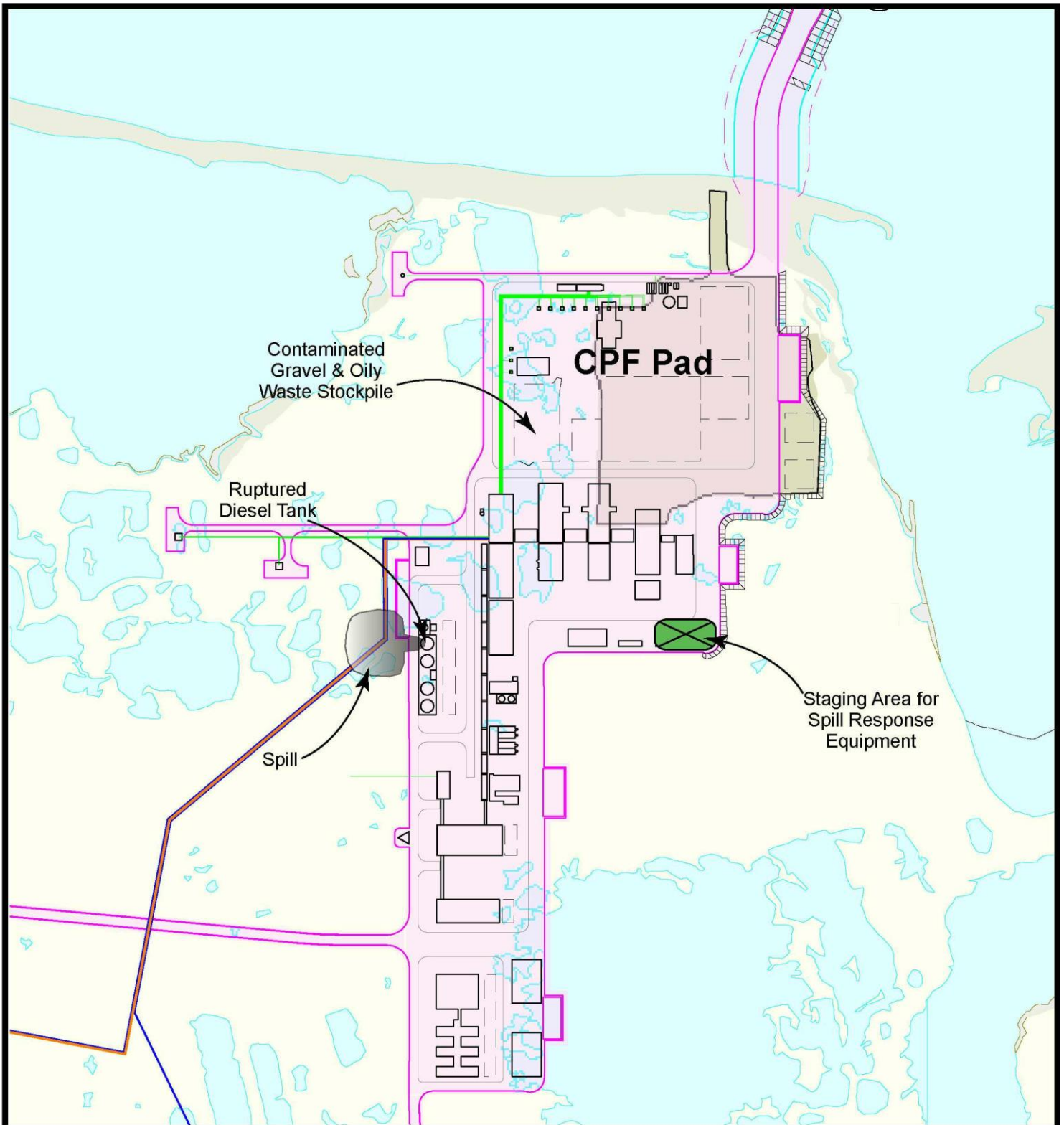

FIGURE 1-11 DIESEL TANK RUPTURE DURING SUMMER



0 450 900 ft.
 one inch equals approximately 450 feet



Point Thomson Diesel Tank Rupture During Summer

ExxonMobil

Figure 1-11

SCENARIO 4

POINT THOMSON DIESEL TANK RUPTURE DURING FREEZE-UP

THIS PAGE INTENTIONALLY LEFT BLANK

**TABLE 1-30
DIESEL TANK RUPTURE DURING FREEZE-UP
SCENARIO CONDITIONS**

PARAMETER	PARAMETER CONDITIONS
Spill Location	Diesel fuel storage tank at the CPF
Date	October
Duration	Instantaneous
Type of Spill	Catastrophic tank rupture
Emulsification Factor (Applicable to oil that reaches open water, for storage purposes)	Not applicable
Quantity of Oil Spilled	<p>Adjusted RPS Volume = 2,733</p> <p>Volume retained in gravel = (3,844 square feet gravel x 0.5 gallons per square foot) / 42 gallons per bbl) = 45 bbl in gravel</p> <p>Volume retained in tundra snow =</p> <ol style="list-style-type: none"> 1. Area in which off-pad diesel will be retained = (Adjusted RPS Volume) - (Volume retained in gravel) x (42 gallons per bbl) / (Tactic R-3 retention rate of 3.7 gallons per cubic foot) = 30,512 cubic feet; with diesel spreading in the top 6 inches of snow = (30,512 cubic feet volume of affected snow) / (0.5 foot) = 61,025 square feet or a 250-foot by 250-foot area. 2. Two ponds fall within this off-pad zone; the pond areas are subtracted from the total affected tundra area = (61,025 square feet) – (13,125 square feet of pond one) – (7,850 square feet of pond two) = 40,050 square feet; convert to cubic feet of snow at a 6-inch depth = (40,050 square feet x 0.5 foot) = 20,025 cubic feet. 3. Convert the affect tundra area (less the area of the ponds) into bbl, assuming diesel retention rate of 3.7 gallons per cubic foot = (20,025 cubic feet) x (3.7 gallons per cubic foot) / (42 gallons per bbl) = 1,764 bbl in tundra snow. <p>Volume retained by pond snow and ice = (Adjusted RPS Volume – Volume retained in gravel – Volume retained in tundra) = (2,733 bbl – 45 bbl – 1,764 bbl) = 924 bbl on pond snow and ice.</p>
Oil Type	Arctic diesel
Wind Speed	20 knots
Wind Direction	Day 1: wind from the SW Day 2+: wind from the NE
Current	Not applicable
Air Temperature	14°F
Trajectory	<p>The majority of the diesel is contained within the tank's interstitial space. Approximately 1,890 gallons (45 bbl) are retained in the 62-foot by 62-foot gravel area crossed by the spilled diesel between the tank farm and the edge of the pad. Approximately 74,088 gallons (1,764 bbl) are retained in the 250-foot by 250-foot area of snow-covered tundra and ponds over which the diesel flows. A portion of the diesel encounters one pond just off the pad and also impacts a second small pond west of the pad at the same rate the tundra snow retains the diesel (tundra snow retains the diesel at 3.7 gallons per cubic foot; see Tactic R-3). Diesel is retained in the snow to a maximum depth of 3 inches.</p> <p>Immediately, the wind blows any free diesel to the NE icy shore of the ponds where it is contained among broken ice chunks. As the ponds freeze, diesel becomes embedded in the ice and does not weather.</p> <p>For the purposes of the scenario, recovery rates and stored volumes are assumed un-affected by evaporation losses or emulsification.</p>

THIS PAGE INTENTIONALLY LEFT BLANK

**TABLE 1-31
DIESEL TANK RUPTURE DURING FREEZE-UP
RESPONSE STRATEGY**

ADEC REQUIREMENT	RESPONSE STRATEGY	ACS TECH. MANUAL TACTIC
(i) Stopping Discharge at Source	To prevent further diesel from entering the tank, the loading line valve is closed and the pump is tagged and locked out.	Not applicable
(ii) Preventing or Controlling Fire Hazards	<ul style="list-style-type: none"> • The Supervisor immediately shuts down nearby ignition sources. • The Fire Chief is on the scene with equipment and personnel to suppress the threat of an explosion. Throughout the first few hours of the spill, the Fire Chief verifies that sources of ignition are shut down or removed from the area. • The Site Safety Officer provides access zone information and determines PPE requirements. Access to the spill site is controlled and the scene is secured by Security. Monitoring protocol is established by the Site Safety Officer for work areas to ensure personnel protection. 	S-1 through S-6
(iii) Well Control Plan	Not applicable	
(iv) Surveillance and Tracking of Oil	The extent of the diesel is marked on the snow and ice so that it can be found if subsequent snowfall or drifting covers the spill.	T-1
(v) Exclusion Procedures	The ACS <i>Technical Manual</i> is consulted to determine shoreline sensitivities and priority protection sites. No priority protection sites lie in the spill trajectory. The area is monitored for birds and mammals that may be at risk from the spill.	ACS Atlas Map 103 W-6
(vi) Spill Containment and Control Actions and (vii) Spill Recovery Procedures	<p>Freeze-Up:</p> <ul style="list-style-type: none"> • A staging area and field command post are set up at the CPF in the parking area located east of Building 201. • After the decontamination area is set up, a snow berm is constructed around the perimeter of the spilled diesel on the pad. Areas are shored continually and as necessary so that as much of the spill as possible is contained on the pad. • On the pad, a loader mixes snow with remaining free oil and places the mixture into a lined containment area. A vacuum truck removes remaining pools of oil from the pad. • After liquids are removed, grid sampling indicates the depth of diesel penetration in the pad. A loader and a backhoe remove up to 360 cubic yards of oiled gravel. A loader transports the gravel to a stockpile in a temporary lined and diked containment area located south of Central Storage. Gravel is stored for later handling. • Diesel is retained by snow on the tundra and frozen ponds and spreads to a maximum depth of 6 inches. A loader mechanically removes heavily oiled snow from the tundra to a depth of 6 inches. A bobcat is used for hard-to-reach areas. Lightly oiled snow is mixed with heavily oiled snow and removed by a loader or bobcat. • Approximately 1,130 cubic yards of oiled snow is removed and transferred to a temporary lined storage pit constructed on the pad. The storage pit is 90 feet by 90 feet by 3 feet, with an additional 2 feet of freeboard. The pit is located south of Central Storage. Snow is piled in the pit to form a peak. <p>Winter:</p> <ul style="list-style-type: none"> • When the pond ice is thick enough for safe operations, a bobcat with trimmer attachment mechanically removes diesel-contaminated snow on the ponds to a depth of 6 inches. • Diesel contained by broken ice on the northeast shore of the ponds remains embedded in the ice as the ponds completely freeze. The trimmer then removes the diesel-contaminated ice. Oiled ice is transported to temporary lined storage pits constructed on the pad. 	L-2 C-1 R-3, R-6(2) R-26 R-3 L-7, R-3 R-5
(viii) Lightering Procedures	Not applicable	Not applicable

**TABLE 1-31 (CONTINUED)
DIESEL TANK RUPTURE DURING FREEZE-UP
RESPONSE STRATEGY**

ADEC REQUIREMENT	RESPONSE STRATEGY	ACS TECH. MANUAL TACTIC
(ix) Transfer and Storage of Recovered Oil/Water; Volume-Estimating Procedure	<ul style="list-style-type: none"> • Recovered diesel and water are hauled by vacuum truck across the pad to the facility's liquid process tanks for processing. Processed liquids are manifested. Oily sorbents are hauled by ATV on plywood paths to the pad. • Oiled snow and ice are transferred by loaders and stockpiled in interim storage on the pad until break-up. When the snow begins to melt, vacuum trucks recover and transport oily liquids to the processing facility. 	<p align="center">D-1</p> <p align="center">D-2, D-1</p>
(x) Plans, Procedures, and Locations for Temporary Storage and Disposal	<p>Temporary storage facilities are established on the pad for contaminated snow, ice, and oily wastes.</p> <ul style="list-style-type: none"> • Oily liquids are recycled and manifested. • Contaminated snow is hauled to the storage cell for melting and processing. The oiled snow is allowed to melt in the spring. Liquids are pumped off with vacuum trucks as they become available and transported to the processing facility. • Non-liquid oily wastes are classified and disposed of according to classification. • Non-oily wastes are classified and disposed of accordingly. • Oiled gravel is excavated and stockpiled under a treatment plan approved by ADEC. 	<p align="center">D-1</p> <p align="center">D-5</p> <p align="center">D-2</p> <p align="center">D-3</p> <p align="center">D-4</p>
(xi) Wildlife Protection Plan	<ul style="list-style-type: none"> • The wildlife protection strategy is implemented. Monitors for Polar bears are assigned. • A bird-hazing team deploys passive hazing devices at the pond beginning on the first shift. • The Wildlife Stabilization Center is made operational in Deadhorse. No oiled animals are encountered. 	<p align="center">W-1</p> <p align="center">W-2B</p> <p align="center">W-5</p>
(xii) Shoreline and Tundra Cleanup	<ul style="list-style-type: none"> • The shoreline is cleaned to the satisfaction of ADEC in the shortest possible time with teams of shoreline cleanup crews and equipment. Oily waste is hauled to a controlled and lined collection area on the pad, south of Central Storage. • Heavier pockets of stranded diesel are collected manually. • The ponds are monitored during and after break-up. 	<p align="center">SH-1</p> <p align="center">SH-5</p>

**TABLE 1-32
DIESEL TANK RUPTURE DURING FREEZE-UP
OIL RECOVERY CAPACITY**

A	B	C	D	E	F	G
SPILL RECOVERY TACTIC	NUMBER OF SYSTEMS	RECOVERY SYSTEM	DERATED OIL RECOVERY RATE (boph)	MOBILIZATION, TRANSIT, AND DEPLOYMENT TIME TO SITE (hours)	OPERATING TIME (hours in a 24-hour shift)	DAILY DERATED OIL RECOVERY CAPACITY (bpd) (B x D x F)
R-6	2	Vacuum Truck with Manta Ray Skimmer	27	1.5 ¹	16 ²	864
R-3, R-26	1	Front End Loader	20	1.5 ¹	20	400

¹ Time values taken from the ACS *Technical Manual*.

² Trucks operate 20 hours per day, but only 16 hours per day are spent in recovery operations and 4 hours per day are needed for offloading.

**TABLE 1-33
DIESEL TANK RUPTURE DURING FREEZE-UP
LIQUID HANDLING CAPABILITY**

A	B	H	I	J	K	L	M	N	O	P
SPILL RECOVERY TACTIC	NUMBER OF STORAGE SYSTEMS	STORAGE CAPACITY DESCRIPTION	STORAGE CAPACITY (bbl)	OIL/EMULSION AVAILABLE (bph)	TIME ON LOCATION BEFORE OFFLOAD NEEDED (hours) (I/J)	OFFLOADING MECHANISM	OFF-LOADING RATE (bph)	TRANSIT TIME – BOTH WAYS (hours)	OFF-LOADING TIME (hours) (I/M)	OFFLOAD AND TRANSIT TIME (hours) (N+O)
R-6	2	Vacuum Truck	100 each	27 ¹	3.7 ²	Vacuum truck	200	0.5	0.5	1

¹ The total volume of diesel and free water available for storage is the recovered volume of diesel using a Manta Ray. Emulsification is not a factor.

² Time before offload is needed assumes a maximum derated recovery rate of 27 bph for a Manta Ray skimmer.

**TABLE 1-34
DIESEL TANK RUPTURE DURING FREEZE-UP
MAJOR EQUIPMENT FOR RECOVERY AND TRANSFER**

TACTIC	NO. TACTICAL UNITS	EQUIPMENT PER TACTICAL UNIT	TOTAL QUANTITY
C-1	1	Front-end Loader	1
R-3	1	Front-end Loader (shared with C-1)	1
		Bobcat	1
R-6	2	Vacuum Truck	2
		Manta Ray Skimmer Head	2
R-26	1	Front-end Loader	1
		Grader	1
R-5	1	Bobcat	1
		Trimmer	1
		Front-end Loader (shared with R-26)	1

**TABLE 1-35
DIESEL TANK RUPTURE DURING FREEZE-UP
STAFFING TO OPERATE OIL RECOVERY AND TRANSFER EQUIPMENT**

LABOR CATEGORY	TACTIC	NO. TACTICAL UNITS	NO. STAFF PER UNIT	NO. STAFF PER SHIFT ¹
Team Lead	R-3	1	1	1
	R-6	2	1	2
	R-5	1	1	1
Skilled Technician	R-3	1	1	1
	R-6	2	1	2
	R-5	1	2	2
	T-1	1	2	2
Equipment Operator	C-1	1	1	1
	R-3	1	2	2
	R-6	2	1	2
	R-26	1	2	2
	R-5	1	2	2
Total Technicians ²	-	-	-	7

¹The staffing schedule is shown in the column for number of staff per period. Number of staff recovering oil becomes zero after Hour 72.

²The total tallies the Technicians; Team Leads are Skilled Technicians.

FIGURE 1-12 DIESEL TANK RUPTURE DURING FREEZE-UP VICINITY MAP

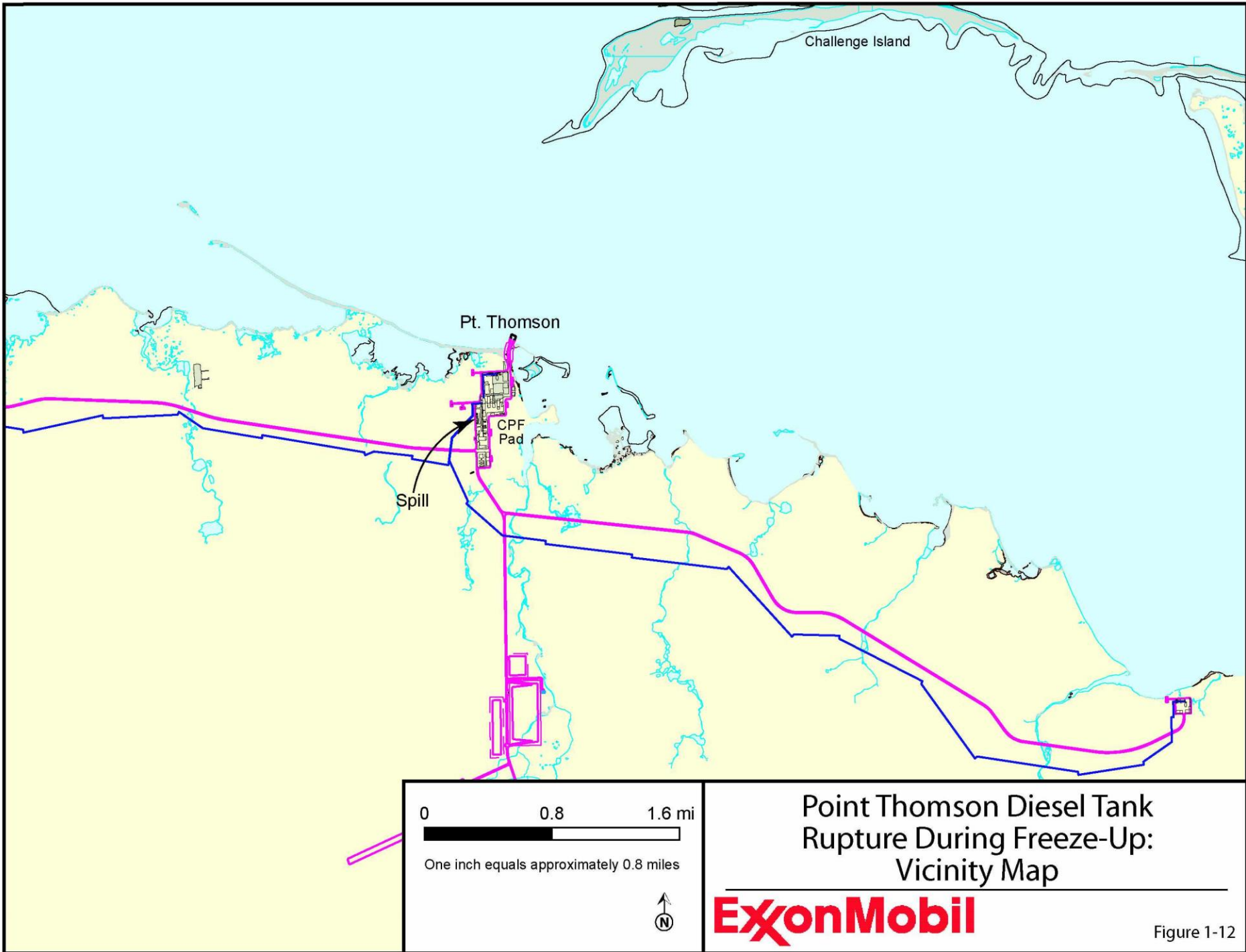
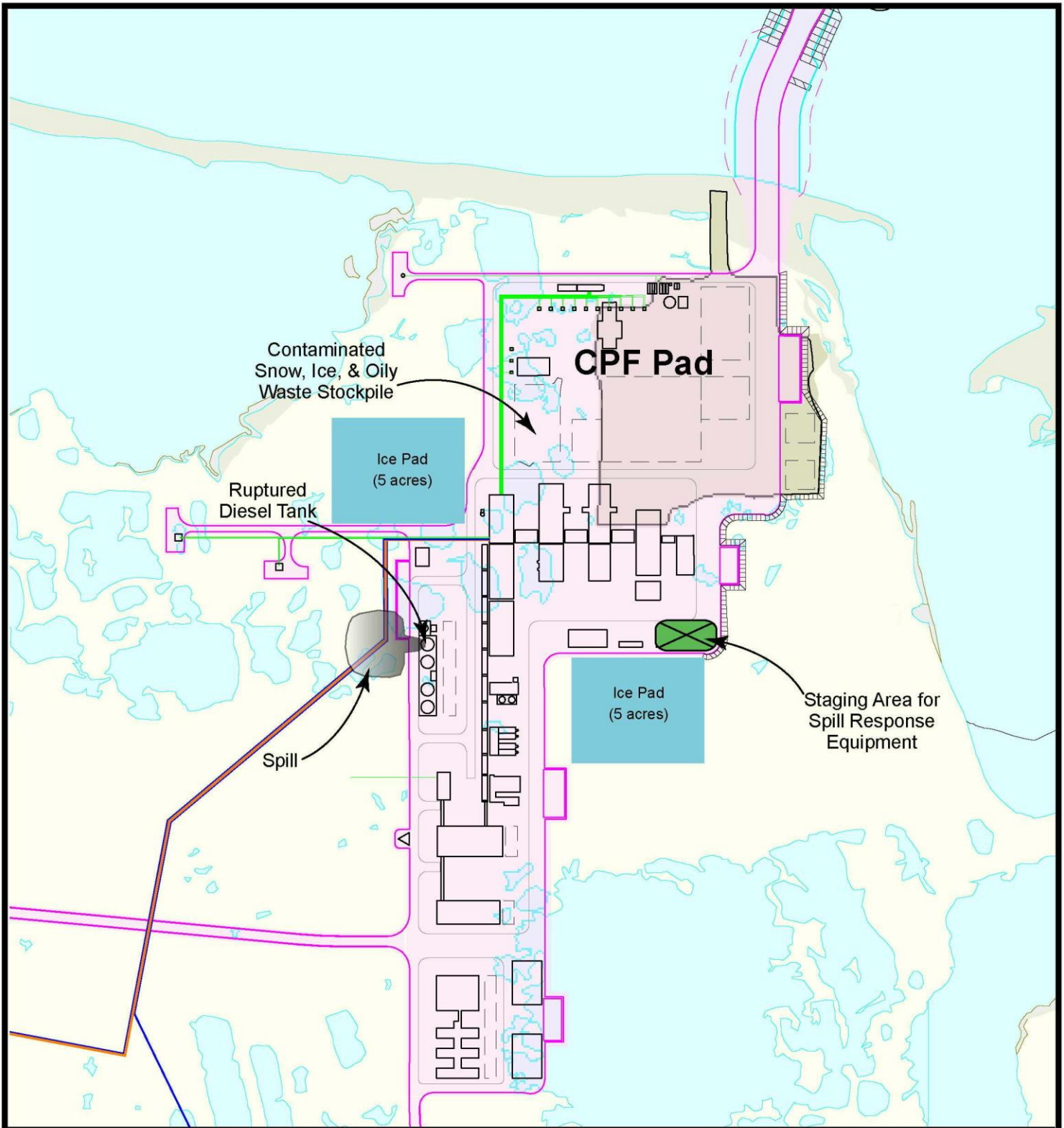

FIGURE 1-13 DIESEL TANK RUPTURE DURING FREEZE-UP



0 450 900 ft.
 one inch equals approximately 450 feet



Point Thomson Diesel Tank Rupture During Freeze-Up

ExxonMobil

Figure 1-13

SCENARIO 5

POINT THOMSON WELL BLOWOUT DURING WINTER

THIS PAGE INTENTIONALLY LEFT BLANK

**TABLE 1-36
POINT THOMSON BLOWOUT DURING WINTER
SCENARIO CONDITIONS**

INITIAL CONDITIONS	
Spill Location	Point Thomson CWP
Spill Time	March 1-15
Source of Spill	Uncontrolled well blowout through the casing and drill pipe annulus, open to the atmosphere
Type of Spill	Well blowout
Quantity of Spilled Oil	<p>RPS Volumes:</p> <p>Day 1, Hours 0 to 2 (prior to well ignition): 517 bbl</p> <p>Sum of Day 1, Hours 2-24 Volume and Days 2 through 15 Volume (after well ignition): 206 bbl</p> <p>Total 15-day RPS Volume: 723 bbl</p>
Oil Type	Condensate
Wind Speed	56 knots. This is the highest wind speed recorded for any 2-hour time period of wind data from the meteorological station located west of Point Thomson.
Wind Direction	From east (85 degrees) during first 2 hours on Day 1 and variable during remainder of Day 1. Variable winds from the east on Days 2 through 15.
Current	Lagoon frozen, no open water
Air Temperature	-15 °F
Visibility	Unrestricted
Surface	<p>The winter period is characterized by stable landfast (also called shorefast) ice. The sheet ice grows to an average maximum thickness of 6 to 7 feet by the end of May. This means that ice in the shallow waters throughout most of the lagoon between Point Thomson and Brownlow Point becomes frozen to the seafloor at the end of the ice growth cycle (Vaudrey, 1985c).</p> <p>Once the nearshore ice is established and stable, the seaward fast ice edge remains close to the 60-foot water depth in most years. The average water depths at the fast ice edge are approximately 45 to 50 feet from December to March. Off Flaxman Island, these water depths correspond to distances of 7 to 8 miles from shore in January to March (Dickins, 1985 unpublished).</p>
Trajectory	<p>The condensate is modeled to be ejected into the air, with a gas-to-condensate ratio of approximately 17,250 scf/bbl and gas flow rate of 465 mmscf/d. The well is located on the CWP.</p> <p>Prior to Blowout Ignition:</p> <p>The wind blows the condensate to the west of the well in the 2 hours prior to ignition, based on the most frequently measured wind direction, and the highest 2-hour velocity data from a meteorological station located west of Point Thomson. The deposition footprint is predicted by the SCIPUFF dispersion model using dodecane as a surrogate for condensate to simulate the well blowout scenario for the first 2 hours.</p> <p>On Day 1, during the first 2 hours of the blowout, condensate from the well impacts surfaces on the production pad and the surrounding area at the rate of 259 bph. 517 bbl of condensate is distributed over a lenticular area of 6.5 square miles or 4,127 acres [approximately 9.3 miles long x 0.9 mile wide at the broadest point] west of the well. Of this dispersion, 94.2 percent (487 bbl) falls within 9.3 miles of the well, at which distance the condensate thickness is less than 0.001 millimeter (mm) (0.00004 inch). Approximately 5.8 percent (30 bbl) of condensate that moves westward as fine airborne particulates does not precipitate or settle onto the ground surface. Figure 1-14 illustrates the condensate dispersion at Hour 2 of the well blowout.</p> <p>Condensate falling to the pad accumulates in depressions. Condensate falling onto the frozen, snow-covered surfaces accumulates at a thickness ranging from 10 mm (0.4 inch) next to the well to 0.001 mm (0.00004 inch) at a distance of 9.3 miles. Approximately 55 percent (284 bbl) of the condensate falls in a 0.17 square mile (109 acres) lens extending approximately 1 mile west of the well. The original condensate thickness in this area averages 1 mm (0.04 inch). Under the 56-knot wind, the condensate mixed with snow blows into windrows having an average condensate thickness of 2 mm (0.08 inch) on half of the area (54.5 acres).</p>

TABLE 1-36 (CONTINUED)
POINT THOMSON BLOWOUT DURING WINTER
SCENARIO CONDITIONS

INITIAL CONDITIONS	
Trajectory (continued)	<p>From 1 mile to 3 miles west of the well, an additional 26 percent (134 bbl) of the condensate falls in a 1-square mile (640 acres) lens. The average condensate thickness in this lens is 0.05 mm (0.002 inch). Under the 56 knot wind, the condensate mixed with snow blows into windrows having an average condensate thickness of 0.1 mm (0.004 inch) on half of the area (320 acres).</p> <p>The remaining condensate that precipitates or settles onto the ground surface is 12.9 percent (67 bbl) of the total released from the blowout in the first 2 hours. This condensate falls in a 5.25 square mile (3,360 acres) lens. The average condensate thickness upon deposition is 0.005 mm (0.002 inch). Under the 56-knot wind, the condensate mixed with snow blows into windrows having an average condensate thickness of 0.01 mm (0.0004 inch) on half of the area (1,680 acres).</p> <p>After Blowout Ignition:</p> <p>90 percent of the condensate is lost to combustion when the aerial plume ignites on Day 1, Hour 2. The scenario assumes that 1 percent of the unburned condensate is liquid, with the remaining 99 percent as soot.</p> <p>The 1 percent of the unburned condensate which falls to the ground surface (206 bbl) is distributed variably in every direction around the well. The 206 bbl is dispersed so thinly that it is infeasible to detect and pick up by cleanup task forces.</p> <p>A diagram is not provided for the blowout scenario for the period after the well is ignited. It is assumed a volume of 517 bbl of condensate falls out to the west during the 2 hours prior to ignition and 206 bbl of condensate are distributed in the area surrounding the well during the 14 days and 22 hours after the well is ignited, for a total of 723 bbl from the well blowout.</p>

**TABLE 1-37
POINT THOMSON BLOWOUT DURING WINTER
RESPONSE STRATEGY**

ADEC REQUIREMENT	RESPONSE STRATEGY	ACS TECHNICAL MANUAL TACTIC
(i) Stopping Discharge at Source	<p>The Drilling Supervisor notifies the Drilling Operations Superintendent. The Drilling Supervisor takes the role of the Initial On-Scene Commander, until relieved by the Drilling Operations Superintendent. The Drilling Supervisor makes the decision to ignite the well at Hour 2.</p> <p>Well control experts are called out from Houston, Texas, arriving in 24 hours.</p> <p>The appropriate agency notifications are made. The Incident Management Team is activated.</p> <p>The scenario assumes that the blowout is voluntarily ignited at the rig floor on Day 1, Hour 2. The effect of the ignition on operations is to (1) increase safety by removing toxic and flammable gases, and (2) decrease pollution of the frozen land and water surface.</p>	<p>A-1 A-2 Vol. 3 IMS</p> <p>L-5 L-9</p> <p>See Plan Section 1.6.3</p>
(ii) Preventing or Controlling Fire Hazards	<p>The Site Safety Officer, Incident Commander, and Company Representative set up access zones and routes and fire-fighting operations to protect assets and workers. The Site Safety Officer determines personal protective equipment (PPE) requirements and provides hot and warm zone access information. Access to the spill site is carefully controlled and the scene is secured by Security. Monitoring protocol is established by the Site Safety Officer at work areas for personnel protection. The monitoring protocol establishes safety zones according to applicable OSHA and fire hazard standards.</p> <p>Containment and recovery operations are allowed without respiratory protection in areas where safety criteria are met. Recovery operations and oil field operations and traffic are disallowed downwind of the blowout well in areas where cleanup workers may become exposed to flash fire hazard or oil particulate matter at concentrations in excess of permissible exposure limits.</p>	<p>S-1 through S-6</p>
(iii) Well Control Plan	<p>Over the course of 15 days, a new capping stack is installed. The oil from the well burns without interruption until it is diverted with the capping stack as part of the kill step.</p> <p>See Section 1.6.3 for a description of well control.</p>	<p>Plan Section 1.6.3</p>
(iv) Surveillance and Tracking of Oil; Forecasting Shoreline Contact Points	<p>The extent of oil on the snow is delineated beginning on Day 1 so that it can be found if subsequent snowfall or blowing snow covers the spill. Delineation team will use Tucker snowcat and snow machines for ground transportation.</p>	<p>T-1 T-2</p>
(v) Exclusion Procedures; Protection of Sensitive Resources	<p>The ACS <i>Technical Manual Map Atlas</i>, Sheet 103, is consulted to determine shoreline sensitivities and priority protection sites. No priority protection sites lie in the spill trajectory. The area is monitored for birds and mammals that may be at risk from the spill.</p>	<p>Map Sheet #103 L-2</p>
(vi) Spill Containment and Control Actions	<p>Day 1:</p> <p>When it is determined safe to do so, snow berms are constructed upwind of the blowout to provide initial containment. Containment berms are constructed to the north, east, and south of the pad in an effort to contain condensate on the pad.</p> <p>Vacuum trucks pump condensate accumulating within the bermed areas.</p> <p>A temporary containment area is constructed. One 50-foot x 200-foot x 2-foot lined storage pit is excavated in the CPF pad east of the Construction Camp parking area. The pits are bermed with the excavated gravel to a height of 3 feet. The pits contain snow piled to a height of 15 feet. This storage area is used for staging contaminated snow.</p> <p>A staging area is constructed in the Construction Camp and the Construction Camp parking area.</p>	<p>C-1</p> <p>R-6</p>

**TABLE 1-37 (CONTINUED)
POINT THOMSON BLOWOUT DURING WINTER
RESPONSE STRATEGY**

ADEC REQUIREMENT	RESPONSE STRATEGY	ACS TECHNICAL MANUAL TACTIC
(vi) Spill Containment and Control Actions (Continued)	<p>Days 2 Through 15:</p> <p>After well ignition at Hour 2, the wind shifts from a predominantly easterly wind to a variable wind. The total volume of condensate falling to the frozen ground and ice surface is reduced to less than 14 bbl per day. This condensate falls to the ground and is absorbed by snow and ice. No additional containment is required.</p>	L-2
(vii) Spill Recovery Procedures	<p>Day 1:</p> <p>Task Force 1: On the pad, a loader mixes snow with remaining free condensate where it is safe and places the mixture into a lined containment area. Vacuum trucks remove any remaining pools of condensate from the pad.</p> <p>Days 2 Through 15:</p> <p>Beginning on Day 2, an ice road is constructed extending 1 mile west of the well. The ice road is constructed to provide equipment access to the area most heavily oiled. The road is constructed using a grader from Point Thomson. The water truck is mobilized from Prudhoe Bay by Rolligon. Assuming a 1-day mobilization to Point Thomson, a 1-mile ice road would be completed by the end of Day 3.</p> <p>Task Forces focus on recovering condensate that previously fell to the west of the well during the first 2 hours of Day 1. Recovery of contaminated snow covering river and lake environments is addressed first.</p> <ul style="list-style-type: none"> • Task Force 1 (TF-1) recovers oiled snow from safe areas extending out approximately 1 mile. TF-2 mobilizes on Day 3 after completion of the ice road. Two dump trucks are mobilized to Point Thomson from Prudhoe Bay by Rolligon. The trucks are deployed on Day 1, Hour 2, and arrive at Point Thomson on Day 3. The objective is to recover the 284 bbl of condensate deposited on approximately 109 acres. • Task Force 2 (TF-2) manually recovers lightly misted snow extending from approximately 1 mile west of the well to 3 miles west of the well. TF-2 consists of two recovery teams that transport recovered snow by snow machine to the constructed ice road where the snow is loaded into dump trucks. The objective of TF-2 is to manually recover, as practicable, the 134 bbl of lightly misted condensate from approximately 640 acres. An additional 67 bbl of condensate was deposited in a lens extending from 3 miles to 9.3 miles west of the well. The Unified Command determines it is not practical to recover condensate beyond 3 miles without damage to the ground surface. 	<p>R-3</p> <p>L-1</p> <p>R-6 (2)</p> <p>R-2, R-1</p> <p>R-1A (2)</p>
(viii) Lightering Procedures	Not applicable	Not applicable
(ix) Transfer and Storage of Recovered Oil/Water; Volume-Estimating Procedure	<p>Recovered oil is hauled by vacuum truck across the pad to the facility's liquid process tanks for processing. Processed liquids are manifested.</p> <p>Oiled snow and ice are transferred by loaders and dump trucks to the lined storage area until break-up. When the snow begins to melt, the oily liquids will be transferred to the processing facility.</p> <p>A Waste Team member at each receiving facility logs the quantity of oil estimated with a Coliwasa tube in the vacuum truck tanks and the quantity of oiled snow and ice dumped into lined pits. The oil volume and water cut in vacuum trucks hauling oil separated from melting snow can be estimated with a Coliwasa tube.</p>	<p>D-1</p> <p>R-6</p> <p>D-2</p> <p>D-5</p>

TABLE 1-37 (CONTINUED)
POINT THOMSON BLOWOUT DURING WINTER
RESPONSE STRATEGY

ADEC REQUIREMENT	RESPONSE STRATEGY	ACS TECHNICAL MANUAL TACTIC
(x) Plans, Procedures, and Locations for Temporary Storage and Disposal	<p>Temporary storage facilities are established on the pad, for contaminated snow, ice, and oily wastes.</p> <ul style="list-style-type: none"> • Oily liquids are injected into the disposal well. • Contaminated snow is hauled to the storage cell for melting and processing. The oiled snow is allowed to melt in the spring. Liquids are pumped off and transported to the processing facility. • Non-liquid oily wastes are classified and disposed of according to classification. • Non-oily wastes are classified and disposed of accordingly. • Oiled gravel is excavated and treated under a contaminated soil and stockpiled under a treatment plan approved by ADEC. 	<p>D-1</p> <p>D-5</p> <p>D-2</p> <p>D-3</p> <p>D-4</p>
(xi) Wildlife Protection Plan	<p>The wildlife protection strategy is implemented. Polar bear monitors are assigned.</p> <p>A bird hazing team deploys passive hazing devices beginning on the first shift.</p> <p>The Wildlife Stabilization Center is made operational in Deadhorse. No oiled animals are encountered.</p>	<p>W-1</p> <p>W-2B</p> <p>W-5</p>
(xii) Shoreline Cleanup Plan	<p>A shoreline cleanup plan is submitted to Unified Command before break-up in case oiled shorelines are discovered after break-up. At break-up, the Shoreline Cleanup Assessment Team (SCAT) monitors the tundra and adjacent shorelines for oiling according to the plan and find none. Ponds are monitored during and after break-up as a non-emergency project.</p>	<p>SH-1</p> <p>SH-5</p> <p>See p. 3-28</p>

**TABLE 1-38
POINT THOMSON BLOWOUT DURING WINTER
OIL RECOVERY CAPACITY**

A	B	C	D	E	F	G
SPILL RECOVERY TACTIC	NUMBER OF SYSTEMS	RECOVERY SYSTEM	DERATED OIL RECOVERY RATE (boph)	MOBILIZATION, TRANSIT, AND DEPLOYMENT TIME TO SITE (hours) ^{1,2}	OPERATING TIME (hours in a 24-hour shift)	DAILY DERATED OIL RECOVERY CAPACITY (bpd) B x D x F
TF-1: R-2	1	Manual Recovery	0.9	48	20	18
TF-1: R-1	1	Loader, 2 Dump Trucks	39	48	20	780
TF-2: R-2	2	Manual Recovery	0.9	48	20	36

¹ TF-1 and TF-2 recovery begins when safe working zone is established on Day 2, and rolling stock arrives from Prudhoe Bay.

² Recovery rates are calculated with ACS *Technical Manual* planning capacities, as follows:

- TF-1 R-1 is limited by the dump trucks. Using two 20-yard dumps and a maximum one-way travel distance of 1 mile and the planning capacity of 0.3 bbl of oil per cubic yard of snow, the daily recovery rate is 780 bbl. Tactic R-2 uses one team of six laborers generating 10 cubic yards per shift, 2 shifts per day. Assuming 0.9 bbl of oil per cubic yard, the recovery rate is 18 bbl per day.
- TF-2 uses Tactic R-2 with two crews. Assuming 18 bopd per crew, TF-2 recovers 36 bopd.

TABLE 1-39
POINT THOMSON BLOWOUT DURING WINTER
MAJOR EQUIPMENT EQUIVALENTS TO MEET THE RESPONSE PLANNING
STANDARD

RECOVERY TACTIC	NO. TACTICAL UNITS	EQUIPMENT PER TACTICAL UNIT	TOTAL QUANTITY
R-1	1	1 each Front Loader	1
		2 each 20-yard Dump	2
R-1A	2	3 each Snow Machine (shared with R-2)	6
		1 each Snow Blower	2
R-2	1	3 each Snow Machine (shared with R-1A)	3
		1 each Front Loader	1
R-3	1	1 each Front loader	1

TABLE 1-40
POINT THOMSON BLOWOUT DURING WINTER
NUMBER OF STAFF PER SHIFT TO OPERATE OIL RECOVERY AND TRANSFER
EQUIPMENT

LABOR CATEGORY	TASK FORCE AND TACTIC	NO. TACTICAL UNITS	NO. STAFF PER TACTICAL UNIT	NUMBER OF STAFF PER SHIFT		
				DAY 1	DAYS 2 AND 3	DAYS 3 THROUGH 15
Team Lead	TF1: R-3	2	1	1		
	TF1: R-1, R-2	2	1		1	1
	TF2: R-1A	2	1			1
Skilled Technician	TF1: R-3	2	1	1		
	TF1: R-1, R-2	2	1		5	5
	TF2: R-1A	2	1			2
General Technician	TF1: R-3	2	2	4		
	TF1: R-1, R-2	2	1		20	20
	TF2: R-1A	2	1			6
Total Technicians				5	25	33

Note: Totals exclude team leads because they are tallied as skilled technicians. The staffing schedule is shown in the column for number of staff per shift. Number of staff per shift decreases to zero after the day represented in the last column.

THIS PAGE INTENTIONALLY LEFT BLANK

**FIGURE 1-14 BLOWOUT DURING WINTER: EXTENT OF BLOWOUT PLUME PRIOR TO
IGNITION**

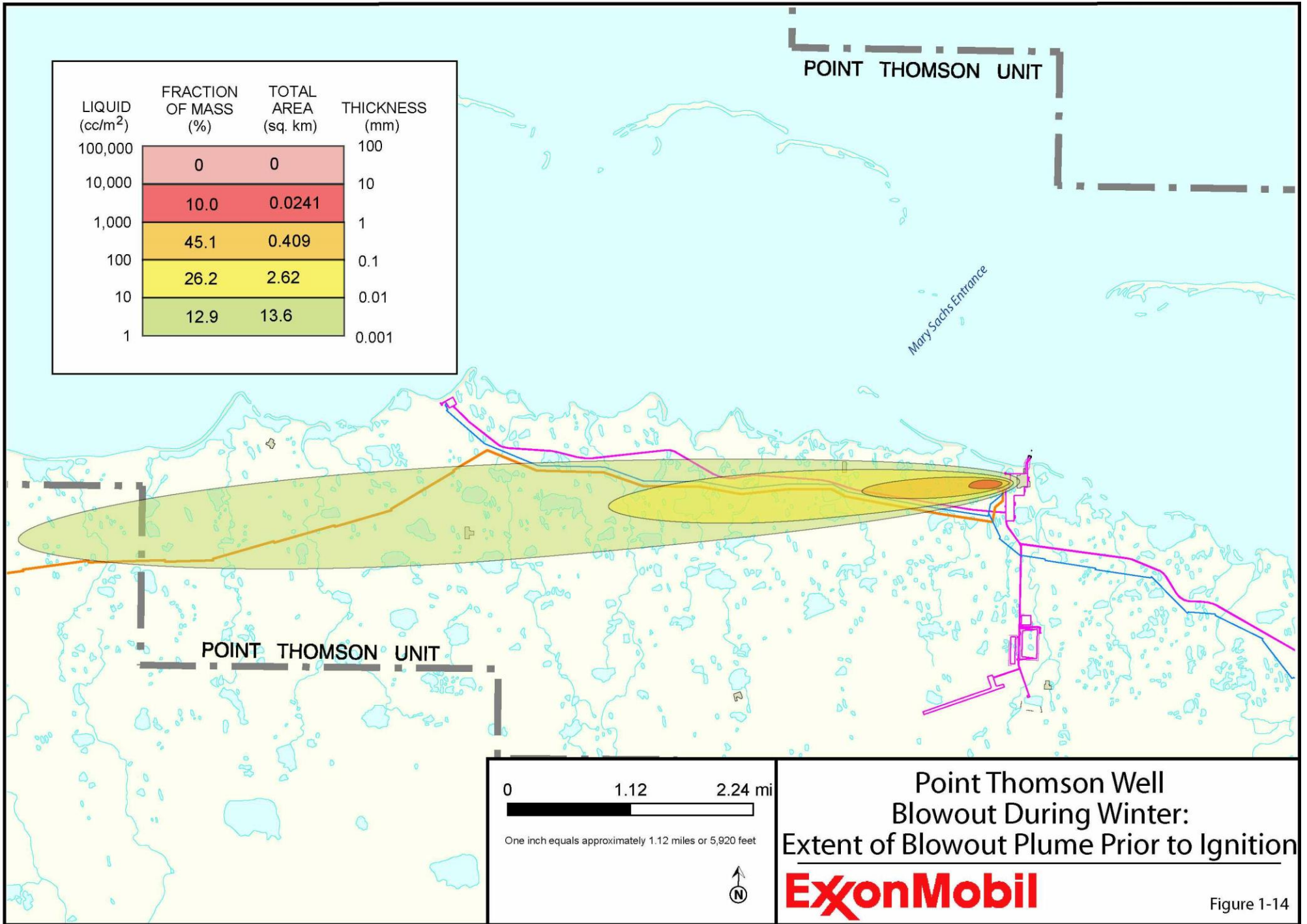
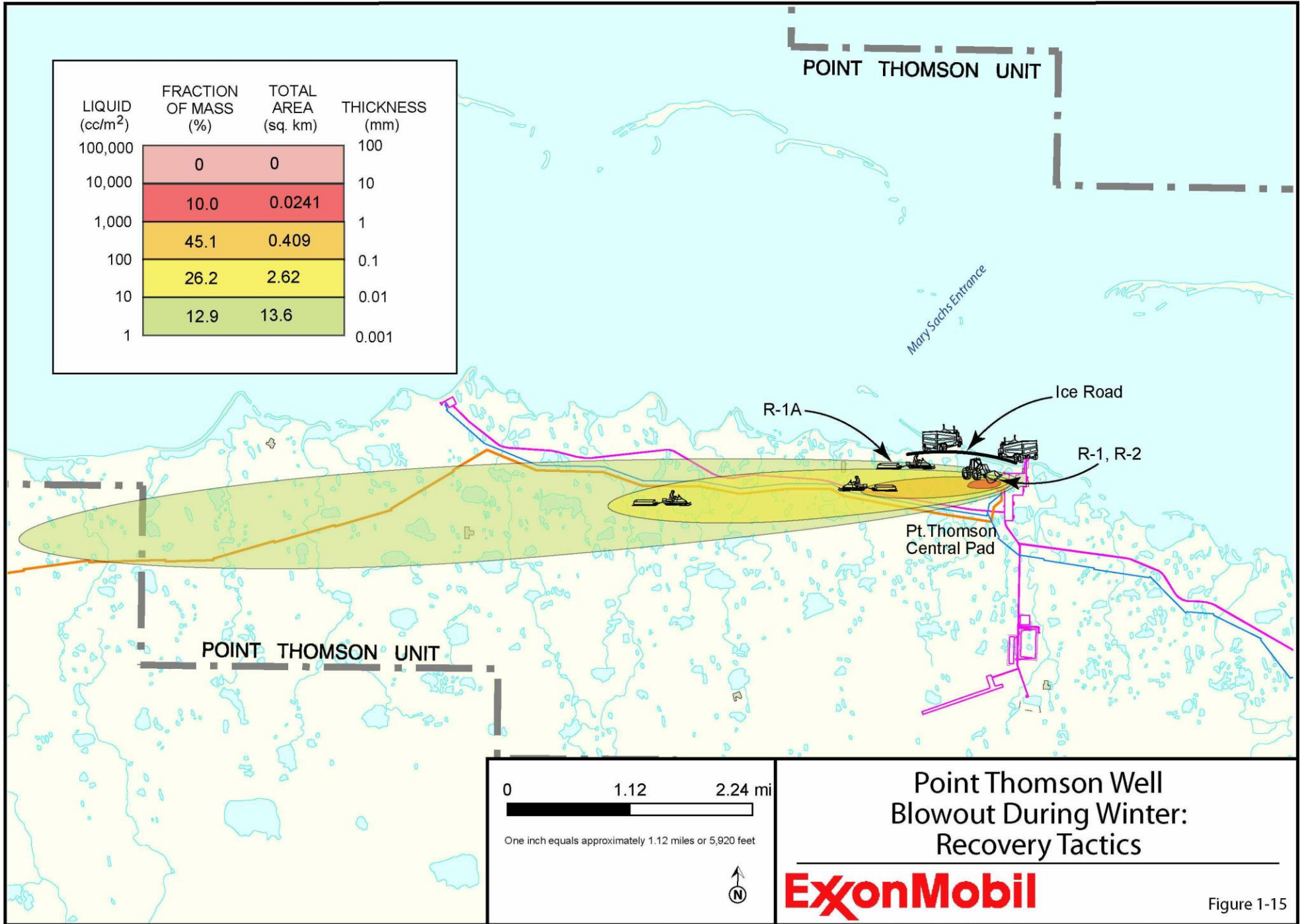

FIGURE 1-15 BLOWOUT DURING WINTER: RECOVERY TACTICS



SCENARIO 6

POINT THOMSON WELL BLOWOUT DURING SUMMER

THIS PAGE INTENTIONALLY LEFT BLANK

**TABLE 1-41
POINT THOMSON CONDENSATE BLOWOUT DURING SUMMER
SCENARIO CONDITIONS**

INITIAL CONDITIONS	
Spill Location	Point Thomson CWP
Spill Time	August 1-15
Source of Spill	Uncontrolled well blowout through the casing and drill pipe annulus, open to the atmosphere
Type of Spill	Well Blowout
Quantity of Spilled Oil	RPS Volumes: Day 1, Hours 0 to 2 (prior to well ignition): 517 bbl Sum of Day 1, Hours 2-24 Volume and Days 2 through 15 Volume (after well ignition): 206 bbl Total 15-day RPS Volume: 723 bbl
Oil Type	Condensate
Wind Speed	18 knots
Wind Direction	From southwest during first 2 hours on Day 1 and variable during remainder of Day 1. Variable on Days 2 through 15.
Current	Marine surface water flows 0.6 knots at 3 percent of wind speed.
Air Temperature	40°F
Visibility	Unrestricted
Trajectory	<p>The condensate is modeled to be ejected into the air, with a gas-to-condensate ratio of approximately 17,250 scf/bbl and gas flow rate of 465 mmscf/d. The well is located on the CWP.</p> <p>Prior to Blowout Ignition:</p> <p>The wind blows the condensate to the northeast of the well in the 2 hours prior to ignition, based on the most frequently measured wind direction and velocity data from a meteorological station located west of Point Thomson. The deposition footprint is predicted by the SCIPUFF dispersion model using dodecane as a surrogate for condensate to simulate the well blowout scenario for the first 2 hours.</p> <p>On Day 1, during the first 2 hours of the blowout, condensate from the well impacts surfaces on the production pad and the surrounding area at the rate of 259 bph. A total of 517 bbl of condensate is distributed over a lenticular area of 3.6 square miles or 2,304 [approximately 5.3 miles long x 0.68 mile wide at the broadest point] northeast of the well. Of this dispersion, 85.5 percent (442 bbl) falls within 5.3 miles of the well. On the sea at that distance, the condensate under the plume is less than 0.001 mm thick (0.00004 inch) and spreads thinner as it is carried by currents. Approximately 14.5 percent (75 bbl) of condensate that moves over the sea as fine airborne particulates disperses and does not settle or enter water.</p> <p>Condensate thickness and deposition were predicted using the SCIPUFF model. Volumes of condensate fallout to the tundra and pad gravel were extrapolated from the model results. Figure 1-16 shows the deposition of the condensate on land and water at Hour 2.</p> <p>Condensate Deposition to Land:</p> <p>Volume retained in pad gravel = 44 bbl Volume retained in tundra on shore = 47 bbl Volume retained in tundra on Mary Sachs Island = 5 bbl</p> <p>Condensate Deposition to Open Water:</p> <p>Area A is 1 to 10 mm thick, and covers approximately 0.0468 square kilometer (0.02 square mile). Approximately 50 percent of the condensate in Area A falls to open water; thus the volume of condensate offshore in Area A is 84 bbl.</p> <p>Area B is 0.1 to 1 mm thick and covers approximately 0.388 square kilometer (0.15 square mile). Approximately 97 percent of the condensate in Area B falls to open water; thus the volume of condensate offshore in Area B is 165 bbl.</p>

TABLE 1-41 (CONTINUED)
POINT THOMSON CONDENSATE BLOWOUT DURING SUMMER
SCENARIO CONDITIONS

INITIAL CONDITIONS	
Trajectory (continued)	<p>Area C is 0.01 to 0.1 mm thick and covers approximately 1.93 square kilometers (0.75 square mile). Approximately 92 percent of the condensate in Area C falls to open water; thus the volume of condensate offshore in Area C is 73 bbl.</p> <p>Area D is 0.001 to 0.01 mm thick and covers approximately 6.91 square kilometers (2.67 square miles). Approximately 96 percent of the condensate in Area D falls to open water; thus the volume of condensate offshore in Area D is 25 bbl.</p> <p>The condensate in Area D is not visible to the eye at deck level, nor is it recoverable by mechanical equipment due to its low viscosity. The Unified Command makes the decision to forego targeting condensate in this area based on these reasons</p> <p>After Blowout Ignition:</p> <p>90 percent of the condensate is lost to combustion when the aerial plume ignites on Day 1, Hour 2. The scenario assumes that 1 percent of the unburned condensate is liquid, with the remaining 99 percent as soot.</p> <p>The 1 percent, or 206 bbl, of the unburned condensate falls to the surface and is variably distributed in fine droplets in every direction around the well. The 206 bbl is so thinly distributed that it is infeasible to detect and pick up by cleanup task forces.</p> <p>A diagram is not provided for the blowout scenario for the period after the well is ignited. It is assumed a volume of 517 bbl of condensate falls out to the northeast during the 2 hours prior to ignition and 206 bbl of condensate are distributed in the area surrounding the well during the 14 days and 22 hours after the well is ignited, for a total of 723 bbl released during the well blowout.</p> <p>Over the course of the blowout, condensate spilled to open water is influenced by ocean currents and variable winds. These ocean currents and winds move the condensate toward the northern and southern shorelines of Mary Sachs Island, where unrecoverable condensate becomes stranded by the end of the blowout.</p>

TABLE 1-42
POINT THOMSON CONDENSATE BLOWOUT DURING SUMMER
RESPONSE STRATEGY

ADEC REQUIREMENT	RESPONSE STRATEGY	ACS TECHNICAL MANUAL TACTIC
(i) Stopping Discharge at Source	<p>The Drilling Supervisor notifies the Drilling Operations Superintendent. The Drilling Supervisor takes the role of the Initial On-scene Commander, until relieved by the Drilling Operations Superintendent. The Drilling Supervisor makes the decision to ignite the well at Hour 2.</p> <p>Well control experts are called out from Houston, Texas, arriving in 24 hours.</p> <p>The appropriate agency notifications are made. The IMT is activated.</p> <p>The scenario assumes that the blowout is voluntarily ignited at the rig floor on Day 1, Hour 2. The effect of the ignition on operations is to (1) increase safety by removing toxic and flammable gases, and (2) decrease pollution of the land and water surface.</p>	<p>A-1 A-2 Vol. 3 IMS</p> <p>L-5 L-9</p> <p>Plan Section 1.6.3</p>
(ii) Preventing or Controlling Fire Hazards	<p>The Site Safety Officer, Incident Commander, and Company Representative set up access zones and routes and fire-fighting operations to protect assets and workers. The Site Safety Officer determines PPE requirements and provides hot and warm zone access information. Access to the spill site is carefully controlled and the scene is secured by Security. Monitoring protocol is established by the Site Safety Officer at work areas for personnel protection. The monitoring protocol establishes safety zones according to applicable OSHA and fire hazard standards.</p> <p>Containment and recovery operations are allowed without respiratory protection in areas where safety criteria are met. Recovery operations and oil field operations and traffic are not allowed downwind of the blowout well in areas where cleanup workers may become exposed to flash fire hazard or oil particulate matter at concentrations in excess of permissible exposure limits.</p>	<p>S-1 through S-6</p>
(iii) Well Control Plan	<p>Over the course of 15 days, a new capping stack is installed. The oil from the well burns without interruption until it is diverted with the capping stack as part of the kill step.</p> <p>See Section 1.6.3 for a description of well control.</p>	<p>Plan Section 1.6.3</p>
(iv) Surveillance and Tracking of Oil; Forecasting Shoreline Contact Points	<p>Aerial observation from aircraft provides real-time tracking of the oil. A survey crew delineates the spill-affected area at on the gravel and tundra. NOAA is requested to provide trajectories based on wind speed and direction.</p>	<p>T-4 T-2 T-5</p>
(v) Exclusion Procedures; Protection of Sensitive Resources	<p>The ACS <i>Technical Manual Map Atlas</i>, Sheets 99, 100, and 103 are consulted to determine shoreline sensitivities and priority protection sites. No priority protection sites lie in the spill trajectory. The area is monitored for birds and mammals that may be at risk from the spill.</p>	<p>See Maps 99, 100, and 103 W-6</p>

TABLE 1-42 (CONTINUED)
POINT THOMSON CONDENSATE BLOWOUT DURING SUMMER
RESPONSE STRATEGY

ADEC REQUIREMENT	RESPONSE STRATEGY	ACS TECHNICAL MANUAL TACTIC
<p>(vi) Spill Containment and Control Actions</p> <p align="center">and</p> <p>(vii) Spill Recovery Procedures</p>	<p>A staging and decontamination area and field command post are set up at the CPF in the parking area located east of Building 201.</p> <p>CPF and Tundra Task Force: Day 1, Hour 8 to Day 3</p> <ul style="list-style-type: none"> After the decontamination area is set up, Team 1 places shoreseal boom and sorbent boom on the perimeter of the contaminated tundra to deflect and contain condensate. Team 1 also constructs gravel berms on the pad to ensure that the condensate remains trapped in the immediate areas and depressions. Team 2 cleans the tundra and gravel. Crews flush low-pressure water over the tundra, moving condensate down to collection areas where it is recovered with vacuum truck hoses and sorbent material. A vacuum truck collects from a position near the edge of the pad, with a Manta Ray skimmer head attached to the intake hose. The truck carries the oil to the disposal well for recycling, if safe to do so; otherwise, the truck will move to the staging area until safe to dispose in the disposal well. <p>Near Shore Recovery Task Force: Day 1, Hour 4 to Day 3</p> <p>Team 3 deploys offshore in the Beaufort Sea, 4 hours following well ignition. The team objective is to recover oil on water. The team works to recover condensate closest to the shorelines in Areas A and the parts of Areas B and C closest to the shore.</p> <p>Team 3 uses an airboat with closed tank and drum/brush combination skimmer and a boom-towing skiff to form a "J" boom configuration for recovery. The airboat unloads recovered fluids to a mini-barge towed by an Island Class vessel that then unloads to a vacuum truck at the Point Thomson dock. The team works close to the impacted shorelines of Mary Sachs Island.</p> <p>Open Water Recovery Task Force: Day 1, Hour 4 to Day 3</p> <p>Team 4 has the objective of recovering oil moving in windrows toward and past Mary Sachs Island on Day 1 and beyond.</p> <p>Team 4 uses the skimming vessel equipped with a MARCO Filter Belt skimmer and built in storage, along with a 20-foot airboat to form a "J" boom configuration for recovery. The skimming vessel unloads recovered fluids to a mini-barge towed by an Island Class vessel.</p>	<p align="center">L-2</p> <p align="center">C-4</p> <p align="center">R-4, R-6</p> <p align="center">R-17</p> <p align="center">R-17(2)</p>
<p>(viii) Lightering Procedures</p>	<p>No on-water lightering</p>	
<p>(ix) Transfer and Storage of Recovered Oil/Water; Volume-Estimating Procedure</p>	<p>Condensate recovered by the nearshore and open water task forces is pumped into mini-barges shuttled by an Island Class vessel. The Island Class vessel tows a loaded mini-barge from recovery vessels to Point Thomson dock for off-loading to a vacuum truck. The number and turnaround time of mini-barge transfers of stored liquid occurs at a greater rate than it is collected and, consequently, transfer does not constrain the on-water recovery rates.</p> <p>Ullage tape and Coliwasas tubes gauge liquid volumes and water in the vacuum trucks for waste manifests.</p>	<p align="center">R-22</p>

TABLE 1-42 (CONTINUED)
POINT THOMSON CONDENSATE BLOWOUT DURING SUMMER
RESPONSE STRATEGY

ADEC REQUIREMENT	RESPONSE STRATEGY	ACS TECHNICAL MANUAL TACTIC
(x) Plans, Procedures, and Locations for Temporary Storage and Disposal	<p>Temporary storage facilities in bermed, lined pits are established at CPF pad for oily wastes under a plan approved by the Unified Command and ADEC. Liquid and non-liquid wastes are characterized and disposed of accordingly. Recovery liquids are disposed of in the Class 1 disposal well.</p> <p>After liquids are removed, grid sampling indicates the depth of gravel penetration, and the contaminated gravel is excavated. The contaminated gravel is transported to a lined containment area south of Central Storage and stored for later handling.</p>	<p>D-1, D-2, D-3, D-4</p> <p>R-26</p>
(xi) Wildlife Protection Plan	<p>Resources at risk are primarily birds.</p> <ul style="list-style-type: none"> • The wildlife protection strategy is implemented on Day 1. • Wildlife hazing teams are deployed on oiled marine shorelines. • The Wildlife Stabilization Center is made operational at Deadhorse. • As oiled wildlife are identified, capture teams are deployed to the spill scene. • Captured birds are carried by wildlife response skiff to Point Thomson, where they are flown in fixed-wing aircraft to Deadhorse for treatment. 	<p>W-1</p> <p>W-2B</p> <p>W-5</p> <p>W-3</p>
(xii) Shoreline Cleanup Plan	<p>Shoreline Cleanup Task Force:</p> <p>Days 3-5</p> <ul style="list-style-type: none"> • Oil on the limited vegetation on Mary Sachs Island cannot be recovered without further damage to the environment. The Unified Command approves a plan for burning oiled vegetation on Mary Sachs Island. • Team 5 is deployed to Mary Sachs Island to begin burning the limited oily vegetation, where possible. Burning is conducted so that smoke and burning embers do not interfere with activities occurring downwind. • The shoreline is cleaned up to the satisfaction of ADEC in the shortest possible time with teams of shoreline cleanup crews and equipment. Oily waste is hauled to a controlled and lined collection area on the pad, south of Central Storage. • Heavier pockets of stranded condensate are collected manually. • Minor to moderately oiled areas near the pad are deluged to recover condensate. • On the tundra near the pad and on Mary Sachs Island, contaminated vegetation is left in place. Some is burned to reduce re-oiling of adjacent habitat. 	<p>SH-1</p> <p>SH-5</p> <p>SH-3</p> <p>B-1, B-2</p> <p>B-1, B-2</p>

**TABLE 1-43
POINT THOMSON CONDENSATE BLOWOUT DURING SUMMER
OIL RECOVERY CAPACITY**

A	B	C	D	E	F	G
SPILL RECOVERY TACTIC	NUMBER OF SYSTEMS	RECOVERY SYSTEM	DERATED RECOVERY RATE (bph)	MOBILIZATION, TRANSIT, AND DEPLOYMENT TIME TO SITE (hours)	OPERATING TIME (hours in a 24-hour shift)	MAXIMUM DAILY DERATED OIL RECOVERY CAPACITY (bpd) (B x D x F)
R-6	1	Vacuum Truck with Manta Ray skimmer	27	1.5	16 ¹	432
R-17 (nearshore)	1	Drum/Brush Combination Skimmer	28	4	20	560
R-17 (open water)	1	MARCO Filter Belt Skimmer	10	4	20	200

1. Truck operates 20 hours per day, but 16 hours per day are spent recovering and 4 hours per day are needed for offloading.

**TABLE 1-44
POINT THOMSON CONDENSATE BLOWOUT DURING SUMMER
LIQUID HANDLING CAPABILITY**

A	B	H	I	J	K	L	M	N	O	P
SPILL RECOVERY TACTIC	NUMBER OF STORAGE SYSTEMS	STORAGE CAPACITY DESCRIPTION	STORAGE CAPACITY (bbl)	OIL/EMULSION AVAILABLE (bph)	TIME ON LOCATION BEFORE OFFLOAD NEEDED (hours) (I/J)	OFFLOADING MECHANISM	OFF-LOADING RATE (bph)	ROUND TRIP TRANSIT TIME (hours)	OFF-LOADING TIME (hours)	OFFLOAD AND TRANSIT TIME (hours) (N+O)
R-17	2	Mini-barge	237 each	2 ¹	30	3-inch Trash pump ³	158	1.5 (average)	1.5	3
R-22	2	Fold-a-Tank	36 each	2 ¹	4.6	4-inch Trash pump ⁴	1,074	N/A ⁵	0.17	N/A ⁵
R-6	1	Vacuum Truck	100	1.6 ²	62.5	Vacuum Truck	200	0.5	0.5	1

1. Total recoverable oil to water equals 347 bbl. Oil/emulsion available is based on 20 working hours per day minus 4 hours to deploy, which equals 56 working hours occurring within a 72-hour period: (347 bbl ÷ 56 hr = 6.2 bph). Condensate does not form an emulsion with water; therefore there is no emulsification factor.
2. Total recoverable oil to tundra/pad equals 91 bbl. Oil/emulsion available is based on 20 working hours per day minus 4 hours to deploy, which equals 56 working hours occurring within a 72-hour period: (91 bbl ÷ 56 hr = 1.6 bph). Condensate does not form an emulsion with water; therefore there is no emulsification factor.
3. Recovered liquids are offloaded from mini-barges into Fold-a-Tanks at the Point Thomson dock using a 3-inch Trash pump.
4. Recovered liquids are offloaded from Fold-a-Tanks into a Vacuum Truck using a 4-inch Trash pump.
5. Not applicable because Fold-a-Tanks are stationary.

**TABLE 1-45
POINT THOMSON CONDENSATE BLOWOUT DURING SUMMER
MAJOR EQUIPMENT EQUIVALENTS TO MEET THE RESPONSE PLANNING
STANDARD**

RECOVERY TACTIC	NO. TACTICAL UNITS	EQUIPMENT PER TACTICAL UNIT	TOTAL QUANTITY
R-4	1	Fold-a-Tank	1
		2-inch Trash pump	1
		Suction and Discharge hose	Variable
R-6	1	Vacuum Truck (shared with R-22)	1
		DOP pump with power pack	1
		Manta Ray Skimmer	1
		Suction and Discharge hose	Variable
R-17 (nearshore team)	1	Airboat	1
		Boom towing skiff	1
		Boom	500 ft
		Closed tank	1
		Drum/brush combination skimmer	1
R-17 (open water team)	1	Skimming vessel (has built-in MARCO Filter Belt skimmer and storage)	1
		Airboat	1
		Boom	350 ft
		Island Class vessel (shuttles mini-barge; shared between R-17 teams)	1
		Mini-barge (shared between R-17 teams)	2
		3-inch Trash pumps (used with R-22)	1
R-22	1	Fold-a-Tank	2
		4-inch Trash pump	1
		Vacuum truck (shared with R-6)	1
		Suction and Discharge hose	Variable

TABLE 1-46
POINT THOMSON CONDENSATE BLOWOUT DURING SUMMER
NUMBER OF STAFF PER SHIFT TO OPERATE OIL RECOVERY AND TRANSFER
EQUIPMENT

LABOR CATEGORY	TACTIC	NO. TACTICAL UNITS	NO. STAFF PER TACTICAL UNIT	NO. STAFF PER SHIFT
Team Lead	R-4	1	1	1
	R-6	1	1	1
	R-17 (nearshore)	1	1	1
	R-17 (offshore)	1	1	1
	R-17 (shuttle)	1	1	1
	R-22	1	1	1
Skilled Technician	R-4	1	1	1
	R-6	1	2	2
	R-17 (nearshore)	1	2	2
	R-17 (offshore)	1	2	2
	R-17 (shuttle)	1	1	1
	R-22	1	2	2
General Technician	R-4	1	1	1
	R-6	1	1	1
	R-17 (nearshore)	1	2	2
	R-17 (offshore)	1	2	2
	R-17 (shuttle)	1	1	1
	R-22	1	2	2
Vessel Operator	R-17 (nearshore)	1	2	2
	R-17 (offshore)	1	2	2
	R-17 (shuttle)	1	1	1
Equipment Operator	R-6 & R-22 (share a vacuum truck)	1	1	1
Total Staff				25

Note: Total excludes Team Leads because they work as Skilled Technicians or Vessel Operators.

FIGURE 1-16 BLOWOUT DURING SUMMER: EXTENT OF BLOWOUT PLUME

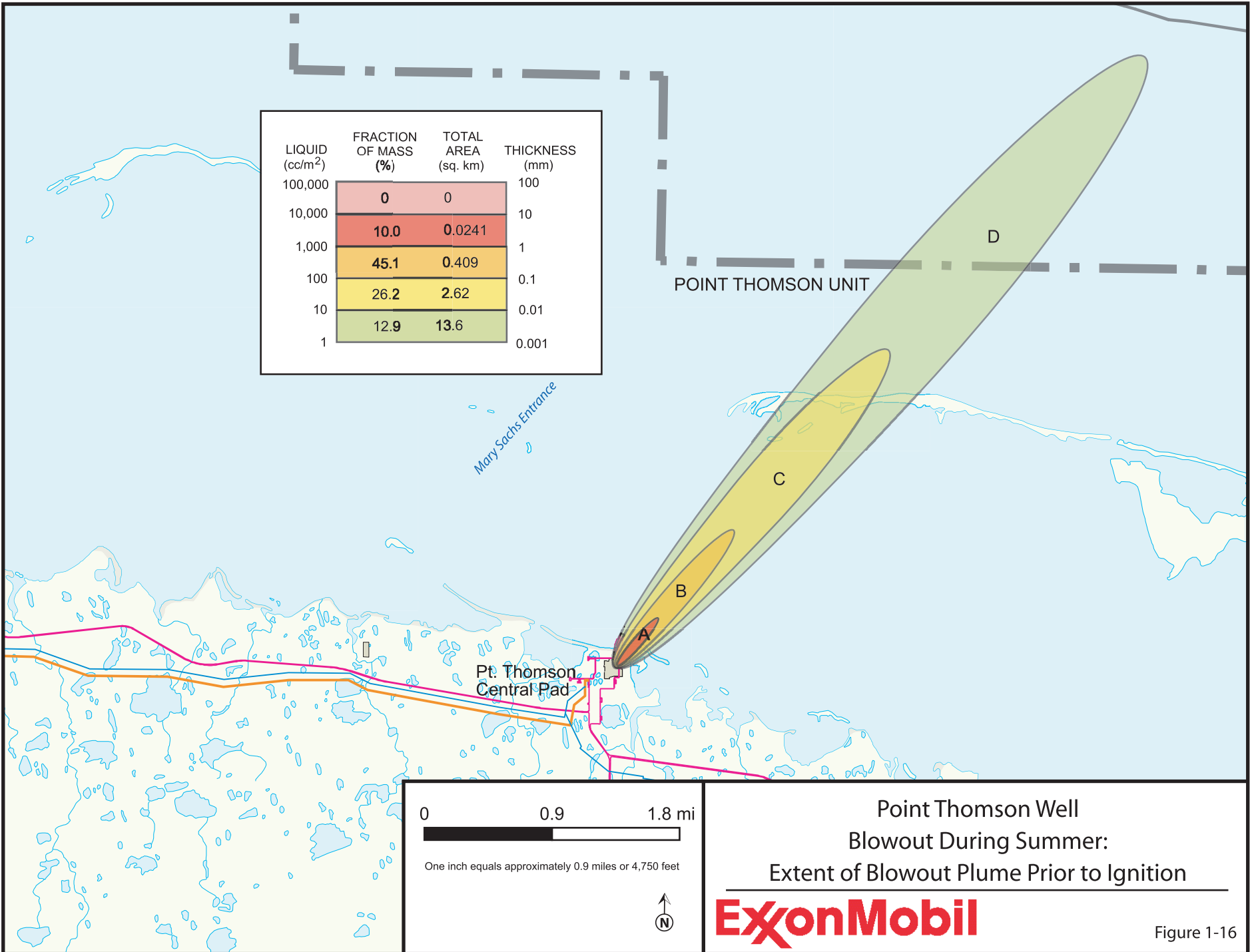
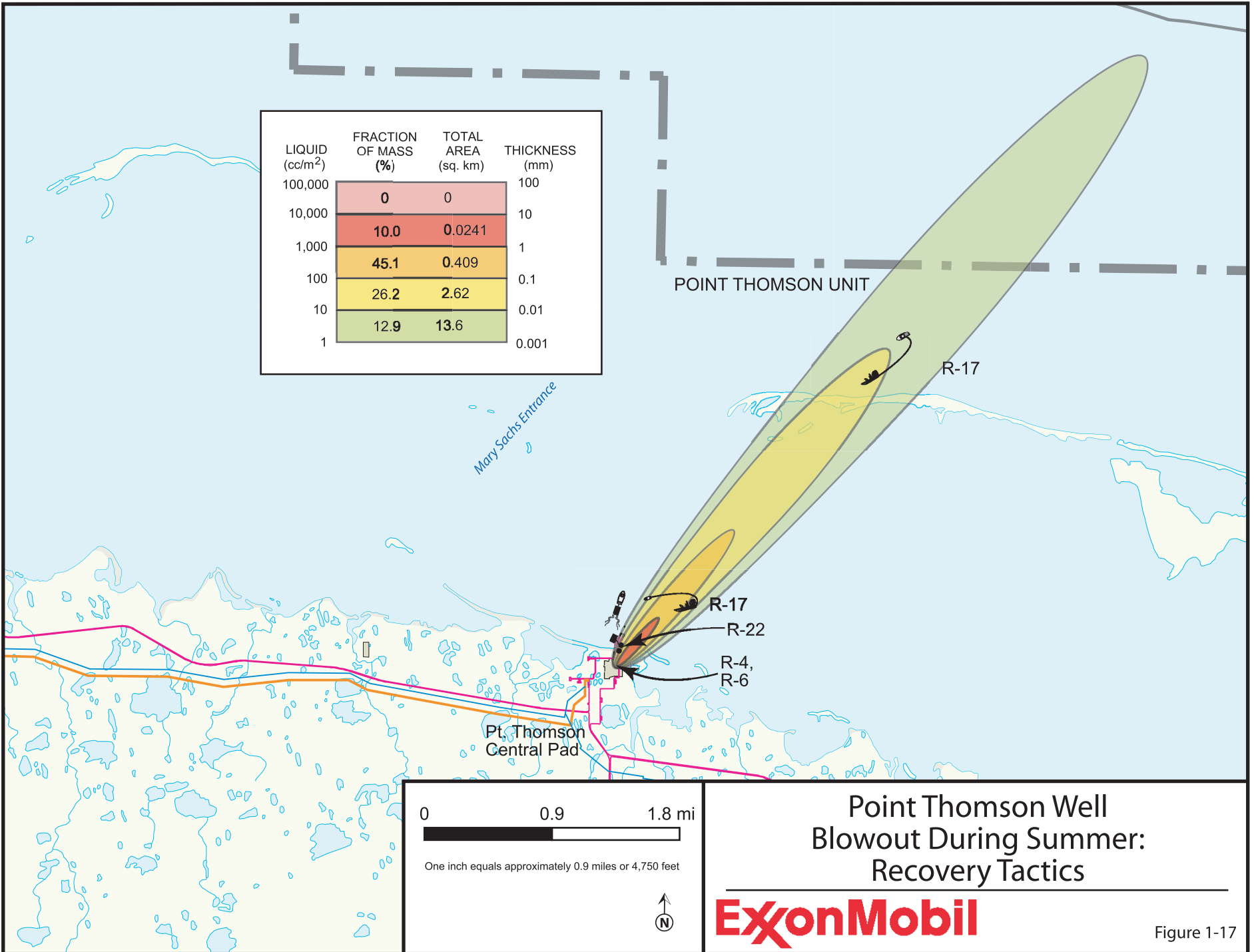

FIGURE 1-17 BLOWOUT DURING SUMMER: RECOVERY TACTICS



THIS PAGE INTENTIONALLY LEFT BLANK

1.7 NONMECHANICAL RESPONSE OPTIONS [18 AAC 75.425(e)(1)(G)]

ExxonMobil will mechanically contain and cleanup oil spills to the maximum extent possible. ExxonMobil will request approval for *in situ* burning of condensate or diesel on land or water surfaces from the FOSC and State On-Scene Coordinator (SOSC) when mechanical response methods prove ineffective or when *in situ* burning can be used as a tool to minimize environmental damage. The term *in situ* burning applies to burning oil that has reached surfaces and excludes ignition of blowout oil plumes and burning of collected waste oil.

1.7.1 Obtaining Permits and Approvals

In situ burning of spilled oil will not occur without approval of state and federal agencies. The ExxonMobil Incident Commander will discuss the option of *in situ* burning with the FOSC and the SOSC. ExxonMobil and ACS will follow ARRT “*In Situ* Burning Guidelines for Alaska” and complete the Guidelines’ “Application for ISB.”

ACS
Tactics B-1
and B-1A

1.7.2 Decision Criteria for Use

In situ burning of spilled oil would be considered under conditions such as the following:

- Mechanical recovery is impractical or ineffective,
- Shorelines are threatened,
- Burning would augment the oil elimination capacity of mechanical recovery,
- Present and forecast wind conditions will carry the smoke plume away from populated areas, or
- A successful test burn has been conducted.

ACS Tactic
B-1

1.7.3 Implementation Procedures

If the Incident Commander decides to use *in situ* burning and obtains the necessary authorization, ACS would carry out the response. See Section 3.7 for a description of implementation and equipment.

ACS
Tactics B-1
through
B-7

1.7.4 Required Equipment and Personnel

ACS maintains the equipment and personnel for *in situ* burning.

ACS Tactic
L-6

1.8 FACILITY DIAGRAMS [18 AAC 75.425(E)(1)(H)]

Diagrams of the Point Thomson facility are provided in this section and in the ACS *Technical Manual, Volume 2, Map Atlas*, Sheets 101 to 104.

ACS
*Technical
Manual,
Volume 2,
Map Atlas*

FIGURE 1-18 POINT THOMSON GAS CYCLING PROJECT VICINITY MAP

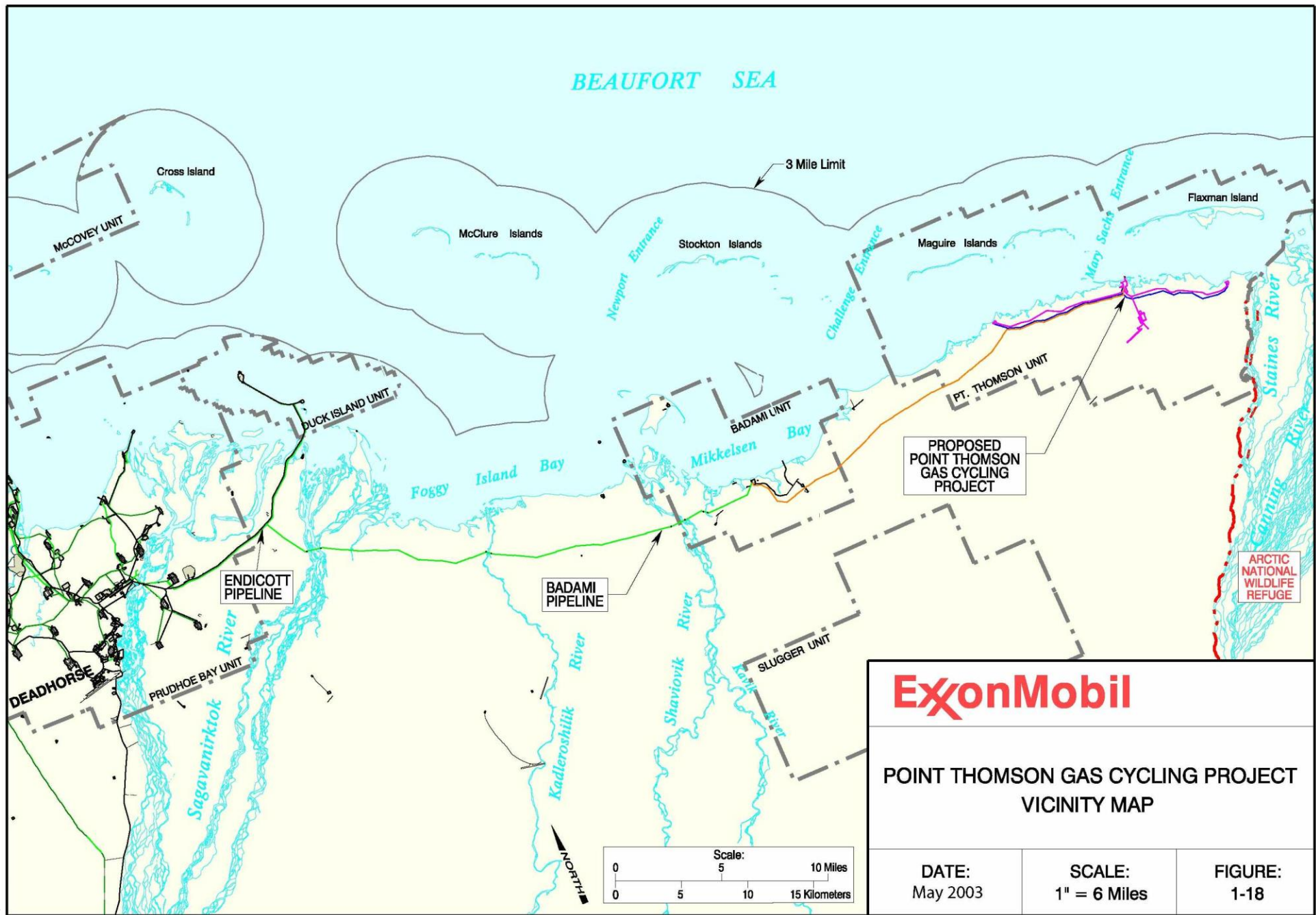

FIGURE 1-19 PIPELINE AND VALVE LOCATIONS

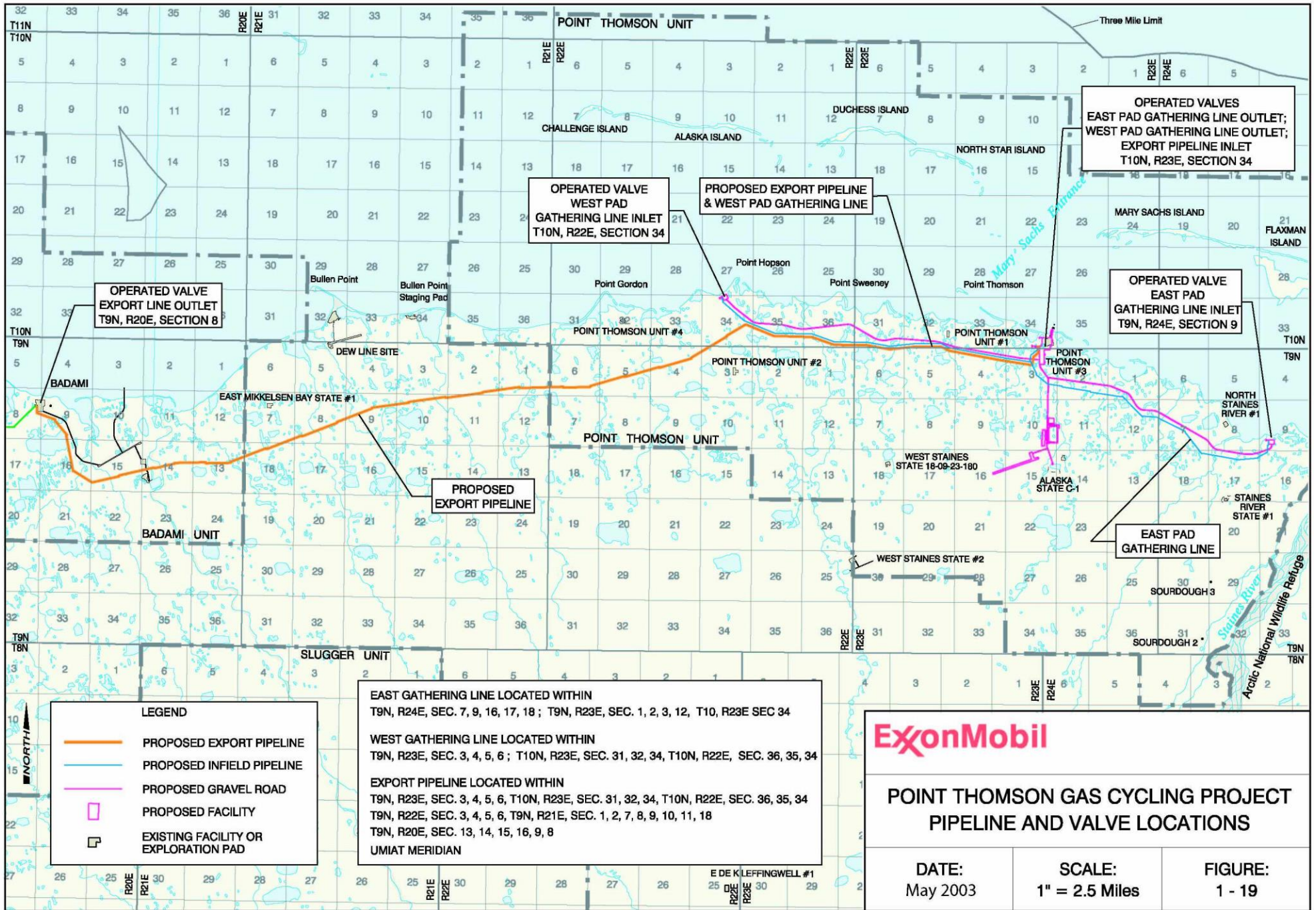
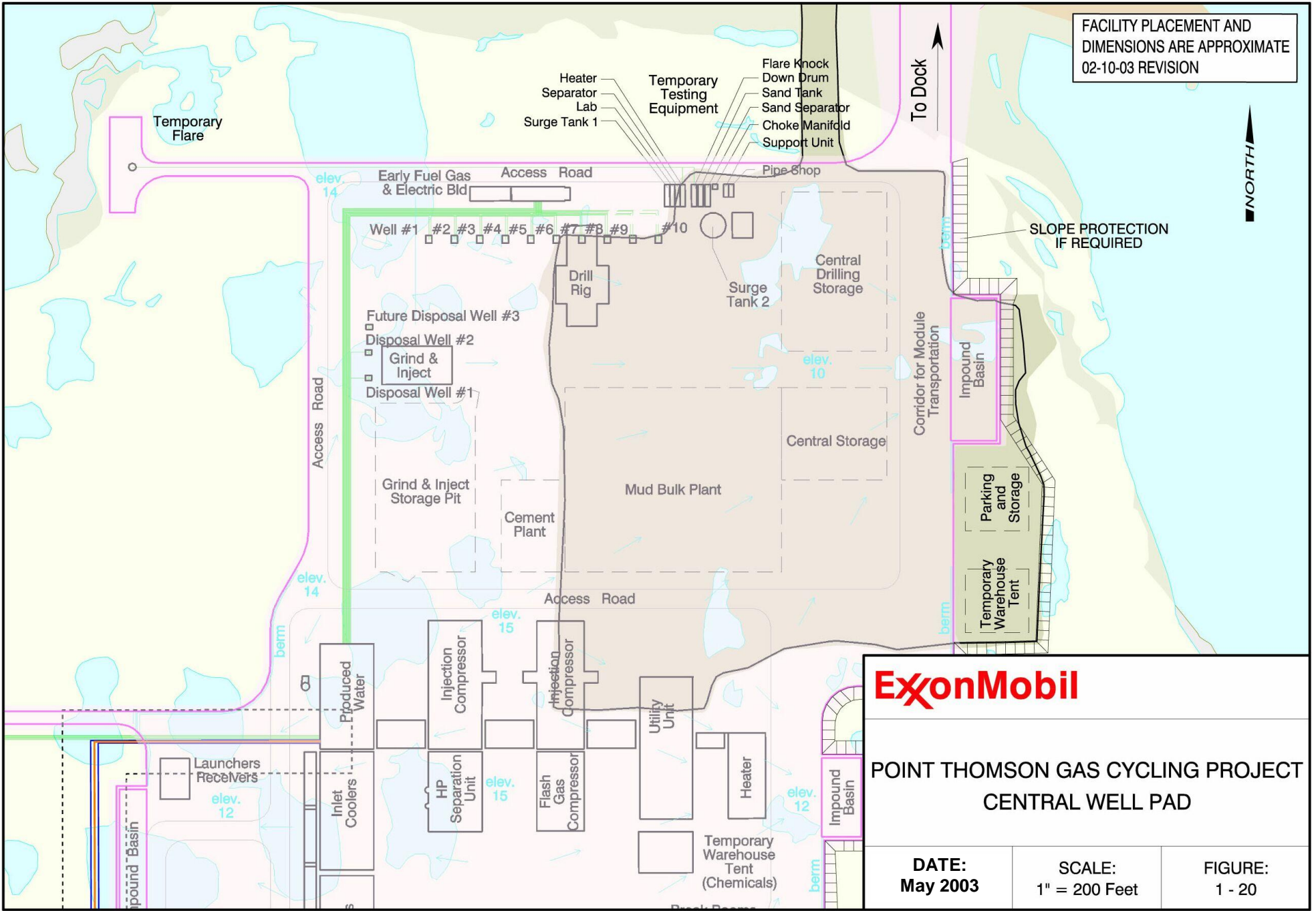

FIGURE 1-20 CENTRAL WELL PAD



FACILITY PLACEMENT AND DIMENSIONS ARE APPROXIMATE 02-10-03 REVISION

ExxonMobil

**POINT THOMSON GAS CYCLING PROJECT
CENTRAL WELL PAD**

DATE: May 2003	SCALE: 1" = 200 Feet	FIGURE: 1 - 20
--------------------------	--------------------------------	--------------------------

FIGURE 1-21 CENTRAL PROCESSING FACILITY

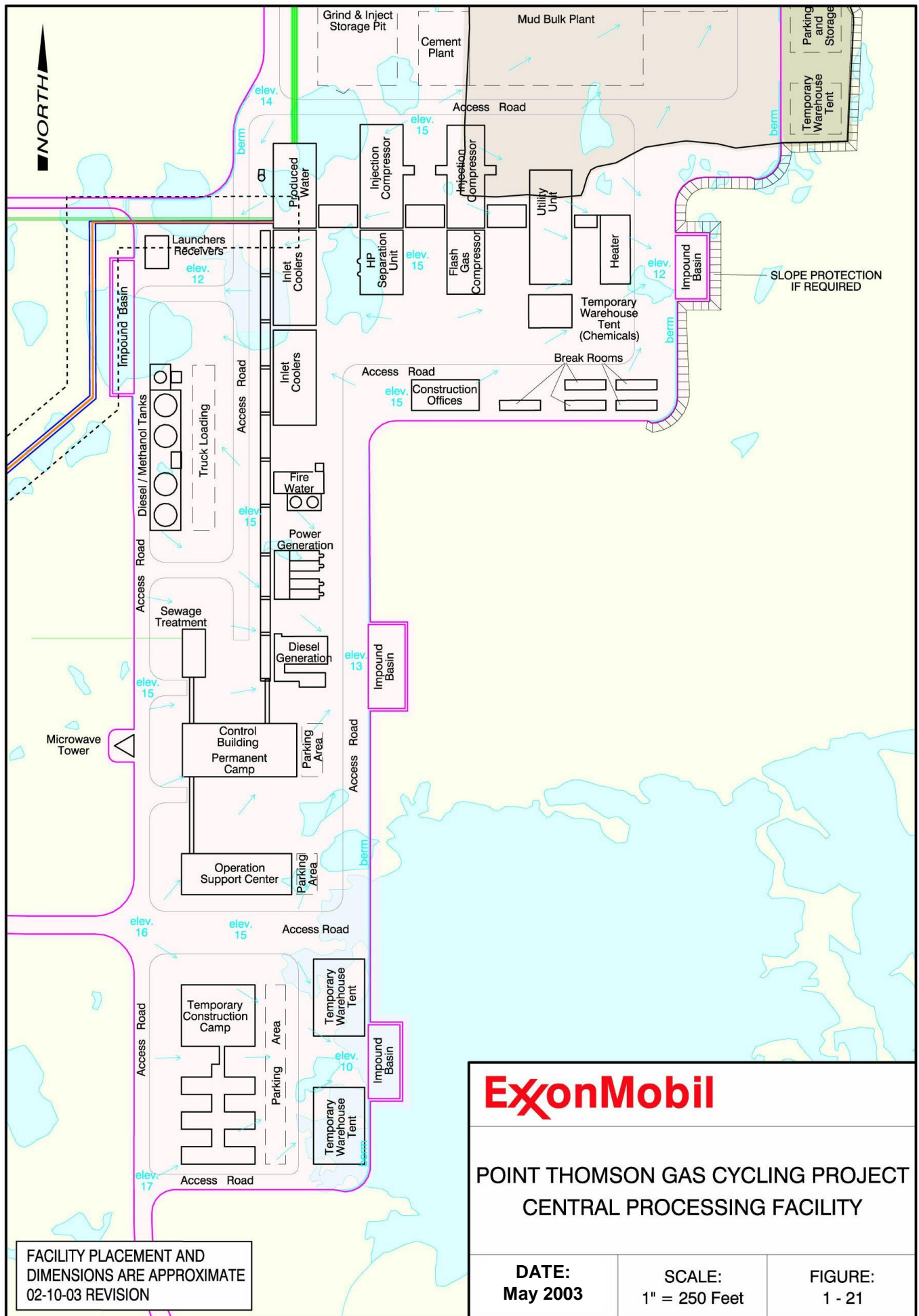

FACILITY PLACEMENT AND DIMENSIONS ARE APPROXIMATE
02-10-03 REVISION

ExxonMobil		
POINT THOMSON GAS CYCLING PROJECT CENTRAL PROCESSING FACILITY		
DATE: May 2003	SCALE: 1" = 250 Feet	FIGURE: 1 - 21

FIGURE 1-22 EAST WELL PAD

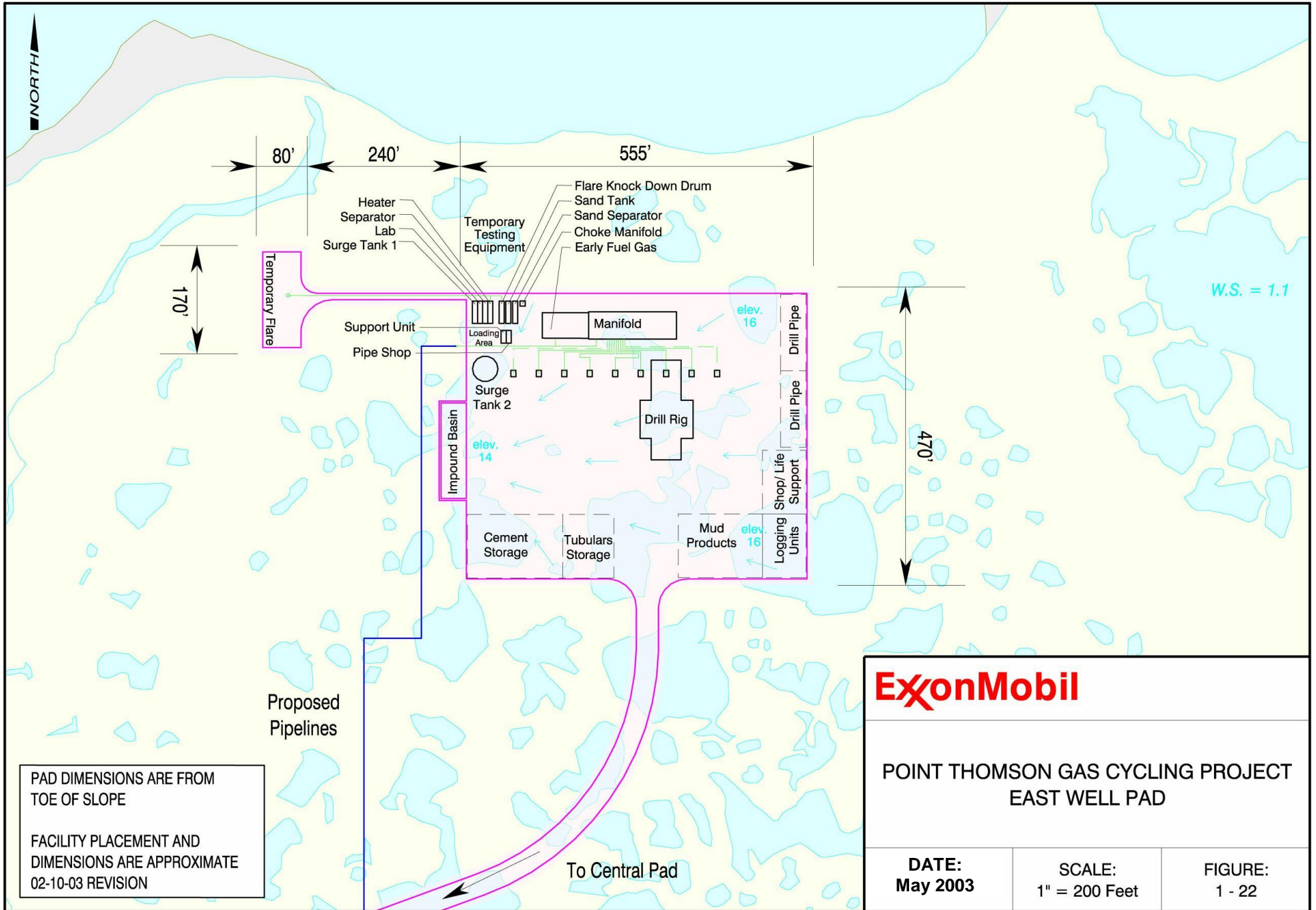

PAD DIMENSIONS ARE FROM TOE OF SLOPE

FACILITY PLACEMENT AND DIMENSIONS ARE APPROXIMATE

02-10-03 REVISION

ExxonMobil

POINT THOMSON GAS CYCLING PROJECT
EAST WELL PAD

DATE: May 2003	SCALE: 1" = 200 Feet	FIGURE: 1 - 22
--------------------------	--------------------------------	--------------------------

FIGURE 1-23 WEST WELL PAD

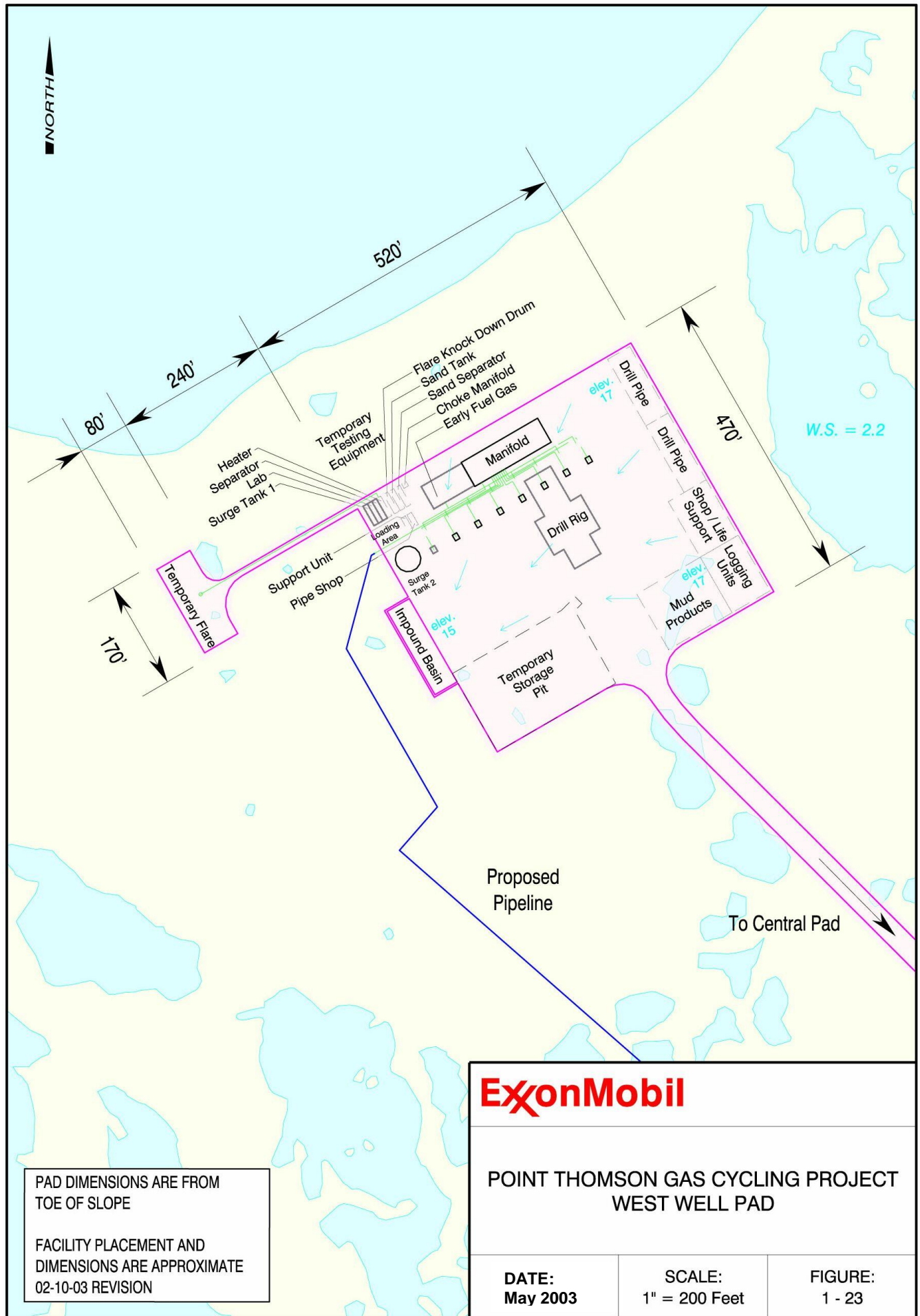

PAD DIMENSIONS ARE FROM
TOE OF SLOPE

FACILITY PLACEMENT AND
DIMENSIONS ARE APPROXIMATE
02-10-03 REVISION

ExxonMobil		
POINT THOMSON GAS CYCLING PROJECT WEST WELL PAD		
DATE: May 2003	SCALE: 1" = 200 Feet	FIGURE: 1 - 23

TABLE OF CONTENTS FOR SECTION 1

1.	RESPONSE ACTION PLAN [18 AAC 75.425(e)(1)]	1-1
1.1	EMERGENCY ACTION CHECKLIST [18 AAC 75.425(e)(1)(A)].....	1-1
1.1.1	Operator and Contacts.....	1-1
1.1.2	Response Levels.....	1-1
1.2	REPORTING AND NOTIFICATION [18 AAC 75.425(e)(1)(B)]	1-4
1.2.1	Internal Notification Procedures.....	1-4
1.2.2	External Notification Procedures.....	1-11
1.2.3	Qualified Individual Notification and Responsibilities.....	1-11
1.2.4	Written Reporting Requirements [18 AAC 75.300]	1-18
1.3	SAFETY [18 AAC 75.425(e)(1)(C)].....	1-18
1.4	COMMUNICATIONS [18 AAC 75.425(e)(1)(D)]	1-19
1.5	DEPLOYMENT STRATEGIES [18 AAC 75.425(e)(1)(E)]	1-20
1.5.1	Transport Procedures [18 AAC 75.425(e)(1)(E)(i)].....	1-20
1.5.2	Notification and Mobilization of Response Action Contractor [18 AAC 75.425(e)(1)(E)(ii)].....	1-21
1.6	RESPONSE STRATEGIES [18 AAC 75.425(e)(1)(F)]	1-21
1.6.1	Procedures to Stop Discharge [18 AAC 75.425(e)(1)(F)(i)].....	1-21
1.6.2	Fire Prevention and Control [18 AAC 75.425(e)(1)(F)(ii)]	1-24
1.6.3	Blowout Response [18 AAC 75.425(e)(1)(F)(iii)]	1-26
1.6.4	Discharge Tracking [18 AAC 75.425(e)(1)(F)(iv)]	1-39
1.6.5	Protection of Sensitive Areas [18 AAC 75.425(e)(1)(F)(v)].....	1-39
1.6.6	Containment and Control Strategies [18 AAC 75.425(e)(1)(F)(vi)].....	1-40
1.6.7	Recovery Strategies [18 AAC 75.425(e)(1)(F)(vii)].....	1-40
1.6.8	Lightering, Transfer, and Storage of Oil from Tanks [18 AAC 75.425(e)(1)(F)(viii)]	1-40
1.6.9	Transfer and Storage Strategies [18 AAC 75.425(e)(1)(F)(ix)].....	1-40
1.6.10	Temporary Storage and Disposal [18 AAC 75.425(e)(1)(F)(x)].....	1-40
1.6.11	Wildlife Protection [18 AAC 75.425(e)(1)(F)(xi)]	1-41
1.6.12	Shoreline Cleanup [18 AAC 75.425(e)(1)(F)(xii)]	1-41
1.6.13	Response Planning Standards [18 AAC 75.430].....	1-42
1.6.14	Response Scenarios [18 AAC 75.425(e)(1)(F)].....	1-47
1.7	NONMECHANICAL RESPONSE OPTIONS [18 AAC 75.425(e)(1)(G)]	1-119
1.7.1	Obtaining Permits and Approvals	1-119
1.7.2	Decision Criteria for Use	1-119
1.7.3	Implementation Procedures	1-119
1.7.4	Required Equipment and Personnel.....	1-119
1.8	FACILITY DIAGRAMS [18 AAC 75.425(e)(1)(H)].....	1-119

LIST OF FIGURES

Figure 1-1	Immediate Spill Notifications	1-5
Figure 1-2	Point Thomson Incident Management Team for Level II/III	1-6
Figure 1-3	Spill Report Form.....	1-12
Figure 1-4	Surface Transport Seasons.....	1-22
Figure 1-5A	general surface intervention options	1-27
Figure 1-5B	Well Ignition Decision Tree	1-28
Figure 1-5C	Relief Well Options During the Year	1-36
Figure 1-5D	Winter Mobilization for Relief Well.....	1-37
Figure 1-5E	Summer Mobilization for Relief Well	1-38
Figure 1-6	Condensate Export Pipeline Spill to Open Water Scenario Vicinity Map.....	1-61
Figure 1-7	Condensate Export Pipeline Spill to Open Water Scenario	1-62
Figure 1-8	Condensate Export Pipeline Spill During Break-Up Scenario Vicinity Map	1-71
Figure 1-9	Condensate Export Pipeline Spill During Break-Up Scenario.....	1-72
Figure 1-10	Diesel Tank Rupture During Summer Vicinity Map.....	1-81

Figure 1-11 Diesel Tank Rupture During Summer	1-82
Figure 1-12 Diesel Tank Rupture During Freeze-Up Vicinity Map	1-91
Figure 1-13 Diesel Tank Rupture During Freeze-Up	1-92
Figure 1-14 Blowout During Winter: Extent of Blowout Plume Prior to Ignition	1-103
Figure 1-15 Blowout During Winter: Recovery Tactics	1-104
Figure 1-16 Blowout During Summer: Extent of Blowout Plume Prior to Ignition	1-116
Figure 1-17 Blowout During Summer: Recovery Tactics	1-117
Figure 1-18 Point Thomson Gas Cycling Project Vicinity Map	1-120
Figure 1-19 Pipeline And Valve Locations	1-121
Figure 1-20 Central Well Pad	1-122
Figure 1-21 Central Processing Facility	1-123
Figure 1-22 East Well Pad	1-124
Figure 1-23 West Well Pad	1-125

LIST OF TABLES

1-1A Immediate Action Checklist	1-7
1-1B Immediate Response and Notification Actions	1-9
1-2 ExxonMobil Contact List ¹	1-13
1-3 Agency Reporting Requirements for Oil Spills	1-15
1-4 Drilling Supervisor Checklist for Immediate Blowout Response	1-29
1-5 Emergency Well Ignition Procedures	1-29
1-6 Conditions for Pre-Authorized Well Ignition	1-30
1-7 Surface Intervention Equipment List	1-32
1-8 Summary of Condensate Characterizations For Release to the Atmosphere (Mole Percent)	1-44
1-9 Condensate Export Pipeline Spill to Open Water Scenario Conditions	1-53
1-10 Condensate Export Pipeline Spill to Open Water Response Strategy	1-55
1-11 Condensate Export Pipeline Spill to Open Water Oil Recovery Capacity	1-57
1-12 Condensate Export Pipeline Spill to Open Water Liquid Handling Capability	1-57
1-13 Condensate Export Pipeline Spill to Open Water Major Equipment Equivalents to Meet The Response Planning Standard	1-58
1-14 Condensate Export Pipeline Spill to Open Water Equipment for Shoreline Protection	1-58
1-15 Condensate Export Pipeline Spill to Open Water Staffing to Operate Oil Recovery and Transfer Equipment	1-59
1-16 Condensate Export Pipeline Spill to Open Water Staffing for Shoreline Protection	1-59
1-17 Condensate Export Pipeline Spill During Break-Up Scenario Conditions	1-65
1-18 Condensate Export Pipeline Spill During Break-Up Response Strategy	1-67
1-19 Condensate Export Pipeline Spill During Break-Up Oil Recovery Capacity	1-69
1-20 Condensate Export Pipeline Spill During Break-Up Liquid Handling Capability	1-69
1-21 Condensate Export Pipeline Spill During Break-Up Major Equipment Equivalents to Meet the Response Planning Standard	1-70
1-22 Condensate Export Pipeline Spill During Break-Up Staffing to Operate Oil Recovery and Transfer Equipment	1-70
1-23 Diesel Tank Rupture During Summer Scenario Conditions	1-75
1-24 Diesel Tank Rupture During Summer Response Strategy	1-77
1-26 Diesel Tank Rupture During Summer Oil Recovery Capacity	1-79
1-27 Diesel Tank Rupture During Summer Liquid Handling Capability	1-79
1-28 Diesel Tank Rupture During Summer Major Equipment for Recovery and Transfer	1-80
1-29 Diesel Tank Rupture During Summer Staffing to Operate Oil Recovery and Transfer Equipment	1-80
1-30 Diesel Tank Rupture During Freeze-Up Scenario Conditions	1-85
1-31 Diesel Tank Rupture During Freeze-Up Response Strategy	1-87

1-32 Diesel Tank Rupture During Freeze-Up Oil Recovery Capacity	1-89
1-33 Diesel Tank Rupture During Freeze-Up Liquid Handling Capability	1-89
1-34 Diesel Tank Rupture During Freeze-Up Major Equipment for Recovery and Transfer	1-90
1-35 Diesel Tank Rupture During Freeze-Up Staffing to Operate Oil Recovery and Transfer Equipment.....	1-90
1-36 Point Thomson Blowout During Winter Scenario Conditions	1-95
1-37 Point Thomson Blowout During Winter Response Strategy	1-97
1-38 Point Thomson Blowout During Winter Oil Recovery Capacity	1-100
1-39 Point Thomson Blowout During Winter Major Equipment Equivalents to Meet the Response Planning Standard.....	1-101
1-40 Point Thomson Blowout During Winter Number of Staff Per Shift to Operate Oil Recovery and Transfer Equipment.....	1-101
1-41 Point Thomson Condensate Blowout During Summer Scenario Conditions.....	1-107
1-42 Point Thomson Condensate Blowout During Summer Response Strategy	1-109
1-43 Point Thomson Condensate Blowout During Summer Oil Recovery Capacity	1-112
1-44 Point Thomson Condensate Blowout During Summer Liquid Handling Capability	1-113
1-45 Point Thomson Condensate Blowout During Summer Major Equipment Equivalents to Meet the Response Planning Standard.....	1-114
1-46 Point Thomson Condensate Blowout During Summer Number of Staff Per Shift to Operate Oil Recovery and Transfer Equipment	1-115

2. PREVENTION PLAN [18 AAC 75.425(e)(2)]

2.1 PREVENTION, INSPECTION, AND MAINTENANCE PROGRAMS [18 AAC 75.425(e)(2)(A)]

2.1.1 Prevention Training Programs [18 AAC 75.007(d)]

ExxonMobil personnel at Point Thomson will receive training in a variety of areas, including general North Slope procedures, spill prevention, environmental awareness, job-specific safety training, and site-specific orientation. Through the initial and annual training detailed below, personnel will receive training in oil spill notification protocols, oil spill source control, and Hazardous Waste Operations and Emergency Response (HAZWOPER). The distribution and use of the *Alaska Safety Handbook*, *ExxonMobil Production Safety Manual*, and, the *North Slope Environmental Field Handbook* will further supplement the routine training program.

The North Slope Training Cooperative (NSTC) program is a 1-day training seminar that is mandatory for everyone who works in the North Slope oil fields. It consists of a series of training videos and lectures covering the following topics:

- *Alaska Safety Handbook* and *ExxonMobil Production Safety Manual*,
- Camps and Facilities Safety Orientation,
- Environmental Excellence,
- Hazard Communication (HAZCOM),
- HAZWOPER Awareness,
- Personal Protective Equipment (PPE), and
- Hydrogen Sulfide.

The NSTC program includes a review of the *North Slope Environmental Field Handbook*, which is made available to everyone working in the North Slope oil fields. The handbook provides a general overview of state and federal environmental regulations and programs applicable to the North Slope oil fields. It summarizes procedures developed by North Slope operators to comply with state and federal environmental regulations. The handbook covers programs specific to air, land, water, wildlife, spills, and waste management. It is supplemented with a site-specific safety manual issued by ExxonMobil.

Upon arrival at the facility, personnel will be provided a site orientation that includes familiarization with the Point Thomson emergency response and evacuation plans.

Point Thomson facility and response staff will also receive training in ExxonMobil Environmental Management Plan awareness and refreshers on fire extinguishers and HAZCOM, as required. Point Thomson facility and response staff which are qualified as pipeline operators under 49 CFR 195 Subpart G will also receive annual training according to the US DOT requirements listed in 49 CFR 195.403. Oil-handling staff receive training and an annual briefing in spill prevention topics.

Point Thomson will use the Operations Integrity Management System (OIMS) to ensure continuous improvement in environmental performance. The OIMS framework consists of 11 elements, as shown in Figure 2-1. The system uses direct input from technical specialists and field personnel, along with information developed through routine loss control and incident investigations, to minimize the potential recurrence of events. ExxonMobil developed OIMS to

FIGURE 2-1
OPERATIONS INTEGRITY MANAGEMENT SYSTEM ELEMENTS

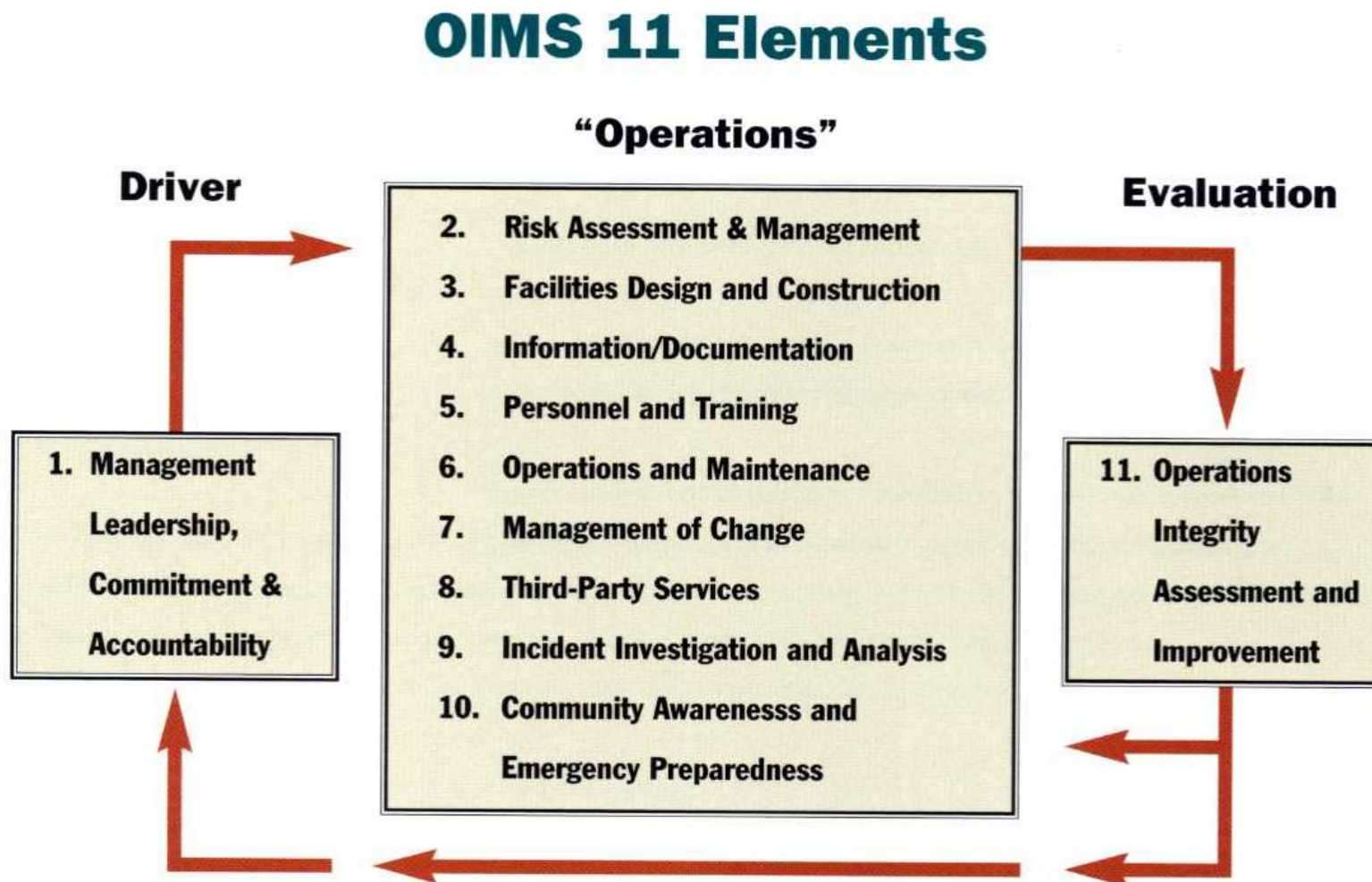

manage safety, health and environmental risks. Elements of the system cover risk assessment and management, personnel training, incident investigation and analysis, and emergency preparedness. A specific Safety Management Plan in OIMS covers safety and occupational health.

Safety and environmental communications and bulletins will be regularly distributed to ensure that specific safety and environmental issues are properly communicated to all personnel. Field personnel will receive electronic and hard copies of these communications. In addition, most supervisors will discuss the communications and bulletins with their crew during safety meetings.

Waste management training (known as “Red Book” training) will familiarize Point Thomson facility personnel with the regulatory classification and disposal requirements for industrial wastes. The training covers classification of wastes, transportation requirements, and a description of each waste disposal facility on the North Slope. The course is mandatory for personnel who sign waste manifests as a generator, transporter, or receiver of waste.

Service company employees will receive instruction to promote safe conduct on the job, including a briefing by responsible supervisors prior to project commencement. Upon arrival in the operating areas, personnel will be instructed in safety and health responsibilities, including rules, procedures, injury reporting, and PPE. Employees will receive copies of and be briefed on the *Alaska Safety Handbook* and *ExxonMobil Production Safety Manual*.

Training records for ExxonMobil Point Thomson employees will be available through the employee’s immediate supervisor or by contacting ExxonMobil’s Anchorage office. Contractors will maintain their own training records. These records will be reviewed annually by ExxonMobil.

The training programs and operational procedures will serve to provide assurance that the likelihood of future spills caused by operator error or procedural deficiencies will be mitigated to the fullest extent.

2.1.2 Substance Abuse Programs [18 AAC 75.007(e)]

ExxonMobil complies with regulations promulgated by the US DOT under 49 CFR 40 that mandate biological testing and supervisory training programs. Point Thomson employees who fall under these regulations (i.e., employees involved in operation, maintenance, and emergency response positions in natural gas, liquefied natural gas, and hazardous liquid pipeline operations) will be required to undergo biological testing for reasonable cause following reportable accidents, alcohol or drug rehabilitation, and on a random basis. Other employees will fall under the Company’s drug testing program. Each of these groups will be tested at a rate of 25 percent per year. Contract personnel will maintain their own records.

ExxonMobil is committed to a safe, healthy, and productive workplace for all employees. ExxonMobil recognizes that alcohol, drug, or other substance abuse by employees will impair their ability to perform properly and will have serious adverse effects on the safety, efficiency and productivity of other employees and ExxonMobil as a whole. The misuse of legitimate drugs, or the use, possession, distribution, or sale of illicit or non-prescribed controlled drugs on Company business or premises is strictly prohibited and constitutes serious misconduct, which will likely result in termination of employment. Possession, use, distribution, or sale of alcoholic beverages on Company premises is not allowed. Being unfit for work because of

use of drugs or alcohol is strictly prohibited and constitutes serious misconduct, which will likely result in termination of employment. While this policy refers specifically to alcohol and drugs, it is also intended to apply to use of inhalants and other forms of substance abuse.

ExxonMobil recognizes alcohol or drug dependency as a treatable condition. Employees at Point Thomson who suspect they have an alcohol or drug dependency will be encouraged to seek advice and to follow appropriate treatment promptly before it results in job performance problems. The Employee Health Advisory Program or medical professional staff will advise and assist in securing treatment. Those employees who follow approved treatment will receive disability benefits in accordance with the provisions of established benefit plans and medical insurance coverage consistent with existing plans.

No employee with alcohol or drug dependency will be terminated due to the request for help in overcoming that dependency or because of involvement in a rehabilitation effort. However, an employee who has had or is found to have a substance abuse problem will not be permitted to work in designated positions identified by management as being critical to the safety and well-being of employees, the public, or ExxonMobil. An employee returning from rehabilitation will be required to participate in a Company-approved after-care program. If an employee violates provisions of the employee Alcohol and Drug Use Policy, appropriate disciplinary action will be taken. Such action cannot be avoided by a request at that time for treatment or rehabilitation. If an employee suffering from alcohol or drug dependency refuses rehabilitation, fails to respond to treatment, or fails to meet satisfactory standards of effective work performance, appropriate disciplinary action, up to and including termination, will be taken. This policy does not require and should not result in any special regulations, privileges, or exemptions from normal job performance requirements.

ExxonMobil may conduct unannounced searches for drugs and alcohol on ExxonMobil-owned or controlled property. ExxonMobil may also require employees to submit to medical evaluation or alcohol and drug testing where cause exists to suspect alcohol or drug use, including workplace incidents. Unannounced periodic or random testing will be conducted when an employee meets any one of the following conditions: has had a substance abuse problem, or is working in a designated position identified by management, a position where testing is required by law, or a specified executive position. A positive test result or refusal to submit to a drug or alcohol test is grounds for disciplinary action, including termination. In all circumstances, ExxonMobil retains the right to take appropriate disciplinary action against an employee in possession of or under the influence of drugs or alcohol.

Contractor and vendor personnel at Point Thomson will also be covered by this policy. Those who violate the policy will be removed from Company premises and may be denied future entry.

In addition to the above policy, it is a requirement of ExxonMobil that, as a component of the selection process, applicants being considered for an offer of employment with ExxonMobil must undergo a drug test.

2.1.3 Medical Monitoring [18 AAC 75.007(e)]

Upon beginning work, new hires will receive an entrance physical to establish baseline health conditions and to determine their fitness for duty. Ongoing health assessments will be conducted as required by the type of work performed according to the requirements of the federal Occupation Safety and Health Administration (OSHA) and the Alaska Department of Safety and Health and/or specific company requirements. Emergency response personnel

will be scheduled for exams biennially unless the examiner determines a need for a more frequent examination. At a minimum, these medical examinations will include a physical, baseline electrocardiogram, vision screening, and blood work.

2.1.4 Security Programs [18 AAC 75.007(f)]

Point Thomson is remotely located in a sparsely populated area and will not be connected to other North Slope communities by a permanent road. Security plans for similar operations in the area include coordination with local and state police agencies when some unusual security concern or event is experienced. There is some use of the onshore area for subsistence use, and local residents may occasionally pass through the Point Thomson Unit. ExxonMobil understands the need for public access and pass-through, and will provide access as necessary without compromising site control and safety issues. Hunting will be carefully managed around pipeline and other production facilities to prevent intentional or accidental damage, and reasonable precautions are taken (e.g., locking critical valves, land equipment buildings) to discourage and prevent vandalism or sabotage.

Security personnel will be responsible for site access control and assist in enforcing many of ExxonMobil's policies. Access to North Slope operations is controlled through Security checkpoints where Security staff record the personnel present in the operating areas. The security badge system provides a method for monitoring personnel. Each employee or contractor wears an identification badge indicating the employee's company and badge number. With this system, Security has the capability to recognize authorization levels and access personal history information in emergency situations. This program will provide for security and safety of personnel moving to and from the site, and at the site.

2.1.5 Fuel Transfer Procedures [18 AAC 75.025]

Onshore Tanks

Fuel tank trucks of three sizes will operate at Point Thomson, as follows:

- Diesel well service truck rated to 5 psig, nominal 3,000 gallons;
- DOT-specification (vent only), mobile fuel diesel trucks, nominal 4,448 gallons; and
- Produced fluids trucks, nominal 12,180 gallons, with pressure safety valves rated for service, each equipped with two manual valves on the loading lines and a drylock fitting.

Fuel transfer procedures have been developed and implemented for North Slope operations. The *North Slope Fluid Transfer Guidelines* describes practices for safe, responsible transfers of diesel, and will be used for Point Thomson operations. Proper use of surface liners and drip pans is described in the *North Slope Unified Operating Procedures (UOP), Surface Liner/Drip Pan Use Procedure*, May 29, 1999. The UOP mandates the use of liners for:

- Vacuum Trucks,
- Fuel Trucks,
- Sewage Trucks,
- Chemical Delivery Units,
- Chemical Transfer Units, and
- Fluid Transfers within Facilities.

In addition, the fuel truck driver will remain at the truck during loading and off-loading according to ExxonMobil procedures provided in Appendix A. Fuel tank trucks will have drylock fittings and at least one manual valve that isolates the tank from the loading and unloading station. Tank liquid levels can be monitored in either a control room or in the operations warehouse. PSVs, heat-traced vent lines, or pressure relief valves will be installed on all the tanks for vacuum or overpressure protection.

The fuel permanent storage tanks will be equipped with high-level alarms which activate an audible horn to signal that the filling operation must be suspended. Permanent fuel storage tanks will be equipped with level-indicating devices and manual isolation valves with check valves to prevent reverse flow.

Within a facility, transfers involving high liquid levels will activate an automatic shutdown valve by way of an electronic level detector that transmits levels continuously to the constantly staffed facility control room. In addition, individuals will be able to contact the control room via telephone, radio, or visit to determine liquid level at any time.

Personnel transferring fuel will have several communication routes to halt a transfer at any time. In addition to manual witness and local action to close the valve, individuals will be able to contact the control room. A contact with the control room will be mandatory for initial access to the facility. A method for communication will be agreed upon at that time.

Clear work authorization procedures will be used. People involved in fluid transfer at the facility will be specifically trained in accordance with fluid transfer guidelines described in the *North Slope Environmental Field Handbook*.

The fuel tank-truck loading area will be equipped with containment docks to park trucks on during fluid transfer. Fuel storage tanks will be loaded and off-loaded using strict procedures. For transfers between trucks and tanks, manual shutoff valves will be readily available to the truck operator to stop transfers. Trucks will be continuously staffed during fluid transfers. Personnel involved in the transfer will have explosion-proof radios.

Effective communication and planning will be key factors in preventing spills. Pre-job safety meetings will provide employees with information on their role in the overall scope of the work, review guidelines, and stress the importance of avoiding spills.

Fuel flow diagrams, fuel transfer procedures, valving details, and safety precautions for the drill rig will be listed in the drilling contractor's SPCC plan. The SPCC plan for each drill rig will be kept on-site during drilling activities.

Transfers from Barges

The diesel storage tanks will be filled during the summer by transfer from a barge. The barge will be moored to the dock and connected to the tanks via fuel hose. The barge and transfer hose to shore will be surrounded by oil spill containment boom during the entire transfer. Each fuel hose connection will employ a drip pan, and the entire transfer will be closely monitored by barge personnel and facility personnel in accordance with the USCG *Fuel Transfer Operations Manual*. This manual will be submitted to USCG at least 60 days prior to fuel-transfer operations and will be maintained at the Point Thomson facility. Personnel will monitor the hose and the tank level throughout the transfer and will be in communication via radio or hand signals to ensure that the transfer can be quickly stopped if necessary.

Diesel will be brought to the facility during the summer months, and consequently, the transfers will take place during daylight hours. Facility personnel and barge personnel will complete a Declaration of Inspection prior to each operation. The Declaration of Inspection describes communications procedures, start-up and topping-off procedures, and assures that people involved in the transfer have a common understanding of the transfer process. The Declaration of Inspection will be located in the USCG *Fuel Transfer Operations Manual*. In accordance with 18 AAC 75.465, the facility operations leader will do the following:

- Verify that the vessel has an approved State of Alaska contingency plan by viewing the certificate of approval. The response action plan section of the contingency plan must be on board the vessel.
- Complete and sign the contingency plan verification log.
- Submit a copy of the log to the ADEC within the first five days of the month following the transfer.

The transfer hose must have a minimum design burst-pressure at least four times the sum of the relief valve setting plus the static head pressure of the transfer system where the hose is installed (33 CFR 154.500).

2.1.6 Operating Requirements for Exploration and Production Facilities [18 AAC 75.045]

General Facility Requirements

Flow Tests

Liquid hydrocarbons produced during a formation flow test or other drilling operations will be collected and stored in a manner that prevents the liquid hydrocarbon from entering state land or waters. Flow-test liquid hydrocarbons may flow directly to the CPF or will be stored in mobile tanks or the well cleanout tank. Flow-test oil liquids will be stored in mobile tanks, re-injected, or piped to process facilities. Well flow testing and drilling operations will be staffed 24 hours a day. At each shift change, drill site personnel will inspect tank levels and all tankage, sumps, and drains for indications of liquid hydrocarbon leaks. Piping, valves, glands, wellheads, pumps, and all other machinery will also be visually inspected as part of the shift-change routine.

Platform Integrity Inspections and Isolation Valves for Pipelines Leaving Platforms

These requirements do not apply.

Drip Pans and Curbing

Drip pans and curbing will be provided at transfer locations.

Catch Tanks

These requirements do not apply.

Oil Storage Tanks

Oil storage tanks will meet the requirements of 18 AAC 75.065 and .075. Information pertaining to oil storage tanks is in Sections 2.1.10 and 2.1.11 and in Appendix B.

Piping

Piping will meet the requirements of 18 AAC 75.080. Information pertaining to facility piping is in Sections 2.1.9 and 4.9.2.

Well Houses and Well Cellars

Well houses will be sturdy metal frame and panel construction. If an incident occurs that results in a fluid leak inside a well house, the well house walls and roof will confine spray or mist to the inside of the well house.

The well cellar will be a 10-foot by 10-foot square metal unit and will surround the wellhead. There will be insulation between the 20-inch and 34-inch conductors. The insulation will be sealed in place at both the top and bottom to prevent water from getting in between the pipes. The 20-inch and 34-inch conductors will be welded; the connections will not be threaded.

2.1.7 Blowout Control [18 AAC 75.425(e)(1)(F)(iii)]

Well Control Training

ExxonMobil will require certified well control training for drilling supervisors, operations superintendents, drilling engineers, contractor rig drillers, tool pushers, assistant drillers, derrickmen, and other appropriate personnel through an operations training program with a professional organization and in accordance with AOGCC regulations. The curricula will consist of training in blowout prevention technology and well control and Training to Reduce Unexpected Events (TRUE), and result in certification of participants.

TRUE will involve a multifunctional team made up of rig contractor, service company, and operator personnel prior to commencing operations, which will focus on increasing knowledge and awareness to prevent and deal with potential hazards at Point Thomson. The training will be based specifically on Point Thomson development wells, and its goal will be to provide site-specific solutions to potential problems before they occur. Potential hazards will be defined by the team, including well control and lost returns, and action plans will be developed to identify roles and responsibilities, warning signs, how to react to an event, and lines of communication. Special emphasis will be placed on abnormal pressure detection and well control. The training will also establish a team concept and a team approach to identifying and solving problems.

Blowout Prevention

Drilling and completion fluids will provide primary well control during drilling and workover operations. The fluids are designed to exert hydrostatic pressure on the wellbore. The pressure being exerted will exceed the pore pressures within the subsurface formations, preventing undesired fluid flow into the wellbore. Surface-mounted blowout preventer equipment (BOPE) will provide secondary well control. In the event that primary well control is lost, the surface equipment will be used to contain the influx of formation fluid and then safely circulate it out of the wellbore.

The tree, associated valves, and control systems will provide well control during production of the wells. These systems will provide several layers of redundancy to ensure pressure containment is maintained. In the event of a major release of hydrocarbons or a blowout, the response to the situation may involve use of a relief well drilling rig or other well-work equipment to regain well control.

Well Control Planning

Well control will begin during the well planning phase. ExxonMobil has developed an Integrated Pore Pressure Prediction (IP3) Team consisting of reservoir engineers, geologists, drilling engineers, and computer modelers. The IP3 Team will analyze seismic data, well data from exploration wells, and geologic models to predict pore pressure and fracture gradients, and to develop a detailed understanding of the reservoir (Figure 2-2). The use of advanced technology will enable accurate prediction of formation behavior as wells are drilled, and allows the engineer to plan a well that minimizes the risk of a well control incident. In addition, bottom-hole pressure data from other wells in the area and seismic data will be reviewed to ascertain the expected bottom-hole pressure at the proposed well location.

Engineers will use the bottom-hole pressure predictions to design a drilling mud program with sufficient hydrostatic head to overbalance the formation pressures from surface to total well depth. Other factors influencing the mud weight design are shale conditions, fractures, lost circulation zones, under-pressured formations, and stuck-pipe prevention. The well casing program is designed to allow for containment and circulation of formation fluid influx out of the wellbore without fracturing open formations.

Planning is done in accordance with AOGCC requirements. The operator policies and recommended practices are, at a minimum, equivalent to AOGCC regulations.

Well Control During Drilling

Inspection of Well Control Equipment

Prior to rig acceptance there will be a comprehensive inspection and testing program performed on the drill rig. Typical items included within this program are:

- BOPE is tested to the full rated working pressure (10,000 psi).
- Choke manifold equipment is tested to the full rated working pressure.
- BOP accumulator unit is tested to confirm that closing times meet American Petroleum Institute (API) standards and meet or exceed AOGCC requirements.
- Precharge pressure and total volume of the accumulator bottles are verified.
- New ring gaskets and seals between each BOP component are installed.
- Pressure integrity testing of the high-pressure mud system is done.
- Inspection of drill string and bottom-hole assembly (BHA) components to the most stringent "T.H. Hill DS-1 Category 5 level" is done. "T.H. Hill DS-1 Category 5 level" refers to an inspection and qualification document written by T.H. Hill Associates, Inc., that is considered industry standard for drill string and BHA inspections and quality control of the drill string equipment.

FIGURE 2-2
TECHNOLOGY INTEGRATION WITH IP3

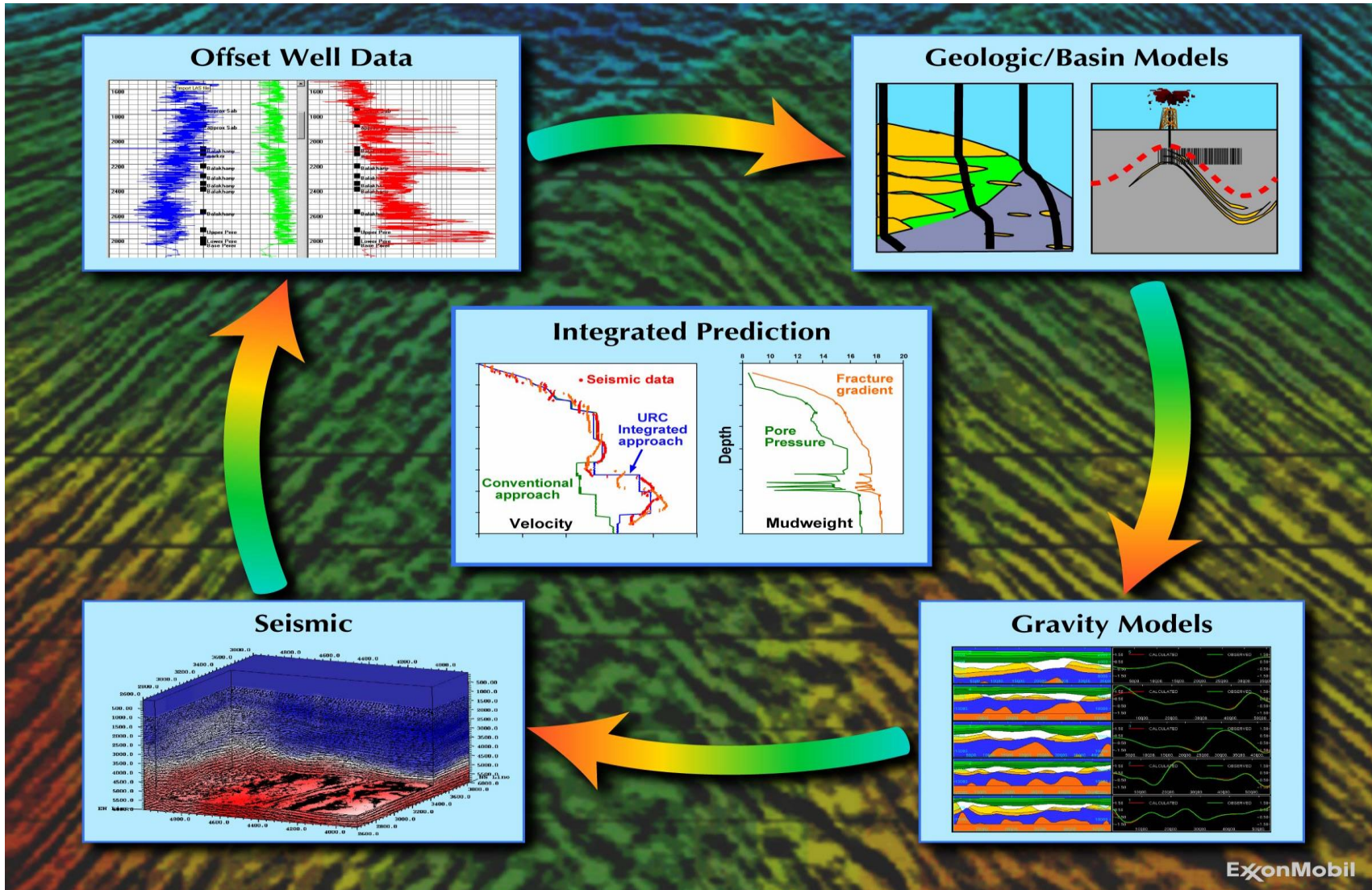

ExxonMobil

After successful completion of testing and qualification of the rig BOPE the rig will be accepted for drilling service at Point Thomson. Routine functional and pressure testing during future drilling operations will be conducted in compliance with ExxonMobil and AOGCC requirements.

Methods to Avoid Intersecting Nearby Wells

During drilling operations, there may be a remote chance of intersecting nearby wells producing gas from deeper hydrocarbon reservoirs. The PTU development has been designed with 40-foot well spacing, surface controlled subsurface safety valves (SCSSV) at 4,500-foot total vertical depth (TVD), and directional plans which kick-off the wells at 2,000 feet or shallower. The combination of these design features eliminates the possibility of intersecting another well below an SCSSV, reducing the risk of an uncontrolled blowout.

However, extensive “anti-collision” drilling practices are implemented by the operator and contract directional drilling staff. In the planning stages, survey tool accuracy, downhole equipment types, and directional uncertainties will be converted into a graphical representation with appropriate “close approach” tolerance lines (i.e., drill vs. no drill). Potential zones of near-well interference will be documented and incorporated into the final directional drilling plan. In cases of known interference, either the new well trajectory will be altered or plans will be made to shut in (close SCSSV and vent hydrocarbons above SCSSV) the existing well while drilling the new well. If tolerance lines protecting existing wells are approached during actual drilling operations, drilling operations will cease until a detailed quantitative risk assessment (QRA) can be performed. Drill-ahead QRAs are most often performed on close approach/tolerance line issues. If close approach/tolerance line issues arise while drilling, QRAs will be combined with more rigorous and frequent directional surveying and sometimes with updated wireline directional surveys in the potential intersect well to reconfirm well placement.

Well Control During Surface Hole Drilling

During surface hole drilling a shallow gas blowout can occur when a small, high-pressure volume of trapped gas is encountered. This causes a rapid unloading of the wellbore fluids and gas at the surface in a very short time. A diverter, installed at the wellhead, will be used to divert the shallow gas kick away from the drilling rig. Development wells will use a diverter for drilling surface-hole sections until it can be demonstrated that shallow hazards do not exist on each pad. ExxonMobil will employ this method during surface-hole drilling unless a waiver is received from AOGCC indicating that diverter use is not necessary. A shallow gas blowout will not contain liquid hydrocarbons.

Well Control While Drilling Below the Surface Hole

The surface-mounted BOPE to be used by ExxonMobil exceeds the standards as defined in AOGCC regulation 20 AAC 25.035. The BOPE will be installed after the surface casing is run and cemented. The surface casing is the first string of casing after drilling out from underneath the conductor or structural casing. The surface casing will be set over all potential areas of subsurface drinking water and at a depth that will allow for sufficient formation strength to provide an anchor for the BOPE.

During drilling operations below the surface-hole, the full BOP stack will be necessary because of potential for an influx from the reservoir or other major hydrocarbon zones.

Should an influx occur, the BOP will be used to close in the well, providing a barrier against release of formation fluids to the atmosphere.

BOPE consists of:

- A minimum of four 13 5/8-inch, 10,000 psi working pressure (WP) ram-type preventers;
- One 13 5/8-inch annular preventer (rated to 10,000 psi);
- Choke and kill lines that provide circulating paths from/to the choke manifold;
- A two-choke manifold that allows for safe circulation of well influx out of the wellbore; and
- A hydraulic control system with accumulator backup closing capability as defined in AOGCC regulation 20 AAC 25.035, as a minimum.

Once installed, the BOPE will be tested according to AOGCC requirements. AOGCC field inspectors will typically witness these pressure tests. The AOGCC may allow for an extension past the weekly duration depending on ongoing operations.

Well Control Monitoring and Procedures

Automatic and manual monitoring equipment will be installed to detect abnormal variation in the mud system volumes and drilling parameters. If an influx of formation fluid is taken into the wellbore, the BOPE will be used to immediately shut in the well.

Each well will be drilled according to a location-specific, detailed well plan. While drilling, the well will constantly monitored for pressure control. The mud weight (the primary well control mechanism) will be monitored and adjusted to meet actual wellbore requirements. Too low of a mud weight could under-balance the well, and may result in an influx of formation fluids. Too high of a mud weight may result in lost circulation to a weak formation, which could then lead to a drop in fluid level and an under-balanced condition. Generally, a fairly broad range of mud weight will be used to provide the proper well control for the hole conditions encountered.

If an influx of formation fluid (kick) occurs, secondary well control methods will be employed. Constant monitoring of the total fluid circulating volume and other drilling parameters will ensure that a kick is quickly detected. The well annulus will be shut in using the BOPE. The drill pipe will be shut in by a downhole check valve near the bit and a surface-mounted valve. This will contain the influx and any associated build-up of surface pressure. It will also prevent further influx of formation fluid into the wellbore. Surface pressures will be allowed to stabilize and will then be measured. The pressure readings will enable the calculation of the new kill-weight mud density needed to regain primary well control. A standard well-kill procedure will be implemented to circulate the kill-weight mud and safely remove kick fluids from the hole. Mud-gas separators and degassers will be used to remove gas from the mud as it is circulated out of the hole. After this procedure is completed, the kill effectiveness will be confirmed and the well will be opened up and the fluid levels monitored. Drilling operations will resume when monitors are normal.

BOP drills will be performed on a frequent basis to ensure the well is shut in quickly and properly. The Drilling Supervisor, toolpushers, drillers, derrickmen, and mud engineers at Point Thomson will have International Association of Drilling Contractors- (IADC) certified training renewed every two years in well control. The certified training program will include hands-on simulator practice at recognizing kicks, well shut in, and circulating the kicks

out of the wellbore. The success of this training is evidenced by the fact that actual kicks are routinely circulated out and the well made safe.

Backup systems and procedures will be available for surface control of a kick if the above procedure fails to provide the required control. Surface pressures in the annulus and drill pipe provide the required information to determine what is happening downhole. *Bullheading* of formation fluids in the wellbore back into the formation may be required. Pumping down both the annulus and the drill pipe at the same time and forcing the fluids back into the formation can accomplish this. The well is then circulated with kill-weight mud. If it is necessary to bleed off annulus pressure, the choke can be adjusted to control formation fluids. Another technique employed for an underground blowout situation (uncontrolled flow of formation fluids from one formation into another) is the dynamic kill procedure. This entails pumping the kill fluid at a rate high enough to overcome the flowing zone and stop the flow. Depending on the situation, other variations of these basic techniques may be used. Although very unusual, a kick that cannot be killed by normal procedures sometimes occurs. In this case, the use of more detailed procedures is required.

Well Control During Completion

Completion operations (i.e., running the production tubing and associated equipment, perforating the well, and installing the Christmas tree) will occur in a cased hole after the final casing string/liner has been set, cemented, and pressure-tested. Prior to perforating, the cased hole and BOPs provide barriers for running tubing. After installation of tubing, the cased hole, SCSSV, and back pressure valve in tubing hanger provide barriers for nipping down the BOP and nipping up the Christmas tree. The tree and SCSSV provide barriers after perforating the well. During completion operations, well control will be maintained through a minimum of two barriers. Mechanical barriers will be used during completion. Kick-detection equipment and kick management (i.e., equipment, people, training, procedures) are described in the sections above.

Well Control During Workovers

Much of the information provided for well control during drilling is also relevant for rig workover operations. Actual production pressure data will be used to establish workover fluid weights much like offset data are used to establish drilling fluid weights. A minimum of two mechanical and/or fluid barriers will be used prior to removing Christmas trees and installing BOP stacks.

BOPE will also be installed during workover operations. The BOPE is capable of controlling the maximum expected wellhead pressure.

Well Control During Wireline/Coil Tubing Interventions

During intervention operations, a minimum of two mechanical barriers will be maintained at the surface. Coil tubing servicing (as opposed to drilling) and wireline operations will be carried out through the Christmas tree. Coil tubing uses high-pressure hydraulic pack-off as the primary well control mechanism, plus a BOP stack consisting of both pipe rams and blind/shear rams.

Wireline also uses a hydraulic pack-off and lubricator as primary well control mechanism, plus a BOP stack with wireline rams.

Well Control During Production

The “Christmas tree” valve configurations for production wellheads on North Slope wells have a minimum of one hydraulically actuated master SSV that can shut in the well, plus additional manual backup valves. Production wells at Point Thomson will be equipped with automatic hydraulic SSVs on the flowline wing valve in addition to the actuated master valve. This is in compliance with AOGCC 20 AAC 25.265. Production wells will also be equipped with SCSSVs.

Both automatically actuated SSVs are connected to the ESD system. In the event of a production shutdown or control-line pressure loss, the valves will automatically shut and wells will cease producing. The SSVs can also be remotely actuated by Point Thomson personnel to shut in production. The SSVs are a “fail-closed” design (loss of hydraulic pressure results in the SSVs closing). If the SSVs do not provide a 100 percent seal, two manual valves on the tree can be opened/closed by personnel. In the event of a leaking flange, valve, or tree/wellhead, component production can be stopped and remedial actions taken depending upon severity. This may or may not involve removing the tree.

Christmas tree SSVs and downhole SCSSVs are integral to the ESD system. The ESD system allows for complete surface isolation from several remote locations. Activation of the individual wellhouse ESD systems will result in surface (SSV) and subsurface (SCSSV) isolation, effectively shutting in the wells.

2.1.8 Leak Detection, Monitoring, and Operating Requirements for Crude Oil Transmission Pipelines [18 AAC 75.055]

Although a specific leak detection system manufacturer has not been selected, current analysis of the pipeline leak detection technology indicates that capabilities equivalent to those previously identified as BAT for similar pipelines can be achieved for the Point Thomson condensate export pipeline. The Point Thomson condensate export pipeline leak detection system will meet the requirements of 18 AAC 75.055 by means of the following:

- Continuous capability to detect a daily discharge of not more than 1 percent of daily throughput,
- Flow verification capability through an accounting method at least once every 24 hours,
- Weekly aerial surveillance for inaccessible pipelines, and
- Ability to stop incoming flow of condensate within one hour after discharge detection.

Leak detection for the condensate export pipeline will consist of monitoring flow and pressure variations in the pipeline, and visual surveillance. The pipeline leak detection system will monitor the condensate export pipeline from the CPF to the Badami tie-in. Detailed information on leak detection system components is found in Section 4.7.

For safe operations, the condensate export pipeline system will include state-of-the-art leak detection instrumentation interconnected to the process facilities via a Supervisory Control and Data Acquisition (SCADA) system. Instrumentation will be designed to help operators recognize potential problems including communication failures, instruments out of range, conditions that may indicate loss of wiring integrity, and other hardware malfunctions.

Isolation valves will be installed at the CPF and Badami tie-in. In addition to the valves, the equipment involved in the leak detection system includes the following:

- Flow meters installed at the inlet and outlet of the pipeline,
- Pressure and temperature indicators at each flow meter location (to improve the response time of the system), and
- A communications link with the SCADA system capable of updating the information as required by the leak detection system.

The system will be calibrated to detect a daily discharge equal to not more than 1 percent of daily throughput. Mass balances will be performed over several specific time intervals. It should be noted that leak tolerance thresholds may be adjusted to prevent nuisance alarms. Flow calculations and/or visual surveillance of the pipeline may be considered by the production control operator before a pipeline shutdown. Visual spill detection for the pipeline will be facilitated by the aboveground construction where pipeline valves, flowline connections, and most associated equipment is visible.

In the event of a catastrophic rupture of the pipeline, the control operator would immediately detect a total loss of pressure while simultaneously observing no reduction in flow. Confirmation would take several minutes, leading to immediate shutdown of the pipeline. In the event of a chronic leak, an integrity alarm will sound if there is a volume variance above specified limits for the related time intervals. The board operator would then proceed through a series of steps to determine the cause of the alarm. Verification of a leak would result in pipeline shut-in. Incoming flow can be stopped within one hour of discharge detection.

2.1.9 Facility Piping Requirements for Oil Terminal, Crude Oil Transmission Pipeline, Exploration, and Production Facilities [18 AAC 75.080]

Corrosion Management Program

Point Thomson's Corrosion Control Program is a part of the Point Thomson Corrosion Management Program, which covers flowlines, well lines, wellheads, headers, pressure vessels, and tanks, as well as other field and facility piping systems throughout Point Thomson. This section describes corrosion management for facility piping.

Corrosion control is the action of preventing or reducing corrosion to acceptable levels. Corrosion control measures encompass a range of alternatives including chemical inhibition, materials selection, coatings, cathodic protection, and process control. These may be applied individually or in combination. Corrosion monitoring is the measurement of success of the corrosion control activities. In this context, corrosion monitoring is taken to mean any activity that monitors corrosion.

The control and monitoring programs are linked, with the monitoring elements providing feedback on the success of the control elements, as shown in Figure 2-3.

Monitoring programs track the performance of the control programs, giving feedback over time. Examples include corrosion probes and coupons. They are not used to monitor pipe wall corrosion directly, but provide performance indicators of the effectiveness of corrosion control inspection programs that share similarities with monitoring programs that measure corrosion directly. Inspection provides documentation of equipment fitness for service. Examples include ultrasonic testing, radiographic testing, and smart pig inspections.

**FIGURE 2-3
THE RELATIONSHIP BETWEEN CORROSION CONTROL AND MONITORING
PROGRAMS**

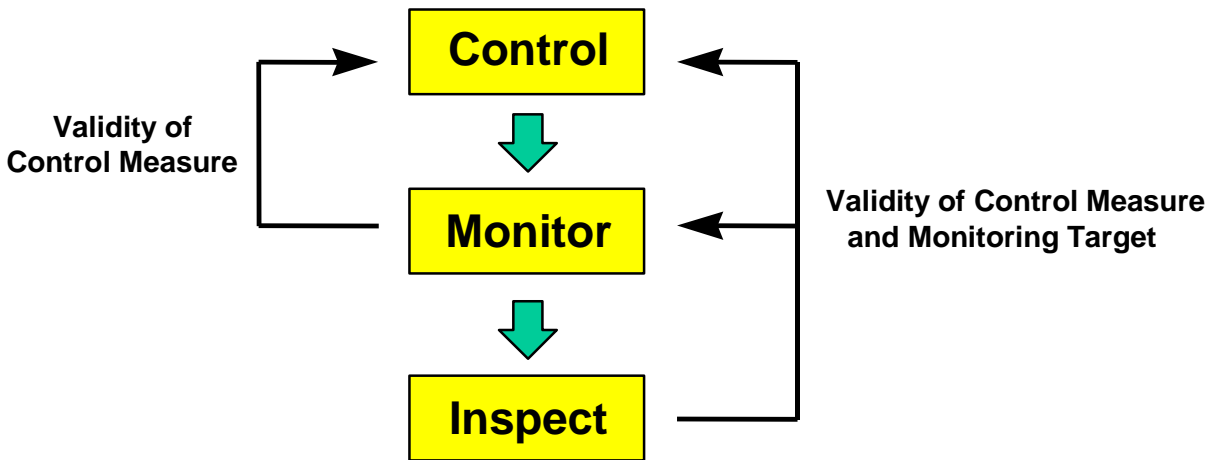

Corrosion Control

The applied corrosion control measures reflect the active or potential corrosion mechanisms in the relevant system. For Point Thomson’s gathering and export pipelines, these can be broadly subdivided into internal and external corrosion mechanisms.

Internal Corrosion: Internal corrosion is not anticipated for the Point Thomson condensate export pipeline, as only “sweet”, dehydrated condensate with a maximum water content of 0.3 percent will be transported through the pipeline. Internal corrosion is not anticipated for the gathering lines as the metallurgy of the pipe is chosen to resist any anticipated corrosive products. As a prudent design measure, internal and external corrosion, although unlikely, will be inspected using smart pigs.

Corrosion monitoring and mitigation tools for the construction, commissioning, and operation of the pipelines are chosen based on good engineering practices and operational experience and may include corrosion inhibitors, biocides, oxygen scavengers, corrosion weight loss coupons, electrical resistance probes, non-destructive examination inspection techniques, smart pigs, visual inspections, Kinley caliper surveys, monitoring of process flow conditions, and bioprobes.

External Corrosion: Piping associated with process operations at the Point Thomson facility will not be below grade. Transfers from a tank barge to the diesel storage tank will be accomplished using a fuel transfer hose.

The sales condensate pipeline will be welded and corrosion protected at road crossings as required by 18 AAC 75.080(b)(1)(A). The sales condensate pipeline will be lowered, enclosed in another pipe or culvert, and covered by gravel at the road crossings. There will also be a diesel pipeline from the diesel tank area to the generator and a gas pipeline from well area on the CWP to fuel the turbines. These pipe segments will also be below grade in vaults and corrosion protected. Cased and vaulted piping segments will not be readily accessible for external inspection; therefore, cased and vaulted piping inspections will not be conducted seasonally.

Corrosion Data

Point Thomson will use corrosion monitoring and inspection data to manage the corrosion control program. The corrosion monitoring program may generate data from corrosion probes, coupons and/or inspection. Each type of data has its benefits and limitations; therefore the data from corrosion probes, coupons and inspection will be viewed as complementary and used in concert in managing the corrosion control program. These monitoring techniques, together with process data, will allow a clear picture to be formed of corrosion activity in the equipment. All process equipment will be covered by the corrosion monitoring program.

The data from the corrosion control, monitoring, and inspection programs will be handled with an electronic database for analysis of current and historical data. In addition to periodic reviews of current data, more in-depth reviews will be conducted looking for broader changes or trends.

Corrosion Inspection Activities

The export pipeline is designed to allow internal inspection by the use of wall thickness measurement pigs, 3-Dimensional geometry pigs and mechanical caliper pigs. The frequency of inspection is currently undetermined, but will be developed to be consistent with the overall corrosion management program.

Buried or Insulated Transfer Piping Outside of Secondary Containment Used to Transfer Oil to or from Docks or Vessels

The facility will not have buried or insulated transfer piping that transfers oil to or from docks or vessels at Point Thomson.

Aboveground Transfer Piping to Transfer Oil from Docks or Vessels

There will not be aboveground piping that transfers oil from docks or vessels at Point Thomson.

Abandonment

Any piping removed from service for more than one year will be drained, identified as to origin, marked "Out of Service," and capped or blind flanged.

Aboveground Piping and Valves

Aboveground piping and valves will be inspected visually as outlined in Section 2.5.5.

Piping Supports

The overland condensate export pipeline and supports will be designed to resist seismic loads, and they will be seismically stable. The overland pipeline supports will have all-steel structural components. This is the common design practice used for other overland pipeline supports on Alaska's North Slope, where experience shows that corrosion of the steel components does not readily occur.

Protection of Piping from Vehicles

Any aboveground transfer lines near traffic areas will be protected from damage and marked with reflectors.

2.1.10 Oil Storage Tanks [18 AAC 75.065]

Appendix B contains ADEC regulated stationary oil storage tank data for tanks with capacities greater than 10,000 gallons. Appendix B also lists information on tanks that are regulated by the EPA and have capacities less than 10,000 gallons.

There will be four 12,500-bbl diesel tanks at Point Thomson. The diesel tank facilities will store and dispense diesel fuel for construction, drilling, and operational requirements. The diesel tanks will be sized to meet the fuel needs for drilling, construction, and operations when the ice road and barge routes cannot be used to deliver fuel. The 12,500-bbl diesel tanks are designed to API 650. The tanks will have leak detection systems and an instrumentation and controls system adequate to safeguard the tank storage, loading, and dispensing operations.

The portable storage tanks at Point Thomson will be used for temporary diesel storage. The inventory of portable tanks may vary over time, as facility needs change. Interim portable oil storage tanks, defined as temporary tanks borrowed from other fields or rented from third parties, may be required to support drilling, production, maintenance, or response operations. Oil storage tanks will comply with API Standards 650, 653, and API 12, and state regulatory requirements, where applicable. The ExxonMobil office at Point Thomson will maintain the current inventory for portable tanks in use at the facility.

Inspection and maintenance records for the ExxonMobil-owned permanent and portable tanks will be maintained by ExxonMobil's Corrosion, Inspection, and Chemicals (CIC) Specialist. Before interim tankage is placed into service, CIC will review the tank records to ensure compliance with state regulations, and API 650, 653, and API 12 standards, where applicable. Subsequent inspection, modification, and maintenance records will be kept as long as the tankage remains in service.

2.1.11 Secondary Containment Areas [18 AAC 75.075]

Oil Storage Tanks

Appendix B includes secondary containment descriptions, including volume, and the year the tank is anticipated to be constructed and installed. The appendix also identifies tank loading/unloading areas and describes secondary containment in these areas.

Stationary oil storage tanks will be double-wall and double-bottom construction or will be located within a secondary containment area with the capacity of 110 percent of the largest tank's volume, unless they have been granted a waiver by ADEC. Diked secondary containment areas will be constructed of bermed/diked retaining walls. The diked containment areas will also be lined with impermeable materials resistant to damage and weather conditions. These areas will be kept free of debris, including accumulated rainwater, and inspected as detailed in Section 2.5.5. Before accumulated snow and water are vacuumed from secondary containment, the areas will be inspected for a sheen. A written record of each drainage/dewatering event will be maintained on a Fluid Transfer Checklist or a North Slope Manifest, which will be completed prior to offloading fluids to the CPF. Fluids offloaded into the plant will be subject to hydrocarbon recovery and water injection. Fluid

Transfer Checklists and North Slope Manifests will be kept on file at the Point Thomson facility. Tanks with double-walls and double-bottoms will be provided with supplemental instrumentation and a means of draining the interstices.

Portable oil storage tanks with a capacity greater than 10,000 gallons will be double-wall and double-bottom construction or will have secondary containment with a capacity equal to at least 110 percent of the tank capacity whenever they are in service. At the jobsite, the tanks will be placed into temporary containment constructed of impermeable liner supported by timbers.

Loading/Unloading Areas

The capacity of the planned loading/unloading secondary containment area is 14,000 gallons. A typical offloading of diesel would be to the local 4,448-gallon mobile fuel truck for transporting to other equipment operating throughout the Point Thomson field. The volume of the largest tank truck compartment using the area will be 12,180 gallons. The only other offloading would be to a well service truck with a volume of approximately 3,000 gallons. Overfill protection devices will be tested before each transfer operation, or monthly, whichever is less frequent.

2.2 DISCHARGE HISTORY [18 AAC 75.425(e)(2)(B)]

The Point Thomson facility is not yet constructed and has no discharge history.

As described in Section 2.1.1, OIMS ensures continuous improvement in environmental performance. When a discharge does occur, the cause, effect, and corrective and preventive measures will be recorded, studied, and become a part of OIMS. From OIMS analysis, training and/or maintenance programs will be implemented to prevent future spills.

2.3 POTENTIAL DISCHARGE ANALYSIS [18 AAC 75.425(e)(2)(C)]

Table 2-1 identifies potential spill sources, the types of failures that may occur, estimates of spill sizes, and appropriate secondary containment measures.

2.4 CONDITIONS INCREASING RISK OF DISCHARGE [18 AAC 75.425(e)(2)(D)]

Conditions specific to ExxonMobil North Slope operations that potentially increase the risk of discharge, and actions taken to eliminate or minimize identified risks are summarized below.

- **High Temperature:** Heat may cause gases to expand, increasing the likelihood of discharge. North Slope facilities are engineered to accommodate temperature fluctuations.
- **Low Temperature:** Low temperature could cause some materials to become brittle or to contract differentially, increasing the risk of equipment failure. Fluids in pipes and tanks could freeze or become gelatinous, potentially rupturing pipes or tanks, as well as reducing the ability to pump fluids. Valves or other equipment could ice over or otherwise freeze, not allowing them to operate as necessary to prevent discharges. North Slope facilities are specifically engineered to accommodate Arctic conditions.

**TABLE 2-1
ANALYSES OF POTENTIAL DISCHARGES**

TYPE	CAUSE	PRODUCT	SIZE	DURATION	ACTIONS TAKEN TO PREVENT POTENTIAL DISCHARGE
Diesel transfer to tank truck	Tank overfill	Diesel	30 gallons	30 seconds	Transfer procedures
Diesel transfer from barge to diesel tank	Hose rupture	Diesel	440 to 880 gallons	1 to 2 minutes	Transfer procedures; hose watch
Diesel tank	Tank rupture	Diesel	2,733 bbl	Instant	Double-wall; engineering design; tank inspection program
Pipeline	Leak below detection limits	Condensate	428 bbl	7 days	Engineering design; redundant leak detection systems; smart pig analysis/corrosion monitoring
Blowout	Uncontrolled flow from wellbore	Condensate	723 bbl	15 days	Blowout prevention equipment; voluntary ignition of the source

- **High Pressure:** The Thomson Sand reservoir is higher pressure than other North Slope fields. The drilling program will incorporate the use of at least two safety barriers at all times, the drilling mud and BOPE. Specific BOPE is chosen based on well design and the expected pressure and temperature. Likewise, facility design includes constructing pipelines, vessels and valves rated for high pressure.
- **Weather Conditions:** Icy roads, whiteout conditions, and cold snaps present obvious hazards to field operations. Security's strict enforcement of vehicle safety, speed limits, and the posting of warning signs assist in minimizing the potential for vehicular accidents that may result in a spill. In addition, North Slope facilities are engineered to withstand Arctic conditions.
- **Traffic Patterns:** Changes in traffic patterns may increase the risk of vehicles colliding with well lines. Security's strict enforcement of vehicle safety, speed limits, and the posting of warning signs or traffic cones will help to minimize the potential for vehicular accidents that may result in a spill.
- **High Water/Ice:** High water and/or ice during break-up could increase the risk of discharge over river crossings. Vertical support members (VSMs) will elevate the pipeline above the water, and stream crossings will be designed to accommodate high break-up flows.
- **Age of Facilities:** As the PTU field ages, the discharge potential increases. To minimize spills related to aging facilities, ExxonMobil will use a computerized preventive maintenance system, have a corrosion program, perform valve inspections in accordance with AOGCC regulations, have a leak detection system, and conduct regular visual inspections.

2.5 DISCHARGE DETECTION [18 AAC 75.425(e)(2)(E)]

2.5.1 Drilling Operations

Each drilling rig will have a system of controls, monitors, and procedures to assist in the early detection of potential discharges. For both downhole and surface operations, these detection systems will include automated monitoring devices as well as standard operating procedures (SOPs) governing the handling and containment of fluids.

During downhole operations, much of the discharge detection effort will center on well control with an emphasis on detecting wellbore influx (kicks) early. The primary control to prevent a discharge associated with a kick is the density of the drilling fluid in the wellbore. The fluid density and other critical parameters will be monitored closely 24 hours a day by drilling fluid specialists and trained members of the rig crew. The well control equipment will include several independent kick detection devices. The SOP dictates that these systems are monitored 24 hours a day by rig crew members trained in well control to further ensure the timely recognition of and defense against potential spill events.

Kick detection systems will use automated equipment, and visual and/or manual detection in combination with policies and procedures governing the handling and containment of fluids. Rig pit systems will be equipped with pit volume totalizers (PVT) that constantly monitor pit-volume gain and loss. Unexpected gain or loss of drilling fluid will immediately alert rig personnel, who will initiate countermeasures to ensure well control is maintained.

All rig surface support systems will be inspected twice during each 24-hour day for fuel or oil discharges and/or potential leaks. Fluid transfers associated with drilling operations will be carefully planned and monitored using ExxonMobil fluid transfer guidelines. Strict adherence to these procedures will ensure immediate detection of spills associated with fluid transfer operations and significantly reduce the probability of occurrence.

2.5.2 Automated Methods for Processes and Tanks

Automated control systems and visual monitoring of instrument/control panels at the CPF will be used to control flow rates as well as detect potential discharges and process upsets. The control systems and instrumentation will consist of a process control system, as well as a simultaneous independent Safety Instrumented System (SIS/ESD). This redundancy will limit the scope of any single failure. An ESD can be initiated by process conditions outside set limits, or manually by operators at the instrument/control panels. Process conditions that will trigger the SIS/ESD system include either an excess or loss of pressure in a pipeline or equipment malfunction within a production facility. The SIS/ESD system will be provided and maintained for the explicit purpose of stopping hydrocarbon flow when these pipeline or facility problems are encountered. A cascading shutdown system will be used to shut in wells and pipelines prior to relieving pressure on vessels or other process systems at the production facilities. The facilities will also be inspected from the ground on a routine basis for detection of spills and equipment malfunction.

The Integrated Control and Safety System (ICSS) will monitor and operate the oil production wells, process facilities, and pipelines. The ICSS will involve microprocessor-based distributed systems that employ three major categories of digital instrumentation and control, integrated into a single integrated system. The three categories are the DCS, SCADA, and the SIS. The combined system will interface with the communications network.

Operators will control the system through computers. The system will be reliable, as the communications network will be completely redundant. Each of the three planned operator consoles is a separate entity, and critical process loops are under redundant control.

At the process center, control systems and visual monitoring of instrumentation will be used to control injection flow rates, pressures, and distribution. Pressure-relieving devices will be installed on all pressurized units. The facilities will be visually inspected on a routine basis to check for spills and equipment malfunctions.

Production facilities will be continuously monitored with a microprocessor-based DCS. Incoming alarms from the facilities, wells, or pipelines will be documented by date and time. This system capability will allow for the quick tracking of cause-and-effect relationships during upset conditions. In addition, a manually operated, fully automated shutdown system will be available if the computerized system is down and the facilities experience excess pressure or malfunction during production. The production wells will automatically shut in when low producing pressures are detected.

When an emergency requiring shutdown of one or all of the facilities occurs, the SIS will be used. The SIS will be integrated with the DCS. The SIS processor can accept operator commands and transfer status/alarm information to the main operator's console. Redundant SIS systems will provide maximum system integrity for performance of ESD functions.

Lines connecting condensate-producing wells will be equipped with low-pressure transmitters to isolate producing wells in the event of a line rupture. If the operating pressure in the line drops below 150 psi, the line will shut in. Small leaks that would not activate the low-pressure switch would be identified by operations personnel performing routine checks. Given that production fluids are mostly gas and water, with smaller amounts of oil, leaks would involve relatively large amounts of visible steam and gas, which are easily identified by both sight and sound. If small leaks occur, manual steps will be taken immediately by operational personnel to isolate the leak.

The 12,500-bbl diesel oil storage tanks will be fitted with a liquid level transmitter for control room monitoring.

2.5.3 Pipelines

Point Thomson Condensate Export Pipeline

The condensate export pipeline will include state-of-the-art leak detection instrumentation which will be connected to the process facilities control room. The daily operation of the pipeline will be monitored on a continuous basis. Operating personnel will be provided real-time information on pipeline status. For correct operation of the system, regular checks will be conducted on the equipment employed, including the hardware and associated software. In addition, weekly aerial surveillance of the pipeline will be performed.

Monitoring pipeline conditions is also an important part of leak detection. Information on the wall thickness will be obtained by pigging devices that run at predetermined time intervals. The pipeline will be capable of accommodating inspection pigs to obtain information to provide early warning of potential leak points or pipeline deformation. The inspection pig launchers and receivers will be located at each end of the pipeline. Systematic pig runs will allow operators to monitor trends, which will help forecast maintenance work. After reviewing the results from the inspections runs, preventive and/or corrective actions will be identified

and implemented, if required. To ensure the correct operation of the system, regular checks will be conducted on the equipment, including the hardware and associated software.

Export pipeline inspection, maintenance, and repair will be performed in accordance with DOT regulations and the right-of-way lease issued by ADNR. Records will be maintained on site.

Point Thomson Gathering Lines

The primary leak detection method for the gathering lines will be visual inspection. In addition to visual inspection, each gathering line will have pressure transmitters to detect low line pressure caused by a catastrophic line rupture. The pressure transmitters will interact with the control system to indicate closure of the inlet valves of each well and outlet shutdown valves upon detection of line pressure outside the acceptable range.

2.5.4 Fire and Gas Alarm System (Process Areas)

The Fire Alarm System is comprised of both a network of individual fire control panels in the CPF and some fire control panels which are not in the network (due to distance limitations). Each fire control panel receives signals from flame, heat, and smoke detectors and activates notification alarms. Gas detectors send their analog signals to the SIS. Upon low- and high-gas level determination by SIS, digital signals are hardwired to the Fire Alarm System which activates the notification alarms.

The Fire Alarm System activates the fire suppression system and notification alarms in response to a fire or low/high gas detection. The fire and gas detection system works in conjunction with the safety shutdown system to provide executive action as required.

All fire and gas system points are transmitted on redundant data links to the PCS. The PCS, in the constantly attended CCR, will monitor, display, alarm, and historize all fire and gas system point status, alarms, and faults. In addition, a dedicated Fire Alarm System Annunciator and a Priority 1 Annunciator will display alarms in the CCR. The Fire Alarm System also historizes fire-system events.

The fire and gas systems may be bypassed to enable maintenance testing. The bypass condition will be alarmed and historized at the CCR and remain active until the system is restored to normal. If a fire or gas condition is detected while in bypass, alarms will activate, but the automatic fire suppression system and executive actions will not respond. Operations personnel would be required to initiate response to the event.

2.5.5 Inspections

General Drillsite, Pad, Flowline, Gathering Lines, Oil Transmission Line, and Facility Inspections

Detection of liquid hydrocarbon discharge from multi-phase flowlines, the condensate export line, permanent and portable tanks, drillsite equipment, and facilities in general will be supported by visual inspections (surveillance). Visual field inspection forms will be completed by operations and security personnel on a daily basis and by other groups, as dictated by their activities and corresponding procedures.

Routine visual inspections of drillsites, pads, and facilities will be significant and productive. The North Slope operators, in a continuing effort to enhance field-wide best management practices (BMP), have developed field inspection guidelines. Table 2-2 outlines the specific requirements for visual surveillance and the groups responsible for performing these surveillances. The ACS Technician is available to help with reporting and/or cleanup activities.

Pad and facility operators will regularly conduct inspections and be trained to look for the following:

- General liner use,
- Fuel tanks (location, liner use, secondary containment),
- Barrels (location, leaders, or lying down),
- Overturned containers,
- Loads secured,
- Leaking equipment,
- Spills or spots,
- Gravel pushed off the road or pads,
- Off-road vehicle travel,
- Animal situations, and
- Equipment refueling.

Multi-phase flowlines, which will move produced fluids from the wellhead to the drillsite manifold, and multi-phase gathering lines, which will move produced fluids from the drillsite manifold to the production facility, will usually be inspected at least monthly, as required by 18 AAC 75.080.

More specifically, the following groups will support the visual inspection process:

- **Security** will contact ExxonMobil's site supervisor when it observes a leak or spill. Security will also complete pipeline inspection forms and contact the spill reporting telephone line to report observed oil or gas discharges during planned inspections of the condensate export pipeline, and upon request during inspections of select gathering lines.
- **Employees** will be responsible for conducting visual inspections of their work areas and reporting spills and leaks to their supervisors.
- **Contractors** will be responsible for visual inspections of work areas and cleaning up spills they may cause.
- **Environmental staff** at Point Thomson will support and verify spill response and clean-up efforts.

2.6 RATIONALE FOR CLAIMED PREVENTION CREDITS [18 AAC 75.425(e)(2)(F)]

ExxonMobil is claiming prevention credits at Point Thomson for the RPS volumes for the well blowout, diesel tank rupture, and export pipeline condensate spill response scenarios.

**TABLE 2-2
VISUAL SURVEILLANCE SCHEDULE**

INSPECTION	RESPONSIBLE POSITION	REGULATING AGENCY	INSPECTION REQUIREMENTS	FREQUENCY REQUIREMENT	REGULATORY CITATION	RECORD KEEPING
Oil Storage Tanks	Facility Personnel	EPA	Visual inspection of tanks, piping, and drain valve	Regular	112.8(c)(6), 112.8(d)(4), 112.9(d)(1) and Appendix F, 1.8.1.1	Weekly reading sheet filed in Document Control
		ADEC	Visual inspection of external condition of storage tanks	Monthly	18 AAC 75.065, following API 653 Sections 4.3.1.1 and 4.3.1.2	Visual field inspection form, maintain records for service life of tanks
Secondary Containment Areas for Oil Storage Tanks where applicable	Facility Personnel	ADEC	Visual inspection for oil leaks or spills	Daily at staffed facilities, monthly at unstaffed facilities	18 AAC 75.075(a)(3)(A)	Visual field inspection form
		EPA	Visual inspection	Regular	40 CFR 112 Appendix F, 1.8.1.3	Visual field inspection form, maintain records for 5 years
Crude Oil Transmission Line, Aboveground Flowlines, Multi-Phase Gathering Lines, and Facility Piping and Valves	Facility and Field Personnel and Security	ADEC	Visual inspection of piping and valves	Monthly or during routine operations, if more frequent	18 AAC 75.080(f)	Daily field shift log
Wellhouses and Pads	Field Production Personnel	ADEC	Visual inspection of wellhouses, well cellars, process modules, and well lines	Daily	18 AAC 75.080(f)	Wells daily review sheet filed in Document Control
Condensate Export Pipeline	Security	DOT	Surveillance of condensate export pipeline right-of-way	26 times a year, not to exceed 3 weeks between surveillances	49 CFR 195.412(a)	DOT Pipeline Inspection Checklist Report
	Aviation	ADEC	Aerial surveillance of 16 miles inaccessible to on-the-ground inspection	Weekly, unless precluded by safety and weather conditions	18 AAC 75.055(a)(3)	Aviation log
	Facility and Field Personnel and Security	ADEC	Visual inspection of piping and valves	Monthly or during routine operations, if more frequent	18 AAC 75.080(f)	Daily field shift log

2.6.1 Well Blowout RPS

The following prevention credits are claimed for the well blowout RPS, in accordance with 18 AAC 75.434(c), Response Planning Standards for Exploration or Production Facilities, and/or based on other prevention measures in place at Point Thomson.

- 5 percent prevention credit for drug/alcohol testing [18 AAC 75.434(c)(1)],
- 5 percent prevention credit for well control training for tool pushers and drillers [18 AAC 75.434(c)(2)],
- 5 percent prevention credit for real-time bottom-hole pressure measurements [18 AAC 75.434(c)(4)],
- 5 percent prevention credit for a computer-aided management system for inspection, maintenance, and repair [18 AAC 75.434(c)(5)],
- 5 percent prevention credit for formal safety analysis [18 AAC 75.434(c)(6)],
- 5 percent prevention credit for SCSSVs for emergency shutdown [18 AAC 75.434(c)(7)],
- 10 percent prevention credit for the Operations Integrity Management System,
- 5 percent prevention credit for assurance of well tubular integrity,
- 5 percent prevention credit for an on-site mud system,
- 5 percent prevention credit for overbalanced drilling confirmation technique, and
- 10 percent prevention credit for a five-preventer BOP stack.

Drug and Alcohol Testing

ExxonMobil will have a substance abuse program in place at Point Thomson (Section 2.1.2) and will provide a drug-free workplace for employees and contractors. Employees and contractors will adhere to ExxonMobil drug and alcohol testing procedures and policies, and contract-company drug and alcohol policies will be required to be at least as stringent as ExxonMobil policies. These policies include random drug screening, testing for cause, and search and seizure. Any employee that does not comply with these policies will be subject to disciplinary action up to and including termination of employment. Approximately 25 percent of ExxonMobil Point Thomson employees will be randomly screened on an annual basis.

Well Control Training

ExxonMobil will require certified well control training for Point Thomson drilling supervisors, superintendents, engineers, drillers and tool pushers. The training meets the intent of 18 AAC 75.434(c)(2) and AOGCC 20 AAC 25.527 as an operations training program with certification by a professional organization. The curricula consist of training in blowout prevention technology and well control, and result in certification of participants. Before startup, the Point Thomson rig team will have also received TRUE, which focuses on increasing knowledge and awareness to prevent and deal with potential hazards. Well control training, including TRUE, is described in Section 2.1.7.

TRUE, which involves a multifunctional team made of rig contractor, service company, and operator personnel, will establish a team concept and a team approach to identifying and solving problems. The training will be based specifically on Point Thomson development wells and include practices for high-pressure drilling operations. Special emphasis will be placed on abnormal pressure detection and well control. The goal of TRUE is to provide site-specific solutions to potential problems before they occur. Potential hazards will be defined by the team, including well control and lost returns, and action plans will be developed to identify roles and responsibilities, warning signs, how to react to an event, and lines of communication.

Bottom-Hole Pressure Measurements

ExxonMobil will measure bottom-hole pressure while drilling, with computer-assisted analysis of drilling fluids circulation using a professional organization standard or recommended practice [18 AAC 75.434(c)(4)]. ExxonMobil will use state-of-the-art technology to enhance drilling performance and mitigate risk. Several of the technologies are known as logging while drilling (LWD) and pressure while drilling (PWD). The LWD system enhances early detection of over-pressured intervals or possible lost circulation zones. The PWD directly monitors bottom-hole pressures, enabling the operator to maintain sufficient overbalance without compromising the formation integrity. Early detection of over pressure and maintaining sufficient overbalance while drilling will minimize any chance of incurring a well control event.

As described in Section 2.1.7, ExxonMobil has developed an IP3 Team that will analyze seismic data, well data from exploration wells, and geologic models to develop a detailed understanding of the reservoir. The use of advanced technology will enable accurate prediction of formation behavior as wells are drilled and allow the engineer to plan a well that minimizes the risk of a well control incident.

Real-time data will be presented on a monitor at the driller's console, as well as in Anchorage and Houston. The system will also incorporate full-time monitoring of the circulation and pit systems. It is an improvement on an industry recommended practice that only monitors mud weight in a mud pit before pumping downhole.

Computer-Aided Management of Inspection, Maintenance, and Repair

ExxonMobil will use a computerized preventive maintenance program to help manage inspection, maintenance, and repair of the drilling rig and associated equipment. The contractor's preventive program will be reviewed, gap analysis will be performed, and an agreed-upon, computer-aided system will be followed. The contractor will have the responsibility to maintain the program, while the operator closely monitors the program.

Formal Safety Analysis

ExxonMobil has a formal safety analysis program to manage safety, health, and environmental risks. Elements of the program include incident analysis, emergency preparedness, and risk assessment and management. Effective incident investigations at Point Thomson will provide the opportunity to learn from reported incidents and to take corrective action and prevent reoccurrence. Emergency preparedness will ensure that, in the event of an incident, all necessary actions are taken to protect the environment, employees, and property. Comprehensive risk assessment will be used to reduce risks and mitigate the consequences of incidents by providing essential information for decision-making. The formal safety analysis program is conducted under OIMS, which is further described below and in Section 2.1.1.

Surface-Controlled Subsurface Safety Valves

The Point Thomson drilling program includes the use of BOP and monitoring techniques that exceed regulatory requirements. As an added safety measure, SCSSVs will be in each tubing string to automatically shut in the well if necessary. The ESD system allows for complete surface isolation from several remote locations and is further described in Section 2.1.7.

Operations Integrity Management System (OIMS)

ExxonMobil is committed to conducting business in a manner that is compatible with the environmental and economic needs of communities in which they operate and that protects the safety and health of employees, those involved in operations, customers, and the public. These commitments are documented in ExxonMobil's safety, health, and environmental policies. ExxonMobil's OIMS provides the strategic direction for meeting that commitment, and consists of 11 elements, as shown on Figure 2-1, each of which includes an underlying principle and a set of expectations to be met in the design, construction, and operations of facilities. The well-established OIMS program ensures that all aspects of operations are evaluated for continuous improvement.

OIMS drilling requirements provide numerous detailed and explicit guidelines for planning and implementing safe drilling operations. For example, Element 3 requires ExxonMobil to meet or exceed regulatory requirements and embody responsible requirements where regulations do not exist in design standards. A risk assessment was performed on well control, and in order to manage the risk at Point Thomson, a fifth preventer was incorporated into the BOP arrangement (as described below in this section) and the need to properly train personnel for high-pressure drilling was recognized. Element 5 (Personnel and Training) is used to develop the necessary training programs for the drilling team. OIMS is used extensively throughout ExxonMobil's worldwide organization to ensure risks are properly evaluated and that systems are in place to manage the risk.

Well Tubular Integrity

ExxonMobil's casing and cementing program is designed to provide safe operating conditions for the total measured well depth. Metal-to-metal seals, which are superior to the customary elastomeric seals, will be used in the wellhead for maximum seal integrity. ExxonMobil will test and qualify tubing and casing connections for seal integrity. Casing and tubular connections will be analyzed with finite element analysis and prequalified through physical testing. In addition, the technical specifications for metallurgical properties will be confirmed by testing.

ExxonMobil will use a production liner instead of a full casing string to eliminate the possibility of annular gas flow to the surface. Additionally, cement slurries will be designed to avoid annular gas flow. ExxonMobil's tubing and production casing design policy for this reservoir includes a 12.5 percent collapse safety factor for producing wells, a 25 percent burst-safety factor, and 37.5 percent burst safety factor for surface and protective casing for injection wells.

On-Site Mud System

ExxonMobil will construct a complete mud plant and storage facility to support drilling operations at Point Thomson. The infield mud plant will provide ample capacity beyond the wellsite reserve. This plant will augment the rig systems for both mud mixing and storage

during any period when mud requirements are critical. Due to the remote nature of Point Thomson, high-pressure fluid-pumping equipment must reside within the field, and redundant units will be available for immediate use if a well control incident occurs. The mud system is further described in Section 2.1.7.

Overbalanced Drilling Confirmation Technique

ExxonMobil has developed a confirmation technique called the “10/10/10 Test” to help evaluate whether an overbalanced situation exists in the wellbore. This technique may be applied at any point in the well, but will be most valuable when performed in the shale intervals overlying the productive zone (the Thomson Sand). At this point in the well, one necessary component for a kick is missing: the permeable formation. Testing using the 10/10/10 Test can provide accurate and early diagnostics of the formation pressure before the potential kick interval is reached.

The 10/10/10 Test involves circulating the well for 10 minutes to establish background gas, discontinuing mud circulation for 10 minutes to reduce equivalent circulating density (ECD), and circulating the wellbore for an additional 10 minutes. Mud is then circulated from the bottom of the well, without further drilling, to the surface. Gas concentrations are measured and an evaluation is done to determine whether the overbalance is sufficient.

Five-Preventer BOP Stack

A fifth preventer was incorporated into the BOP stack arrangement in order to manage the risk at Point Thomson. A BOP stack with four sets of rams and one annular preventer will be used to drill below surface casing, providing one more preventer than required by AOGCC regulations. The rams and annular preventer will all be rated to 10,000 psi working pressure. This arrangement allows two preventers to close on the casing and liners, and in the case of liners, permits two ram-type and one annular preventer to be used on the drill-pipe running-string without having to stop and change-out rams. The extra ram will also provide added redundancy.

2.6.2 Tank Rupture RPS

Prevention credits are claimed for the diesel tank rupture RPS volume in accordance with 18 AAC 75.432 (d), Response Planning Standards for Oil Terminal Facilities, as follows:

- 5 percent prevention credit for drug/alcohol testing [18 AAC 75.432(d)(1)],
- 5 percent prevention credit for operations training and licensing program [18 AAC 75.432(d)(2)],
- 5 percent prevention credit for on-line leak detection systems [18 AAC 75.432(d)(3)],
- 60 percent prevention credit for secondary containment (provided by double-wall tank construction with leak detection) [18 AAC 75.432(d)(4)],
- 15 percent prevention credit for fail-safe valves on piping systems [18 AAC 75.432(d)(5)(B)], and
- 25 percent adjust for double bottoms with leak detection [18 AAC 75.432(d)(5)(C)].

Drug and Alcohol Testing

ExxonMobil has a substance abuse program in place, which includes testing as described briefly above under Well Blowout RPS and more thoroughly in Section 2.1.2.

Operations Training and Licensing Program

ExxonMobil's training for bulk tank-farm operators meets the intent of 18 AAC 75.434 (2)(C)(2), as an operations training program with certification by a professional organization. The curricula consist of training in hazard identification, operating procedures, safe work practices, emergency response and control procedures, management of change, pre-startup safety, incident investigation, and contractor safety and result in certification of participants. Fuel transfer procedures have been developed and implemented for North Slope operations and adopted by ExxonMobil. The *North Slope Fluid Transfer Guidelines* (Appendix A) describe practices for safe, responsible transfers of diesel that will be adhered to during Point Thomson operations.

On-Line Leak Detection Systems

The diesel tanks will have leak detection systems and an instrumentation and controls system that are adequate to safeguard the tank storage, loading, and dispensing operations. The leak detection system is further described in Sections 2.1, 2.5.2 and 4.6

Secondary Containment

ExxonMobil claims a 60 percent prevention credit under 18 AAC 75.432(d)(4) for secondary containment. The tanks will be constructed with double walls and double bottoms and designed with automated leak detection and monitoring.

Fail-Safe Valves on Piping Systems

Automatic valves will be provided on the diesel storage tank piping systems as described in Section 4.2.3. Automatic valves provide the most effective means to stop the flow of oil into tanks whose levels are constantly changing.

Double-Bottom Tanks with Leak Detection

ExxonMobil claims a 25 percent prevention credit under 18 AAC 75.432(d)(5)(C) for double bottoms with leak detection.

2.6.3 Condensate Export Pipeline RPS

The following prevention credits are claimed for the RPS volume for the condensate export pipeline spill scenario in accordance with 18 AAC 75.436(c), Response Planning Standards for Crude Oil Pipelines.

- 5 percent prevention credit for drug/alcohol testing [18 AAC 75.436(c)(1)],
- 5 percent prevention credit for on-line leak detection systems [18 AAC 75.436(c)(3)], and
- 15 percent prevention credit for instrumented in-line cleaning and diagnostic equipment, also known as smart pigs [18 AAC 75.436(c)(4)(B)].

Drug and Alcohol Testing

ExxonMobil has a substance abuse program in place, which includes testing as described briefly above under Well Blowout RPS and more thoroughly in Section 2.1.2.

On-line Leak Detection Systems

The leak detection systems to be used at Point Thomson are described in Sections 2.1.8, 2.5.3, and 4.7.

Instrumented In-line Cleaning and Diagnostic Equipment (Smart Pigs)

The condensate export pipeline will use smart pigs for diagnostics and corrosion control, as described in Section 2.1.8.

2.7 COMPLIANCE SCHEDULE AND WAIVERS [18 AAC 75.425(e)(2)(G)]

Not applicable.

TABLE OF CONTENTS FOR SECTION 2

2. PREVENTION PLAN [18 AAC 75.425(e)(2)].....2-1

2.1 PREVENTION, INSPECTION, AND MAINTENANCE PROGRAMS [18 AAC 75.425(e)(2)(A)] 2-1

2.1.1 Prevention Training Programs [18 AAC 75.007(d)] 2-1

2.1.2 Substance Abuse Programs [18 AAC 75.007(e)] 2-3

2.1.3 Medical Monitoring [18 AAC 75.007(e)] 2-4

2.1.4 Security Programs [18 AAC 75.007(f)]..... 2-5

2.1.5 Fuel Transfer Procedures [18 AAC 75.025]..... 2-5

2.1.6 Operating Requirements for Exploration and Production Facilities [18 AAC 75.045] 2-7

2.1.7 Blowout Control [18 AAC 75.425(e)(1)(F)(iii)]..... 2-8

2.1.8 Leak Detection, Monitoring, and Operating Requirements for Crude Oil Transmission Pipelines [18 AAC 75.055] 2-14

2.1.9 Facility Piping Requirements for Oil Terminal, Crude Oil Transmission Pipeline, Exploration, and Production Facilities [18 AAC 75.080] 2-15

2.1.10 Oil Storage Tanks [18 AAC 75.065]..... 2-18

2.1.11 Secondary Containment Areas [18 AAC 75.075] 2-18

2.2 DISCHARGE HISTORY [18 AAC 75.425(e)(2)(B)] 2-19

2.3 POTENTIAL DISCHARGE ANALYSIS [18 AAC 75.425(e)(2)(C)] 2-19

2.4 CONDITIONS INCREASING RISK OF DISCHARGE [18 AAC 75.425(e)(2)(D)]..... 2-19

2.5 DISCHARGE DETECTION [18 AAC 75.425(e)(2)(E)]..... 2-21

2.5.1 Drilling Operations..... 2-21

2.5.2 Automated Methods for Processes and Tanks 2-21

2.5.3 Pipelines..... 2-22

2.5.4 Fire and Gas Alarm System (Process Areas) 2-23

2.5.5 Inspections 2-23

2.6 RATIONALE FOR CLAIMED PREVENTION CREDITS [18 AAC 75.425(e)(2)(F)]..... 2-24

2.6.1 Well Blowout RPS 2-26

2.6.2 Tank Rupture RPS 2-29

2.6.3 Condensate Export Pipeline RPS 2-30

2.7 COMPLIANCE SCHEDULE AND WAIVERS [18 AAC 75.425(e)(2)(G)]..... 2-31

LIST OF FIGURES

2-1 Operational Integrity Management System Elements 2-2

2-2 Technology Integration With IP3..... 2-10

2-3 The Relationship Between Corrosion Control and Monitoring Programs 2-16

LIST OF TABLES

2-1 Analyses of Potential Discharges 2-20

2-2 Visual Surveillance Schedule 2-25

3. SUPPLEMENTAL INFORMATION [18 AAC 75.425(e)(3)]

3.1 FACILITY DESCRIPTION AND OPERATIONAL OVERVIEW [18 AAC 75.425(e)(3)(A)]

3.1.1 Facility Ownership, Location, and General Description

The ownership of the Point Thomson Gas Cycling Project is as follows:

- ExxonMobil 36%
- BP Exploration (Alaska) Inc. 31%
- ChevronTexaco 25%
- ConocoPhillips 5%

Twenty other owners have a combined working interest of 3 percent. ExxonMobil is the operator of the Point Thomson Unit.

The summary of the condensate and reservoir characteristics for the Thomson Sand reservoir is presented in Table 3-1.

**TABLE 3-1
CONDENSATE AND RESERVOIR CHARACTERISTICS**

PRODUCTION WELLS AT RESERVOIR DEPTH	VALUE
Avg. Depth (subsea)	12,750 feet
Avg. Temperature	230°F
Avg. Initial Pressure	10,250 psi
Avg. Production per Well	100-150 mmscf/d
Avg. Gas-to-Oil Ratio	17,250 scf/bbl (equates to 58 barrels per million standard cubic feet gas [BPMSCF])
CONDENSATE	
Percentage water (sales)	Basic sediment and water (BS&W) <0.35%
API gravity	39
Pour point °F	Approximately 1°F ¹
Percentage sulfur	0%

¹ Pour point will be re-determined after initial well testing.

Point Thomson is located on the North Slope of Alaska immediately west of the Staines River. The Thomson Sand reservoir, the development objective for Point Thomson, is a deep (-12,750 feet sub-sea), high-pressure gas condensate reservoir that was discovered in 1977. It is estimated to contain more than 8 trillion cubic feet of gas in-place and approximately 400 million barrels of recoverable condensate. The reservoir lies approximately 60 miles east of Prudhoe Bay, approximately 22 miles from the nearest infrastructure at Badami. Although most of the reserves are offshore, they will be produced from onshore well pads along the coastline.

The Point Thomson owners are proposing to develop this reservoir as a “gas cycling” project. A gathering pipeline system will collect production from well pads located on the eastern and western margins of the reservoir and deliver the three-phase stream to the CPF. Gas, water, and condensate will be separated from the three-phase stream at the CPF. Residue gas will be re-injected into the reservoir at the CWP located near the CPF. A small amount of the gas will be used to supply fuel for the facility. Produced water will be re-injected into one or more disposal wells at the CWP.

Condensate is the hydrocarbon liquid that condenses from the gas as the pressure and temperature fall below original reservoir conditions during production and surface handling (gathering and processing facilities). The separated condensate will be dehydrated and stabilized at the CPF to meet pipeline specifications.

An airstrip will be built south of the CPF, and a dock will be constructed adjacent to the CWP because no permanent roads exist between Point Thomson and Prudhoe Bay.

The recovered hydrocarbon condensate will be shipped to market through a new 22-mile export pipeline that will extend from Point Thomson to the Badami Development, where it will tie into the existing Badami and Endicott sales oil pipelines, with ultimate delivery to Pump Station 1 on the Trans Alaska Pipeline System (TAPS).

3.1.2 Facility Storage Containers [18 AAC 75.425(e)(3)(A)(i) and (ii)]

Appendix B and Section 2.1.10 provide a summary of the major features of the proposed oil storage containers.

Oil storage start-up is expected to occur in Spring 2005.

3.1.3 Transfer Procedures [18 AAC 75.425(e)(3)(A)(v)]

Fuel transfer procedures are discussed in Section 2.1.5 and Appendix A.

3.1.4 Description and Operation of Production Facilities [18 AAC 75.425(e)(3)(A)(vi)]

See Section 1.8 for diagrams of facilities.

Central Well Pad

The CWP will accommodate the initial drilling operations and drilling storage to support work at the east and west pads. The pad will also be suitable for ongoing well maintenance and service rig access, future drilling activities, and equipment and facilities for gas injection. A pad extension will be provided for a temporary flare to be used during drilling operations. Flaring requirements during facility operations will be handled by the main flare at the adjacent CPF. The drilling rig will have access to electric wireline and slickline units. The rig will employ a closed mud system with no reserve pit or discharges. Cuttings storage capability will be provided among the drilling pads. There will be mobile grind and inject facility with the rig.

Facilities on the CWP will include a separator and fuel gas treating skid for providing early fuel gas and fuel gas for a plant black start. A mud plant, tubular storage, diesel storage, warehouse, and lined cutting storage pit will also be located on the CWP. In cases of white-out storms, the drilling rig contractor will be able to provide temporary facilities for drilling personnel on the eastern and western pads.

Central Processing Facility

The CPF pad layout will accommodate the CPF modules and equipment, temporary and permanent construction and drilling camp and associated water and waste disposal facilities, the camp utility module, the office, warehouse, and shop space, the power generation modules, the control room, the communications tower and building, fuel, water, diesel, methanol, and chemical storage, a cold storage area and associated pipe racks, cable racks, and associated storage equipment, and treatment systems for potable and effluent water. A microwave tower will tie Point Thomson back to the Prudhoe Bay/North Slope communications infrastructure by relay through a Badami microwave tower. In addition, the CPF pad will accommodate the high-and low-pressure flares. Camp housing and catering for drilling personnel will be located at the CPF and supplied by project contractors.

The three-phase production delivered to the CPF will be directed to several process modules. In these process modules, the condensate will be separated and stabilized before it is metered and pumped into the export pipeline. Produced water will be separated and injected into the Class I disposal well on the adjacent CWP. Separated gas will be compressed and injected into injection wells on the CWP (Figures 3-1 and 3-2).

Fuel gas prior to startup of the facility is necessary to provide power to the drilling rigs and construction activities on each pad. The initial two wells on each pad will be drilled using diesel for rig fuel. In order to minimize on-site diesel storage requirements, subsequent wells on each pad will be drilled using natural gas produced from the Thomson Sand through the first well. The condensate associated with this gas will be separated at the surface and re-injected into the Thomson Sand through the second well. Alternative methods under consideration for disposing of the condensate include injection into the tubing by casing annulus, injection into the top of the pre-Mississippian formation, and disposal down the Class I disposal well. Condensate produced during well testing activities will be reinjected in a similar manner.

The permanent CPF power-generating equipment will include four gas turbine-driven Solar-Taurus 70 generator sets. These generator sets will be installed with the three diesel engine-driven essential generators and related switchgear. Transformers and buried transmission cables (13.8 kiloVolt [kV]) also will be installed in the gravel roads to deliver power to the three well pads and the airstrip. This supply will provide power during construction, and power for the operating facilities during normal operations.

Producing Well Pads

Gravel well pads will be constructed at either end of the field. Seven producing wells are currently planned for the east pad and six wells in the west (Table 3-2). Permanent facilities on the pads will include well control and metering equipment, and manifold and gathering pipeline pig launchers. Methanol storage and injection facilities will be provided to allow for cold startups and freeze protection. Space will also be provided on the pad to allow for drilling rig and related support equipment.

Individual well production rates will average 100 mmscf/d and range up to 150 mmscf/d, with variations based on well performance, water content, and operational demands.

THIS PAGE INTENTIONALLY LEFT BLANK

To
Injection Wells at
Central Well Pad

Injection
Compression

HP Flash Gas
Compression

LP Flash Gas
Compression

Fuel
Gas

Flash Gas From Stabilizer

From
Production Wells
at East & West
Well Pads

Separation and
Stabilization

Stabilized Condensate to
Export Pipeline

Produced Water to
Disposal Well
at Central Well Pad

ExxonMobil

POINT THOMSON GAS CYCLING PROJECT
SIMPLIFIED FLOW DIAGRAM

DATE:
April 2003

SCALE:
Not to Scale

FIGURE:
3 - 1

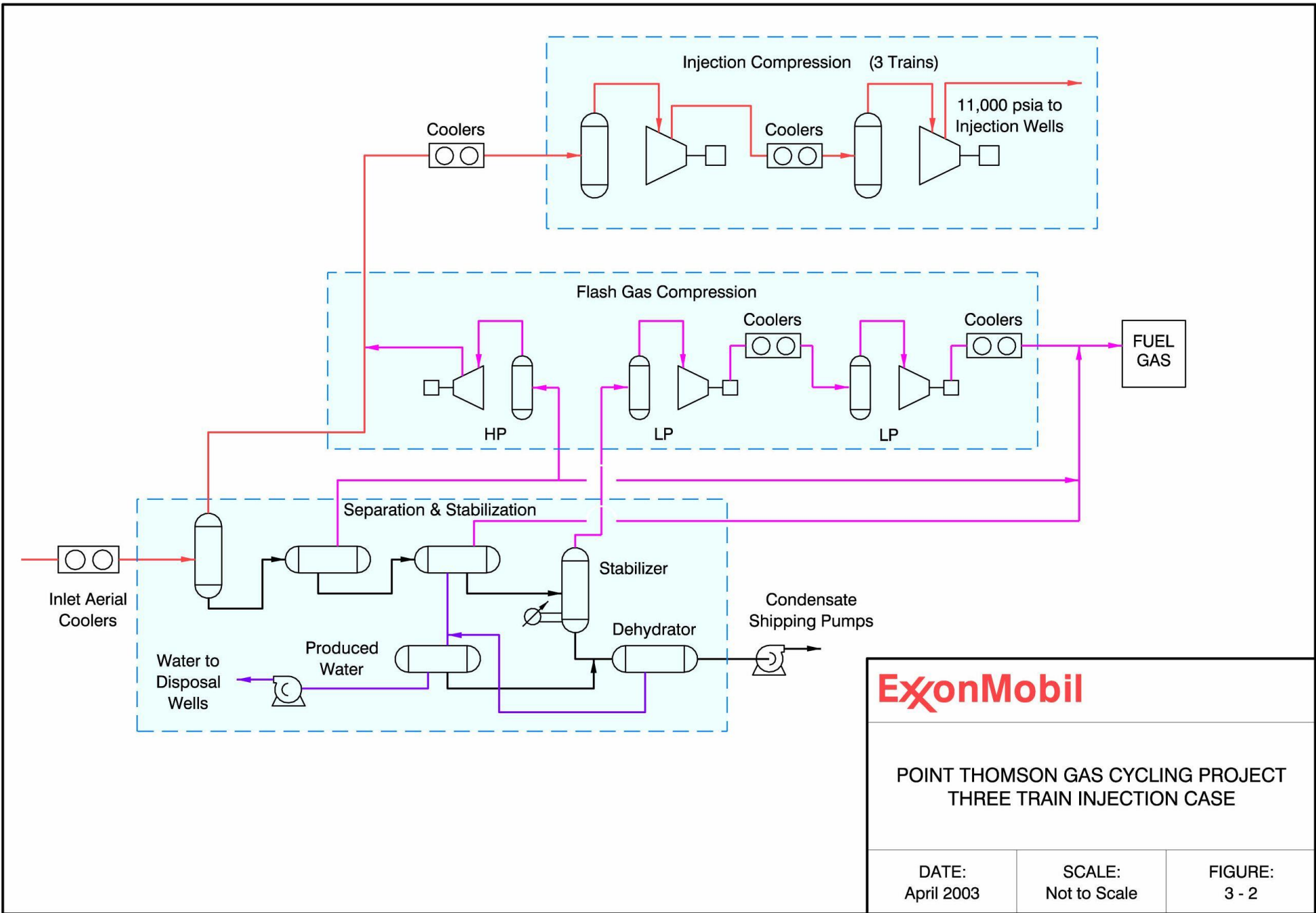

ExxonMobil

POINT THOMSON GAS CYCLING PROJECT
THREE TRAIN INJECTION CASE

DATE: April 2003	SCALE: Not to Scale	FIGURE: 3 - 2
---------------------	------------------------	------------------

**TABLE 3-2
WELL COUNTS**

PAD	NUMBER OF WELLS
West Well Pad	6 Production + 2 potential future wells
Central Well Pad	8 Injection + 2 potential future injection wells and one Class 1 Disposal Well + 2 potential future Disposal Wells
East Well Pad	7 Production + 2 potential future wells
Total	21 Injection and Production + 1 Disposal, up to 30 wells

Wellhead pressures will initially be approximately 8,300 psi gauge (psig) at 32°F at shut-in conditions. Pressures will decline with time as gas and liquids are removed from the reservoir. Production flow rates and downstream pressures will be controlled using automated choke valves. Overriding pressure/flow control and emergency shutdown systems will ensure that flowing pressures remain below the gathering pipeline maximum operating pressure of approximately 3,540 psi-absolute (psia).

Wellhead facilities will consist of the wellhead valving, an automated choke valve, and a well line interconnecting the well to the production manifold. To facilitate production measurement and the testing of well streams, individual three-phase meters will be provided for each producing well.

The produced gas will contain 4 to 5 percent carbon dioxide (CO₂) and will be water-saturated at reservoir conditions. To minimize corrosion, the production well tubing, wellhead, valving, headers, and gathering pipelines will be made of duplex stainless steel (2205) or other suitable corrosion-resistant alloy (CRA).

Point Thomson drilling and completion-related data are as follows:

- Reservoir thickness: up to 350 feet
- Initial Reservoir pressure: 10,250 psi
- Flowing wellhead temperature: approximately 200°F
- Injection wellhead temperature: approximately 155°F
- Formation fluid: natural gas, 0% H₂S, 4.5% CO₂

Thomson Sand well completions will be equipped with a Class V wellhead with control line ports for downhole pressure and temperature gauges, chemical injection, and SCSSVs. The trees will be equipped with two master valves, two wing valves, and a crown valve, and the upper master and outside wing valves will be equipped with actuators. The producers employ 7 1/6-inch, 10,000 psi gas-rated trees. The gas injectors will have 7 1/16-inch, 15,000 psi gas-rated trees. The operating temperature range for wellheads and “Christmas trees” is –75°F to +250°F.

A 13 5/8-inch, 10,000 psi-rated four-ram and one 10,000 psi-rated annular BOP stack (ExxonMobil Type 5-A) and a 10,000 psi-rated choke manifold will be employed for open-hole operations below the surface hole.

Wells will be 40 feet apart.

Condensate Export Pipeline

The Point Thomson export condensate pipeline will be designed, built, and operated as a common carrier system according to proven North Slope design criteria and applicable DOT standards. The export system will consist of a carbon steel pipeline approximately 22-miles-long to transport condensate from the CPF to a connection point with the existing Badami pipeline. The pipeline will have a maximum allowable operating pressure (MAOP) of approximately 2,060 psig. Pig launchers and receivers will be included on this pipeline. From the tie-in point, the existing 12-inch Badami pipeline extends another 25 miles to tie in with the Endicott pipeline, which extends another 10 miles before connecting to TAPS Pump Station 1 in Prudhoe Bay.

The proposed Point Thomson condensate pipeline will be supported on VSMs and will be configured with "Z" type offsets and/or expansion loops to allow for thermal effects. The VSMs will be designed and installed with clearance between the bottom of the pipe and the tundra surface. Design and installation of the VSMs will be completed using standard ExxonMobil and North Slope pipeline specifications and procedures. The VSM design will be performed during the pipeline detailed design. Table 3-4 provides the engineering data as developed to date for the condensate pipeline.

An internal protective coating is not necessary for the pipeline because condensate transported in the line will have low water content and thus would not cause corrosion of the inside wall of the pipeline.

Multi-Phase Gathering Pipelines

Approximately 13 miles of gathering pipelines will carry three-phase production from the producing well pads to the CPF (Table 3-3).

Produced gas from both the east and west well pads will be piped from the well manifolds to the multi-phase gathering pipelines and then to the CPF. The gathering pipelines will be configured with a pig launcher on the well pad end and a pig receiver on the plant end. They will be constructed of corrosion-resistant piping material (e.g., duplex stainless steel [2205]) and run above the tundra on VSMs to the plant. The pipelines will be routed on the inland side of the access roads so the road can act as a containment barrier in the event of a gathering pipeline leak. Adequate spacing will be maintained between the road and the gathering pipelines to avoid hampering caribou movement. This spacing will generally be greater than 200 feet, except where the road and lines converge at the pads.

The well flow rate and inlet pressure to the gathering pipelines will be controlled at about 3,540 psia or lower so that the minimum delivery pressure at the plant is approximately 3,040 psia. Normal flowing temperatures in the gathering pipelines will be over 170°F with temperature drops of 10°F or less. The produced gas will have a hydrate point at flowing pressure of approximately 80°F. Therefore, the gathering pipelines will be insulated to reduce the rate of cooling of the pipeline to ambient conditions when the flow is stopped or restricted. This will allow additional time to resolve operating problems and resume flow before the pipeline must be depressurized to avoid potential hydrate formation and associated problems.

**TABLE 3-3
SUMMARY OF CONDENSATE PRODUCTION PIPELINES**

VARIABLE	WELL LINES	PRODUCED 3-PHASE GATHERING PIPELINES	CONDENSATE SALES PIPELINE
Transported Substance	Sweet gas and condensate, 4.5% CO ₂ and water-saturated.	Sweet gas and condensate, 4.5% CO ₂ and water-saturated.	Sweet condensate per TAPS specification: True vapor pressure limit = 14.2 psia at 105°F and BS&W < 0.35%
Specific Gravity	Not applicable	Not applicable	0.7 to 0.9 (water = 1.0)
Pressure	10,000 psig at flowing wellhead conditions.	4270 psig East Design Pressures Line and 4675 psig - West Line (ANSI 2500#)	2,060 psig maximum operating pressure.
Length	Less than or equal to 1 mile	6 miles East Line 7 miles West Line	22 miles
Facilities	Individual 3-phase meter for each well.	Pig launchers and receivers.	Three 50% duty shipping pumps at Point Thomson CPF. Aerial cooling stations at Point Thomson CPF to cool condensate to pipeline operating temperature. Custody transfer turbine meter at Point Thomson CPF.
Access	Above ground on gravel pad by vehicle and by foot.	Above ground by foot and ATVs.	Above ground by ATVs and helicopter.
Pipeline Design Maximum Throughput	150 million standard cubic feet per day (mmscf/day) nominal design, however, well line throughput will only be limited by gathering line capacity.	1.2 billion standard cubic feet per day (BSCFD) - East Line 1.0 BSCFD - West Line	100,000 bopd
Pipeline Design Temperatures	Maximum: 220°F Minimum: -50°F	Maximum: 220°F Minimum: -50°F	Maximum: 200°F Minimum: -50°F
Pipeline Construction Modes	Wells to production header on well pads.	North Slope VSMS, minimum 5-foot clearance between bottom of pipe and tundra and water crossings. Buried casing in road bed gravel placed on tundra.	Mainline: VSMS, minimum 5-foot clearance between bottom of pipe and tundra surface. Road Crossings: In culverts or casings through road bed gravel placed on the tundra. Creek and Water Crossings: VSMS.
Outside Diameter	8.625 inches	18 inches – East Line 16 inches – West Line	12.750 inches
Wall Thickness	1.125 inches	0.821 inch – East Line 0.799 inch – West Line	Mainline: 0.281 inches Station piping and valve and trap sites: 0.375 inches

**TABLE 3-3 (CONTINUED)
SUMMARY OF CONDENSATE PRODUCTION PIPELINES**

VARIABLE	WELL LINES	PRODUCED 3-PHASE GATHERING PIPELINES	CONDENSATE SALES PIPELINE
Inside Diameter	6.375 inches	16.36 inches – East Line 14.4 inches – West Line	12.2 inches on mainline
Material Grade	CRA, e.g., duplex stainless steel (2205).	CRA, e.g., duplex stainless steel (2205).	American Petroleum Institute (API) 5L Grade X65 carbon steel.
Covering	Above ground: 2-inch polyurethane (PU) foam insulation with galvanized metal jacket.	Above ground: 2-inch PU foam insulation with galvanized metal jacket.	Mainline: 2-inch PU insulation with galvanized metal jacket. Buried road crossings: As main line plus fusion-bonded epoxy.
Inspection Piggable	No.	Yes. Pig launcher on the well pad end and a pig receiver on the plant end.	Yes. Pipeline will be provided with in-line inspection capability by pig launcher and receivers.
Minimum Hydrostatic Test Pressure and Duration	125% of design pressure for 1 hour.	4 hours at minimum pressures of 125% MAOP and 4 hours at 110% MAOP in accordance with American Society of Mechanical Engineers (ASME) B31.8.	4 hours at minimum pressure of 125% MAOP and 4 hours at minimum pressure of 110% MAOP in accordance with DOT (49 CFR 195).
Valve	Wellhead valves and automated choke valve.	Actuated isolation valves at the inlet and outlet of each gathering line.	Mainline: Actuated isolation valves at the inlet and outlet of the pipeline. Check Valves: None.
Design Code and Regulation	ASME B31.8	ASME B31.8	ASME B31.4 and 49 CFR 195.

Gas Injection System

Gas discharged from the re-injection gas compressors will be piped directly to the CWP and injected down the designated injection wells. The injection lines will extend from the CPF to the injection wells on the CWP. They will have maximum working pressures of approximately 12,500 psig and will be only about 1,000 feet long. Because of the proximity of the CWP to the CPF, all injection lines will run on VSMS or on a pipe rack from the compressor area to the injection manifold. Because the gas is relatively dry and warm at injection conditions, carbon steel piping will be used.

Compressor discharge pressures will vary between 8,500 psig and 10,500 psig, depending on well availability and injection flow rate. Design pressure is assumed at 12,100 psig to allow for overpressure during abnormal conditions (relief). Piping will be designed in accordance with American Society of Mechanical Engineers (ASME) B31.8 using a design factor of 0.5 and high-strength piping 5LX 65 or 70.

Dock

The Point Thomson dock will serve a critical role in both construction and operating phases of the project. The 750-foot-long dock will reach to water 9 feet deep and have the capability to land barges carrying sealift modules weighing up to approximately 6,000 tons. It will facilitate the landing of the CPF process modules during the sea lift before startup. The dock will also provide a means of mobilizing drilling rigs and drilling equipment and materials the year before

startup. During construction and drilling, and during the operating phase of the project, the dock will support the resupply by barge of heavy and bulk materials that are not practical to deliver by air or ice road. For example, the dock will berth resupply barges from Prudhoe Bay or Hay River. The dock will also provide launching for response vessels during the summer broken-ice season.

Airstrip

The airstrip at Point Thomson will be used for crew changes year round and equipment and material resupply when ice roads and sea traffic are not available. Regular flights will use Twin Otters, Beachcraft 1900, and similar-sized aircraft, but the airstrip will also handle an aircraft the size of a Hercules C-130, and will be used for well control response equipment, emergency evacuation or for MEDEVAC (medical evacuation) if required. The airstrip facility will include communication and instrumentation for navigational aid.

3.2 RECEIVING ENVIRONMENT [18 AAC 75.425(e)(3)(B)]

The receiving environment consists of the shorelines down-slope of oil pipelines, wells and tanks, and the marine waters and shorelines of the Beaufort Sea.

3.2.1 Water and Weather

The Arctic Coastal Plain has an arctic maritime climate that is very cold. The Arctic Ocean moderates extreme summer temperatures near the coast. Summer fog is common. Maximum summer temperatures reach 71°F to 74°F and the minimum winter temperatures drop below -50°F. The mean annual air temperature at Barter Island is 9.8°F, where it ranges from a mean maximum of 45.1°F during summer months to a mean minimum of -26.6°F during winter months. Table 3-4 presents historical ambient temperatures at Barter Island.

**TABLE 3-4
BARTER ISLAND AVERAGE AMBIENT TEMPERATURE (°F)**

MONTH	MONTHLY MEAN	MAXIMUM DAILY AVERAGE	EXTREME MAXIMUM	MINIMUM DAILY AVERAGE	EXTREME MINIMUM
January	-14.2	-8.0	37.5	-20.5	-53.5
February	-19.2	-13.1	36.5	-25.2	-57.5
March	-15.7	-9.3	34.5	-22.1	-51.5
April	-1.6	-5.9	42.5	-8.9	-43.0
May	20.1	25.2	44.0	15.0	-17.5
June	34.0	38.2	69.5	29.9	8.5
July	39.6	45.2	78.5	34.1	23.0
August	38.5	43.0	74.0	33.8	20.0
September	31.0	34.4	64.0	27.4	2.5
October	14.4	19.3	44.5	9.5	-29.0
November	-1.0	4.6	38.0	-6.5	-45.5
December	-12.1	-6.0	35.5	-18.2	-53.0

ACS
Technical
Manual Vol.
2 Map Atlas
Sheets 91
through 105

Table 3-5 presents the yearly probability of temperature occurrence. The data are based on statistical analysis of 20-plus years of weather data collected at Prudhoe Bay and are used as a basis for approximating annual average available horsepower for turbine-driven equipment. Annual average capacity is calculated by weight-averaging the maximum instantaneous capacities by the likelihood of occurrence for each ambient temperature. Likelihood of occurrence is based on statistical analysis of 16 years of hourly temperature data from Prudhoe Bay. The likelihood of occurrence for -40°F is the fraction of the hourly readings that fall below -35°F . The likelihood of occurrence for -30°F is the fraction of the hourly readings that fall between -35°F and -25°F , and so on. The likelihood of occurrence for 70°F is the fraction of the readings that fall above 65°F .

**TABLE 3-5
PRUDHOE BAY YEARLY PROBABILITY OF TEMPERATURE OCCURRENCE**

TEMPERATURE ($^{\circ}\text{F}$)	PERCENTAGE OF OCCURRENCE
-40	3.3
-30	7.3
-20	10.2
-10	11.4
0	10.6
10	9.7
20	9.3
30	17.2
40	13.9
50	5.0
60	1.7
70	0.4
Average 10.7°F	-

Winds are generally from the east-northeast ($\text{N}70^{\circ}\text{E}$), but wind shifts to the west or northwest are common throughout the summer. Strong westerly and southwesterly winds can occur during storms (Figure 3-3 and Table 3-6).

**FIGURE 3-3
WIND DIRECTION FREQUENCIES AT BARTER ISLAND**

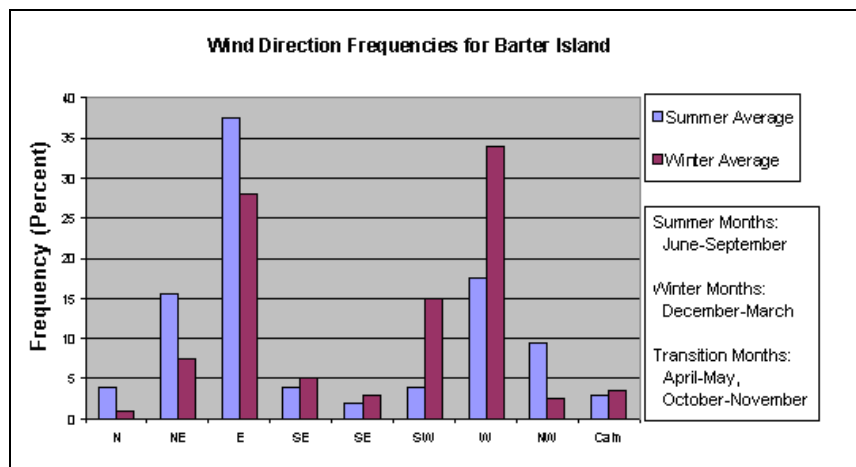

**TABLE 3-6
MEAN AND INSTANTANEOUS WIND**

MONTH	MEAN SPEED WIND (MPH) ¹	PREVAILING WIND DIRECTION	MAXIMUM HOURLY WIND AVERAGE SPEED (MPH) ²	MAXIMUM INSTANTANEOUS WIND ³	
				SPEED (MPH)	DIRECTION
January	14.7	ENE	30.8	81.0	W
February	13.7	WSW	31.2	63.0	W
March	13.3	WSW	25.9	77.0	WNW
April	12.4	ENE	30.4	52.0	W
May	13.7	ENE	28.2	55.0	WSW
June	13.3	E	23.7	38.0	W
July	12.9	ENE	27.3	40.0	SW
August	11.9	ENE	29.5	44.0	W
September	13.1	ENE	28.8	78.0	W
October	13.6	ENE	29.3	58.0	W
November	13.8	ENE	35.7	81.0	WSW
December	13.2	WSW	30.4	72.0	W

¹ Deadhorse Airport
² Prudhoe Bay Unit (PBU) Pad A Monitoring Site
³ Barter Island, National Weather Service Station

Data recorded at Barter Island are representative of conditions along the Arctic coast. Weather data derived for the Yukon Gold No. 1 well site, south of the Point Thomson facilities area, are representative of conditions further from the coast (Table 3-7). Inland locations tend to have more sunshine, less fog, and higher summer temperatures. Because inland areas are warmer than coastal sites, the calculated mean maximum summer temperatures are higher inland, and there is a longer thawing period.

**TABLE 3-7
CLIMATE DATA FOR YUKON GOLD ICE PAD AREA (INLAND)
AND BARTER ISLAND (COASTAL)**

CLIMATE VARIABLES	DERIVED YUKON GOLD ICE PAD AREA CLIMATE DATA	RECORDED BARTER ISLAND CLIMATE DATA
Average air temperature	11.0°F	14.2°F
Mean maximum air temperature	46.5°F	45.1°F
Mean minimum air temperature	-19.1°F	-26.5°F
Thawing index	1,025°F-days	570°F-days
Freezing index	8,620°F-days	8,400°F-days
Length of thawing season	92 days	92 days
Average snow depth	0.5 feet	0.9 feet
Average wind speed	13.5 mph	13.3 mph

Notes:
Thawing °F day: degree days above 32°F
Freezing °F day: degree days below 32°F

At Point Thomson, precipitation yields 5 to 7 inches water equivalent per year. Average visibility is less than 2.5 miles 1 to 4 days per month from October to April and 8 to 16 days per month from May through September.

Oceanography

The principal marine environment within the Point Thomson Development area is a relatively shallow marine lagoon south of a Barrier Islands complex. The lagoon has a width of approximately three to four miles and water depths of typically 5 to 13 feet. The Barrier Islands complex parallels the coast and extends approximately 18 miles from Challenge Island on the west to Flaxman Island on the east, and these are part of the Barrier Islands that separates the lagoon from the Beaufort Sea. Passes or gaps between the Barrier Islands connect the lagoon waters with the Beaufort Sea, and thus, waves, storm surges, and other regional oceanographic processes influence the lagoon waters.

It was noted that the nearshore Beaufort Sea ice season can be categorized into five periods (Dickins, 2002 personal communication):

- Onset of ice overflood leading to initial deterioration of ice nearshore (May/June);
- Progression of ice clearing, leading to initial open water conditions (June/July);
- Summer open water period (July to September);
- Progression of freeze-up leading to stable fast ice cover (October/November); and
- Winter stable ice (December/May).

From year to year, the duration of the open-water season is variable. While freeze-up offshore generally occurs by mid-October, open water caused by storms has been observed as late as February. When freeze-up occurs late, strong early winter storms can produce large waves as winds blow over expanses of open water.

Table 3-8 summarizes the likelihood of extreme open-water physical conditions that could occur yearly and on a 100-year return period.

**TABLE 3-8
OCEANOGRAPHIC DATA SUMMARY**

VARIABLE	1-YEAR RETURN PERIOD (TYPICAL PERIOD)	100-YEAR RETURN PERIOD
Seawater temperature	29°F to 35°F	40°F
Surface currents (preliminary estimates) at Mary Sachs Entrance	2 knots (2.3 mph) for east and west	3 to 4 knots (3.4 to 4.6 mph), (east or west)
Storm surges and water level (preliminary estimates): East wind set-down, West wind set-up	-1 foot mean sea level (MSL) +23 feet MSL	-2 feet MSL +6.7 feet MSL (lagoon)

Bathymetry

The Barrier Islands complex shelters much of the lagoon within the Point Thomson development area from exposure to storm waves generated in the Beaufort Sea during the open-water periods. Mary Sachs Entrance, a broad 2.25-mile pass between Point Thomson and Flaxman Islands, divides the lagoon. The lagoon east of Mary Sachs Entrance is shallow

and is protected by Flaxman Island. West of Mary Sachs Entrance lies a deeper and wider lagoon open to the west.

Water depth in the eastern part of the lagoon near Point Thomson proper is shallow. Shoals are common near the mouth of the Staines River and western distributary of the Canning River and extend toward Brownlow Point. The pass between the east-end of Flaxman Island and Brownlow Point is narrow (1,200 feet) and relatively deep (26 feet). Historical soundings by National Oceanic and Atmospheric Administration (NOAA Chart No. 16045) suggest that the lagoon is asymmetrical with deeper waters near the mainland shore and a gentle slope from the mid-channel north of Flaxman Island. Water depths within the lagoon gently increase toward the west to a depth of 8 feet, approximately mid-length of Flaxman Island, and reach 11 feet immediately northeast of Point Thomson.

Mary Sachs Entrance is a broad and relatively deep pass with a northeast/southwest- oriented channel that extends toward Point Thomson. Water depths within the channel are typically 9 to 11 feet with the 10-foot isobath approximately 2,400 feet north of the mainland shore in the vicinity of Point Thomson. Mary Sachs Entrance provides a break in the protection offered by the Barrier Islands, exposing the shoreline adjacent to and east of Point Thomson to offshore storm events. The increased exposure to waves is evidenced by the well-developed spit and bar formation along the mainland shore.

The western portion of the lagoon is protected by a group of barrier islands known as the Maguire Islands (Challenge, Alaska, Duchess, and North Star Islands). This portion of the lagoon widens from 1.5 miles at Point Thomson to 3.5 miles near Challenge Island. Water depths adjacent to the mainland between Point Thomson and Point Hopson are typically 7 to 10 feet and gently increase to 16 feet at the west-end of the lagoon.

The bathymetry chart available for the area is based on the 1949 and 1950 surveys conducted by the National Ocean Service Coast Survey with additional data from the State of Alaska, U.S. Geological Survey, and the USCG.

In June 1998 and August 2002, Coastal Frontiers Corporation performed a bathymetric reconnaissance, measuring water depths along a potential barge route within the lagoon including Mary Sachs Entrance. The data included a route from Mary Sachs Entrance to the proposed Point Thomson dock.

Tides and Storm Surges

As with other areas along the Beaufort Sea, coast tidal ranges are less than the ranges for storm surges. The tide range is slight, about 0.7 foot, but the range of sea level rise and fall due to major storms (storm surge) can be as much as 8 feet at the shore.

The Coriolis effect is pronounced in high latitudes, causing moving seas to be deflected to the right in the Northern Hemisphere. Therefore, westerly winds tend to force water onto the shore causing an increase in sea level or set-up. Conversely, easterly winds tend to force water away from the coast resulting in a lowered water level or set-down.

Waves

Storm waves in the shallow lagoon waters are smaller than storm waves generated in the deeper Beaufort Sea waters north of the barrier islands complex. Passes between the barrier islands allow higher wave energies to enter the lagoon system as evidenced by the shoreline

near Point Thomson, an exposed portion of the lagoon shoreline immediately south of Mary Sachs Entrance.

Based on National Weather Service records, the longest storm duration (wind speed exceeding 30 knots) was 42 hours for a westerly storm (September 1954) and 66 hours for an easterly storm (September 1979).

Nearshore Currents

The nearshore Beaufort Sea has been studied intensively for nearly two decades, so the oceanography of the region is well understood. As with most shallow seas, the dynamics of the Beaufort Sea are governed almost exclusively by the wind. The currents in shallow water align generally with the wind direction, i.e., east winds produce westward currents and west winds produce eastward currents.

Three forces drive the circulation of the coastal ocean: wind stress, horizontal pressure gradients, and tides. Along the Beaufort Sea coast, astronomical tides are small (less than 0.7 feet) with associated currents that are less than 0.1 knot, except in the narrow passes between barrier islands. Winds are almost always parallel to the coast, with easterlies prevailing about 60 percent of the open-water season, July through September.

Site-specific current measurements were made in a 40-day period throughout August and early September 1997 in the passes on each end of Flaxman Island. Typically, currents within Mary Sachs Entrance were less than 0.6 knots, however at the peak of a severe easterly storm during late August, current speeds were measured at almost 1 knot. Tidal currents observed in Mary Sachs Entrance were typically between 0.01 to 0.2 knots. Active sediment transport was evident with the burial of the current mooring anchor.

Water movement through the narrow channel between Brownlow Point and the east end of Flaxman Island typically reached speeds in excess of 1.2 knots with a maximum-recorded value of 1.7 knots. However, the mooring was fouled prior to a late August storm event in which higher current speeds would have been observed.

Snowmelt River Floods

On the streams flowing into the lagoon, snowmelt floods occur every year. During the long winter, an average of about 5 inches of precipitation falls in the form of snow. A substantial portion of the precipitation is lost to sublimation. For small drainages in the project area, an average of about 3 inches of water generally remains on the ground in the form of snowmelt.

Because of the transport of snow by drifting, the actual amount available in a particular small drainage basin can vary widely depending on the ability of the local relief to trap snowdrifts. During spring snowmelt, the first run-off occurs as sheet flow over the ground surface; because the ground is frozen, infiltration is practically nonexistent. When break-up commences, the first snowmelt runs over the frozen surface of small streams and ponds behind snowdrifts. As break-up progresses, the small drifts are overtopped, and the accumulated meltwater is released to flow downstream until it again ponds behind a larger snowdrift in a larger stream or river. The storage and release process results in an extremely peaked run-off hydrograph. Flow during break-up is both unsteady and non-uniform.

Once the break-up crest has passed a particular point on a stream, the recession is rapid. Typically, the flow on a small stream two weeks after the break-up crest is less than 1 percent

of the peak flow, and the smallest drainages can be completely dry within two weeks. During break-up, the bed and banks of small drainages tend to remain frozen, and erosion is limited.

Flood Timing

Floods on small streams have historically occurred as a result of snowmelt, which responds to a rapid, seasonal increase in temperature. As a result, snowmelt floods on a given stream tend to occur at about the same time each year. Rivers originating in the Brooks Range flood about the first week of June, while smaller Arctic Coastal Plain streams crest about one week later than the large rivers. The largest floods tend to be associated with later break-ups. Small streams near the coast tend to be the last to break up.

In general, the year-to-year time lag between the earliest and the latest break-up on a stream is approximately two weeks. The small, un-named coastal streams that cross under the Point Thomson condensate export oil pipeline typically break up two weeks after the mid-May break-up of the Sagavanirktok River.

Seventeen streams flow under the Point Thomson condensate export pipeline east of Badami, as indicated on ACS *Technical Manual, Volume 2, Map Atlas* maps. Six of the streams were studied by Dames and Moore (1983) and Hydrocon (1982). The largest is East Badami Creek, labeled by Dames and Moore (1983) and Hydrocon (1982) as the “un-named creek at milepost 31.8.” Four other streams flow under the multi-phase flowline between the Point Thomson East Pad and the CPF.

ACS
Technical
Manual,
Volume 2

Studies of two creeks provide examples of break-up during the first week of June, as follows:

East Badami Creek originates in the foothills and discharges into Mikkelsen Bay (Dames and Moore, 1983). The creek was still snow-covered without signs of break-up on May 30, 1983. On June 2, some sheet flow and open water were noted. The next day, the water had risen one foot and flooded the banks. Some anchored (bottom-fast) ice was lifting. On June 4, 80 percent of the channel bottom was covered by anchored ice and most of the water flowed over it. On June 7, open water flowed at 3.5 feet per second (2.4 mph); ice floes were up to 2 feet thick and 5 to 10 feet wide and stationary in the creek. Most of the bottom-fast ice was still in place.

On July 14, 1982, the East Badami Creek discharge was measured as less than 2 cubic feet per second (cfs) (Hydrocon, 1982). On July 15, 1983, the flow was 2.5 cfs, on August 22 it was less than 1 cfs, and on September 15 it was 23 cfs (Dames and Moore, 1983).

The un-named creek 2 miles east of Bullen Point drains 12 square miles of the Arctic Coastal Plain and discharges into Mikkelsen Bay. On June 1, 1983, the stream was still snow-covered and showed no indications of break-up. On June 4 and 5, the banks were flooding and small ice pieces were floating at 4 feet per second (2.7 mph). By June 7, the stream was completely open and all the bottom-fast ice had lifted and drifted downstream. On July 15, 1983, the discharge was less than 1 cfs. On August 22 the flow was zero. On September 15, it was 4 cfs (Dames and Moore, 1983).

Rainfall Floods

Summer floods are not anticipated to produce design floods for the Arctic Coastal Plain streams because the rainfall intensity is low and tundra and thaw lakes have a relatively large capacity to absorb and retard resultant run-off. However, summer floods resulting from

unusually large rainstorms in the Brooks Range occur on rivers originating in the Brooks Range, such as the Sagavanirktok River. These floods are not frequent but may be larger than typical break-up floods.

3.2.2 Sea Ice

Descriptions of nearshore ice conditions in this section are a communication from DF Dickins and Associates (2002). This description provides a guide to ice conditions affecting marine operations that support the Point Thomson development. The emphasis here is the typical annual ice cycle from break-up to freeze-up.

Numerous industry and government references describe general ice conditions in the Alaskan Beaufort Sea and along the North Slope. Much of this material deals with the morphology and dynamics of the floating fast ice; shear zone, and seasonal pack ice in water depths well beyond 6 feet, corresponding to the approximate seaward limit of the bottom-fast or grounded-fast ice zone.

The limited number of reports dealing with nearshore observations and the lagoon areas often focus on the density and location of strudel scours affecting the integrity of buried pipelines.

This section describes the nearshore ice environment near the Point Thomson Development, encompassing the following geographic areas:

- Lagoon areas inside the barrier islands from the mouth of the Canning River westward through Lion Bay into Mikkelsen Bay.
- Beaufort Sea up to 3 miles offshore (40-50 feet of water) of the barrier islands from north of the mouth of the Canning River westward to Challenge Island.

In addition, the timing and pattern of nearshore ice clearing in Foggy Island Bay is mentioned as it relates to the regional clearing along the coast from Brownlow Point to Prudhoe Bay/West Dock. Figure 3-4 shows the nearshore lagoon and immediate offshore region out to approximately 50 feet of water (just inshore of the 10-fathom contour shown on the chart). In most years, the entire area falls within the stable landfast ice zone, with the mobile pack ice typically found in water depths beyond 60 feet.

In this description, satellite images were used to visualize the typical sequence of break-up and clearing along shore, following the spring overflood. These images include several recent color scenes acquired by the Landsat 7 between 1999 and 2002, and a series of historical black and white Landsat images from the period 1973 to 1986. This description also draws on a number of available references in the public domain. Published sources include:

- *Beaufort Sea Ice Atlas* prepared by Dickins Associates for SOHIO (1984), and the *Alaska Marine Ice Atlas* prepared by LaBelle and Wise (1983). The ice maps in these atlases tend to cover too large a scale to be of much value in describing local conditions but they provide an indication of overall trends in freeze-up and clearing dates and duration of open water.
- Joint-industry studies: principally a series of reports covering freeze-up and break-up along the North Slope in the period 1980 to 1985 by Vaudrey & Associates (tableted as public documents in the preparation of the Northstar Environmental Impact Statement [EIS]; U.S. Army Corps of Engineers, 1998);

**FIGURE 3-4
GENERAL LOCATION MAP SHOWING THE ICE DISCUSSION AREA**

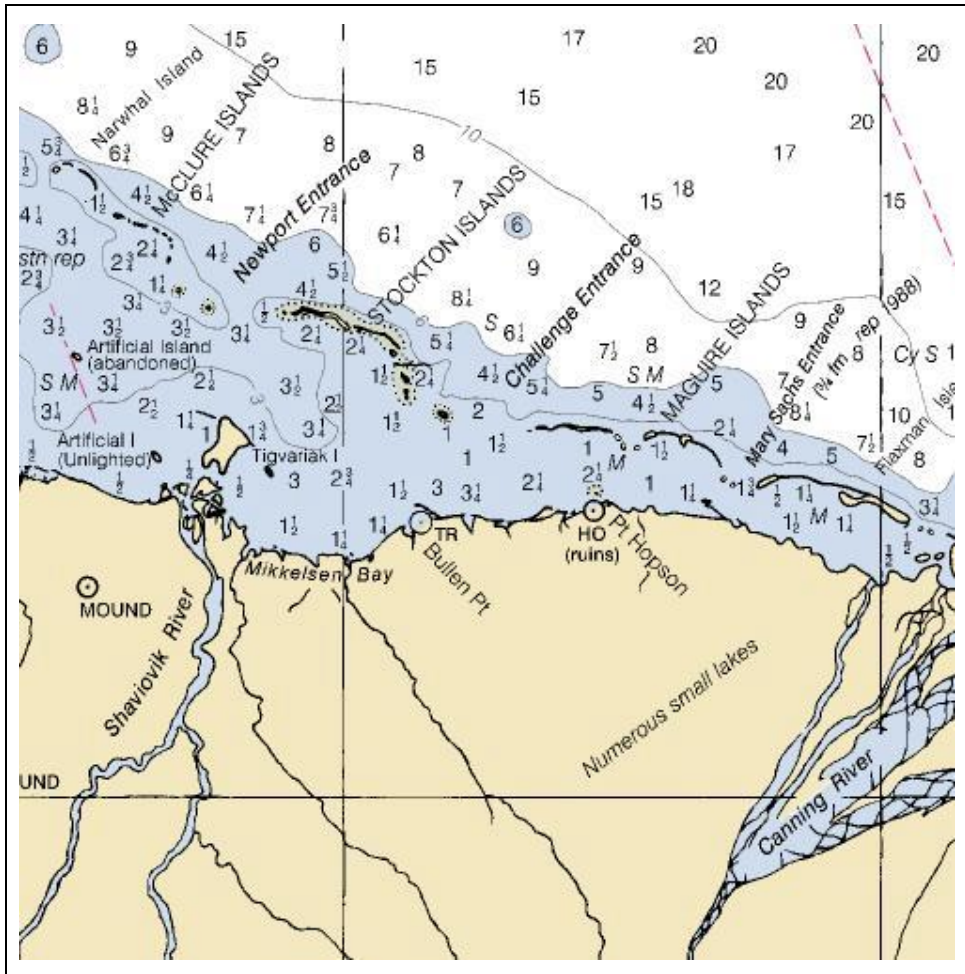

- Comprehensive descriptions of the ice environment at particular coastal sites prepared by Vaudrey & Associates as part of the "Oil Spills in Ice Discussion Paper" (2000).
- A comparative study by Atwater of historical break-up and freeze-up patterns off the major river deltas in the Prudhoe Bay area (including the Canning River) completed in 1991 as part of the 1989 and 1990 Endicott Environmental Monitoring Programs.

The following sections describe the ice environment sequentially through a typical season, starting with the first onset of ice overflow and closing with the establishment of a stable winter ice cover in November.

Ice Overflow and Initial Open Water (May/June)

The transition from a stable, growing winter ice cover to first ice deterioration begins in late April or early May with longer daylight hours and warmer air temperatures. By early-to-mid May, the ice sheet loses much of its bearing capacity, to the point that ice roads may be unsuitable for heavy loads or conventional wheeled vehicles.

Warm air temperatures in June lead to the formation of melt ponds on the top of the landfast ice, especially where the surface is contaminated with dirt either left from drainage of overflow waters, or windblown off the nearby land. In late May or early June at the time of river overflow, melt ponds usually cover less than 10 percent of the landfast ice area beyond the overflow limits. Many melt ponds develop holes all the way through the sheet ice due to enlargement of brine drainage channels.

For a brief period, the sea ice can appear almost totally flooded by snow meltwater. A Landsat image from June 4, 1983 shows almost the entire lagoon area from Brownlow Point to Badami as flooded ice. The ice appears as open water at first glance, but submerged ice under the meltwater is just visible on the imagery. Only one week earlier, a May 28 image shows overflow just starting with no water on the ice apart from immediately off the river deltas. The change in ice appearance in this case is linked to snowmelt on the sea ice, not river overflow. Historical records point to 1983 as a year with an unusually early river overflow, followed by drainage of water on the ice one week to 10 days ahead of normal drainage (Atwater, 1991).

The surface ice appearance changes dramatically over a few days as the meltwater from snow or river overflow drains through the deteriorating sheet. By late June just before break-up, the number of melt ponds has increased dramatically, covering approximately 40 percent to 50 percent of the sheet ice surface. Ice thickness at the time of break-up nearshore is variable because of the melt pool topography but averages between 3 and 4 feet depending on where the measurement is taken (2 to 3 feet less than the end-of-winter thickness).

The progression of break-up at many operating fields along the North Slope is largely controlled by the timing and extent of river outflow (e.g., Point McIntyre PM1, Endicott). The transition from the winter to summer ice season in these areas begins with the break-up of ice in upland rivers triggered by snowmelt in the upland drainage basins, and overflowing of the bottom-fast and floating sea ice just offshore of the river deltas (Kuparuk and Sagavanirktok) during late May or early June. During late May or early June, the rapidly rising stage levels float the river ice off the bottom in the river channels. A wave of rapidly building meltwater moves downstream to flow out on top of the still solid sea ice frozen to the seafloor along the delta fronts (i.e., bottom-fast ice) and out onto the floating fast ice.

The river overflow water reaches depths of 2 to 5 feet on top of the nearshore sea ice. Off the major rivers (e.g., Colville, Kuparuk), this fresh water flood boundary often extends out to deeper water where it has an opportunity to drain through the floating fast ice in water depths of 6 to 30 feet. However, near Point Thomson the overflow from a small river such as the Staines is localized in shallow water within the lagoon and does not have an opportunity to spread onto the floating ice beyond the barrier islands.

Eventually, the overflow water loosens the bottom-fast ice, allowing it to pop up to the surface. Within the overflow zone, the top of the now floating drained ice is usually left covered with a layer of silt deposited by the floodwater. Typically by mid- to late-June, about two to three weeks after the river flooding has ceased, most of the landfast ice within the overflow zone melts in place from a combination of the fresh, relatively warm water and the increased heat absorption by the dirty ice.

This overflow effect from the two major rivers (Sagavanirktok and Kuparuk) leads to the rapid clearing of over 100 square miles of fast ice between Endicott and Oliktok (Dickins et al., 2001). However, in the Point Thomson area, the localized overflows from smaller rivers and creeks are not sufficient to control the ice clearing within Leffingwell lagoon (south of Flaxman

Island). A combined overflow from the west channel of the Canning River discharging to the west of Brownlow Point, and the Staines River is largely confined in a local area less than a few miles in extent. An even smaller overflow occurs in Mikkelsen Bay off the mouth of East Badami Creek (see observations from satellite images described below).

Although too small in extent to show on historical satellite images (less than 100 meters), localized minor overflows likely occur at the mouths of numerous creeks that drain sections of the Arctic Coastal Plain. Typical watersheds are in the order of tens of square miles. Not all of these streams or creeks have sufficient discharge to flood the coastal sea ice but some could produce local overflowing out to distances of a few hundred feet from shore. In some cases, these events may not occur every year.

As an example of overflowing in the study area, a Landsat image from May 29, 1981, shows the overflow from East Badami Creek extending approximately 3,000 feet offshore and to the east. To the west, a narrow (few hundred feet) band of open water spread alongshore as far as the current dock. The No-Name River to the west of Badami (ACS Map Sheet 91) was also overflowing onto the ice, independently of the much larger Shaviovik overflow. Historically, the timing of river overflow (using the Canning as a baseline) in 1981 was within a few days of the long-term mean (Atwater, 1991).

A Landsat image (June 1981) shows rotting but still continuous ice throughout the lagoon area. The only visible signs of ice clearing in the study area were a small patch of open water between the mouth of the Staines River and the west channel of the Canning River (3,000 to 4,500 feet in extent), as well as the localized overflow already noted off East Badami Creek at the end of May (unchanged in extent).

Figure 3-5 is a Landsat 4 scene showing conditions 48 hours after drainage of floodwaters from the major rivers (left to right, the Sagavanirktok, Shaviovik, and Canning rivers) in 1986. The dark areas off the large deltas include a mix of still flooded bottom-fast ice and areas of drained ice with sediment deposited by the overflow. Also clearly visible are the still flooded nearshore areas immediately off the mouth of the Staines River, No-Name River west of Badami, and East Badami Creek. In addition, the un-named stream emptying into the ocean at Bullen Point is open and flowing (dark) to within a few miles of the coast.

In summary, the timing of the main overflows affecting the Point Thomson development area (Staines and Shaviovik) mimic, within a few days, the progression of the nearby Canning River which discharges large volumes predominantly into the west side of Camden Bay. Initially, most of the overflow area off the Canning River is isolated from the lagoon areas to the west by Brownlow Point. Eventually, the initial clearing associated with the Staines River and West Canning overflow expands around Brownlow Point to become contiguous with the much larger clearing off the Canning Delta. This connection generally occurs in late June. By this time, the open water areas, which initially formed off the Shaviovik, Kadleroshilik, and Sagavanirktok Rivers, have also become continuous. The last area to clear (one to two weeks later) tends to be the coastal section between Point Thomson and Bullen Point (an area not directly impacted by river overflow).

**FIGURE 3-5
 LANDSAT 4 IMAGE JUNE 13, 1986, SHOWING COASTAL ICE CONDITIONS
 APPROXIMATELY 48 HOURS FOLLOWING FLOODWATER
 DRAINAGE FROM THE MAJOR RIVERS**

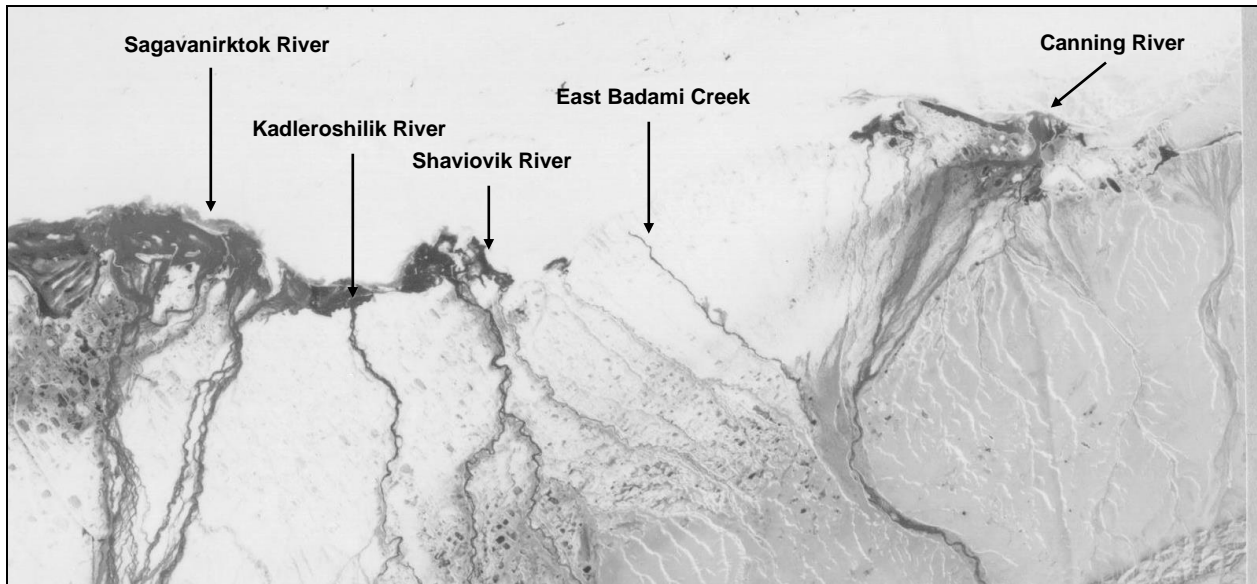

Atwater (1991) documents the historical record of overflood development and initial ice clearing off the deltas of the major river systems in the Prudhoe Bay area. Her data show minor differences between the onset of river flooding from the different river systems, with the Sagavanirktok River tending to flood first (mean May 20), followed by the Canning River three days later and the Kuparuk River four days later still. Specific years could see reversals in this pattern. As the closest large river to the study area, the historical break-up record for the Canning River is summarized in Table 3-9 from Atwater's analysis. Timing of break-up events is variable from year to year, depending on a range of climatic factors. Early and late clearing could occur from 10 to 20 days before or after the averages shown.

**TABLE 3-9
 HISTORICAL BREAK-UP SEQUENCE FOR THE CANNING RIVER, 1974-1990
 (ATWATER 1991)**

MILESTONE EVENT	AVERAGE DATE
River Channel Swelling	16 - May
Major Flooding	23 - May
Floodwater Drainage	06 - June
Open Water in the Delta	20 - June
Break-up of Floating Fast Ice (Camden Bay)	30 - June
Ice Free Conditions	21 - July

Figure 3-6 shows a Landsat 7 browse image (reduced resolution) acquired on June 18, 2000. This scene captures the nearshore ice in the final stages of deterioration before wide-scale clearing in the lagoon areas. Notice local open water areas near the larger river delta and near Point Thomson shoreline.

**FIGURE 3-6
DETERIORATED ICE IN THE LAGOON AREAS**

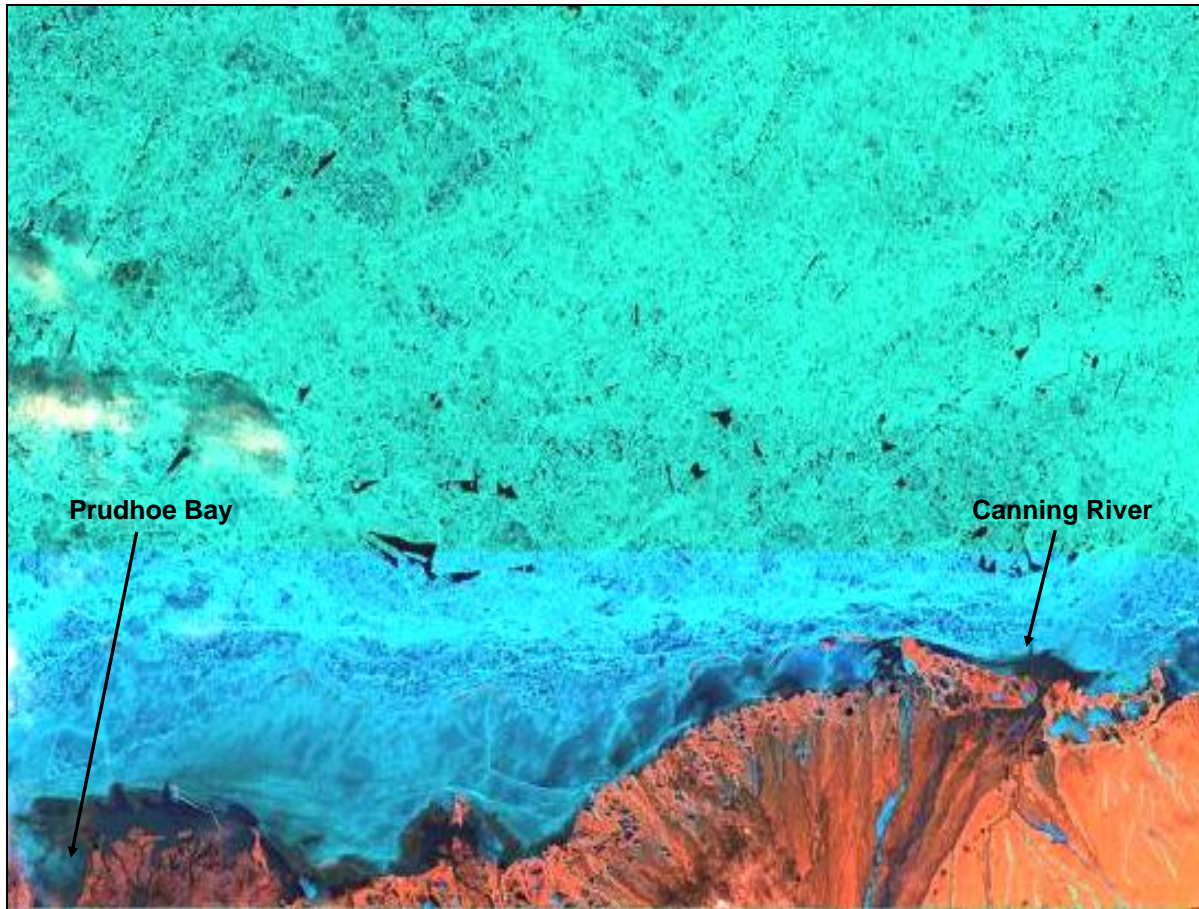

Progression of Break-up Leading to Open Water

While the lagoon areas open up through a combination of river overflow and *in situ* melting (aided by sediment on the ice and the influx of relatively warm fresh water), the floating fast ice outside the barrier islands continues to melt in place from the surface down. The initiation of break-up offshore is related to lines of weakness that tend to develop along a series of melt ponds or old thermal or stress cracks (Vaudrey, 2000).

By the first week in July, open water is typically present in an arc around Brownlow Point, encompassing the very shallow lagoon area east of Point Thomson, bounded by Flaxman Island to the north. At this time, a second expanse of open water usually stretches in a broad arc from the south shore of Mikkelsen Sound (vicinity of Badami) across Foggy Island, around the Sagavanirktok Delta (encompassing Endicott) and stretching as far as Oliktok within Simpson Lagoon, and into the Colville River Delta. These are typical or median conditions; delayed or early melt or overflow affect nearshore ice clearing dates by up to 15 days.

By mid-to-late June, the remaining floating fast ice in central Mikkelsen Bay is usually still intact but reduced to 3 to 4 feet in thickness, with many cracks and through-melt holes. Break-up of the remaining nearshore fast ice occurs between the third week in June and the first week of July, with a median date of July 1 and a standard deviation of 6 days. The length of

the broken ice period near Badami was estimated by Vaudrey (1998) as typically 7 to 10 days (3 weeks maximum).

Once the lagoon ice has cleared, the deteriorated offshore fast ice begins to fracture and becomes mobile in early July, usually triggered by a wind event. Concentrations steadily diminish through melting and wave and floe interactions over a period of two to three weeks. Remaining broken ice at this time moves back and forth in response to wind shifts, in belts and patches of varying concentrations (expressed as tenths coverage). By the end of July or the first week of August, the study area typically becomes open water (defined as less than 1/10 ice concentration) out to water depths in the 40- to 60-foot range more than 3 miles off the Barrier Islands. Figure 3-7 shows fairly typical conditions for late July in the study area with substantial patches of rotting ice and isolated heavy floes still present in deep water north of the Barrier Islands, but almost complete clearing and open water along the coast to Prudhoe Bay and beyond into Harrison Bay. Figure 3-7 is a Landsat 7 image taken July 23, 2001. It shows the area from Brownlow Point westward to West Dock at Prudhoe Bay.

FIGURE 3-7
LANDSAT 7 JULY 23, 2001, SHOWING OPEN WATER ALONG THE COAST FROM
BROWNLOW POINT TO WEST DOCK

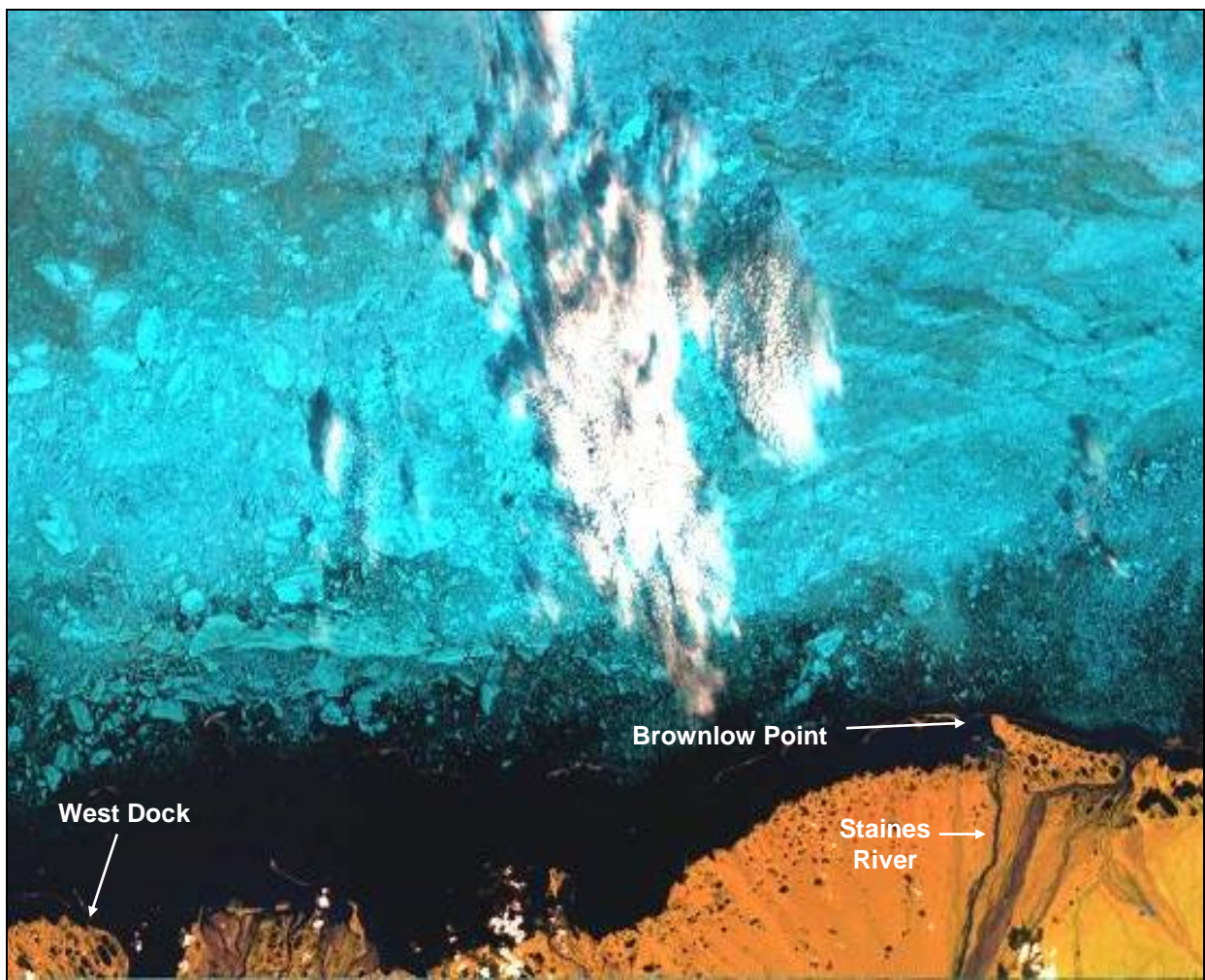

Once established, open water conditions prevail until freeze-up (see below). There have never been any instances of drift ice entering the lagoon area between Brownlow and Bullen Points during the summer months in concentrations greater than 1/10 (August/September). The median duration of open water in the lagoon area is 12 weeks, with a variability of up to two weeks representing summers better or worse than average in terms of break-up and freeze-up (Dickins, 1984). Immediately outside of the Barrier Islands (out to the 50 foot water depth) the duration of open water drops by about two weeks and, in some summers, is reduced by several weeks through temporary pack ice invasions.

Vaudrey's annual break-up studies along the Beaufort Sea coast in the 1980s provide a valuable record of the patterns and variability of ice clearing. A number of these observations are summarized below for the years 1984 and 1985 using reports tabled publicly in the Northstar EIS process (US Army Corps of Engineers, 1998).

The following summary is paraphrased from Vaudrey (1986a) reporting on the 1985 break-up.

June 1, 1985: Entire study area still 10/10. Shaviovik River overflow boundary reaches as far as Badami in Mikkelsen Bay. Canning West branch overflow reaches as far as the Staines River mouth.

June 25-July 2, 1985: Study area still 10/10 ice with open water within the area previously flooded by the Canning and Staines Rivers - no expansion of open water west of the Staines River. No opening in Mikkelsen Bay. Foggy Island Bay is open from Point Brower to the Kad River.

July 3-7, 1985: Open water at the eastern end of lagoon has spread as far as Point Thomson Unit # 3 and out to Flaxman Island. Mikkelsen Bay is open from the north shore of Tigvariak Island to Bullen Point and to the west off the Sagavanirktok Delta and Prudhoe to West Dock. The rest of the inshore lagoon area from Point Thomson to Bullen Point is 5-6/10 rotting fast ice. Offshore area north of Flaxman is still 7-8/10 ice covered out to 30 feet of water, with 9/10 ice beyond.

July 24, 1985: Entire study area inside the islands is open water. To the north of the islands (Flaxman to Challenge Entrance) concentrations range from 2-4/10 out to 30 feet of water and 9/10 beyond. To the west (as far as Harrison Bay) the entire area inside of 30-40 feet of water is open water.

The following summary is paraphrased from Vaudrey (1985a) reporting on the 1984 break-up.

July 7, 1984: Open water stretches around Brownlow Point and as far as the East tip of Flaxman. Lagoon areas off Point Thomson mobile 8-9/10 ice, with Mikkelsen Bay still 10/10 ice past Bullen Point. Offshore area outside of the Barrier Islands open out to 30 feet of water with 7-8/10 in deeper water. Open water out to about 20 feet of water off Foggy Island Bay and around the Sagavanirktok Delta to include all of West Dock.

July 17, 1984: Open water in the lagoon area south of Flaxman. Lagoon areas from Point Thomson west to Bullen Point 7-9/10 ice reducing to 4-5/10 in north Mikkelsen Bay. Southern part of the Bay from Tigvariak Island across to Bullen Point is open. From west of the Shaviovik River to West Dock, the entire coast is clear out to 30 feet of water.

Progression of Freeze-up Leading to Stable Ice Cover

The initiation of freeze-up along the coast between Badami and Point Thomson ranges from mid-September to the last week in October, with a median date of October 5 and a standard deviation of 8 days. Moving broken ice is rarely encountered nearshore in this area (Vaudrey, 1998). Most of Mikkelsen Bay and the lagoon areas to the east become entirely ice-covered within 7 to 10 days after freeze-up begins. This young first-year ice (4 to 10 inches thick) may be susceptible to movement and deformation by storm winds during this period.

After the sheet ice reaches a thickness greater than 8 inches, typically by mid-to-late October, the ice cover in the lagoon shallow areas becomes relatively stable, confined by the island chain stretching west from Brownlow Point. In Mikkelsen Bay, with the broader expanse of ice inside the Islands, the sheet may take slightly longer (up to five days) to stabilize, but this entire area is characterized by static smooth ice throughout the winter (9 years in 10). No movements of the young sheet ice in Mikkelsen Bay were observed or measured after November 1 during the past 20 years (Vaudrey, 1998).

In terms of coastal susceptibility to early winter ice ride-up or pile-up when the sheet ice is less than two feet (Oct/Nov), the area inshore of the barrier islands from the Canning River to Point Thomson was rated as "0" (no events observed). The coast from Point Thomson west to Bullen Point was rated as "1" (one event observed over three years). Mikkelsen Bay and Foggy Island Bay were rated as "0". The seaward facing shorelines of the barrier islands were rated as "1" for Flaxman (infrequent or inconsequential), and "2" for Maguire Islands (moderate or 2-3 events observed) (Vaudrey 1985c).

Vaudrey's annual freeze-up studies along the Beaufort Sea coast in the 1980s provide a valuable record of the timing and character of the initial ice formation and expansion of the fast ice out from shore. A number of observations are summarized below for the years 1984 and 1985 using reports tabled publicly as part of the Northstar EIS process (U.S. Army Corps of Engineers, 1998).

The following summary is paraphrased from Vaudrey (1985b) reporting on the 1984 freeze-up.

October 23, 1984: Young fast ice edge in 30 to 40 feet of water north of Flaxman Island. Two-mile-wide open lead running along the ice edge with 9/10 of young and new ice offshore. Large area of grounded multi-year ice off seaward side of Stockton and McClure Islands (Vaudrey, 1985).

The following summary is paraphrased from Vaudrey (1986b) reporting on the 1985 freeze-up.

October 8, 1985: 8-9/10 new ice in the lagoon areas with open water offshore. Large area of grounded old ice north of Stockton Islands in 30 to 40 feet of water.

October 30, 1985: Ice edge along the 30-foot water depth one mile off Flaxman Island, bordered by a one to two-mile lead — 8-9/10 new and young ice forming further offshore.

November 15, 1985: Ice edge falls along the north side of Flaxman Island with an 8-10 mile lead further out. Solid ice in the lagoon areas. Large ice pileups on the north side of Alaska Island and off the northeast tip of Flaxman Island. Inshore ice protected from any deformation.

December 1-2, 1985: Ice edge close inshore for this time of year — approximately 1 mile off Flaxman Island in 30 feet of water. 20-foot-high shear wall along the edge of the fast ice with 30 to 40-mile-wide lead of mostly open water and some new ice to seaward.

Winter Ice Conditions (November to May)

The winter period is characterized by stable landfast (also called shorefast) ice throughout the study area. The sheet ice grows to an average maximum thickness of 6 to 7 feet by the end of May. This means that ice in the shallow waters throughout most of the lagoon between Point Thomson and Brownlow Point becomes frozen to the sea floor at the end of the ice growth cycle.

Leffingwell Lagoon as well as Foggy Island Bay, Prudhoe Bay and Simpson Lagoon are characterized by Vaudrey (1985c) as First-year Morphology Zone I:

"First-year sheet ice usually remains intact after initial formation at freeze-up. Very smooth with no ridging. Water depths such that sheet ice is bottom fast by end of winter."

The area immediately offshore of the Barrier Islands out to 3 miles off Flaxman Island (60 feet of water) was characterized as Zone III:

"Landfast ice susceptible to movement until the ice becomes 2-3 feet thick sometime in December. Earlier ice movements during freeze-up may create rubble piles or grounded ridges up to heights of 20 to 30 feet. Sheet ice may be relatively smooth just north of the Barrier Islands but heavily deformed ridges and rubble piles often occur at the offshore boundary of this zone."

Once the nearshore ice is established and stable, the seaward fast ice remains close to the 60-foot water depth in most years. Satellite analysis by Dickins (1985 unpublished) showed that the average water depths at the ice edge were approximately 30 feet in November, 45 to 50 feet from December to March, and out to 75 feet in April and May. Off Flaxman Island, these water depths correspond to distances of 5 to 6 miles from shore in the November/December period, 7 to 8 miles from January to March, and 11 to 12 miles from April to May. The June ice edge tends to be a few miles closer to shore than the late winter maximum.

3.2.3 Potential Routes of Discharges [18 AAC 75.425(e)(3)(B)(i)]

The ACS *Technical Manual, Volume 2, Map Atlas* contains maps and information on the potential routes of spilled oil, identifies containment sites, distinguishes sensitive receiving environments, and shows the latitude and longitude coordinates.

Potential routes of discharge are as follows: shorelines down-slope of oil pipelines, wells and tanks; and marine waters and shorelines of the Beaufort Sea adjacent to the industrialized North Slope.

ACS
*Technical
Manual,
Volume 2,
Map Atlas,
Sheets 91
and 96
through 105*

3.2.4 Estimate of RPS Volume to Reach Open Water [18 AAC 75.425(e)(3)(B)(ii)]

None of the condensate from the winter blowout scenario is expected to reach open water. The percentage of a summer well blowout RPS volume that would enter open water is

illustrated in Section 1.6.14. One hundred percent of the condensate that might fall from pipeline leaks directly over streams could reach open water. No diesel from a tank spill would reach open water because the fuel would be retained by the secondary containment area and gravel pad. Site-specific descriptions of routes of travel and measures to prevent oil from reaching open water are provided in Section 1.6.14.

3.3 COMMAND SYSTEM [18 AAC 75.425(e)(3)(C)]

Incident Command System

The organization for oil spill response at Point Thomson will be an Incident Command System (ICS). It will provide clear definition of roles and lines of command with the flexibility for expansion or contraction of the organization as necessary. Personnel with roles in the ICS will comprise the Point Thomson IMT and are listed in Section 1.2. Point Thomson's proposed IMT is compatible with the state's oil spill response structure outlined in the Federal/State/Tribal Unified Plan for Alaska.

ACS
*Technical
Manual,
Volume 3*

In most Level I incidents, the Point Thomson SRT will have the capabilities to effectively control the incident.

ACS Tactic
L-8

Level II and III responses will be initiated by the Incident Commander. The IMT may be activated by the Incident Commander to support the field responders and to coordinate the collection and distribution of information.

ACS
Tactics A-1,
A-2 and A-3

ACS will be activated to stand by for spills until an assessment is performed. Once the assessment is complete, ACS will be either released or mobilized. For Level II and III responses, ACS will provide manpower and equipment resources from Point Thomson and Deadhorse to assist in spill containment and recovery. The North Slope operators coordinate with ACS to ensure that a reserve of trained staff is available for an extended spill response.

Unified Command

Leadership of the proposed ExxonMobil Point Thomson IMT comprises a Unified Command for Level II and III events. The Unified Command members will be ExxonMobil's Incident Commander, the FOOSC, the SOOSC, and the Local On-Scene Coordinator (LOSC), as outlined in the ARRT's Unified Plan for Alaska. Details of the management structure in a spill response are provided in the ACS *Technical Manual, Volume 3*. Section 2 in Volume 3 discusses the escalation of the IMT. Appendix B of Volume 3 contains a description of position responsibilities and checklists. Note that the proposed Point Thomson SRT fulfills functions of the Tactical Response Team discussed in ACS *Technical Manual, Volume 3*.

ACS
*Technical
Manual,
Volume 3*

The primary responsibilities of the Unified Commanders are as follows:

- Establish objectives and priorities.
- Review and approve tactical plans developed to address objectives and priorities.
- Ensure the full integration of response resources.
- Resolve conflicts.

The responsibilities are typically exercised through periodic, highly focused Unified Command meetings.

The Unified Command structure is established and superimposed at the top of the IMT. The Unified Command provides overall direction by establishing strategic objectives, and response priorities to be addressed by the IMT through the planning process. Moreover, it reviews and approves the products of the planning process (i.e., Incident Action Plans) developed by the IMT to address the objectives and priorities.

This position at the top of the IMT also facilitates the integration of response resources. For the agency representatives, it allows them to determine the appropriate roles for agency personnel and to position their staff optimally within the IMT. For the Responsible Party, it ensures that members of the IMT have access to expertise without diluting their ability to manage response operations.

The role of the agency representatives in the Unified Command is to fulfill their legal responsibilities (i.e., to direct and/or monitor response operations), while allowing the Responsible Party to manage the emergency response operations.

3.4 REALISTIC MAXIMUM RESPONSE OPERATING LIMITATIONS [18 AAC 75.425(e)(3)(D)]

The realistic maximum response operating limitations (RMROLs) are described in the ACS *Technical Manual*. Environmental conditions can sometimes limit response work. Some limitations are based on safety, and others concern equipment effectiveness. The ACS *Technical Manual* lists the percentage of time some variables reduce effectiveness of response for planning purposes.

ACS Tactic
L-7

The single most limiting factor of mechanical containment and response effectiveness is broken ice conditions. However, broken ice conditions can aid oil spill cleanup by *in situ* burning because the ice provides natural containment. For an oil spill on a continuous sheet of sea ice, the ice provides a barrier between the oil and the underlying water column.

Shallow nearshore water also constrains response equipment. ACS maintains several shallow-draft vessels and skimmers to operate in shallow water.

ACS Tactic
L-6

Weather can wield significant influence over oil spill cleanup operations. Although weather can impair work efficiency, planning and advance preparation can still facilitate an effective response. For example, arctic clothing is required. The resulting bulk from the arctic clothing hampers worker movement, and cleanup personnel may not be able to tolerate long periods of exposure to the cold. This can be overcome by planning for personnel limitations and providing adequate shelter and opportunities to get warm. To compensate for the lower productivity, additional personnel can be used. One potential problem that could result due to cold weather is equipment failures. However, the use of equipment rated for arctic use, along with the proper equipment operating procedures, can minimize these effects.

Oil spills are also affected by temperature. As temperature decreases, the viscosity of oil increases. Increased viscosity may enhance spill cleanup efforts by slowing the spread of oil. The increasing viscosity at lower temperatures also means that the equilibrium thickness of oil on water is greater than at warmer temperatures. Thus, oil may be recovered with greater efficiency at low temperatures because contaminated areas are smaller and thicker oil facilitates rapid recovery. This is particularly true for recovery with rope mop and weir skimmers.

Wind may affect oil spill cleanup operations. In addition to its effect on worker efficiency through chilling, wind reduces the capability of oil spill containment booms to perform as designed. To contain oil from offshore spills, booms must maintain adequate freeboard to prevent overtopping by waves and must conform to the water surface to prevent oil from escaping underneath the boom. Winds greater than 16 knots will begin to limit the use of containment booms, aerial igniters, and aerial dispersant application.

3.5 LOGISTICAL SUPPORT [18 AAC 75.425(e)(3)(E)]

ExxonMobil will have a logistical support infrastructure for operations with its North Slope partners. Transportation equipment, coordination procedures, and maintenance procedures will be in place under normal operations. Furthermore, ExxonMobil will have contracts for operational logistical support to aid in a spill response through ACS and contracting companies.

ACS
Tactics L-1
through L-4

3.6 RESPONSE EQUIPMENT [18 AAC 75.425(e)(3)(F)]

3.6.1 Equipment Lists

North Slope spill response equipment will be available for oil spill responses at Point Thomson through the ACS charter (see ACS *Technical Manual*, Tactics L-4, L-6, L-8, L-9, and L-10). ACS equipment for Point Thomson will be warehoused at the CPF, pre-staged in containers near the pipeline right-of-way, and stored in containers at the west and east well pads. The location and status of ACS equipment is listed in the Master Equipment List maintained by ACS, which is available upon request. Spill response equipment for Point Thomson will include, at a minimum, equipment listed in Tables 3-10 through 3-12.

ACS
Tactics L-4,
L-6, L-8,
L-9, and
L-10; ACS
Map Atlas

3.6.2 Maintenance and Inspection of Response Equipment

Response equipment will be maintained so that it can be deployed rapidly and in condition for immediate use. The on-site response equipment will be routinely inspected and tested by ACS. In addition, ACS performs routine inspection and maintenance of its response equipment.

ACS Tactic
L-6

ACS has the following USCG OSRO classifications:

- River/Canal - MM, W1, W2, W3
- Inland - MM, W1, W2, W3
- Open Ocean - W2
- Offshore - W2

ACS has fulfilled the equipment maintenance and testing criteria that these classifications require.

3.6.3 Pre-Deployed Equipment

Pre-deployed boom is not planned for Point Thomson.

**TABLE 3-10
SPILL RESPONSE EQUIPMENT**

EQUIPMENT DESCRIPTION	QUANTITY	SIZE	WHEN MOBILIZED¹
<i>Exploration Pad Near Bullen Point</i>			
Anchor Systems	4	-	D
Bird Scare Cannon	2	-	C
Boom, Delta	2000 feet	8-inch x 6-inch	D
Boom, Skor Sorbent	400 LF	4-inch	D
Boom, Skor Sorbent	400 LF	8-inch	D
Connex for Delta Boom	1	8 feet x 20 feet	D
Connex for Sorbent Material	1	8 feet x 20 feet	C
Fold-a-Tanks	2	1500-gallon	D
Propane Cylinders	2	20-lb	C
Skimmer, Drum/Brush Combination	1	36-inch x 24-inch	D
Sorbent Pads 3M	20	36-inch x 36-inch	C
Sorbent Rolls	10	36-inch x 150 feet	C
Tank, Bladder	1	10,000-gallon	D
<i>East Well Pad</i>			
Anchor Systems	4	-	D
Boom, Delta	2000 feet	8-inch x 6-inch	D
Boom, Skor Sorbent	400 LF	4-inch	D
Boom, Skor Sorbent	400 LF	8-inch	D
Connex for Delta Boom	1	8 feet x 20 feet	D
Connex for Sorbent Materials	1	8 feet x 20 feet	C
Sorbent Pads 3M	20	36-inch x 36-inch	C
Sorbent Rolls	10	36-inch x 150 feet	C
<i>West Well Pad</i>			
Anchor Systems	4	-	D
Boom, Delta	2000 feet	8-inch x 6-inch	D
Boom, Skor Sorbent	400 LF	4-inch	D
Boom, Skor Sorbent	400 LF	8-inch	D
Connex for Delta Boom	1	8 feet x 20 feet	D
Connex for Sorbent Materials	1	8 feet x 20 feet	C
Sorbent Pads 3M	20	36-inch x 36-inch	C
Sorbent Rolls	10	36-inch x 150 feet	C
<i>Central Pad</i>			
ATV (6-Wheeler)	1	-	C
Boom Bags, NOFI	2	-	D
Anchor Systems	4	-	D
Bird Scare Cannon	4	-	C
Boom, Delta	2000 feet	8-inch x 6-inch	D
Boom, Fire	950 feet	12-inch x 18-inch	D

**TABLE 3-10 (CONTINUED)
SPILL RESPONSE EQUIPMENT**

EQUIPMENT DESCRIPTION	QUANTITY	SIZE	WHEN MOBILIZED¹
Boom, Light Ocean, Collapsible with Reel	1000 feet	30-inch	D
Boom, Skor Sorbent	400 LF	4-inch	D
Boom, Skor Sorbent	400 LF	8-inch	D
Cam lock Kit	2	Various	D
Chainsaw with Rube Witch	2	36-inch	C
Connex	4	8 feet x 20 feet	C
Connex for Delta Boom	1	8 feet x 20 feet	D
Connex for Fire boom	1	1000 feet	D
Connex for Sorbent Material	1	8 feet x 20 feet	C
Decon Trailer	1	8 feet x 26 feet	C
Discharge Hose	10	2-inch x 50 feet	C
Discharge Hose	10	3-inch x 50 feet	C
Discharge Hose	4	4-inch x 50 feet	C
Desmi Oil Pump (DOP) 160, Pump with Power Pack	2	-	C
Drum Vacuum	1	-	C
Enclosed Snow Machine Trailer	1	8 feet x 24 feet	C
Fold-a-Tanks	3	1500-gallon	D
Gasoline Fuel Trailer	1	500-gallon	C
Generator	2	2 KW	C
Generator	1	5 KW	C
Hand Held GPS	4	N/A	C
Ice Auger with Extensions	2	6-inch	D
Jackhammer (Non-impact) with Attachments	2	40-lb	D
Loader, Bobcat with Attachments/Trailer	1	9 feet x 16 feet	D
Manta Ray Skimmer	2	4 feet x 4 feet	C
Net Launcher with Net	1	-	C
Office Training, Documentation, Miscellaneous		-	D
Propane Cylinders	8	20-lb	C
Pump, Diaphragm (Diesel)	2	3-inch	C
Pump, Peristaltic (Diesel)	2	2-inch	C
Pump, Sandpiper	1	1-inch	C
Pump, Trash (Diesel)	1	4-inch	C
Pump, Trash (Diesel)	2	2-inch	D
Safety and PPE Supplies	Various	Various	C
Skimmer, Drum Vacuum	1	-	D
Skimmer, Drum/Brush Combination	1	4 feet x 4 feet	D
Skimmer, Horizontal Rope Mop System Elec.	1	4-inch	D
Snow Blower	1	-	C
Snow Machine (Long Track) 4-Stroke	2	N/A	C
Sorbent Pads 3M	20	36-inch x 36-inch	C
Sorbent Rolls	10	36-inch x 150 feet	C
Suction Hose	6	3-inch x 20 feet	C
Suction Hose	2	4-inch x 20 feet	C

**TABLE 3-10 (CONTINUED)
SPILL RESPONSE EQUIPMENT**

EQUIPMENT DESCRIPTION	QUANTITY	SIZE	WHEN MOBILIZED¹
Suction Hose	10	2-inch x 20 feet	C
Toilet, Portable, Handicap-Accessible	2	-	C
Tools/Shop Materials and Miscellaneous Equipment	-	Assorted	C
Trimmer Attachment for Bobcat	1	-	D
Tucker Snow Cat with Trailer	1	-	D
Utility Trailer (ATV)	1	-	C
Utility Trailer (Snow Machine)	2	-	C
Warm-up Trailer	1	8 feet x 26 feet	C
Weather Port	1	10 feet x 12 feet	C
Wildlife Capture Kit	1	4-foot x 4-foot Tote	C
Wildlife Hazing Kit	2	4-foot x 4-foot Tote	C

¹ When mobilized on-site. C = Construction; D = Drilling

**TABLE 3-11
OTHER EQUIPMENT POSITIONED AT POINT THOMSON**

EQUIPMENT DESCRIPTION	QUANTITY (MINIMUM QTY OF 1)	WHEN MOBILIZED¹
Enclosed Response Trailer	1	C
Light Plants	2	C
Shop Forklift	1	C
Tioga Heaters, Trailer-Mounted	2	C
Air Compressor for Jackhammers	1	C
30 KW Generator	1	C
Van with Steam Pressure Washer	1	C
Vacuum Truck	2	C
Super Sucker	1	C
Dump Truck	1	C
Snow Melter	1	C
Challenger (or equivalent Loader)	2	C
Grader	1	C

¹ When mobilized on-site. C = Construction; D = Drilling

**TABLE 3-12
ON-WATER MARINE EQUIPMENT POSITIONED AT POINT THOMSON**

EQUIPMENT DESCRIPTION	QUANTITY	SIZE	WHEN MOBILIZED¹
Island Class Vessel with Winter Cover and Trailer	1	25 feet x 12 feet	D
Skimming Vessel/Built-in Recovery System and Onboard Storage and Trailer; <18 in. draft empty, crew of 2	1	32 to 42 feet	D
Shallow Water Boom-Towing Skiff with Trailer	2	20-foot to 24-foot Class	D
Airboat with Trailer	2	20 feet	D
Freighter Airboat with Trailer	1	30 feet	D
Mini-Barge with Trailer	2	40 feet x 15 feet	D

¹ When mobilized on-site. C = Construction; D = Drilling

**3.7 NONMECHANICAL RESPONSE INFORMATION
[18 AAC 75.425(e)(3)(G)]**

Nonmechanical response information is provided in the ACS *Technical Manual, Volume 1*, “B” tactics.

ACS
Tactics B-1
through B-7

The Heli-torch ignition system would be used to ignite thick patches of un-evaporated condensate on water (ACS Tactic B-3). Multiple passes with the ignition would likely be required due to the discontinuities of the slick (ACS Tactic B-3).

Condensate remaining after the burning operation and residue from the burns would drift with the wind. If significant unburned condensate remains, burning in conjunction with the shallow-draft fire booms could be attempted while the oil is drifting.

Remaining oil and residue would eventually collect against the shorelines. It would be recovered with a combination of portable skimmers, manual recovery, and sorbent materials.

ACS Tactic
B-6

**3.8 RESPONSE CONTRACTOR INFORMATION
[18 AAC 75.425(e)(3)(H)]**

ExxonMobil will activate ACS and the North Slope operators to provide the initial personnel and resources required to respond to a large or lengthy spill response. Contact information for ACS is shown in Table 1-2. If additional resources are required, they will be accessed through Master Service Agreements maintained by ACS. A signed copy of ExxonMobil’s Statement of Contractual Terms with ACS for Point Thomson will be provided prior to construction.

3.9 TRAINING AND DRILLS [18 AAC 75.425(e)(3)(I)]

3.9.1 NSSRT Training

The NSSRT consists of workers who volunteer as emergency spill response technicians. Each team member has initial HAZWOPER emergency response training and annual refresher training, which meets or exceeds the requirements in the HAZWOPER regulations,

ACS Tactic
A-3

29 CFR 1910.120(q). Annual requirements for HAZWOPER refreshers, medical physicals, and respiratory fit tests are tracked by ACS through weekly reports from the database (Section 3.9.4, Record Keeping). The NSSRT training program is provided to responders from all production units on the North Slope. Responders are classified into five categories, each with minimum training requirements as noted below. The NSSRT maintains a minimum staffing level designed to ensure response capability in compliance with all North Slope ODPCP response scenarios. The minimum staffing level, illustrated in Table 3-13, represents the largest NSSRT demand for each responder classification derived from all North Slope ODPCP scenarios and therefore exceeds the total personnel requirements of any single scenario.

**TABLE 3-13
NORTH SLOPE SPILL RESPONSE TEAM MINIMUM STAFFING LEVELS**

RESPONDER CLASSIFICATION	MINIMUM NUMBER REQUIRED
General Laborer	48
Skilled Technician	30
Team Leader	12
Vessel Operator-Nearshore	9
Vessel Operator-Offshore	6
Total Responders	105

Active Member Requirements

NSSRT members have completed the following minimum annual training activities to become an active member of the NSSRT:

- 8-hour HAZWOPER refresher certification
- Plan review
- 5 equipment proficiency checks

The NSSRT training program offers weekly classes at each field. The classes emphasize hands-on experience, field exercises, and team-building drills. The courses are selected by the facility ACS Lead Technician with field management and use ExxonMobil, ACS, and external training consultants. The ACS *Technical Manual* lists typical NSSRT training courses. Because of operational time constraints, many of the courses are divided by subject area and taught in the 2- or 3-hour timeframe of an NSSRT meeting. Training and attendance are documented and available for review at ACS Base in Deadhorse. The yearly training schedule is also available at the facility and ACS Base. Current NSSRT training schedules are posted on the ACS website. Descriptions of the five responder categories and training requirements for each are provided in the ACS *Technical Manual*.

ACS Tactic A-4

General Laborer

The General Laborer is a responder with minimal or no field experience in spill response. Duties are associated with mobilization, deployment, and support functions for the response. Support tasks such as deployment of boom sections, assembly of anchors systems, assembly of temporary storage devices, loading and unloading equipment, and decontamination of equipment are typical tasks undertaken by this responder classification.

Responders in this classification must have documentation of compliance with the following minimum training requirements:

- Current 24-hour (or higher) HAZWOPER Certificate
- H₂S Training
- NSTC Academy, including spill prevention and spill notification

Over time, the NSSRT training program will bring each NSSRT member from his or her entry point as a General Laborer to at least the Skilled Technician level.

Skilled Technician

The Skilled Technician is a responder who has experience in spill response activities at a higher level through having received specific training, performed related activities as part of regular employment, or having participated in spill response incidents. Tasks such as the operation of skimmers, powerpacks, and transfer pumps are typical tasks undertaken by this responder. Responders in this classification must have documentation of compliance with the following minimum training requirements:

- Must meet the minimum training requirements for the General Laborer
- Completion of a minimum of 16 hours of training or equivalent experience in any combination of the following categories:
 - Response equipment deployment and use
 - Response tactics and equipment requirements
 - Incident Command System
 - Staging area management and support
 - Boat safety, navigation, or operations
 - Contingency plan familiarization
- Completion of a minimum of 16 hours of actual spill response, response exercise, or field deployment time in any combination of the following positions:
 - Operation of recovery equipment systems
 - Operation of transfer and storage equipment systems
 - Deployment and use of containment systems
 - Decontamination procedures
 - Wildlife hazing, capture, and stabilization
- Minimum of 10 completed equipment proficiency checks

Team Leader

Team Leader roles may include such categories as Task Force Leader, Containment or Recovery Site Team Leader, or Staging Area Manager. A Team Leader is described as an individual who has attended additional training in the actions, responsibilities, and tasks associated with managing portions of an incident. Responders in this classification must have documentation of compliance with the following minimum training requirements:

- Must meet the minimum training requirements for the General Laborer
- Must meet the minimum training requirements for the Skilled Technician
- Current 8-hour (or higher) HAZWOPER Supervisor Certificate
- Minimum of 20 completed equipment proficiency checks

Vessel Operator-Nearshore

Responders qualified as Vessel Operator-Nearshore are tasked with safe operation of vessels less than 30 feet in length. These vessels have a hull design and electronics primarily intended for operation in nearshore environments or occasionally, in conjunction with larger vessels, in an offshore response. Typical duties include, towing and placement of containment booms, setting and tending anchors, and movement of equipment to remote sites. Responders in this classification must have documentation of compliance with the following minimum training requirements:

- Must meet the minimum training requirements for the General Laborer
- Must meet the criteria for any one of the following categories:
 - Completion of the ACS, Captain and Crew, or Boat Safety and Handling Training Programs
 - Completion of 40 hours of equivalent training or experience on vessels smaller or greater than 30 feet, including navigation, charting, vessel electronics and docking and maneuvering procedures
 - Current USCG Operator Uninspected Passenger Vessel, or higher, license
- Completion of Nearshore Vessel proficiency check

Vessel Operator-Offshore

Responders qualified as Vessel Operator-Offshore are tasked with the safe operation of vessels larger than 30 feet in length. These vessels have a hull design and electronics capable of sustaining operations in an offshore environment. Typical duties include the towing of containment booms, working in conjunction with barge containment operations, towing mini-barges, operating skimmers to recover oil, providing ice management support, and providing logistical support to offshore operations. Responders in this classification must have documentation of compliance with the following minimum training requirements:

- Must meet the minimum training requirements of the General Laborer
- Must meet the criteria for any one of the following:
 - Completion of the ACS Captain and Crew Training Program
 - Completion of 40 hours of equivalent training or experience on vessels larger than 30 feet, including navigation, anchoring, vessel electronics, and docking and maneuvering procedures
 - Current USCG 25-ton Near Coastal, or larger, license
- Completion of Offshore Vessel proficiency check

3.9.2 Incident Management Team Training

ACS provides IMT training for its own personnel. Similar training will be provided for the ExxonMobil North Slope IMT personnel. This training includes an introduction to the ICS, ICS position-specific training at section chief level, tabletop exercises, and deployment drills. As new training needs are identified, they are developed and incorporated into the training program. A description of the North Slope IMT training program is provided in the ACS *Technical Manual*.

ACS
*Technical
Manual,
Volume 3,
Section 6;
and Volume
1, Tactic
A-4*

3.9.3 Auxiliary Contract Response Team

ACS maintains and operates an ADEC-approved training and response program to ensure North Slope plan holders have the ability to provide the personnel required to support a long-term response. The program consists of contracts and agreements with numerous Response Action Contractors (RACs) and OSROs and provides assurance that a host of trained and qualified responders are available to respond to oil spills on the North Slope. A list of typical courses is provided in the ACS *Technical Manual* and in Table 3-14.

ACS Tactic
A-4

3.9.4 Record Keeping

ExxonMobil, or its designee, will maintain a database as a record of the courses taken by each employee. Records will be kept for a minimum of three years or for the entire time that the employee is assigned responsibilities under this plan. The database will provide a brief description of the course and the date completed. Current training status of employees will be available on computer printouts or by calling the ExxonMobil office in Anchorage. Full training records of response team members will be maintained and available for inspection at the ACS Base. Contractor companies will keep their own spill response training records.

3.9.5 Spill Response Exercise

ExxonMobil has adopted the National Preparedness for Response Exercise Program (NPREP) guidelines as the structure for the Point Thomson training program and procedures. The NPREP guidelines were developed to establish a workable exercise program that meets the intent of OPA 90 for spill response preparedness. Participation in the NPREP ensures the federal exercise requirements mandated by OPA 90 are met.

Internal Exercises

Internal exercises are those which will be conducted wholly within ExxonMobil and are designed to test the various components of this plan to ensure it is adequate for response to a spill. Internal exercises will include:

- **Quarterly Qualified Individual Notification Drills:** To ensure the QI is able to be reached on a 24-hour basis in a spill response emergency and carry out assigned duties.
- **Annual Spill Management Team Tabletop Exercises:** To ensure personnel are familiar with the contents of this plan, including the DOT Information Summary, the ICS, crisis response procedures, mitigating measures, notification numbers and procedures, and individual roles in the response structure.
- **Semi-Annual Equipment Deployment Exercises:** To ensure internal and contractor-operated response equipment is fully functional and can be deployed in an efficient and productive manner.
- **Annual Unannounced Exercise for NPREP Requirements:** ExxonMobil Emergency Services is responsible for ensuring that an unannounced exercise meeting NPREP requirements occurs annually. The Planning Section Chief is responsible for documenting actions taken during an actual event for NPREP credit if it involves one of the following – use of emergency procedures to mitigate or prevent a discharge or threat of discharge, activation of the field IMT or deployment of spill response equipment
- **Triennial Exercise of Entire Plan including worst case discharge scenario**

**TABLE 3-14
TYPICAL NORTH SLOPE SPILL RESPONSE TEAM
TRAINING COURSES**

CATEGORY	COURSE TITLE
COMMUNICATION	ICS Basic Radio Procedures
DECONTAMINATION	Decontamination Procedures
ENVIRONMENTAL	Environmental Awareness Wildlife Hazing
EQUIPMENT	Basic Hydraulics For Spill Responders Boom Construction and Design Fastanks and Bladders Skimmer Types and Application Snow Machines and ATV Operations 90+ Spill Response Equipment Proficiency Checks
MANAGEMENT	Incident Command System Management and Leadership During an Oil Spill Quarterly Drill and Exercises Staging Area Management
MISCELLANEOUS	Global Positioning System
RESPONSE TACTICS	ISB Nearshore Operations Winter Oil Spill Operations Winter Response Tactics
SAFETY/SURVIVAL	Arctic Cold Weather Survival Arctic Safety HAZWOPER Spill Site Safety Weather Port and Survival Equipment
VESSEL-RELATED	Arctic Cold Water Survival Airboat Operations Boat Safety and Handling Boom Deployment On Rivers Captain/Crewman Vessel Training Charting and Navigation Deckhand/Knot Tying River Response School Swiftwater Survival

With the exception of government-initiated unannounced exercises, the internal exercises will be self-evaluated and self-certified. Documentation, including a description of the exercise, objectives met, and results of evaluations, will be maintained for a minimum of three years. Exercise documentation will be in written form for each exercise, signed by the Point Thomson Environmental Specialist or SHE Lead, and available for review on request.

The Point Thomson SHE Lead, or designee, will be responsible for the scheduling, development, and evaluation of training programs and exercises, and for ensuring that regulatory requirements are met.

External Exercises

External exercises will involve efforts outside of ExxonMobil to test the interaction between ExxonMobil and the response community. The external exercises will also test the plan and the coordination between ExxonMobil and the response community, including the OSRO (ACS), state, federal, and local agencies, and local community representatives.

Point Thomson will participate in an annual Mutual Aid Drill (MAD). In addition to actively participating in the MAD, federal, state, and local agencies are involved in the development and evaluation of the drill. Every year, equipment is deployed at the MAD according to NPREP guidelines. The MAD exercise satisfies the NPREP requirements to exercise all aspects of the response plan at least every three years. Following are the components that are tested through the MAD exercise:

Organizational Design

- Notifications (includes training on 24-hour notifications and reporting to the National Response Center)
- Staff mobilization
- Ability to operate within the response management system described in the plan

Operational Response

- Discharge control
- Assessment of discharge
- Containment of discharge
- Recovery of spilled material
- Protection of economically and environmentally sensitive areas
- Disposal of recovered product

Response Support

- Communications
- Transportation
- Personnel support
- Equipment maintenance and support
- Procurement
- Documentation

3.10 PROTECTION OF ENVIRONMENTALLY SENSITIVE AREAS [18 AAC 75.425(e)(3)(J)]

Priority protection sites, sensitivities, surface water flow directions, wildlife protection strategies, and natural resources are described in the ACS *Technical Manual*, and are subject to confirmation by the resource agencies.

ACS Maps
91, 94 to
105; ACS
TM Tactics
W-1
through
W-6

3.11 ADDITIONAL INFORMATION [18 AAC 75.425(e)(3)(K)]

Not applicable.

3.12 BIBLIOGRAPHY [18 AAC 75.425(e)(3)(L)]

- Alaska Clean Seas. 2001. *Alaska Clean Seas Technical Manual*, Volumes 1, 2, and 3. Prudhoe Bay, Alaska.
- Alaska Drilling and Wells. 2002. *Arctic Well Control Contingency Plan*. BP Exploration (Alaska), Inc.
- Alaska Regional Response Team. 1999. *Alaska Federal/State Preparedness Plan for Response to Oil and Hazardous Substance Discharges/Releases*, Annex F, Appendix I.
- Alyeska Pipeline Service Company. 1998. *Prince William Sound Tanker Oil Discharge Prevention and Contingency Plan*, Part 3, SID#1, Section 7.
- ANSI/ASME B31G-1984, *Manual for Determining the Remaining Strength of Corroded Pipelines, A Supplement to ANSI/ASME B31 Code for Pressure Piping*.
- Atwater, S.G. 1991. *1990 Endicott Environmental Monitoring Program Final Report: Ice Break-up and Freeze-up*. Prepared by SAIC for the U.S. Army Corps of Engineers, Anchorage AK.
- BP Exploration (Alaska) Inc. and Phillips Alaska, Inc. 2001. *North Slope Environmental Field Handbook*. 80 pages.
- Dames & Moore, 1983. Point Thomson Development, Alaska 1983 Hydrology Program. Prepared for Exxon Company, U.S.A., Thousand Oaks, CA.
- DF Dickins Associates Ltd., 1984. *Alaskan Beaufort Sea Ice Atlas*. Prepared for SOHIO Petroleum Company, Dallas TX.
- Dickins, D.F., Hearon G. and K. Vaudrey. 2001. *Sea Ice Overflow in Stefansson Sound, Alaskan Beaufort Sea*. In: Proceedings 16th International Conference on Port and Ocean Engineering Under Arctic Conditions, Vol. I, Ottawa, pp. 193-202.
- EPA. 1995a. *SCREEN3 Model User's Guide*. U.S. Environmental Protection Agency, Office of Air Quality Planning and Standards, Emissions, Monitoring, and Analysis Division, Research Triangle Park, NC, September 1995.
- EPA. 1995b. *Compilation of Air Pollutant Emission Factors, AP-42, Fifth Edition, Volume I: Stationary Point and Area Sources*. U.S. Environmental Protection Agency, Research Triangle Park, NC, January 1995.
- ExxonMobil Development Company. 2002. *Drilling OIMS Manual, Second Edition*. Houston, Texas, January 2002.
- ExxonMobil Development Company. 2001. *Emergency Response Guide*. Houston, Texas, April 2001.
- ExxonMobil Development Company. 2000. *Safety Manual*. Houston, Texas, September 2000.
- Hydrocon Engineering (Continental) LTD., 1982. Point Thomson Development Hydrologic Studies. Prepared for Exxon Company, U.S.A., Los Angeles, CA.
- LaBelle, J.C. and J.L. Wise, 1983. *Alaska Marine Ice Atlas*. Produced by the Arctic Information and Data Center, University of Alaska, Anchorage AK.

North Slope Unified Operating Procedures, May 29, 1999.

Phillips Alaska, BP Exploration (Alaska), Inc., and Alyeska Pipeline Service Company. 2002. *Alaska Safety Handbook*. 196 pages.

Titan. 2003. *SCIPUFF Model*. Information available at <http://www.titan.com/appliedtech/Pages/TRT/scipuff/scipuff.htm>. Titan Research and Technology, Princeton, NJ.

U.S. Army, Corps of Engineers. June 1999. *Environmental Impact Statement: Beaufort Sea Oil and Gas Development/Northstar Project. Vol. III Chapter 5 - Affected Physical Environment*.

Vaudrey, K. June 27, 1998. *Broken Ice Periods for Selected Production Sites Along the Alaskan Beaufort Sea*. Memo from Vaudrey & Associates, Inc. to B. McKenzie, BP Exploration Alaska, Anchorage (unpublished).

Vaudrey, K., 1985a. *1984 Breakup Study of the Alaskan Beaufort and Upper Chukchi Seas. AOGA Project 274*, Vaudrey & Associates, Inc., San Luis Obispo, CA.

Vaudrey, K., 1985b. *1984 Freezeup Study of the Alaskan Beaufort and Upper Chukchi Seas. AOGA Project 282*, Vaudrey & Associates, Inc., San Luis Obispo, CA.

Vaudrey, K., 1985c. *Historical Summary of 1980-82 Freeze-up Seasons and 1981-83 Break-up Seasons* (Vol. 1 of 2). Prepared for Chevron, Marathon, Phillips, Shell and SOHIO. AOGA Project 275, by Vaudrey & Associates, Inc., San Luis Obispo, CA.

Vaudrey, K., 1986a. *1985 Breakup Study of the Alaskan Beaufort and Upper Chukchi Seas. AOGA Project 319*, Vaudrey & Associates, Inc., San Luis Obispo, CA.

Vaudrey, K., 1986b. *1985 Freezeup Study of the Alaskan Beaufort and Upper Chukchi Seas. AOGA Project 327*, Vaudrey & Associates, Inc., San Luis Obispo, CA.

Vaudrey, K., 2000. Part II: *Description of the Ice Conditions*. In: *Oil Spills in Ice Discussion Paper*. Prepared by DF Dickins Associates Ltd., Vaudrey & Associates Inc., and SL Ross Environmental Research Limited for Alaska Clean Seas, Prudhoe Bay, AK.

STATEMENT OF CONTRACTUAL TERMS

AS REQUIRED UNDER AS 46.04.30, AS 46.04.035 and 18 AAC 75.445(l)(1) in fulfillment of a requirement for registration of primary response action contractors and for approval of an Oil Discharge Prevention and Contingency Plan.

PLAN TITLE: Point Thomson Oil Discharge Prevention and Contingency Plan

PLAN HOLDER: ExxonMobil Development Company on behalf of Exxon Mobil Corporation

This statement is a certification to the Alaska Department of Environmental Conservation summarizing the contract between ExxonMobil the oil discharge prevention and contingency plan holder (hereinafter "PLAN HOLDER") and Alaska Clean Seas, the oil spill primary response action contractor or a holder of an approved oil discharge prevention and contingency plan under contract (hereinafter "CONTRACTOR"), executed _____, and the original of which is located at Alaska Clean Seas, Spine Road, Prudhoe Bay, Alaska 99734-0022, as evidence of the PLAN HOLDER's access to the containment, control and/or cleanup resources required under standards at AS 46.04.030 and 18 AAC 75.495. The PLAN HOLDER and the CONTRACTOR attest to the Department that the provisions of this written contract clearly obligate the CONTRACTOR to:

- (A) provide the response services and equipment listed for the CONTRACTOR in the contingency plan;
- (B) respond if a discharge occurs;
- (C) notify the PLAN HOLDER immediately if the CONTRACTOR cannot carry out the response actions specified in this contract or the contingency plan;
- (D) give written notice at least 30 days before terminating this contract with the PLAN HOLDER;
- (E) respond to a Department-conducted discharge exercise required of the PLAN HOLDER; and
- (F) continuously maintain in a state of readiness, in accordance with industry standards, the equipment and other spill response resources to be provided by the CONTRACTOR under the contingency plan.

I hereby certify that as a representative of the PLAN HOLDER, I have the authority to legally bind the PLAN HOLDER in this matter. I am aware that false statements, representations, or certifications may be punishable as civil or criminal violations of law.

Signature Date

Name: Randy F. Buckley, Project Manager

Title: _____

For: ExxonMobil Development Company on behalf of Exxon Mobil Corporation
PLAN HOLDER

I hereby certify that as a representative of the CONTRACTOR, I have the authority to legally bind the CONTRACTOR in this matter. I am aware that false statements, representations, or certifications may be punishable as civil or criminal violations of law.

Signature Date

Name: Brad Hahn

Title: General Manager

For: Alaska Clean Seas
CONTRACTOR

TABLE OF CONTENTS FOR SECTION 3

3.	SUPPLEMENTAL INFORMATION [18 AAC 75.425(e)(3)]	3-1
3.1	FACILITY DESCRIPTION AND OPERATIONAL OVERVIEW [18 AAC 75.425(e)(3)(A)]	3-1
	3.1.1 Facility Ownership, Location, and General Description.....	3-1
	3.1.2 Facility Storage Containers [18 AAC 75.425(e)(3)(A)(i) and (ii)].....	3-2
	3.1.3 Transfer Procedures [18 AAC 75.425(e)(3)(A)(v)].....	3-2
	3.1.4 Description and Operation of Production Facilities [18 AAC 75.425(e)(3)(A)(vi)].....	3-2
3.2	RECEIVING ENVIRONMENT [18 AAC 75.425(e)(3)(B)].....	3-11
	3.2.1 Water and Weather.....	3-11
	3.2.2 Sea Ice	3-18
	3.2.3 Potential Routes of Discharges [18 AAC 75.425(e)(3)(B)(i)].....	3-27
	3.2.4 Estimate of RPS Volume to Reach Open Water [18 AAC 75.425(e)(3)(B)(ii)] ..	3-27
3.3	COMMAND SYSTEM [18 AAC 75.425(e)(3)(C)]	3-28
3.4	REALISTIC MAXIMUM RESPONSE OPERATING LIMITATIONS [18 AAC 75.425(e)(3)(D)]	3-29
3.5	LOGISTICAL SUPPORT [18 AAC 75.425(e)(3)(E)].....	3-30
3.6	RESPONSE EQUIPMENT [18 AAC 75.425(e)(3)(F)]	3-30
	3.6.1 Equipment Lists.....	3-30
	3.6.2 Maintenance and Inspection of Response Equipment.....	3-30
	3.6.3 Pre-Deployed Equipment	3-30
3.7	NONMECHANICAL RESPONSE INFORMATION [18 AAC 75.425(e)(3)(G)].....	3-34
3.8	RESPONSE CONTRACTOR INFORMATION [18 AAC 75.425(e)(3)(H)]	3-34
3.9	TRAINING AND DRILLS [18 AAC 75.425(e)(3)(I)]	3-34
	3.9.1 NSSRT Training	3-34
	3.9.2 Incident Management Team Training	3-37
	3.9.3 Auxiliary Contract Response Team.....	3-38
	3.9.4 Record Keeping.....	3-38
	3.9.5 Spill Response Exercise	3-38
3.10	PROTECTION OF ENVIRONMENTALLY SENSITIVE AREAS [18 AAC 75.425(e)(3)(J)]	3-40
3.11	ADDITIONAL INFORMATION [18 AAC 75.425(e)(3)(K)]	3-40
3.12	BIBLIOGRAPHY [18 AAC 75.425(e)(3)(L)].....	3-41

LIST OF FIGURES

3-1	Simplified Flow Diagram	3-5
3-2	Three Train Injection Case.....	3-6
3-3	Wind Direction Frequencies At Barter Island	3-12
3-4	General Location Map Showing The Ice Discussion Area	3-19
3-5	Landsat 4 Image June 13, 1986, Showing Coastal Ice Conditions Approximately 48 Hours Following Floodwater Drainage From The Major Rivers	3-22
3-6	Deteriorated Ice In The Lagoon Areas	3-23
3-7	Landsat 7 July 23, 2001, Showing Open Water Along The Coast From Brownlow Point To West Dock	3-24

LIST OF TABLES

3-1	Condensate and Reservoir Characteristics	3-1
3-2	Well Counts	3-7
3-3	Summary Of Condensate Production Pipelines.....	3-8
3-4	Barter Island Average Ambient Temperature (°F).....	3-11

3-5	Prudhoe Bay Yearly Probability of Temperature Occurrence	3-12
3-6	Mean and Instantaneous Wind	3-13
3-7	Climate Data for Yukon Gold Ice Pad Area (Inland) and Barter Island (Coastal)	3-13
3-8	Oceanographic Data Summary	3-14
3-9	Historical Break-Up Sequence for the Canning River, 1974-1990 (Atwater 1991)	3-22
3-10	Spill Response Equipment	3-31
3-11	Other Equipment Positioned at Point Thomson	3-33
3-12	On-Water Marine Equipment Positioned at Point Thomson	3-34
3-13	North Slope Spill Response Team Minimum Staffing Levels.....	3-35
3-14	Typical North Slope Spill Response Team Training Courses	3-39

4. BEST AVAILABLE TECHNOLOGY [18 AAC 75.425(e)(4)]

This section discusses the best available technology (BAT) requirements in 18 AAC 75.425(e)(4)(A), (B), and (C) to address technologies not subject to response planning standards or performance standards in 18 AAC 75.445(k)(1) and (2). The discussion of each technology covers the requirement to analyze applicable technologies and to provide a justification that the Point Thomson technology is BAT. The spill prevention and response equipment for Point Thomson meets the BAT requirements because it meets the response planning standards and performance standards in 18 AAC 75.

4.1 COMMUNICATIONS [18 AAC 75.425(e)(4)(i)]

The BAT analysis of the communication systems for spill responses at Point Thomson is described in the ACS *Technical Manual, Volume 1*.

ACS Tactic
L-11A

4.2 SOURCE CONTROL [18 AAC 75.425(e)(4)(A)(i)]

4.2.1 Well Source Control

ExxonMobil believes surface intervention constitutes BAT for source control of a blowout (see Table 4-1). This technology supplements the existing well source control BAT through the addition of voluntary well ignition in the event of an unrestricted blowout. Voluntary ignition for the Point Thomson gas condensate field will provide an effective means of discharge control of liquid hydrocarbons to the environment without violating air quality standards and will create a safer working environment for subsequent surface intervention operations to secure the well.

Surface intervention and relief well drilling will be two methods used to regain control of a well blowout after the primary (mud weight) and secondary (BOPE) barriers have been breached. Surface intervention includes reestablishing the primary barrier (circulating or bullheading fluids or a dynamic kill) and/or installing or repairing the secondary barrier (by well capping or by restoring the integrity of existing BOPE).

The severity of the well control event dictates the surface intervention response. In the event of a minor flow, control methods could be as simple as sealing a leak or repairing an equipment component, and voluntary well ignition would not be necessary. In the event of substantial flow, voluntary ignition will be used for immediate source control and appropriate surface intervention methods would follow. Blowout ignition as planned here is a source control technique for spill prevention purposes rather than a means of cleaning up the oil after it has reached the surface.

Relative to its alternatives, well ignition is expected to yield net environmental benefits, particularly where blowout condensate would otherwise enter open water. Igniting a blowout will minimize the amount of condensate that reaches the ground or water surface. The combusted condensate aerial plume will not contaminate the surface as an oil spill. Under the conditions of a blowout at Point Thomson, the smoke, including combustion gases and soot particulates, is expected to have no effects on public health or wildlife (see the public health effects in the Alaska Regional Response Team's "*In Situ* Burning Guidelines for Alaska" in the *Federal/State/Tribal Unified Plan for Alaska*).

**TABLE 4-1
BEST AVAILABLE TECHNOLOGY ANALYSIS
WELL BLOWOUT SOURCE CONTROL**

BAT EVALUATION CRITERIA	EXISTING METHOD: SURFACE INTERVENTION TOOL KIT INCLUDING WELL IGNITION	ALTERNATE METHOD: RELIEF WELL DRILLING
<p>AVAILABILITY: Whether technology is best in use in other similar situations or is available for use by applicant</p>	<p>Surface intervention is in use globally. Surface intervention, well ignition, and well control equipment fit for this purpose is located on the North Slope and at Point Thomson. Additional equipment can be on location within 24 to 48 hours.</p>	<p>Relief well drilling equipment (rigs, down hole tools, etc.) is available though not widely used. If two rigs are used at Point Thomson, one will serve as the relief rig for the other. If only one rig is used at Point Thomson, an agreement will be arranged with other operators for a relief well rig. Mobilization time could be substantial depending on time of year.</p>
<p>TRANSFERABILITY: Whether each technology is transferable to applicant's operations</p>	<p>Equipment is currently available on the North Slope, at Point Thomson, or on retainer via contract. Experienced well control specialists familiar with the technology and techniques are under contract to ExxonMobil.</p>	<p>Relief well drilling technology is mature. The tools and techniques have been perfected over time. ExxonMobil has experience in their application.</p>
<p>EFFECTIVENESS: Whether there is a reasonable expectation each technology will provide increased spill prevention or other environmental benefits</p>	<p>Excluding blowouts which stop flowing through natural causes (bridging, depletion, etc.), surface intervention is clearly effective since the technique is responsible for controlling most of the remaining blowouts (see description below in this section). When surface intervention is supplemented with voluntary well ignition the spill volumes and environmental impact are minimized. Voluntary ignition as a discharge control method is extremely effective when the well fluid is highly combustible such as a gas condensate.</p>	<p>Successful relief well drilling for blowout control has been thoroughly documented in the industry; however, this technique has only controlled the flow in 4 percent of all blowouts (see description below in this section). Although a relief well is effective, it is the longest duration source control and pollution mitigation measure because new locations must be prepared, rigs mobilized, and the relief well drilled to intersect the original blowout well.</p>
<p>COST: The cost to the applicant of achieving BAT, including consideration of that cost relative to the remaining years of service of the technology in use by the applicant</p>	<p>Equipment fit for this purpose is already owned and/or under long-term contract. Surface intervention requires the maintenance of open-end contracts with trained specialists to implement well control/capping operations. Voluntary ignition of blowout fluids will significantly reduce cleanup costs. The cost for 15 days for surface intervention efforts is substantially less than the cost for relief well drilling.</p>	<p>Time and cost of permitting, on-site construction, well planning and executing relief wells is estimated to be at least an order of magnitude larger than the cost of surface intervention.</p>
<p>AGE AND CONDITION: The age and condition of technology in use by the applicant</p>	<p>Surface intervention is established technology which has been improved since its frequent application during the Iraq-Kuwait conflict in early the 1990s.</p>	<p>Relief well drilling technology is similar to current methods used to drill/complete North Slope wells.</p>
<p>COMPATIBILITY: Whether each technology is compatible with existing operations and technologies in use by the applicant</p>	<p>Technology is compatible and applied at surface (no sensitivity to well type).</p>	<p>Technology is compatible though potentially sensitive to blowout well types (ERD, remote locations, etc.). Relative wellbore-location uncertainty on high departure wells may result in problems intersecting the target wellbore.</p>
<p>FEASIBILITY: The practical feasibility of each technology in terms of engineering and other operational aspects</p>	<p>Method is feasible with all drilling operations. Applied at surface - no sensitivities to well type (ERD, remote locations, etc.). Prior proven success in onshore and offshore environments. Demonstrated high success rate in historical well control efforts.</p>	<p>Method feasibility contingent upon geographical access near area of blowout. Lack of year-round access to some locations (offshore Beaufort Sea) limits application. Very little evidence of successful application of relief well drilling as the primary mitigation measure of control. Relief wells may be preferred response method in some rarely occurring well control events.</p>
<p>ENVIRONMENTAL IMPACTS: Whether other environmental impacts of each technology, such as air, land, water pollution, and energy requirements, offset any anticipated environmental benefits</p>	<p>Technology provides the best-proven opportunity to quickly reduce environmental impacts. Voluntary ignition of the blowout well (if applied) will substantially reduce the spilled liquid volume. The duration is significantly less than conventional alternative technologies.</p>	<p>Technology provides additional exposure and environmental risks during application. Technology application may be seasonally limited, leading to durations of 36 to 180 days. Relief wells may require additional gravel placement and mobilization or demobilization affects on the local environment. Drilling a relief well is accompanied by the additional risk of a second well control event.</p>

The authority to ignite a well blowout will be delegated to the Drilling Supervisor on the rigsite. It will be his responsibility to ensure the safety of personnel and to assess the situation.

The Drilling Supervisor will determine if voluntary ignition is necessary either from a safety or an environmental standpoint.

The rationale for acceptance of surface intervention as BAT is provided in the following discussion.

Surface Intervention

Over the past decade surface intervention techniques have been developed and proven to be both efficient and effective in regaining control of damaged wells and reducing the associated environmental impacts. Significant improvements in surface intervention techniques and procedures have been developed by a variety of well-control specialist companies around the world. Their use was instrumental in controlling the Kuwaiti fires and mitigating the associated environmental damage.

Surface intervention operations are highly dependent on the severity of the well control situation. ExxonMobil has fixed-wing aircraft to mobilize specialized personnel and all equipment (e.g., capping stack, cutting tools) to Point Thomson within 1 to 2 days after notification.

ExxonMobil has access to an inventory of fire-fighting equipment permanently warehoused on the North Slope. The equipment includes two 6,000-gpm fire pumps, associated piping, lighting, transfer pumps, Athey wagons, specialized nozzles, and fire monitor shelters listed in Table 1-7. Prior to drilling startup, a comprehensive list of required equipment, which includes equipment on the North Slope and elsewhere, will be prepared. This equipment represents a standard array of fire-fighting and well control equipment normally mobilized by well control specialists in a blowout event. Maintaining much of this equipment in-place on the North Slope significantly minimizes the time required to mobilize the required well control equipment in an actual blowout event. Other equipment for surface intervention operations will be on location at Point Thomson.

Surface intervention is both compatible and feasible with all drilling operations because the technology is applied at the surface. There are no sensitivities to well types (e.g., extended reach drilling, horizontal drilling) or location (e.g., remote, island). Surface intervention techniques have been applied both on land and at offshore locations to regain well control and have historically proven successful in regaining well control much faster than the more time-consuming alternative of drilling a relief well.

Drawing on a database of more than 1,000 blowouts from US Outer Continental Shelf (OCS) and onshore Texas wells, Skalle et al. (SPE 53974), report findings which indicate that surface intervention is generally more successful in rapidly regaining well control than drilling a relief well. If the roughly 5 percent of the wells that are missing data regarding the kill method are ignored, surface intervention was the kill method employed on 69 percent of all the remaining blowouts. Bridging/depletion and relief wells were the mechanisms in 27 and 4 percent of the well kills, respectively. If the data are restricted to only those wells in which either relief wells or surface intervention was the kill method, 95 percent of the wells were controlled by surface intervention and only 5 percent of the blowouts were controlled with relief wells. There can be no doubt that surface intervention techniques (BOPs, capping, mud, cement, and installation of equipment) are proven methods that are used in controlling the majority of well blowouts. Surface intervention is usually the preferred control method. Only in

rare cases in which casing cannot be accessed by excavation or when entry to the wellbore is blocked will a relief well be required. However, our plan includes pursuing a relief well in conjunction with the surface intervention. It is worth noting that in Kuwait where surface wellhead equipment had been severely damaged by explosives, no relief wells were attempted or necessary.

ExxonMobil maintains an operating agreement with well control specialists who can assist in the intervention and resolution of well control emergencies. Maintaining an open contract with well control specialists is a minimal annual cost. Any additional services required during an actual response would be provided at previously agreed rates.

In a well blowout event, surface intervention operations would commence with ExxonMobil's activation of well control specialists and mobilization of key personnel and equipment. Dynamic and surface well control methods would continue to be attempted, if safe to do so. Once surface intervention is selected, safe re-entry to the wellhead area would be established and rig equipment moved to allow safe access. If the rig moving system were unavailable or inactive, then heavy bulldozers, block and tackle, and/or cranes would remove the rig from the wellhead area. Once safe access is regained, intervention operations would commence.

Data from MMS and SINTEF Civil and Environmental Engineering (Norway) indicate that surface intervention technologies provide the shortest duration and most effective option for regaining well control and minimizing environmental impacts once initial control measures have failed.

In summary, ExxonMobil believes surface intervention to be BAT because it is the most expedient and effective method for restoring well control, and that voluntary ignition in the case of a major blowout is the best means of discharge control to protect the environment and to create a safer working environment for the well control team.

Relief Well Drilling

Relief well drilling is an alternative method to surface intervention. Relief well drilling has historically been accepted as the blowout mitigation method that would be applied on the North Slope. Relief well drilling technology is compatible with North Slope drilling operations although it may be sensitive to both the well location and well types.

If two rigs are used at Point Thomson, one of the two rigs will function as the relief rig. Otherwise the rig will be transported from elsewhere in Alaska or Canada. Downhole and surface equipment (e.g., tubulars, wellheads) to support relief well drilling operations is available.

Although relief well drilling has often been proposed as a blowout response method, it has been attempted only once as a mitigation measure to control blowouts on the North Slope (i.e., ARCO Cirque blowout, 1992). In the 1992 Cirque case, well control was regained by a combination of surface intervention techniques with an assist from natural bridging before the relief well reached total depth.

Methods for drilling a relief well are similar to current methods used to drill and complete North Slope production wells today. Advances in directional drilling technology allow more precise wellbore placement and increase the likelihood of success of a relief well. Unfortunately, relief well attempts will be more sensitive to well locations and/or well types. For extended reach wells or remote locations with limited access, relief well drilling will be

both challenging and time consuming, thereby adding to the overall environmental impact and volume spilled during a blowout.

Government and industry data (Scandpower Report 27.83.01) indicate that of the 117 total North Sea and Gulf of Mexico blowouts between 1980 and 1999, only four relief wells were drilled to regain control. For the 26 “deep” blowouts below surface casing during the same time period, no relief wells were needed or even attempted. In each of the “deep” blowouts, well control was regained through conventional surface intervention or by natural means (formation bridging).

Selecting an appropriate surface location is critical to relief well placement. If surface locations are not near the blowout location, the relief well can often pose significant challenges (e.g., tortuous directional drilling or extended reach drilling) to reaching the target formations in the blowout well. Optimally, a relief location will be positioned to minimize drilling time and complexity to reach target formation, to provide a suitable working surface to support drilling operations, and will be away from the blowout plume and associated explosion hazards. Optimum surface locations are rarely available on the North Slope, and therefore, relief well drilling is often the least desirable option. Fortunately at Point Thomson it may be possible to use existing locations from previous exploration wells.

Relief well drilling to a “deep” blowout below surface casing can be a time-consuming and costly process. If access to the blowout location is unavailable, alternative relief well locations must be found and/or constructed (e.g., access roads, gravel pads in the summer, ice pads in the winter). After permitting, site construction, well planning, and rig mobilization, the relief well must still be drilled. On the North Slope, the time needed to drill an onshore relief well is often estimated in the 36- to 90-day range. Drilling an offshore relief well could take significantly longer (up to 180 days) depending on the ice and water conditions and weather restrictions. These lengthy timelines add to the overall environmental impact (spill volume) of the blowout. Based on historical data (Scandpower Report 27.83.01), it is estimated that between 93 and 97 percent of blowouts would be under control by other means by the time the relief well drilling rig could be mobilized.

Relief well drilling success is dependent on access to an area near the blowout well and directional drilling techniques to ensure blowout well intersection. Lack of year-round road access and pad availability significantly impact estimated relief well timelines. Relief well planning will consider use of exploration pads.

Relief wells take the longest time of any alternative to effectively regain well control. In addition to the longer blowout duration, the relief well itself introduces additional environmental risks. Some old gravel pads will be retained for relief wells; however, if access to a site near the blowout well is limited, a new gravel or ice pad must be quickly constructed. If gravel is required there will be an impact to the tundra where gravel is placed. During equipment mobilization and relief well drilling operations, additional risks of spills and tundra impacts are posed. During the drilling of the relief well itself, the risk of a second well control event is introduced.

Conclusion

ExxonMobil maintains that surface intervention, supplemented by voluntary ignition when needed, constitutes BAT for well source control. Table 4-1 summarizes surface intervention as BAT for a blowout. Historical evidence clearly indicates that surface intervention has greater reliability and application for well control than relief well drilling. Surface intervention

response times account for at least a 50 percent reduction in blowout durations when compared to those for relief well drilling.

4.2.2 Pipeline Source Control

Condensate Export Pipeline Source Control

Source control procedures for a spill from the condensate export pipeline, as required by 18 AAC 75.425(e)(1)(F)(i), involve the placement of automatic valves at CPF to stop the flow of liquids into the Point Thomson condensate export pipeline, and at the Badami tie-in.

There are two technology options for the automatic valves: actuated ball valves and actuated gate valves. Both valve options, when installed in new condition, are similar in terms of availability, transferability, cost, compatibility, and feasibility. In terms of effectiveness, ball valves typically have slightly faster closure times than gate valves. As required by 18 AAC 75.055(b), the flow of oil or product/gas can be completely stopped by these valves within one hour after a discharge has been detected. The valve closure time for these types of valves is usually 2 to 3 minutes. See Table 4-2 for BAT analysis for source control for the export pipeline.

Gathering Line Source Control

The high-pressure gathering lines, which will transport full wellstream production from the East and West Drilling Pads to the CPF, will each be connected to a manifold at their respective pads. The pipeline source control procedures for the gathering lines include the actuation of shutoff valves in each of the well production lines tying into the manifold. The valves on each well line will shut down wells and close production flowlines. Actuated valves will also be placed in the gathering lines at the CPF. Both sets of actuated valves will be provided to stop the flow of full wellstream gas and liquids into the gathering lines. Table 4-3 shows the BAT analysis for the gathering and well oil line source control.

4.2.3 Tank Source Control

Oil storage tank overflow control BAT analysis involves tank source control and tank liquid level determination. The BAT review for source control focuses on technology to stop the flow of product into the tank (Table 4-4). Source control procedures involve emergency shutdown valves on the fill line. Tank source control BAT for a ruptured tank is secondary containment or a double-wall tank, also shown on Table 4-4.

Automatic valves are provided on process and large storage tanks that may be subject to continuous filling or draining as part of the production process. Automatic valves are considered BAT for such tanks because they provide the most effective means to stop the flow of oil into tanks whose levels are constantly changing (Table 4-4). However, the facility operator will also have the ability to manually close tank valves if low or high level alarms indicate a potential problem. The valve type selected for this service is activated by a liquid-level detector (float switch or equivalent), and is the best available technology.

Manual valves will be used on regulated oil storage tanks that are filled infrequently. The tanks will be subject to fluid transfer procedures (Appendix A) for tank filling and will require the presence of an operator during filling operations. Tank spill root-cause analysis indicates that source control during filling of tanks is best achieved by the on-site presence of an operator who can immediately stop a tank-filling operation if a potential problem occurs. For this reason, manual valves are considered BAT for infrequently filled tanks (Table 4-4). Tanks

will be equipped with a high-level alarm with local audible alarm to notify the Operator when a certain level of liquid in the tank is reached during tank filling operations.

**TABLE 4-2
BEST AVAILABLE TECHNOLOGY ANALYSIS SOURCE CONTROL ON CONDENSATE
EXPORT PIPELINE**

BAT EVALUATION CRITERIA	PROPOSED METHOD: AUTOMATIC VALVES (BALL OR GATE)	ALTERNATE METHOD: CHECK VALVES	ALTERNATE METHOD: VERTICAL LOOPS
AVAILABILITY: Whether technology is best in use in other similar situations or is available for use by applicant	Technology exists and is common in pipeline systems.	Technology exists and is common in pipeline systems.	Technology exists.
TRANSFERABILITY: Whether each technology is transferable to applicant's operations	This technology is transferable to this pipeline.	This technology is transferable to this pipeline.	This technology may be transferable to the pipeline to reduce spill volumes.
EFFECTIVENESS: Whether there is a reasonable expectation each technology will provide increased spill prevention or other environmental benefits	An effective means of isolating pipeline system quickly.	Less effective means to reduce spillage where terrain profile limits oil drainage.	An effective means to reduce spill volumes by creating natural drainage breaks.
COST: The cost to the applicant of achieving BAT, including consideration of that cost relative to the remaining years of service of the technology in use by the applicant	Approximately \$200,000 per valve.	Approximately \$50,000 per valve.	Possibly the same cost as automatic valves.
AGE AND CONDITION: The age and condition of technology in use by the applicant	Method is current.	Method is current.	Application of existing technology to new use.
COMPATIBILITY: Whether each technology is compatible with existing operations and technologies in use by the applicant	Compatible with the pipeline system and sites selected based on reducing release volumes.	Compatible with the pipeline system.	Compatible with the pipeline system but have to be engineered to ensure expansion and forces are within acceptable limits.
FEASIBILITY: The practical feasibility of each technology in terms of engineering and other operational aspects	Method is feasible and is commonly used.	Is feasible to install.	Feasible to install but has not been proven. There are still some concerns over operational aspects.
ENVIRONMENTAL IMPACTS: Whether other environmental impacts of each technology, such as air, land, water pollution, and energy requirements, offset any anticipated environmental benefits	There is a possibility that leaks or drips could occur on the valves, but these can be minimized by proper maintenance for the valve.	There is a possibility that leaks or drips could occur on the valves. Check valves are a major source of pipeline leaks.	No additional impacts.

**TABLE 4-3
BEST AVAILABLE TECHNOLOGY ANALYSIS
GATHERING AND WELL OIL LINE SOURCE CONTROL**

BAT EVALUATION CRITERIA	PROPOSED METHOD: ACTUATED VALVES ON WELL FLOWLINES AND GATHERING LINES AT CPF	PROPOSED METHOD: MANUAL SHUTDOWN OF WELLS	ALTERNATE METHOD: ACTUATED VALVE ON GATHERING LINE ONLY
AVAILABILITY: Whether technology is best in use in other similar situations or is available for use by applicant	Technology exists and is common in pipeline systems.	Technology exists and is common in pipeline systems.	Technology exists and is common in pipeline systems.
TRANSFERABILITY: Whether each technology is transferable to applicant's operations	This technology is transferable to the pipelines.	This technology is transferable to the pipelines.	This technology is transferable to the pipelines.
EFFECTIVENESS: Whether there is a reasonable expectation each technology will provide increased spill prevention or other environmental benefits	An effective means of isolating pipeline systems quickly.	Less effective for rapid isolation of well and gathering lines.	Less effective for isolation of well and gathering lines.
COST: The cost to the applicant of achieving BAT, including consideration of that cost relative to the remaining years of service of the technology in use by the applicant	Less than \$500,000.	Less than \$500,000.	Approximately \$500,000 for a 16-inch corrosion resistant alloy rated to 10,000 psi.
AGE AND CONDITION: The age and condition of technology in use by the applicant	The valves would be new upon installation.	The valves would be new upon installation.	The valves would be new upon installation.
COMPATIBILITY: Whether each technology is compatible with existing operations and technologies in use by the applicant	Compatible with the pipeline system and sites selected based on reducing release volumes.	Compatible with the pipeline system.	Compatible with the pipeline system.
FEASIBILITY: The practical feasibility of each technology in terms of engineering and other operational aspects	Method is feasible.	Method is feasible.	Method is feasible.
ENVIRONMENTAL IMPACTS: Whether other environmental impacts of each technology, such as air, land, water pollution, and energy requirements, offset any anticipated environmental benefits	There is a possibility that leaks or drips could occur on the valves, but these can be minimized by proper maintenance and visual surveillance.	There is a possibility that leaks or drips could occur on the valves, but these can be minimized by proper maintenance and visual surveillance.	There is a possibility that leaks or drips could occur on the valves, but these can be minimized by proper maintenance and visual surveillance.

**TABLE 4-4
BEST AVAILABLE TECHNOLOGY ANALYSIS TANK SOURCE CONTROL**

BAT EVALUATION CRITERIA	PROPOSED METHOD: AUTOMATIC VALVE CLOSURE	PROPOSED METHOD: SECONDARY CONTAINMENT	PROPOSED METHOD FOR INFREQUENTLY FILLED TANKS: MANUAL VALVE CLOSURE
<p>AVAILABILITY: Whether technology is best in use in other similar situations or is available for use by applicant</p>	<p>Technology is available and it is commonly done in piping systems.</p>	<p>Technology is available and is commonly used. Interstitial space of double-wall tank construction and toed platform will provide secondary containment.</p>	<p>The oil transfer line for filling tank is manually operated with a check valve to prevent reverse flow.</p>
<p>TRANSFERABILITY: Whether each technology is transferable to applicant's operations</p>	<p>Transferable.</p>	<p>Transferable.</p>	<p>Transferable.</p>
<p>EFFECTIVENESS: Whether there is a reasonable expectation each technology will provide increased spill prevention or other environmental benefits</p>	<p>Additional automation would afford little benefit given the existing filling procedures and requirement for continuous on-site presence of operator during fill operation.</p>	<p>This technology has proven highly effective in minimizing the spread of spilled oil from a tank leak.</p>	<p>Because operators are required to remain at or near the tank during fill operation and an audible alarm is provided should the tank reach a high level, manual intervention is effective in source control.</p>
<p>COST: The cost to the applicant of achieving BAT, including consideration of that cost relative to the remaining years of service of the technology in use by the applicant</p>	<p>Automation of this valve would cost \$15,000 to \$20,000 over the base case. ExxonMobil still requires the operator be at the fill site to oversee the fill operation.</p>	<p>This is the base case option.</p>	<p>This is the base case option.</p>
<p>AGE AND CONDITION: The age and condition of technology in use by the applicant</p>	<p>Method is more complex and current.</p>	<p>The system is simple, well proven and current.</p>	<p>The system is simple, well proven and current.</p>
<p>COMPATIBILITY: Whether each technology is compatible with existing operations and technologies in use by the applicant</p>	<p>Method is compatible.</p>	<p>Method is compatible.</p>	<p>Method is compatible.</p>
<p>FEASIBILITY: The practical feasibility of each technology in terms of engineering and other operational aspects</p>	<p>Method is feasible.</p>	<p>Method is feasible.</p>	<p>Method is feasible.</p>
<p>ENVIRONMENTAL IMPACTS: Whether other environmental impacts of each technology, such as air, land, water pollution, and energy requirements, offset any anticipated environmental benefits</p>	<p>There are no offsetting environmental impacts.</p>	<p>There are no offsetting environmental impacts.</p>	<p>There are no offsetting environmental impacts.</p>

NOTE: Tank fill valves close automatically on high level detection.

4.3 TRAJECTORY ANALYSES [18 AAC 75.425(e)(4)(A)(i)]

The BAT analysis for trajectory analyses and forecasts are described in the ACS *Technical Manual, Volume 1*.

ACS Tactic
L-11B

4.4 WILDLIFE CAPTURE, TREATMENT, AND RELEASE PROGRAMS [18 AAC 75.425(e)(4)(A)(i)]

The BAT analysis for wildlife capture, treatment, and release programs are described in the ACS *Technical Manual, Volume 1*.

ACS Tactic
L-11C

4.5 CATHODIC PROTECTION [18 AAC 75.425(e)(4)(A)(ii)]

Point Thomson oil storage tanks will be on elevated platforms and will not require cathodic protection. Regulation 18 AAC 75.445(k)(2) states that technology demonstrated to be in compliance with the performance standards in 18 AAC 75.005 through 18 AAC 75.080 are determined to be equivalent to BAT. The requirement for a BAT analysis is provided in 18 AAC 75.425(e)(4)(A)(ii) for cathodic protection or other approved corrosion protection control system if the system is required by 18 AAC 75.065(h)(3). However, that regulation requires corrosion control systems only for tank bottoms where soil conditions warrant. The Point Thomson tanks will not be in contact with soil, and consequently will not be subject to corrosion control system requirements. As such, no BAT analysis for a tank cathodic protection systems is necessary.

4.6 LEAK DETECTION SYSTEMS FOR TANKS [18 AAC 75.425(e)(4)(ii)]

The leak detection for the diesel tanks will be a sump on the tank double wall with an alarm level transmitter. In the event of a leak in the inner tank wall of the tank, diesel will flow through a 1-inch ball valve and sight flow glass, and into a 6-inch pipe. This pipe will act as a sump to collect leaked liquids. A level transmitter on the sump will trigger an alarm in the control room. A manual valved connection to the sump will provide for cleanout. The system has been selected due to its higher degree of sensitivity to leaks. The tank leak detection BAT review is provided in Table 4-5.

4.7 LEAK DETECTION FOR CRUDE OIL TRANSMISSION PIPELINES [18 AAC 75.425(e)(4)(A)(iv)]

The BAT analysis for the condensate export pipeline leak detection system addresses the following alternative technologies:

- Mass-Balance Line Pack Compensation (MBLPC)
- Visual surveillance
- Statistical Analysis of Pipeline Operating Conditions (SAPOC)
- Mass Balance (MB)
- Real-Time Transient Model (RTTM)

The rationale in determining the most appropriate leak detection system or systems for the Point Thomson condensate export pipeline will be based on operational philosophy, in addition to criteria stipulated in the BAT analysis. First, there must be redundancy (i.e., reliance not placed on a single leak detection system). Secondly, the technology should be state-of-the-art and capable of immediately detecting a sudden large-volume loss of product

**TABLE 4-5
BEST AVAILABLE TECHNOLOGY ANALYSIS
TANK LEAK DETECTION**

BAT EVALUATION CRITERIA	PROPOSED METHOD: EXTERNAL SUMP WITH ALARM LEVEL SWITCH	PROPOSED METHOD: FLOAT OPERATED EXTERNAL CAGE LEVEL SWITCH	ALTERNATE METHOD: ANNULAR SPACE DETECTION
AVAILABILITY: Whether technology is best in use in other similar situations or is available for use by applicant	A collection basin or sump is standard practice in the oil and most other industries.	Method is available and used by double-wall tank manufacturers.	This method could be used as an alternate or a backup to the sump level switch system.
TRANSFERABILITY: Whether each technology is transferable to applicant's operations	Method is transferable.	Method is transferable.	Method is transferable.
EFFECTIVENESS: Whether there is a reasonable expectation each technology will provide increased spill prevention or other environmental benefits	This method provides a means of rapidly identifying any leak and sounding an alarm to Operations.	This method provides a means of rapidly identifying any leak and annunciating an alarm to Operations.	This method would provide adequate leak detection, however, a larger spill would have to occur before it could be detected and annunciating to Operations.
COST: The cost to the applicant of achieving BAT, including consideration of that cost relative to the remaining years of service of the technology in use by the applicant	Cost is minimal.	Cost is minimal.	Cost is minimal.
AGE AND CONDITION: The age and condition of the technology in use by the applicant	Method is proven technology that has been used for many years.	Method is proven technology.	Method is proven technology used by double-wall tank manufacturers.
COMPATIBILITY: Whether each technology is compatible with existing operations and technology in use by the applicant	Method is compatible.	Method is compatible.	Method is compatible.
FEASIBILITY: The practical feasibility of each technology in terms of engineering and other operational aspects	Detects a leak based on a rising level.	Detects a leak based on a rising level.	Detects a leak based on a rising level.
ENVIRONMENTAL IMPACTS: Whether other environmental impacts of each technology, such as air, land, water pollution and energy requirements, offset any anticipated environmental benefits	Standard practice, simple, few moving parts, no maintenance.	Standard practice, simple, no maintenance.	Simple, no moving parts, no maintenance.

as well as detecting a low threshold chronic (pinhole) leak. Thirdly, the system should be commercially available, in use on similar pipeline systems, and available from a vendor with a proven track record. See Table 4-6 for BAT analysis of leak detection for the export pipeline.

Each leak detection system has strengths and weaknesses that depend on the specific pipeline operating characteristics. The type of system selected depends on the combination of several technologies, including flow measurement, instrumentation, communications, and computer hardware and software. Additional considerations include experience operating a system under similar circumstances (e.g., similar pipeline flow conditions) and compatibility with existing systems in the same pipeline network.

Although a specific vendor of the leak detection system has not been selected, our current analysis of the leak detection technology indicates that capabilities equivalent to those previously identified as BAT for similar pipelines can be achieved for the Point Thomson condensate export pipeline.

Mass Balance Line Pack Compensation

The MBLPC system provides a very accurate method of detecting smaller leaks over a longer period of time or larger leaks over a short period of time. Operational experience at other North Slope oil fields using the MBLPC system has verified that it provides the most reliable and accurate method of pipeline leak detection.

The MBLPC system works by continuously measuring the amount of condensate entering and leaving the pipeline. The system relies on accumulating the differences between the inflow and outflow meters. The higher the meter accuracy, the faster and more sensitively the MBLPC system can perform. Pipeline flow data are presented to the leak detection computer in timed data sets that are aggregated over longer time segments referred to as accumulators. Pressure is also accurately measured using pressure transmitters. The computer calculates the corrected volume of oil entering and leaving the pipeline system. Typically, discrepancies are calculated between these values and compared on a time-segment (accumulator) basis. Based on past operating experience, a leak detection threshold of 1 percent of daily throughput can be expected for the MBLPC system.

Visual Surveillance

Visual surveillance provides a supplement to on-line leak detection systems and has been used on the North Slope as well as other areas of the United States. Visual surveillance can validate alarms generated by the on-line system, as well as aid in the detection of small leaks that may be below the threshold limit of the system. It is simple to implement as part of general daily operations and does not involve up-front costs.

Statistical Analysis of Pipeline Operating Conditions

The SAPOC uses pressure transducers located at the CPF and Badami pipeline tie-in. Pressure readings are recorded, stored, and analyzed within the leak detection system software. When pressure records are identified by the software to be outside an acceptable range, the leak detection system generates an alarm. The level of analysis, the number of stored variables, and the modeling algorithm provide for some capability of leak detection in flow with pressure transients. Additionally, SAPOC has the capability of locating a leak through analysis of the pressure data.

**TABLE 4-6
BEST AVAILABLE TECHNOLOGY ANALYSIS
LEAK DETECTION FOR CONDENSATE EXPORT PIPELINE**

BAT EVALUATION CRITERIA	PROPOSED METHOD: MASS BALANCE LINE PACK COMPENSATION (MBLPC)	PROPOSED METHOD: VISUAL SURVEILLANCE	PROPOSED METHOD: STATISTICAL ANALYSIS OF PIPELINE OPERATING CONDITIONS (SAPOC)	ALTERNATE SYSTEM: MASS BALANCE (MB)	ALTERNATE SYSTEM: REAL TIME TRANSIENT MODEL (RTTM)
AVAILABILITY: Whether technology is best in use in other similar situations or is available for use by applicant	MBLPC is widely used on condensate pipelines and is commercially available.	Technology is available.	SAPOC is widely used on condensate pipelines and is commercially available.	MB has been widely used on condensate pipelines. It performs best under steady-state conditions. However, vendors are now recommending MBLPC over MB because MBLPC offers better performance than MB.	RTTM is used in condensate pipelines. However it is best suited for transient flow conditions.
TRANSFERABILITY: Whether each technology is transferable to applicant's operations	MBLPC is used on condensate pipelines. It performs best if: 1. Transient flow conditions do not occur frequently. 2. There is no multi-phase flow. 3. There is no slack-line flow.	Can be used.	SAPOC technology is used on condensate pipelines. It performs when: 1. Transient flow conditions do not occur frequently. 2. There is no multi-phase flow. 3. There is no slack-line flow.	MB technology is widely used on condensate pipelines. It performs best if: 1. The condensate pipeline operates in a steady-state mode. 2. There is no batching. 3. There is no multi-phase flow. 4. There is no slack-line flow. 5. Temperature remains constant. 6. Pipeline is relatively short (on the order of 20 miles long).	RTTM is applicable to condensate pipelines. However, it is more appropriate for multi-phase flow conditions, transient flow conditions, and pipeline networks.
EFFECTIVENESS: Whether there is a reasonable expectation each technology will provide increased spill prevention or other environmental benefits	Can detect leaks that are as low as 1 percent of daily condensate throughput. MBLPC system performance is dependent upon the accuracy of condensate pipeline flow meters.	An effective means of identifying a leak that can be visually detected. Sometimes leaks occur that are below the threshold limit of the leak detection system and are spotted by visual detection. Must be used in conjunction with an automated leak detection system.	Can detect leaks that are as low as 1 percent of daily throughput. The system's performance is somewhat dependent on upon pump or compressor performance.	This method is less effective than MBLPC.	Can detect leaks that are 1 percent of the daily throughput even when the flow is transient.
COST: The cost to the applicant of achieving BAT, including consideration of that cost relative to the remaining years of service of the technology is use by the applicant.	Less than \$350,000.	The cost is based on the number of trips to cover the pipeline right-of-way. No up-front investment.	Less than \$350,000.	Approximate cost is \$50,000. It is the least expensive system to install.	Approximate cost is \$350,000. RTTM is the most expensive system to implement and maintain.
AGE AND CONDITION: The age and condition of technology in use by the applicant	The required software and hardware will be new when installed.	Method is current.	The required software and hardware will be new when installed.	The required software and hardware would be new when installed.	The required software and hardware will be new when installed.

**TABLE 4-6 (CONTINUED)
BEST AVAILABLE TECHNOLOGY ANALYSIS
LEAK DETECTION FOR CONDENSATE EXPORT PIPELINE**

BAT EVALUATION CRITERIA	PROPOSED METHOD: MASS BALANCE LINE PACK COMPENSATION (MBLPC)	PROPOSED METHOD: VISUAL SURVEILLANCE	PROPOSED METHOD: STATISTICAL ANALYSIS OF PIPELINE OPERATING CONDITIONS (SAPOC)	ALTERNATE SYSTEM: MASS BALANCE (MB)	ALTERNATE SYSTEM: REAL TIME TRANSIENT MODEL (RTTM)
<p>COMPATIBILITY: Whether each technology is compatible with existing operations and technologies in use by the applicant</p>	<p>MBLPC is compatible with SCADA and is combined with Statistical Analysis of Pipeline Operating Conditions.</p>	<p>Method is compatible with all leak detection systems.</p>	<p>SAPOC is compatible with SCADA.</p>	<p>MB is compatible with SCADA.</p>	<p>RTTM is compatible with SCADA.</p>
<p>FEASIBILITY: The practical feasibility of each technology in terms of engineering and other operational aspects</p>	<p>MBLPC is routinely used on relatively short pipelines (on the order of 20 miles long).</p>	<p>Method is not feasible to continuously monitor the entire pipeline. Is useful as supplement to an on-line leak detection system.</p>	<p>SAPOC is a state-of-the-art proven technology.</p>	<p>MB is simple to implement on relatively short (approximately 20 miles) pipelines.</p>	<p>RTTM is a relatively complex and costly system to implement on condensate pipelines. It requires system calibration to tune detection accuracy and additional data measurements to calculate system response. Operators need higher level training to provide reliable operation.</p>
<p>ENVIRONMENTAL IMPACTS: Whether other environmental impacts of each technology, such as air, land, water pollution, and energy requirements, offset any anticipated environmental benefits</p>	<p>None, the system is preventive in nature. Implementation will significantly reduce oil loss to the environment if a leak were ever to occur.</p>	<p>None.</p>	<p>This system provides the assurance of reliable leak detection. Implementation will significantly reduce condensate loss to the environment if a leak were ever to occur.</p>	<p>MB is an effective leak detection system. Implementation will significantly reduce oil loss to the environment if a leak were ever to occur.</p>	<p>None, the system is preventive in nature. Implementation will significantly reduce oil loss to the environment if a leak were to occur.</p>

Real Time Transient Modeling

The most sensitive, but also the most complex and costly leak detection method in use is RTTM. RTTM involves the computer simulation of pipeline conditions using advanced fluid mechanics and hydraulic modeling. Conservation of momentum calculations, conservation of energy calculations, and numerous flow equations are typically used by the RTTM system. RTTM software can predict the size and location of leaks by comparing the measured data for a segment of pipeline with the predicted modeled conditions. This analysis is done in a three-step process. First, the pressure-flow profile of the pipeline is calculated based on measurements at the pipeline or segment inlet. Second, the pressure-flow profile is calculated based on measurements at the outlet. Third, the two profiles are overlapped and the location of the leak is identified as the point where these two profiles intersect. If the measured characteristics deviate from the computer prediction, the RTTM system sends an alarm to the pipeline controller. The more instruments that are accurately transmitting data into the model, the higher the accuracy of, and confidence in the model. Note that models rely on properly operating and calibrated instruments for optimum performance. Calibration errors can result in false alarms or missed leaks, and the loss of a critical instrument could require system shutdown.

The advantage RTTM provides over other methods is its ability to model all of the dynamic fluid characteristics (flow, pressure, temperature) and take into account the extensive configuration of physical pipeline characteristics (length, diameter, thickness, etc.), as well as product characteristics (density, viscosity, etc.). Additionally, the model can be tuned to distinguish between instrument errors, normal transients, and leaks. The distinct disadvantages of this system are the costs associated with implementing RTTM and the complexity of the system, which requires numerous instruments and extensive controller training and system maintenance.

Conclusion

The conclusion arising from the BAT review is that a combination of the MBLPC and visual surveillance systems is most appropriate for the Point Thomson condensate pipeline. The SAPOC will serve as a redundant system to the MBLPC and visual surveillance systems. The combination of these leak detection systems provides the ability to rapidly detect large and small volume leaks.

4.8 LIQUID LEVEL DETERMINATION [18 AAC 75.425(e)(4)(A)(ii)]

The liquid level transmitters for the ADEC-regulated tanks use state-of-the-art technology. Redundant electronic level transmitters mounted on the tank sense liquid level through a radar-type level transmitter. The transmitters sense a liquid level by measuring the distance from the top of the tank to the vapor/liquid interface. One transmitter signals the PCS, which controls tank level while displaying and alarming level readings in the control room. The secondary level gauge is for safety and signals the safety system. The safety system provides a backup level indication, alarms, and shutdown of equipment, and isolates the unit. Isolation valves are electrically and pneumatically opened and spring-closed, thereby ensuring positive action and isolation upon failure of either pneumatic or electrical power, even under extreme low-temperature conditions (Table 4-7A).

The controller for the storage and dispensing control system is modern state-of-the-art PCS. A safety instrumented system (SIS) ensures total reliability. The SIS has its own dedicated level gauge and shutdown valve and operates independently from the PCS. The SIS takes

THIS PAGE INTENTIONALLY LEFT BLANK

**TABLE 4-7A
BEST AVAILABLE TECHNOLOGY
STATIONARY STORAGE TANK LIQUID LEVEL DETERMINATION**

BAT EVALUATION CRITERIA	PROPOSED METHOD: RADAR CONTINUOUS LEVEL	PROPOSED METHOD: MICROPROCESSOR-BASED ELECTRONIC CONTROL SYSTEM	ALTERNATE METHOD: ULTRASONIC LEVEL SWITCH, CAPACITANCE LEVEL SWITCH, OR FLOAT LEVEL SWITCH WITH HARD-WIRED RELAY LOGIC CONTROL SYSTEM	ALTERNATE METHOD: PNEUMATIC CONTROL SYSTEM
<p>AVAILABILITY: Whether technology is best in use in other similar situations or is available for use by applicant</p>	<p>Radar technology is used in similar applications. It is being used on tanks for level determination. It is non-contact and not pressure, temperature or density dependent.</p>	<p>Microprocessor-based controllers are used in almost all electronic control systems in industry today. The reason for the popularity of controllers is that the controllers have proven to be BAT over the past 20+ years.</p>	<p>Hardware relay logic control systems are still in use today, but are becoming less popular. Ultrasonic point level switches are used in tanks throughout the world. Capacitance level switches are used in tanks throughout the world. Float level switches have been used throughout the world but are not as popular as they used to be since the use of ultrasonic and capacitance level switches.</p>	<p>Pneumatic control systems are used in very few applications today and never where pumps and motors are turned on or off.</p>
<p>TRANSFERABILITY: Whether each technology is transferable to applicant's operations</p>	<p>Transferable to applicant operations. Tanks would be outfitted with a nozzle so instrumentation can be installed.</p>	<p>Emerson Delta V and all instrumentation are completely transferable to applicant's operations. Many facilities on the North Slope of Alaska use Allen Bradley PLCs or equivalent. The central plant control system will use Emerson Delta V for control and a TÜV (Technische Überwachungs Verein [a network of German certification agencies]) approved safety PLC for backup protection. The brands and models of instrumentation used in the control system design are also common to the central facility. Both Delta V or the backup safety PLC are equal to or better than an Allen Bradley PLCs. In combination, they give much greater control and reliability than a single Allen Bradley PLC.</p>	<p>Ultrasonic level switch is transferable to the Emerson Process Management Delta V process control system (PCS) and a TÜV approved safety PLC (e.g. ICS Triplex, Triconex, or HIMA triple redundant or redundant one out of two voting system). Capacitance level switch is transferable to Delta V for control with a TÜV approved PLC as a safety backup. Float level switch is transferable to the Allen Bradley PLC.</p>	<p>Transferable.</p>

**TABLE 4-7A (CONTINUED)
BEST AVAILABLE TECHNOLOGY ANALYSIS
STATIONARY STORAGE TANK LIQUID LEVEL DETERMINATION**

BAT EVALUATION CRITERIA	PROPOSED METHOD: RADAR CONTINUOUS LEVEL	PROPOSED METHOD: MICROPROCESSOR-BASED ELECTRONIC CONTROL SYSTEM	ALTERNATE METHOD: ULTRASONIC LEVEL SWITCH, CAPACITANCE LEVEL SWITCH, OR FLOAT LEVEL SWITCH WITH HARD-WIRED RELAY LOGIC CONTROL SYSTEM	ALTERNATE METHOD: PNEUMATIC CONTROL SYSTEM
<p>EFFECTIVENESS: Whether there is a reasonable expectation each technology will provide increased spill prevention or other environmental benefits</p>	<p>Continuous level is non-contact and not pressure, temperature or density dependent. Can be affected by mist, steam, foam or turbulence.</p>	<p>Critical operation parameters such as tank levels are continuously monitored by both the control system and the safety system PLC and are displayed for easy operator reference. Any abnormal condition (i.e., high tank level) activates automatic safeguards (i.e., close tank inlet valves) to prevent spills, etc. Pre-alarms alert operators of pending abnormal conditions. The entire control system is designed to be fail safe. All field sensing devices, PLC hardware and software, and field-actuating devices are designed to stop diesel/methanol flow in the event any device fails. Dispensing pump incorporates an emergency shutdown valve (ESV) that closes under impact or fire exposure.</p>	<p>Relay systems do not provide for logic status monitoring or alarming. This method provides an easy means of identifying exactly when the level switch will activate. Repeatability is within 1/16 inch and this method has no moving parts. Capacitance level switch method would be a reliable means of detecting a high level, however it requires a minimum of 2 inches of probe above and below the liquid level. Also, if the dielectric of liquid changes, the point of switching would change. Float level switch method would provide adequate level sensing. However, float levels have been known to stick in certain applications.</p>	<p>Pneumatic systems are prone to freezing if moisture build-up occurs in the tubing.</p>
<p>COST: The cost to the applicant of achieving BAT, including consideration of that cost relative to the remaining years of service of the technology in use by the applicant</p>	<p>Could require an additional instrument connection on the vessel, as well as routing of power for the unit. The cost could be in excess of \$50,000.</p>	<p>All instruments and control system hardware were purchased to be fit for purpose, technically acceptable, and reasonably priced based on budgetary pricing. All instrument and controls technology used in the system design should remain in service for at least the next 20 years. Design changes can be implemented at minimal costs.</p>	<p>Cost is minimal.</p>	<p>The cost of design changes to a pneumatic logic system is high. Re-tubing is required for revision.</p>
<p>AGE AND CONDITION: The age and condition of the technology in use by the applicant</p>	<p>The required software and hardware would be new when installed.</p>	<p>All instrument and controls equipment is brand new, purchased specifically for this project.</p>	<p>The required software and hardware would be new when installed. Float level switch is an older technology.</p>	<p>The required software and hardware would be new when installed.</p>

**TABLE 4-7A (CONTINUED)
BEST AVAILABLE TECHNOLOGY ANALYSIS
STATIONARY STORAGE TANK LIQUID LEVEL DETERMINATION**

BAT EVALUATION CRITERIA	PROPOSED METHOD: RADAR CONTINUOUS LEVEL	PROPOSED METHOD: MICROPROCESSOR-BASED ELECTRONIC CONTROL SYSTEM	ALTERNATE METHOD: ULTRASONIC LEVEL SWITCH, CAPACITANCE LEVEL SWITCH, OR FLOAT LEVEL SWITCH WITH HARD-WIRED RELAY LOGIC CONTROL SYSTEM	ALTERNATE METHOD: PNEUMATIC CONTROL SYSTEM
COMPATIBILITY: Whether each technology is compatible with existing operations and technology in use by the applicant	This technology is compatible with existing operations and technologies.	Allen Bradley PLCs are used at various facilities on the North Slope of Alaska. The central control system will use both Delta V or the backup safety PLC are equal to or better than an Allen Bradley PLCs. In combination, they give much greater control and reliability than a single Allen Bradley PLC.	Method is compatible.	Method is compatible.
FEASIBILITY: The practical feasibility of each technology in terms of engineering and other operational aspects	Would require modifications to the vessel that would incur additional cost without any substantial increase in availability/reliability.	Allen Bradley PLCs or equivalent are easily programmed, commissioned, and maintained because of their software-based systems. All programming is compliant with International Electrotechnical Commission (IEC) 1131-3. System status, input/output status, and program status alarms are readily available to operating and maintenance personnel for troubleshooting. All PLC information is available for displaying on computers for quick and accurate operating responses to abnormal conditions.	Engineering revisions to relay logic systems are very time-consuming and costly. Maintenance is very low-tech and often causes more spurious trips than it prevents. Operator interface is available locally only.	Engineering revisions to pneumatic control systems are very time-consuming and costly. Operator interface is available locally only.
ENVIRONMENTAL IMPACTS: Whether other environmental impacts of each technology, such as air, land, water pollution and energy requirements, offset any anticipated environmental benefits	No additional environmental impacts; unit requires external power.	Electrically and electro-pneumatically operated valves provide high reliability for shutting down the diesel flow while consuming minimal amounts of energy.	None.	None.

corrective action (e.g. shuts down the tank) should the PCS and/or the operators fail to adequately control tank level. The control and safety system have the following design features:

- They are the state-of-the-art systems used in logic control and alarming.
- They have replaced relay systems because of the ease of programming in software versus hardware and interconnected wiring. Components are standardized and are easily replaced using off-the-shelf items.
- Both the PCS and the SIS have on-line continuous diagnostics capable of detecting and reporting equipment faults and failures on a real-time basis. Both have built in redundancy of controller, I/O cards, and power supplies.
- Both the PCS and SIS hardware and software can be selected, configured, and programmed to be fail-safe by detecting hardware and software failures and taking the appropriate control or alarm action.
- The data resident in PCS and SIS controllers can be easily accessed by computers or information technology departments using standardized databases.

Both the PCS and SIS programming databases are password protected. Only authorized personnel have access to make logic or shutdown sequence changes.

Table 4-7B presents BAT analysis for liquid level determination on portable storage tanks. On portable and temporary tanks the electronic types of liquid level indicators, which typically employ ultrasonic or microwave frequency transducers, are not BAT. Small portable tanks that are mounted on motor vehicles are subject to vibrations and jolts from being transported on unimproved roads and from wind gusts. These conditions result in liquid level measurements that fluctuate constantly, particularly for the more sensitive devices such as microwave frequency.

Float-type devices are particularly prone to jamming under these conditions. While it is possible to tune associated controller outputs to mitigate the effects of vibration and jolts, such a state of tune would significantly decrease their accuracy and response times in terms of liquid level measurement and preclude their use as leak detection devices.

Small temporary tanks on gravel pads or rigs are subject to similar vibrations and jolts. Accordingly, the use of sensitive liquid level devices on small portable and temporary tanks results in liquid level measurement errors and frequent false alarms. Handling during loading, transportation, and unloading may also result in physical damage to the level determination device or electronic components.

In addition, should the liquid level indicating devices be used to control automatic shutoff valves or pump shutoff relays, unanticipated valve closures or pump shutdowns may occur, potentially resulting in a release of product. The inability of the devices to function accurately and reliably on small portable and temporary tanks, and the significant cost of custom construction, installation, and maintenance preclude their use.

Flow-test tank fluids are typically composed of oil, water, associated emulsions and suspended solids. The multiphase nature of these fluids adversely impacts the accuracy and reliability of a variety of level determination devices. For example, the accuracy of microwave frequency devices is compromised by variations in liquid dielectric constant and electrical conductivity. As a result, application in multiphase liquid contexts is contraindicated.

**TABLE 4-7B
BEST AVAILABLE TECHNOLOGY ANALYSIS
PORTABLE STORAGE TANK LIQUID LEVEL DETERMINATION SYSTEM**

BAT EVALUATION CRITERIA	PROPOSED METHOD: VISUAL OBSERVATION	ALTERNATE METHOD: MICROPROCESSOR-BASED ELECTRONIC CONTROL SYSTEM	ALTERNATE METHOD: HARD-WIRED RELAY LOGIC CONTROL SYSTEM	ALTERNATE METHOD: PNEUMATIC CONTROL SYSTEM
AVAILABILITY: Whether technology is best in use in other similar situations or is available for use by applicant	Existing method.	Microprocessor-based programmable logic controllers (PLCs) are used in almost all electronic control systems in industry today. The reason for PLCs' popularity is that the controllers have proven to be BAT over the past 20+ years.	Hardwired relay logic control systems are still in use today but are becoming less popular.	Pneumatic control systems are used in very few applications today and never where pumps and motors are turned on or off.
TRANSFERABILITY: Whether each technology is transferable to applicant's operations	Transferable.	Allen Bradley SLC5 PLCs and all instrumentation are not transferable to the drill rigs.	Transferable, but not practical.	Undetermined.
EFFECTIVENESS: Whether there is a reasonable expectation each technology will provide increased spill prevention or other environmental benefits	Highly effective with strict adherence to BMP and local procedure. Tank liquid levels will be determined from direct observation through the hatch using a flashlight, fuel strapping tape, etc.	Not effective in this application.	Not effective in this application. In addition, relay systems do not provide for logic status monitoring or alarming.	Not effective in this application. In addition, pneumatic systems are prone to freezing if moisture build-up occurs in the tubing.
COST: The cost to the applicant of achieving BAT, including consideration of that cost relative to the remaining years of service of the technology in use by the applicant.	Not applicable.	The cost to redesign the rig and its associated storage tank would be high.	The cost of design changes to a relay based logic system is high. Re-wiring is required for any revision.	The cost of design changes to a pneumatic logic system is high. Re-tubing is required for any revision.
AGE AND CONDITION: The age and condition of technology in use by the applicant	Procedures have been in place since 1993 for fuel transfer operations.	Current technology.	Current technology.	Current technology.
COMPATIBILITY: Whether each technology is compatible with existing operations and technologies in use by the applicant	Compatible and widely used. Requires no change.	Compatible but not used on portable tanks and tanks on rigs.	Compatible but not used on portable tanks and tanks on rigs.	Compatible but not used on portable tanks and tanks on rigs.
FEASIBILITY: The practical feasibility of each technology in terms of engineering and other operational aspects	Feasible and preferred due to potential for electronic or pneumatic systems to experience damage from rough handling.	Rig tanks are frequently moved over rough roads. Rough handling has the potential to affect the accuracy and/or operability of the system.	Rig tanks are frequently moved over rough roads. Rough handling has the potential to affect the accuracy and/or operability of the system.	Rig tanks are frequently moved over rough roads. Rough handling has the potential to affect the accuracy and/or operability of the system.
ENVIRONMENTAL IMPACTS: Whether other environmental impacts of each technology, such as air, land, water pollution, and energy requirements offset any anticipated environmental benefits	None.	None.	None.	None.

Alternatively, ultrasonic devices require contact with the process fluid; solids build-up or emulsion adherence to the sensor results in decreased accuracy and the need for frequent maintenance. Float-type devices are also subject to greatly reduced accuracy and reliability resulting from the solids content. The solids may cause float sticking and jamming. In addition, extreme cold weather results in pulleys that may not roll freely or may freeze up altogether, or associated cable systems that become inflexible. Any one or more of these effects renders the device unreliable.

Manufacturers of electronic devices indicate that temperatures lower than -30°F compromise the reliability and response time of the electronic components of these devices. Comprehensive review of historical weather data for the subject North Slope locations indicate that extreme low temperatures range from -58°F to -85°F. Use of these devices in such extreme low temperatures is not recommended.

In summary, the application of liquid level determination devices (in addition to manual gauging and direct observation) to portable and temporary tanks in remote arctic environments is not desirable for the following reasons:

- Significant potential for physical damage or damage to associated electronic components as a result of loading, unloading, or transportation.
- Requirement for power source, i.e., a potential source of ignition.
- Need for frequent maintenance.
- Lack of warranty.
- Decreased accuracy.
- Decreased reliability.
- Significant cost (e.g., device, power, installation, maintenance, and replacement).

As a consequence of these considerations, ExxonMobil proposes to use current BMP (Appendix A) for transfer procedures and visual inspection as BAT for liquid level determination in portable and temporary tanks.

Visual tank-liquid-level inspection consists of:

- Two personnel present during transfer, maintaining constant line-of-sight and communication;
- One person pumps while the other person constantly monitors tank levels throughout transfer; and
- Positive means of shutting off transfer.

4.9 PROTECTIVE WRAPPING OR COATINGS FOR TANKS AND PIPELINES [18 AAC 75.425(e)(4)(A)(ii)]

4.9.1 Tank Corrosion Protective Coating

A BAT analysis has not been performed for tank protective wrappings and coatings since the storage tanks at Point Thomson will be above-grade and therefore will not require protective wrappings or coatings.

4.9.2 Pipeline Corrosion Protective Coating

The Point Thomson condensate export pipeline and the gathering lines will be maintained aboveground for their entire lengths, except at road crossings. At road crossings the pipelines will pass through larger diameter pipes (sometimes called casings) and will be electrically isolated from the casing and the road materials. The pipeline inside the casing will be maintained with spacers for stability.

As required by 18 AAC 75.080(b)(1)(A), below-grade pipelines are protected from external corrosion by an external coating (Table 4-8). The available technologies for this coating are:

- Dual-layer fusion-bonded epoxy (FBE) for corrosion and mechanical protection,
- Single layer of conventional FBE for corrosion protection,
- Paint, and
- Coal tar enamel.

Of the four technologies, dual-layer FBE is considered the best available technology based on the physical properties of each technology in relation to the physical environment of the Point Thomson pipelines (Table 4-8).

Both dual-layer and single-layer FBE coatings are ductile. Dual-layer FBE, composed of an inner layer of conventional FBE for corrosion protection and an outer layer of impact-resistant FBE for mechanical protection, are more durable than a single-layer FBE coating. The inner layer of the dual-layer FBE coatings is the conventional FBE material that has been effective as a corrosion protection coating. Both layers, which are feasible to apply, have a low coating-breakdown factor causing less impact to the environment while making the dual-layer FBE coating compatible with sacrificial anodes. High coating-breakdown factors adversely affect sacrificial anode systems. The cost to apply the dual-layer FBE coating in a new condition is considered reasonable.

The Point Thomson condensate export pipeline will be carbon steel and will be coated with FBE at road crossings. The gathering lines will be constructed of Duplex stainless steel and will not be externally coated for corrosion protection. They will be covered with a coating of polyurethane foam for insulation purposes for their entire lengths.

4.10 CATHODIC PROTECTION FOR TANKS AND PIPELINES [18 AAC 75.425(e)(4)(A)(ii)]

4.10.1 Tanks

A BAT analysis has not been performed for tank cathodic protection since the storage tanks at Point Thomson will be above-grade and therefore will not require cathodic protection.

4.10.2 Pipelines

A BAT analysis has not been performed for pipeline cathodic protection since below-grade pipelines will be FBE-coated and cased, and will not be in direct contact with soil. Therefore, pipelines will not require cathodic protection.

**TABLE 4-8
BEST AVAILABLE TECHNOLOGY ANALYSIS
EXTERNAL COATINGS FOR BELOW GRADE SECTIONS OF PIPELINE**

BAT EVALUATION CRITERIA	PROPOSED METHOD: FUSION BONDED EPOXY	ALTERNATE METHOD: COAL TAR OR EXTRUDED POLYETHYLENES	ALTERNATE METHOD: PAINTS (ENAMEL OR ZINC OXIDE PRIMER)	ALTERNATE METHOD: NO COATING
AVAILABILITY: Whether technology is best in use in other similar situations or is available for use by applicant	Technology is available and is used.	Technology is available and is used. Not available in existing coating mills in Alaska.	Technology is available and is used for aboveground piping.	Technology is available.
TRANSFERABILITY: Whether each technology is transferable to applicant's operations	Can be used.	Can be used.	Can be used.	Can be used.
EFFECTIVENESS: Whether there is a reasonable expectation each technology will provide increased spill prevention or other environmental benefits	Effective means to provide coverage.	Would likely not be as effective as FBE. Likely to be damaged in shipment to the site at low temperatures and is not reliable within the pipeline operating temperatures.	Does not provide the protection that is required for below-grade pipe that comes in contact with soils.	Not effective means of providing protection of the below-grade sections of the pipeline. Also DOT regulations require that new pipelines have external coating.
COST: The cost to the applicant of achieving BAT, including consideration of that cost relative to the remaining years of service of the technology in use by the applicant	Comparable to other coating alternatives.	Comparable to other coating alternatives.	Comparable to other coating alternatives.	There would be no cost.
AGE AND CONDITION: The age and condition of technology in use by the applicant	Method is current.	Method is current.	Method is current.	Method is current.
COMPATIBILITY: Whether each technology is compatible with existing operations and technologies in use by the applicant	Compatible with coating systems and installation method proposed.	Not compatible with cold temperature environment that the pipe will be installed in.	Not compatible with pipe that comes in contact with soils.	Compatible.
FEASIBILITY: The practical feasibility of each technology in terms of engineering and other operational aspects	Method is feasible and is commonly used.	Not feasible to use because it will not provide the level of protection required based on the operating temperature of the pipeline.	Not appropriate coating for a below-grade pipeline.	Not feasible to have uncoated below-grade pipe. DOT regulations require that new lines have external corrosion coating.
ENVIRONMENTAL IMPACTS: Whether other environmental impacts of each technology, such as air, land, water pollution, and energy requirements, offset any anticipated environmental benefits	No additional environmental impacts.	Coal tar coatings present possible environmental concerns when coating has to be removed for maintenance or field installation.	No additional environmental impacts.	No additional environmental impacts.

TABLE OF CONTENTS FOR SECTION 4

4. BEST AVAILABLE TECHNOLOGY [18 AAC 75.425(e)(4)] 4-1

4.1 COMMUNICATIONS [18 AAC 75.425(e)(4)(i)] 4-1

4.2 SOURCE CONTROL [18 AAC 75.425(e)(4)(A)(i)] 4-1

 4.2.1 Well Source Control 4-1

 4.2.2 Pipeline Source Control..... 4-6

 4.2.3 Tank Source Control 4-6

4.3 TRAJECTORY ANALYSES [18 AAC 75.425(e)(4)(A)(i)] 4-10

4.4 WILDLIFE CAPTURE, TREATMENT, AND RELEASE PROGRAMS [18 AAC 75.425(e)(4)(A)(i)] 4-10

4.5 CATHODIC PROTECTION [18 AAC 75.425(e)(4)(A)(ii)] 4-10

4.6 LEAK DETECTION SYSTEMS FOR TANKS [18 AAC 75.425(e)(4)(ii)] 4-10

4.7 LEAK DETECTION FOR CRUDE OIL TRANSMISSION PIPELINES [18 AAC 75.425(e)(4)(A)(iv)] 4-10

4.8 LIQUID LEVEL DETERMINATION [18 AAC 75.425(e)(4)(A)(ii)] 4-15

4.9 PROTECTIVE WRAPPING OR COATINGS FOR TANKS AND PIPELINES [18 AAC 75.425(e)(4)(A)(ii)] 4-22

 4.9.1 Tank Corrosion Protective Coating 4-22

 4.9.2 Pipeline Corrosion Protective Coating..... 4-23

4.10 CATHODIC PROTECTION FOR TANKS AND PIPELINES [18 AAC 75.425(e)(4)(A)(ii)] 4-23

 4.10.1 Tanks 4-23

 4.10.2 Pipelines 4-23

LIST OF TABLES

4-1 Best Available Technology Analysis Well Blowout Source Control 4-2

4-2 Best Available Technology Analysis Source Control On Condensate Export Pipeline .. 4-7

4-3 Best Available Technology Analysis Gathering And Well Oil Line Source Control 4-8

4-4 Best Available Technology Analysis Tank Source Control..... 4-9

4-5 Best Available Technology Analysis Tank Leak Detection..... 4-11

4-6 Best Available Technology Analysis Leak Detection For Condensate Export Pipeline 4-13

4-7A Best Available Technology Stationary Storage Tank Liquid Level Determination..... 4-17

4-7B Best Available Technology Analysis Portable Storage Tank Liquid Level Determination System 4-21

4-8 Best Available Technology Analysis External Coatings For Below Grade Sections Of Pipeline 4-24

APPENDIX A
BEST MANAGEMENT PRACTICES AND PROCEDURES

FLUID TRANSFER GUIDELINES

The following information on personnel safety and safe handling procedures for fluid transfer protocol follows the best management practices (BMP) of North Slope Operations as compiled from the *Alaska Safety Handbook* (2002). Information on the use of surface liners and drip pans is a jointly issued Unified Operating Procedure (UOP), summarized from the *North Slope Environmental Handbook* (May 2001).

OBJECTIVE

The objective of the Fluid Transfer Guidelines is to establish minimum requirements to protect the safety and health of employees when using vacuum and tanker trucks to transfer flammable and combustible fluids to or from non-permanent facilities. The objectives are to ensure that:

- Vacuum trucks shall never be directly hooked-up to pressurized lines or vessels. Tanks are not considered pressure vessels. Fluids discharged from pressurized sources are to be flowed into tanks rather than directly to the vacuum unit.
- Equipment used during transfer of flammable and combustible fluids meets applicable safety requirements.
- The layout of equipment adequately separates potential ignition sources from potential sources of flammable or combustible vapors or liquids, and provides for personnel egress.
- All personnel involved in transfer operations use appropriate precautions for handling flammable and combustible fluids.

EXCEPTIONS

Equipment fueling operations, permanent loading and unloading facilities (e.g., bulk fuel loading dock, oily waste, recycle facilities, and fixed chemical tanks), pumping fluid into a well, flowline, or other permanent facility, or routine use of a drill site or well pad bleed tank will continue according to established safe operating procedures.

RESPONSIBILITIES

Vehicle Contractor/Operator. Ensure proper training, safe operation, and maintenance of their equipment.

Company Representative. A Company Representative shall perform the following pre-job checkout before the start of any flammable or combustible fluid transfer to or from a non-permanent facility. If a particular situation cannot meet specifics of the following requirements, the Company Representative will take appropriate steps to safeguard personnel and equipment.

- Inspect the site of the loading and unloading operations. If a Contract Foreman will supervise the work, conduct the site visit with the Contract Foreman. Conduct a pre-job safety discussion and a job scope review, including the potential hazards of the work and emergency procedures, with all participants.
- Survey the truck and equipment to assure compliance with the policy criteria.
- Review loading positions, emergency escape routes, and fire lanes.
- Complete a pre-job safety meeting identifying potential hazards and escape routes. Identify a minimum of two emergency exit paths leading away from the transfer area for personnel

egress. At least two exit routes must be unobstructed with a minimum width of 5 feet and should be established perpendicular to the prevailing wind direction.

A Company Representative shall perform the following:

- Review the wind direction relative to the trucks and equipment layout. Monitor the prevailing wind conditions so any potential sources of hydrocarbons are kept at least 25 feet downwind of any potential ignition source.
- Locate the inlet and/or outlet piping (truck connections) and truck-mounted fluid pumping equipment 25 feet or more downwind from any potential ignition source on the site or on the back of the truck.
- Ensure the trucks and/or tank involved in the transfer are separated by at least 25 feet.
- Review positions of fire extinguishing equipment and ensure the operator is trained in its proper use.
- Maintain a minimum unobstructed pathway of 20 feet for fire and emergency vehicle access to the transfer area.
- Assure continuous electrical bonding between transfer equipment.
- Use the Unit Work Permit with the checklist on the back for all operations covered by this policy when a Company Representative is not present for the entire transfer.
- When venting at low ambient temperatures, there is potential for the vented gas to condense and possibly freeze off the vent and check valves. Ensure that when applicable, the operator monitors the condition and takes appropriate actions to mitigate the hazard.
- Test the means of communication for proper function.
- Ensure flammable and combustible fluids to be vacuumed are at least 40 degrees below their flash point.
- Liquid flash point measurement will be required for vacuumed operations as warranted by the Company Representative. Frequent tests are suggested, especially where the material may not be homogeneous.

A Company Representative shall ensure the North Slope Unified Operator Procedure on the use of drip pans/surface liners is followed for environmental protection, as described below.

NORTH SLOPE FLUID TRANSFER GUIDELINES

Note: SAFETY is the first and foremost goal in all operations, including the transfer of all fluids. It is EVERYONE'S responsibility to ensure all related safety and environmental guidelines are being followed at all times.

- 1) Check all vehicles and/or equipment. Ensure that it has been properly maintained and that there are no leaking parts. If your vehicle or equipment does not appear to be in proper order and leaks are apparent, stop the job and have adequate repairs done. In accordance with field operating procedures, a surface liner may be used for a short period of time under critical use equipment.
- 2) Stage vehicles away from water bodies, tundra and wildlife habitats. Staging or parking of vehicles and equipment in off-pad locations or on-pad edges should be avoided whenever possible.
- 3) Position equipment so that valves, piping, tanks, etc., are protected from damage by other vehicles or heavy equipment.
- 4) Verify that adequate secondary containment and absorbent pads are on hand. Use according to published field operating procedures.
- 5) Before starting any fluid transfer operation, inspect all hoses, connections, valves, etc. Ensure that these items have been properly maintained; gaskets are present and in good shape; all valves are checked to verify they're in the proper on/off position, and that each connection is tightened properly.
- 6) Prior to the actual fluid transfer, check all tank and container levels, valves, and vents to prevent overfilling or accidental releases.
- 7) Use secondary containment under all appropriate connections, vents or any other likely source of spillage. Use as many secondary containers as are practical, or as are required per the published field operating procedures.
- 8) Upon starting the transfer of liquids, keep line of sight with operator and/or all connections, hoses, vents or any other likely source of spillage. Be prepared to stop proceedings if any leak is noticed. Do not attempt to repair a leaking situation while fluid is being transferred. Stop operations to fix leaks.
- 9) Maintain a constant line-of-sight with critical components throughout the transfer. Transfer operations must not be left unattended.
- 10) After transfer is complete, take every precaution while breaking connections. Secondary containment and absorbent pads must continue to be used until the rigging down process is complete.
- 11) Check all tank and container levels after each transfer for signs of spills. Immediately report all spills to the Field Environmental group in your area.

APPENDIX B

POINT THOMSON REGULATED TANKS LISTS

**TABLE B-3
POINT THOMSON REGULATED (USEPA ONLY) STATIONARY CONTAINER DATA
TANKS LESS THAN 10,000 GALLONS**

TANK NO. TAG	DESCRIPTION	LOCATION	FABRICATION INSTALLATION DATE	CONSTRUCTION STANDARD	NOMINAL DESIGN CAPACITY	PRODUCT TYPE	SECONDARY CONTAINMENT VOLUME	SECONDARY CONTAINMENT DESCRIPTION	INFLOW CONTROL VALVE	LIQUID LEVEL MECHANISM/OVERFILL PROTECTION	LEAK DETECTION SYSTEMS AND/OR PROCEDURES	COMMENTS
With camp package	Camp back-up emergency generator day tank	Man-camp Central Pad	2005 (estimated)	TBD	TBD	Diesel	None	N/A	Manual [Note 2]	Local level indication	Visual surveillance	
With generator package in sub-base	CPF essential generator day tank	CPF Pad	2005 (estimated)	Non API	10 bbl	Diesel	None	N/A	Manual [Note 2]	Local level indication	Visual surveillance	
With generator package in sub-base	CPF essential generator day tank	CPF Pad	2005 (estimated)	Non API	10 bbl	Diesel	None	N/A	Manual [Note 2]	Local level indication	Visual surveillance	
With generator package in sub-base	CPF essential generator day tank	CPF Pad	2005 (estimated)	Non API	10 bbl	Diesel	None	N/A	Manual [Note 2]	Local level indication	Visual surveillance	
With firewater pump package	CPF diesel engine firewater pump day tank	CPF Pad	2005 (estimated)	UL 142	3 bbl	Diesel	Double wall tank construction	N/A	Manual [Note 2]	Local level indication	Visual surveillance	
TBD	Drilling Mud Tank 2A	Mud Plant Central Well Pad	2005 (estimated)	API 650	175 bbl	Drilling mud solution [Note 1]	Tanks located in mud processing area	Dike/liner	Manual	Local level indication	Visual surveillance	MI Drilling design; housed on grade
AIR STRIP	Possible Jet Fuel Storage Tank Vertical/skid	Air Strip	2005 (estimated)	API 650	20 bbl	Jet-A Aviation Fuel	See Note 3	Impermeable liner supported by timbers	Manual	Visual observation	Visual surveillance	
CPF PAD	Snow melt storage tank vertical/skid	Grind & Inject Facility	2006 (estimated)	Non API	100 bbl	Contaminated water	See Note 3	Impermeable liner supported by timbers	Manual	Visual observation	Visual surveillance	
TBD	Drilling Mud Tank 2B	Mud Plant Central Well Pad	2006 (estimated)	API 650	175 bbl	Drilling mud solution [Note 1]	Tanks located in mud processing area	Dike/liner	Manual	Local level indication	Visual surveillance	MI Drilling design; housed on grade

Notes:

- 1 May contain synthetic oils from drilling operations
- 2 Manual fill valve from truck loading line
- 3 Secondary containment will be provided for the largest single container plus sufficient freeboard for precipitation.

bbl Barrels
CPF Central Processing Facility

Does not include totes used for chemicals.

APPENDIX C

OIL POLLUTION ACT OF 1990 (OPA 90) ADDENDUM

U.S. Environmental Protection Agency (EPA)

U.S. Department of Transportation (DOT)

U.S. Coast Guard (USCG)

U.S. ENVIRONMENTAL PROTECTION AGENCY

**POINT THOMSON
OIL DISCHARGE PREVENTION AND CONTINGENCY PLAN**

**CROSS REFERENCE TO
U.S. ENVIRONMENTAL PROTECTION AGENCY
[40 CFR 112, APPENDIX F]**

REGULATION SECTION (Appendix F)	SECTION TITLE	PLAN SECTION NUMBER
1.1	Emergency Response Action Plan 112.20 (h)(1)	Section 1.1; Tables 1-1A and 1-1B
1.1.1	Qualified Individual Information	EPA Information Summary; Section 1.2.3; Table 1-2
1.1.2	Emergency Notification Phone List	Section 1.2; Table 1-2
1.1.3	Spill Response Notification Form	Section 1.2; Figure 1-3
1.1.4	Response Equipment List and Location	Section 3.6; Table 3-11
1.1.5	Response Equipment Testing and Deployment	Sections 1.5 and 3.6.2
1.1.6	Facility Response Team	Sections 1.1 and 1.2
1.1.7	Evacuation Plan	Maintained on-site at facility
1.1.8	Immediate Actions	Sections 1.1 and 1.2
1.1.9	Facility Diagram	Section 1.8
1.2	Facility Information 112.20 (h)(2)	EPA Response Plan Cover Sheet; Section 3.1
1.2.1	Facility Name and Location	EPA Response Plan Cover Sheet and Information Form; Section 3.1
1.2.2	Latitude and Longitude	EPA Response Plan Cover Sheet; <i>ACS Technical Manual, Volume 2, Map Atlas</i>
1.2.3	Wellhead Protection Area	Not Applicable
1.2.4	Owner/Operator	Section 3.1
1.2.5	Qualified Individual	EPA Information Summary; Section 1.2.3; Table 1-2
1.2.6	Date of Oil Storage Start-up	Section 3.1.2
1.2.7	Current Operation	Section 3.1.4
1.2.8	Dates and Type of Substantial Expansion	Not Applicable
1.3	Emergency Response Information 112.20 (h)(3)	Sections 1.1, 1.2, 3.3, 3.8, and 3.9
1.3.1	Notification	Sections 1.1, 1.2, and 3.3
1.3.2	Response Equipment List	Section 3.6; Table 3-11
1.3.3	Response Equipment Testing/Deployment	Sections 1.5 and 3.6

**POINT THOMSON
OIL DISCHARGE PREVENTION AND CONTINGENCY PLAN**

**CROSS REFERENCE TO
U.S. ENVIRONMENTAL PROTECTION AGENCY
[40 CFR 112, APPENDIX F] (CONTINUED)**

REGULATION SECTION (Appendix F)	SECTION TITLE	PLAN SECTION NUMBER
1.3.4	Personnel	Sections 1.5.2, 3.3, 3.8, and 3.9
1.3.5	Evacuation Plans	Maintained on-site at facility
1.3.6	Qualified Individual's Duties	Sections 1.2.3
1.4	Hazard Evaluation 112.20 (h)(4)	
1.4.1	Hazard Identification	Sections 2.3 and 2.4
1.4.2	Vulnerability Analysis	Section 3.10
1.4.3	Analysis of the Potential for an Oil Spill	Section 2.3
1.4.4	Facility Reportable Oil Spill History	Section 2.2
1.5	Discharge Scenarios 112.20 (h)(5)	Section 1.6.14
1.5.1	Small and Medium Discharges	Section 1.6.14
1.5.2	Worst-Case Discharge	EPA Response Plan Facility Cover Sheet and Information Form; Section 1.6.14
1.6	Discharge Detection Systems 112.20 (h)(6)	Section 2.5
1.6.1	Discharge Detection by Personnel	Section 2.5
1.6.2	Automated Discharge Detection	Section 2.5
1.7	Plan Implementation 112.20 (h)(7)	Introduction
1.7.1	Response Resources for Small, Medium, and Worst-Case Spills	Sections 1.6, 3.3, 3.5, 3.6, and 3.9
1.7.2	Disposal Plans	Sections 1.6.10 and 1.6.14
1.7.3	Containment and Drainage Planning	Sections 1.6.6, 1.6.14, and 3.2
1.8	Self-Inspection, Training, Meeting Logs 112.20 (h)(8)	Section 3.9
1.8.1	Facility Self-Inspection	Section 2.5.5
1.8.1.1	Tank Inspection	Section 2.5.5
1.8.1.2	Response Equipment Inspection	Section 3.6.2
1.8.1.3	Secondary Containment Inspection	Sections 2.1.11 and 2.5.5
1.8.2	Facility Drills/Exercises	Section 3.9
1.8.2.1	Qualified Individual Notification Drill Logs	Section 3.9
1.8.2.2	Spill Management Team Tabletop Exercise Logs	Section 3.9
1.8.3	Response Training	Section 3.9
1.9	Diagrams 112.20 (h)(9)	Section 1.8
1.10	Security 112.20 (h)(10)	Section 2.1.4

U.S. ENVIRONMENTAL PROTECTION AGENCY
RESPONSE PLAN COVER SHEET
Page 1 of 3

GENERAL INFORMATION

Owner/Operator of Facility: Exxon/Mobil Corporation

Facility Name: Point Thomson Gas Cycling Project

Facility Address (street address or route): 3301 C Street, Suite 400

The Point Thomson Unit is located on the North Slope of Alaska.

City, State, and U.S. Zip Code Anchorage, AK 99519-6601 (Mailing address)

Facility Phone No.: (907) 561-5331

Latitude (Degrees: North): 70° 08' to 70° 11'

Longitude (Degrees: West): 146° 04' to 146° 32'

Dun & Bradstreet Number: 00-121-3214

Standard Industrial Classification (SIC) Code: 1330

Largest Aboveground Oil Storage Tank Capacity (Gallons): 525,000

Maximum Oil Storage Capacity (Gallons): total volume of tanks

Number of Aboveground Oil Storage Tanks: 24

Worst-Case Oil Discharge Amount (Gallons):

525,000 gallon tank +42,697,410 gallons from blowout = 43,222,410 gallons

Facility Distance to Navigable Water. Mark the appropriate line.

0-1/4 mile X 1/4-1/2 mile 1/2-1 mile >1 mile

U.S. ENVIRONMENTAL PROTECTION AGENCY
RESPONSE PLAN COVER SHEET
Page 2 of 3

APPLICABILITY OF SUBSTANTIAL HARM CRITERIA

Facility Name: Point Thomson

Does the facility transfer oil over-water to or from vessels, and does the facility have a total oil storage capacity greater than or equal to 42,000 gallons?

Yes X
No

Does the facility have a total oil storage capacity greater than or equal to 1 million gallons, and does the facility lack secondary containment that is sufficiently large to contain the capacity of the largest aboveground oil storage tank plus sufficient freeboard to allow for precipitation within any aboveground oil storage tank area?

Yes
No X

Does the facility have a total oil storage capacity greater than or equal to 1 million gallons, and is the facility located at a distance (as calculated using the appropriate formula in Appendix C or a comparable formula) such that a discharge from the facility could cause injury to fish and wildlife and sensitive environments?

Yes X
No

Does the facility have a total oil storage capacity greater than or equal to 1 million gallons, and is the facility located at a distance (as calculated using the appropriate formula in Appendix C or a comparable formula) such that a discharge from the facility would shut down a public drinking water intake?

Yes
No X

Does the facility have a total oil storage capacity greater than or equal to 1 million gallons, and has the facility experienced a reportable oil spill in an amount greater than or equal to 10,000 gallons within the last 5 years?

Yes
No X

**U.S. ENVIRONMENTAL PROTECTION AGENCY
RESPONSE PLAN COVER SHEET**

Page 3 of 3

CERTIFICATION

I certify under penalty of law that I have personally examined and am familiar with the information submitted in this document, and that based on my inquiry of those individuals responsible for obtaining information, I believe that the submitted information is true, accurate, and complete.

Signature: _____

Name (Please type or print): Randy F. Buckley

Title: Project Manager

Date: _____

THIS PAGE INTENTIONALLY LEFT BLANK

U.S. EPA INFORMATION SUMMARY

Name and Address of Operator

ExxonMobil
3301 C Street, Suite 400
Anchorage, AK 99503

P.O. Box 196601
Anchorage, AK 99519
(907) 561-5331

Name and Telephone Number of Qualified Individual

The Qualified Individuals information will be updated prior to construction activities.

Primary

Chris Faulk
Production Field Superintendent
800 Bell Street
Houston, TX 77002
(713) 656-3986

Alternate

Chuck McClain
Production Operations Superintendent
800 Bell Street
Houston, TX 77002
(713) 656-3703

Worst-Case Discharge

The worst-case discharge (WCD) for a well is calculated using the method outlined in 40 CFR 112, Appendix D, Attachment D-1, Method B2, for wells deeper than 10,000 feet. The well blowout discharge is estimated at 27,000 barrels per day (bpd) of gas condensate for the first 2 hours when the well is ignited. After Hour 2 (0.083 day), the well is ignited, removing 26,973 bpd (99.9 %) of the oil. Mechanical response actions commence 6 hours (0.25 day) after the blowout, resulting in an additional 5,332 bpd of recovery capacity. The equation for calculating the WCD for the well is:

$$\text{WCD Well} = \text{Discharge Volume 1} + \text{Discharge Volume 2}$$

Where:

$$\begin{aligned} \text{Discharge Volume 1} &= (\text{days unattended} + \text{days to respond}) \times (\text{rate of well}) \\ &= (0 \text{ day} + 0.25 \text{ day}) \times (27,000 \text{ bpd}) \\ &= 0.25 \text{ day} \times 27,000 \text{ bpd} = 6,750 \text{ bbl} \end{aligned}$$

$$\begin{aligned} \text{Discharge Volume 2} &= [45 \text{ days} - (\text{days unattended} + \text{days to respond})] \times (\text{rate of well}) \\ &\quad \times (\text{rate of well}/\text{rate of recovery}) \\ &= [45 \text{ days} - (0 \text{ day} + 0.25 \text{ day})] \times (27,000 \text{ bpd}) \\ &\quad \times (27,000 \text{ bpd}/32,305 \text{ bpd}) \\ &= (44.75 \text{ days} \times 27,000 \text{ bpd} \times 0.8358) = 1,009,855 \text{ bbl} \end{aligned}$$

$$\text{WCD Well} = 6,750 \text{ barrels} + 1,009,855 \text{ barrels} = 1,016,605 \text{ barrels or } 42,697,410 \text{ gallons}$$

The rate of recovery includes the oil recovery capacities identified in Table 1-44 (5,332 bpd) and the volume of oil removed by ignition (26,973 bpd).

The WCD for the largest tank is 525,000 gallons (12,500 bbl) of diesel.

Combining the two WCDs results in a volume of 43,222,410 gallons of hydrocarbon material.

Basis for Determination of Significant and Substantial Harm

Point Thomson operations will have the potential to spill hydrocarbon material on tundra (wetlands) and into navigable waters of the United States. As such, it is determined to pose significant and substantial harm should a spill occur.

The Alaska Clean Seas (ACS) *Technical Manual* presents a summary of major spill response equipment which will be available to ExxonMobil on the North Slope through ExxonMobil's contract with ACS. In addition, other spill response equipment will be available through a mutual aid agreement with other North Slope operators.

ACS
Tactics L-4
and L-8

**POINT THOMSON DEVELOPMENT AREA
OIL DISCHARGE PREVENTION AND CONTINGENCY PLAN**

**CROSS REFERENCE TO
U.S. ENVIRONMENTAL PROTECTION AGENCY
SPILL PREVENTION, CONTROL AND COUNTERMEASURE REGULATIONS
[40 CFR 112.7 to 40 CFR 112.10]**

REGULATION SECTION	SECTION TITLE	PLAN SECTION NUMBER
112.7	General Requirements for Spill Prevention, Control and Countermeasure (SPCC) Plans	
112.7(a)(3)	Describe layout of facility and include facility diagram showing location of and contents of each container.	Sections 1.8 and 3.1
112.7(a)(3)(i)	List the type of oil in each container and its capacity.	Appendix B
112.7(a)(3)(ii)	Discharge prevention measures including procedure for routine handling of products.	Sections 2.1.5, 2.1.6, 2.1.8, and 2.5; Appendix A
112.7(a)(3)(iii)	Discharge, procedures or drainage controls such as secondary containment around containers and other structures.	Sections 2.5, 2.1.10, 2.1.11 and this section
112.7(a)(3)(iv)	Countermeasures for discharge discovery, response, and cleanup.	Sections 2.5 and 1.6.14
112.7(a)(3)(v)	Methods of disposal of recovered materials in accordance with applicable legal requirements	Sections 1.6.10 and 1.6.14
112.7(a)(3)(vi)	Contact list and phone numbers for the facility response coordinator, National Response Center, cleanup contractors and all appropriate federal, state and local agencies.	Sections 1.1 and 1.2; Tables 1-1B 1-2, and 1-3
112.7(b)	Prediction of the direction, rate of flow, and total quantity of oil which could be discharged.	Sections 1.6.13, 1.6.14, and 1.8; <i>ACS Technical Manual, Volume 2, Map Atlas</i>
112.7(c) and (d)	Provide appropriate containment and/or diversionary structures or equipment to prevent a discharge, OR explain why this is not practicable.	This section and Sections 2.1.5, 2.1.6, 2.1.10, and 2.1.11
112.7(d)(2)	A written commitment of manpower, equipment and materials required to expeditiously control and remove any quantity of oil discharged.	Management Approval and Manpower Authorization Form (p. i); Sections 3.5 and 3.6
112.7(e)	Conduct inspection and tests required by this part in accordance with written procedures.	Sections 2.5.5, and 3.6.2; Table 2-2
112.7(f)(1)	Train oil-handling personnel in the operation and procedures, pollution control laws, facility operations, SPCC plan and maintenance of equipment to prevent discharges.	Section 2.1
112.7(f)(2)	Designate a person who is accountable for discharge prevention.	Section 1.1
112.7(f)(3)	Conduct discharge prevention briefings for oil-handling personnel at least once a year.	Section 2.1
112.7(g)(1)	Fully fence each facility handling, processing, or storing oil, and lock and guard entrance gates.	Section 2.1.4

**POINT THOMSON DEVELOPMENT AREA
OIL DISCHARGE PREVENTION AND CONTINGENCY PLAN**

**CROSS REFERENCE TO
U.S. ENVIRONMENTAL PROTECTION AGENCY
SPILL PREVENTION, CONTROL AND COUNTERMEASURE REGULATIONS
[40 CFR 112.7 to 40 CFR 112.10] (CONTINUED)**

REGULATION SECTION	SECTION TITLE	PLAN SECTION NUMBER
112.7(g)(2)	Ensure that the master flow and drain valves and any other valves have security measures so that they remain in the closed position when not operating.	None; see table entry to the left
112.7(g)(3)	Lock the starter control on each oil pump in the "off" position and locate it at a site accessible only to authorized personnel when not operating.	None; see table entry to the left
112.7(g)(4)	Securely cap the blank-flange of the loading/unloading connections of oil pipelines or facility piping when not in service.	Section 2.1.9
112.7(g)(5)(i) and (ii)	Provide facility lighting commensurate with the type and location of the facility that will assist in the discovery of discharges occurring during darkness hours and prevent discharges occurring from acts of vandalism.	See Section 2.1.4 and Section 3.1 for equivalent environmental protection
112.7(h)(1)	Use quick drainage system for tank car or tank truck loading/unloading areas, designed to hold the maximum capacity of any single compartment of a tank car or tank truck.	Sections 2.1.5 and 2.5; Appendix A
112.7(h)(2)	Provide interlocked warning light or physical barrier system, warning signs, wheel chocks or vehicle brake interlock system in loading/unloading areas to prevent movement.	This section and Section 2.1.5; Appendix A
112.7(h)(3)	Prior to filling or departure of any tank car or tank truck, inspect for discharges on all outlets of vehicles and ensure they are tightened.	Section 2.1.5; Appendix A
112.7(i)	If a field-constructed, aboveground container is repaired or changes service that might affect the risk of a discharge due to brittle fracture, or has discharged due to brittle fracture, evaluate the container for risk of discharge and take appropriate action.	None; see table entry to the left
112.7(j)	Include a complete discussion on conformance with the applicable requirements and other effective discharge prevention and containment procedures listed in this part or any more stringent state rules, regulations and guidelines.	This section

**POINT THOMSON DEVELOPMENT AREA
OIL DISCHARGE PREVENTION AND CONTINGENCY PLAN**

**CROSS REFERENCE TO
U.S. ENVIRONMENTAL PROTECTION AGENCY
SPILL PREVENTION, CONTROL AND COUNTERMEASURE REGULATIONS
[40 CFR 112.7 to 40 CFR 112.10] (CONTINUED)**

REGULATION SECTION	SECTION TITLE	PLAN SECTION NUMBER
112.8	Spill Prevention, Control and Countermeasure Plan requirements for onshore facilities (excluding production facilities)	
112.8(b)(3) and (4)	Design facility drainage systems from undiked areas (such as where piping is located outside containment walls or where tank truck discharges may occur outside the loading area) to flow into ponds, lagoon or catchment basins. If drainage is not engineered as above, equip the final discharge of all ditches inside the facility with a diversion system.	Sections 1.8 and 3.1
112.8(c)(1)	Do not use a container for storage unless it is compatible with the material stored.	Sections 2.1.10
112.8(c)(2)	Construct all bulk storage container installation so secondary containment is provided for the entire capacity of the largest single container with sufficient freeboard for precipitation and is impervious	This section and Sections 2.1.10 and 2.1.11; Appendix B
112.8(c)(6)	Test each aboveground container for integrity on a regular schedule.	Section 2.1.10
112.8(c)(8)(i) through (v)	Engineer or update each container installation with good engineering practices and provide one of the following: high-liquid level alarms, high-liquid level pump cutoff device, direct audible or code communication, fast response system for determining the liquid level of each bulk storage container, or regularly test liquid-level devices.	Sections 2.1.10 and 4.8; Appendix B
112.8(c)(10)	Promptly correct visible discharges which result in loss of oil from a container and promptly remove any accumulations of oil in diked areas.	Sections 2.1.5 and 2.1.6
112.8(d)(1)	Provide buried piping installed or replaced after August 16, 2002 with protective wrapping and coating.	Sections 2.1.9 and 4.9
112.8(d)(2)	Cap or blank-flange terminal connection at the transfer point and mark it as to origin when piping is not in service.	Sections 2.1.6 and 2.1.9
112.8(d)(3)	Properly design pipe supports to minimize abrasion and corrosion and allow expansion and contraction.	Section 2.1.9
112.8(d)(4)	Regularly inspect all aboveground valves, piping, and appurtenances.	Section 2.1.9; Table 2-2
112.8(d)(5)	Warn vehicles entering the facility so that vehicles will not endanger aboveground piping	Section 2.1.9

**POINT THOMSON DEVELOPMENT AREA
OIL DISCHARGE PREVENTION AND CONTINGENCY PLAN**

**CROSS REFERENCE TO
U.S. ENVIRONMENTAL PROTECTION AGENCY
SPILL PREVENTION, CONTROL AND COUNTERMEASURE REGULATIONS
[40 CFR 112.7 to 40 CFR 112.10] (CONTINUED)**

REGULATION SECTION	SECTION TITLE	PLAN SECTION NUMBER
112.9	Spill Prevention, Control and Countermeasure Plan requirements for onshore oil production facilities	
112.9(c)(1)	Do not use a container for the storage of oil unless material and construction are compatible.	Section 2.1.10; Appendix B
112.9(c)(2)	Provide secondary containment for entire capacity of largest single container and sufficient freeboard.	Section 2.1.11; Appendix B
112.9(c)(3)	Periodically, and upon regular schedule, visually inspect each container for deterioration and maintenance needs.	Section 2.1.10; Table 2-2; Appendix B
112.9(c)(4)(i)	Container capacity is adequate to assure container will not overflow if pumper/gauger is delayed in making regularly scheduled rounds.	Section 4.8; Appendix A; this table entry
112.9(c)(4)(ii)	Overflow equalizing lines between containers so that full container can overflow into adjacent container.	Not Applicable
112.9(c)(4)(iii)	Vacuum protection is adequate to prevent container collapse during a pipeline run or other transfer of oil from the container.	This table entry
112.9(c)(4)(iv)	High-level sensors generate and transmit an alarm signal to the computer where facility is subject to computer production control system.	Appendix B
112.9(d)(1)	Periodically, and upon regular schedule, inspect all aboveground valves and piping associated with transfer operations.	Table 2-2
112.9(d)(3)	Point Thomson has a program of flowline maintenance to prevent discharges.	Sections 2.1.8 and 2.1.9

SPCC Conformance Discussion

General Conformance. The facility's general conformance with the Title 40, Code of Federal Regulations Part 112 requirements is discussed in this section. A complete discussion of conformance with the applicable federal and state regulations for oil spill prevention and containment as required by 40 CFR 112.7(j) is provided in the Oil Discharge Prevention and Contingency Plan (plan). For prevention procedures, see Sections 2 and 4 in particular, including documents incorporated by reference into the plan. For spill containment tactics, see Sections 1, 2, 3, and 4 of the plan. The plan shows how the generally more stringent state oil spill prevention and containment regulations are met.

The facility will conform with the requirements of Parts 112.3 to 112.9 that apply to it as an onshore, non-transportation-related, oil production and non-production facility.

Spill Trajectories. The oil spill trajectory of each type of potential major spill has been anticipated, as required by 40 CFR 112.7(b). The quantities of the potential spills are equal to capacities of the containers. See the simulated oil spill volume calculations for federal worst-case discharges in the OPA 90 sections and for state Response Planning Standards in Section 1.6.13. Also see the discharge analysis table in Section 2 of the plan. The pad diagrams in Section 1.8 of the plan and ACS *Technical Manual, Volume 2*, Map Atlas provide surface drainage diagrams that illustrate potential spill paths. The atlas is incorporated into the SPCC plan by reference.

Spills from most fixed tanks will be confined by facility module floors and their spill drainage systems or by outdoor, lined-and-diked areas. At loading areas, spills will move across gravel pads toward dikes.

Oil pipelines can spill oil to gravel pads, tundra, or streams. The trajectories would spread from the pipeline rupture, moving down-slope or taking the form of aerial spray. Large ruptures could spill the quantity of oil from between valves minus the oil retained in the piping by terrain effects.

Fueling Areas. At tank truck loading/unloading areas, transfers of fuel will follow Slope-wide standard operating procedures (see Appendix A of the plan). The procedures have been found very effective in reducing spills at loading racks under conditions and with the equipment characteristic of the Alaska North Slope. The result of the fuel transfer procedures is spill prevention protection equivalent to the vehicle departure cautions described in 40 CFR 112.7(h)(2). For more details, see the discussions of fuel loading/unloading areas in Section 2.

Mobile Tanks Less than 660 Gallons. Fixed surface dikes and curbing for small, mobile oil tanks that are frequently moved among sites near water will not be provided because they are not practicable. For example, bleed trailers, light plants and heaters will be pulled from well to well as part of well-servicing operations. Short-term dikes, berms, and walls are generally not feasible because of the limited time the tank would be on location and the limited available space on the gravel pad. Furthermore, surface structures, including drainage systems and barriers, would pose hazards to other traffic.

However, most small mobile tanks will have built-in curbing or trays to contain spills. The curbing will meet the containment requirement in Part 112.7. The tanks will be visually inspected for deterioration and maintenance needs as required by Part 112.9(c)(3). The tanks will not be required by SPCC regulations to undergo integrity tests, although they will undergo testing, or to have secondary containment such as fixed surface dikes and curbing with capacity equal to the container.

Spills from drums and small tanks that are set back from the pad edge are expected to be retained in gravel pads and not reach water. Small tanks with neither built-in nor ground curbing, e.g., Tioga heaters, will be placed on gravel pads well away from the edge. The gravel provides sorbency [(Part 112.7(c)(vii))] and catchment [Parts 112.8(c)(2) and 112.9(c)(2)] and retains the spill before it reaches water. For example, spills of 660 gallons will be expected to spread over approximately 1,320 square feet at the rate of up to one-half gallon per square foot. That rate assumes 3 foot gravel depth and 5% available porosity, reduced by half to account for ice and water [(27 cubic feet per cubic yard x 0.05 void space x 7.5 gallons

per cubic foot / 9 square feet surface per cubic yard) x 0.5 for water and ice = 0.56 gallon per square foot]. Twenty feet is the radius of such a spill if it spreads as a circle.

Deviation from Secondary Containment. Oil spill prevention is provided for pipelines and some small tanks as described in Part 112.7(d) rather than by secondary containment methods described in Part 112.7(c)(2).

Pipelines. Secondary containment systems described in Part 112.7(c)(2) are not practicable for oil pipelines outside of modules. Oil pipelines form networks of hundreds of miles on the North Slope. The pipelines are elevated above tundra, ponds and streams. The surfaces beneath the pipelines are not suitable for secondary containment systems. Accumulations of ice and snow, and the effects of high winds and seasonal flooding, generally preclude the long-term use of surface structures other than gravel pads or metal pilings. Secondary containment structures for pipelines above gravel pads would be subject to similar ice, snow, and wind effects as well.

Pipelines will be inspected and maintained to prevent oil spills to tundra and water as described in Sections 2 and 4 of the plan.

Mobile Tanks. Those mobile bulk storage containers that might spill from the pad edge to water, and will not have the prevention systems described in Part 112.7(c) instead will receive periodic integrity testing. Their associated piping and valves will receive periodic testing of integrity and leaks in accordance with Part 112.7(d). The tanks will be managed under a comprehensive integrity management program carried out by ExxonMobil's corrosion engineers group. The testing will follow standard operating procedures developed and implemented by the facility's corrosion inspectors and field surveillance teams. The inspections, tests, and records will follow Part 112.7(e) requirements. Furthermore, the facility will have an oil spill contingency plan and a written commitment for spill response as described in Parts 112.7(d)(1) and (2). The inspection alternative that will be applied to mobile tanks, as well as to pipelines as described above, complies with the deviation requirements of Parts 112.7, 112.8 and 112.9 for preventing spills from reaching water.

Liquid Level Determination. Liquid level determination for mobile tanks at non-production facilities, required by Part 112.8(c)(8), will be conducted by the voice and signal method described in Part 112.8(c)(8)(iii). See the liquid level determination best available technology discussion in Section 4 of the plan. At production facilities, small tank overflow protection will be provided by adequate container capacity relative to the pumper's schedule as described in Part 112.9(c)(4)(i). For more details, see the overflow protections list in the plan appendices.

U.S. DEPARTMENT OF TRANSPORTATION

**POINT THOMSON
OIL DISCHARGE PREVENTION AND CONTINGENCY PLAN**

**CROSS REFERENCE TO
U.S. DEPARTMENT OF TRANSPORTATION RESPONSE PLAN REQUIREMENTS
[49 CFR 194, Subpart B]**

REGULATION SECTION (49 CFR)	SECTION TITLE	PLAN SECTION
194.103	Significant and Substantial Harm; Operator's Statement	
(a)	Identification of line sections that might cause significant and substantial harm to the environment in the event of a discharge	DOT Information Summary
194.105	Worst-Case Discharge	
(a)	The worst-case discharge and the methodology, including calculations, used to arrive at the volume	DOT Information Summary
194.107	General Response Plan Requirements	
(a)	Resources for responding, to the maximum extent practicable, to a worst-case discharge and to the substantial threat of such a discharge	Sections 1.6 and 3.5 through 3.10
(c)	Certification that the response plan is consistent with the National Contingency Plan (NCP)	Page DOT-3
(d)(1)(i)	Information summary as required by 194.113	DOT Consistency Certification and DOT Information Summary
(d)(1)(ii)	Immediate notification procedures	Sections 1.1, 1.2, and 3.3
(d)(1)(iii)	Spill detection and mitigation procedures	Section 2.5
(d)(1)(iv)	Name, address, and telephone number of oil spill response organization	Table 1-2
(d)(1)(v)	Response activities and response resources	Sections 1.1, 1.2, 1.5, 1.6, 3.3, and 3.6
(d)(1)(vi)	Names and telephone numbers of federal, state, and local agencies with pollution control responsibilities or support	Section 1.2; Table 1-3
(d)(1)(vii)	Training procedures	Sections 2.1.1 and 3.9
(d)(1)(viii)	Equipment testing	Section 3.6.2
(d)(1)(ix)	Drill types, schedules, and procedures	Section 3.9
(d)(1)(x)	Plan review and update procedures	Introduction
(d)(2)	Response zone appendices	Not Applicable

THIS PAGE INTENTIONALLY LEFT BLANK

U.S. DOT CERTIFICATION OF PREPAREDNESS

CERTIFICATE OF RESPONSE PREPAREDNESS FOR POINT THOMSON

EXXONMOBIL
POINT THOMSON CONDENSATE EXPORT PIPELINE

Pipeline Response Plans Officer
Research and Special Programs Administration
U.S. Department of Transportation
Room 2335
400 Seventh Street, SW
Washington, DC 20590

ExxonMobil hereby certifies to the Research and Special Programs Administration of the DOT that it has identified, and ensured by contract, or other means to be approved by the Research and Special Programs Administration, the availability of private personnel and equipment to respond, to the maximum extent practicable, to a worst-case discharge or a substantial threat of such a discharge.

Randy F. Buckley
Project Manager
ExxonMobil Development Company, on behalf of Exxon Mobil Corporation

Date

This Certification of Response Preparedness was acknowledged before me on _____, by
_____ on behalf of said corporation.

My commission expires _____

THIS PAGE INTENTIONALLY LEFT BLANK

ACP/NCP CONSISTENCY CERTIFICATION FOR POINT THOMSON

EXXONMOBIL
POINT THOMSON CONDENSATE EXPORT PIPELINE

ExxonMobil hereby certifies to the Research and Special Programs Administration of the DOT that it has reviewed the National Contingency Plan (NCP) and applicable Area Contingency Plans (ACPs) and found the Point Thomson ODPCP to be consistent with them. The NCP/ACPs reviewed include the NCP as set forth in 40 CFR 300 as published in Federal Register Volume 59, No. 178, Final Rule, September 15, 1994, and the Alaska Federal/State Unified Preparedness Plan ACP (The Unified Plan), Volume I and Volume II (North Slope Borough), dated September 1999.

Randy F. Buckley
Project Manager
ExxonMobil Development Company,
on behalf of Exxon Mobil Corporation

Date

THIS PAGE INTENTIONALLY LEFT BLANK

U.S. DOT INFORMATION SUMMARY

Name and Address of Operator

ExxonMobil
P.O. Box 196601
Anchorage, AK 99519
(907) 561-5331

Street Address:
3301 C Street, Suite 400
Anchorage, AK 99503
Fax: (907) 564-3789

Response Zone Description

Point Thomson consists of a single response zone containing the Point Thomson condensate export pipeline that runs from the Point Thomson Central Processing Facility (CPF) to the Badami pipeline, located in the North Slope Borough of Alaska.

Name and Telephone Number of Qualified Individual

The Qualified Individuals information will be updated prior to construction activities.

Primary

Chris Faulk
Production Field Superintendent
800 Bell Street
Houston, TX 77002
(713) 656-3986

Alternate

Chuck McClain
Production Operations Superintendent
800 Bell Street
Houston, TX 77002
(713) 656-3703

Worst-Case Discharge

In accordance with 49 CFR 194.105(b)(1), the worst-case discharge (WCD) for the pipeline is equal to the pipeline's maximum release time (RT_{max}) in hours plus the maximum shutdown response time (ST_{max}) in hours multiplied by the maximum flow rate (F_{max}) expressed in barrels per hour (bph) (based on maximum daily capacity of the pipeline) plus the largest pipeline drainage volume (PV_{max}) after shutdown of the line section(s) in the response zone expressed in barrels or:

$$WCD = [(RT_{max} + ST_{max}) * F_{max}] + PV_{max}$$

$$WCD = 16,899 \text{ bbl condensate}$$

Where:

$$RT_{max} = 0.05 \text{ hours (3minutes)}$$

$$ST_{max} = 0.083 \text{ hours (5 minutes)}$$

$$F_{max} = 4167 \text{ bph (100,000 barrels of oil per day [bopd] / 24 hours per day [hpd])}$$

$$PV_{max} = 16,345 \text{ bbl condensate} = [((12.75\text{-inch outside diameter} - 2 \times 0.28\text{-inch (wall thickness) / 2})^2 \times 3.14) / 144 \text{ square inches per square foot}] / (5.6 \text{ cubic foot / bbl}) \times (21.4 \text{ miles}) \times (5280 \text{ ft/mile}) = 16,345 \text{ bbl}$$

Therefore:

$$WCD = [(0.05 + 0.083) * 4167] + 16,345 = 16,899 \text{ bbl of condensate}$$

Time to detect a leak and to shut in the pipeline is not affected by adverse weather.

Description of the Line Sections

The condensate export pipeline will be 22 miles in length running between valves at the CPF and Badami Development Area.

Basis for Determination of Significant and Substantial Harm

The condensate export pipeline will run across several streams and over wetlands. As such, it is determined to pose significant and substantial harm should a spill occur.

Certification of Response Personnel and Equipment

Sufficient response personnel and equipment will be available to respond to a WCD or threat of such a discharge. Information is provided in Sections 1.6.14, Response Scenarios; 3.5, Logistical Support; 3.6, Response Equipment; and 3.8, Response Contractor Information.

Substantial Threat

Events and conditions that can pose a substantial threat of a WCD and procedures to eliminate or mitigate threat of a discharge are identified in ExxonMobil's "Point Thomson USDOT Operations Manual", Part III, Abnormal Operations. The Point Thomson condensate export pipeline will cross several small streams and wetlands to the Badami Development Area pipeline tie-in. According to the requirements of 49 CFR 194.103, and the definitions in 49 CFR 194.103(c)(5) this line section can be expected to cause significant and substantial harm to the environment in the event of a discharge of condensate.

U.S. COAST GUARD

**POINT THOMSON
OIL DISCHARGE PREVENTION AND CONTINGENCY PLAN**

**CROSS REFERENCE TO
U.S. COAST GUARD RESPONSE PLAN REQUIREMENTS
[33 CFR 154.1035]**

REGULATION SECTION (33 CFR 154.1035)	SECTION TITLE	PLAN SECTION
(a)	Introduction and Plan Content	
(a)(1)	Facility name, address, telephone and fax numbers, mailing address	Introduction; Section 1.1
(a)(2)	Facility's geographic location	Sections 1.8 and 3.1
(a)(3)	24-hour procedure for contacting facility owner or operation	Sections 1.1 and 1.2
(a)(4)	Table of contents	Table of Contents
(a)(5)	Cross-index	This section
(a)(6)	Record of changes	Page iii
(b)	Emergency Response Action Plan	
(b)(1)	Notification procedures	Sections 1.1 and 1.2
(b)(1)(i)(A)	Facility response personnel, the spill management team, Oil Spill Removal Organization (OSRO), and the qualified individual(s) and the designated alternate(s)	Sections 1.1, 1.2, and 1.5; Table 1-2
(b)(1)(i)(B)	Government agencies	Table 1-3; Section 1.2.2
(b)(1)(ii)	Notification form	Section 1.2; Figure 1-3
(b)(2)	Facility's Spill Mitigation Procedures	This section; Sections 1.6, 2.1 and 2.5; Appendix A
(b)(2)(i)(A)	Average most probable discharge	This section
(b)(2)(i)(B)	Maximum most probable discharge	This section
(b)(2)(i)(C)	Worst-case discharge	This section
(b)(2)(i)(D)	Worst-case discharge from non-MTR portion of facility	This section and Section 1.6.14
(b)(2)(ii)	Mitigation or prevention procedures for discharges or threat of discharge	Sections 1.6, 2.1, 2.3, and 2.5; Appendix A
(b)(2)(ii)(A)	Failure of manifold, loading arm, hoses, other	Appendix A
(b)(2)(ii)(B)	Tank overfill	Sections 2.1.10 and 2.5
(b)(2)(ii)(C)	Tank failure	Sections 1.6.14 and 2.5
(b)(2)(ii)(D)	Piping rupture	Sections 1.6.14, 2.5 and 2.1.8
(b)(2)(ii)(E)	Piping leak	Sections 1.6.1, 2.1.8, and 2.5
(b)(2)(ii)(F)	Explosion or fire	Section 1.6.2
(b)(2)(ii)(G)	Equipment failure	Section 1.6.1

**CROSS REFERENCE TO
U.S. COAST GUARD RESPONSE PLAN REQUIREMENTS
[33 CFR 154.1035] (CONTINUED)**

REGULATION SECTION (33 CFR 154.1035)	SECTION TITLE	PLAN SECTION
(b)(2)(iii)	List of equipment and responsibilities for mitigation of average most probable discharge	Sections 1.1, 2.1.5, and 3.6; Appendix A
(b)(3)	Facility Response Activities	Sections 1.1 and 1.2
(b)(3)(i)	Facility personnel's responsibilities to initiate and supervise response pending arrival of Qualified Individual	Sections 1.1, 1.2, and 3.3
(b)(3)(ii)	Qualified Individual's responsibility and authorities	Sections 1.1 and 1.2
(b)(3)(iii)	Organizational structure to manage response actions	Sections 1.1, 1.2, and 3.3
(b)(3)(iv)	Oil spill removal organization(s) and spill management team capabilities	Tables 1-1B and 1-2; Sections 3.8 and 3.9
(b)(3)(iv)(A)(1)	Provide equipment and supplies for average most probable discharge	Section 3.6
(b)(3)(iv)(A)(2)	Trained personnel for 7 days	Sections 3.5 and 3.9
(b)(3)(iv)(B)	Job descriptions for each spill management team member within the organization structure	Sections 1.1 and 1.2
(b)(4)	Fish and wildlife and sensitive environments	Sections 1.6.5, 1.6.11, 1.6.14, and 3.2
(b)(4)(i)	Identification of environmentally sensitive areas potentially impacted by a worst-case discharge	Sections 1.6.5 and 1.6.14
(b)(4)(ii)(A)	List of sensitive areas potentially impacted by a worst-case discharge	Sections 1.6.14 and 3.2
(b)(4)(ii)(B)	Procedures to protect sensitive areas	Sections 1.6.14 and 3.2
(b)(4)(ii)(C)	Depict response actions on map	Section 1.6.14
(b)(4)(iii)(A)	Personnel and equipment to protect sensitive areas for distance and days per Table 2, Appendix C, 33 CFR 154	Section 1.6.14
(b)(4)(iii)(B)(1)(i)	For persistent oil and non-petroleum oils discharged into non-tidal waters, the distance from the facility traveled in 48 hours at maximum current	Not Applicable
(b)(4)(iii)(B)(1)(ii)	For persistent oil and non-petroleum oils discharged into tidal waters, 15 miles from the facility down current during ebb tide and to the point of maximum tidal influence or 15 miles, whichever is less, during flood tide.	5 miles on east and west of barge mooring location
(b)(4)(iii)(B)(1)(iii)	For non-persistent oil discharged into non-tidal waters, the distance from the facility traveled in 24 hours at maximum current	Section 3.1; <i>ACS Technical Manual, Volume 2</i>
(b)(4)(iii)(B)(1)(iv)	For non-persistent oil discharged into tidal waters, 5 miles from the facility down current during ebb tide and to the point of maximum tidal influence or 5 miles, whichever is less, during flood tide.	5 miles on east and west of barge mooring location
(b)(4)(iii)(B)(2)	Trajectory model (substitute for distance calculation required by [b][4][iii][B][1])	Section 1.6.4
(b)(5)	Disposal plan	Section 1.6.10
(c)	Training and Exercises	
(c)(1)	Training procedures	Sections 2.1.1 and 3.9
(c)(2)	Exercise procedures	Section 3.9

**CROSS REFERENCE TO
U.S. COAST GUARD RESPONSE PLAN REQUIREMENTS
[33 CFR 154.1035] (CONTINUED)**

REGULATION SECTION (33 CFR 154.1035)	SECTION TITLE	PLAN SECTION
(d)	Plan Review and Update Procedures	Introduction
(e)	Appendices	
(e)(1)(i)	Physical description of facility	Section 3.1
(e)(1)(ii)	Identify the sizes, types, and number of vessels that the facility can transfer oil to and from simultaneously	Not Applicable
(e)(1)(iii)	Location of First Valve in Secondary Containment	Section 1.8
(e)(1)(iv)	Information on oil handled, stored, or transported at the facility in bulk	MSDS will be available in the <i>Fuel Transfer Operations Manual</i> , maintained at the facility.
(e)(2)	List of contacts	Sections 1.1 and 1.2; Table 1-2
(e)(2)(i)	24-hour contact for Qualified Individual and alternate	Section 1.2.3; Table 1-2
(e)(2)(ii)	24-hour contact for oil spill response organization(s)	Section 1.2; Tables 1-1B and 1-2
(e)(2)(iii)	24-hour contact for agencies	Section 1.2; Table 1-3
(e)(3)(i)	Equipment and Personnel for Response of Average Most Probable Discharge	Sections 1.6.14 and 3.6
(e)(3)(ii)	Equipment list belonging to OSRO to respond to a most probable or worst-case discharge	Section 3.6 and <i>ACS Technical Manual, Volume 1, Tactic L-6</i>
(e)(3)(iii)	If OSRO has been classified by USCG, equipment list is not required but classification must be noted	Section 3.6
(e)(4)	Communications Plan	Section 1.4
(e)(5)	Site-specific Health and Safety Plan	<i>ACS Technical Manual, Volume 2, Tactics S1 to S6.</i>
(e)(6)	List of Acronyms and Definitions	Table of Contents

THIS PAGE INTENTIONALLY LEFT BLANK

POTENTIAL DISCHARGES

Average Most Probable Discharge

The average most probable discharge is calculated as approximately 0.6 bbl of diesel fuel, based on the definition contained in 33 CFR 154.1020 (the lesser of 50 bbl or 1% of the volume of the WCD).

Maximum Most Probable Discharge

The maximum most probable discharge is 5.7 bbl of diesel fuel, based on the definition contained in 33 CFR 154.1020 (the lesser of 1,200 bbl or 10 % of the volume of the WCD).

Worst-Case Discharge

In accordance with 33 CFR 154.1029(b)(2), the WCD for piping between the marine transfer manifold and the non-transportation-related portion of the facility is equal to the pipeline's maximum release time (RT_{max}) in minutes; plus the maximum shutdown response time (ST_{max}) in minutes; multiplied by the maximum flow rate (F_{max}) expressed in barrels per minute; plus the largest line drainage volume (PV_{max}), expressed in barrels, for the pipe or hose between the marine manifold and the non-transportation-related portion of the facility:

$$WCD = [(RT_{max} + ST_{max}) * F_{max}] + PV_{max}$$
$$WCD = 57.25 \text{ bbl diesel}$$

Where:

$$\begin{aligned} RT_{max} &= 2 \text{ minutes} \\ ST_{max} &= 0.5 \text{ minutes} \\ F_{max} &= 10.5 \text{ bbl per minute} \\ PV_{max} &= 31 \text{ bbl (based on 2,000 feet of 4-inch diameter hose)} \end{aligned}$$

Therefore, the WCD is:

$$[(2 \text{ min} + 0.5 \text{ min}) * 10.5 \text{ bbl/min}] + 31 \text{ bbl} = 57.25 \text{ bbl of diesel oil}$$