

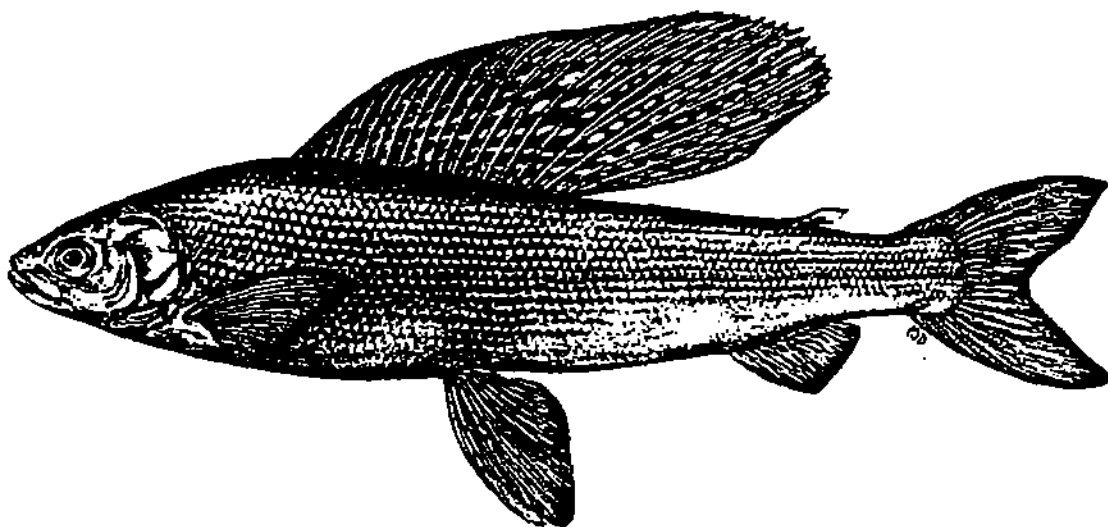

FUNDAMENTALS OF CULVERT DESIGN FOR PASSAGE OF WEAK-SWIMMING FISH

Final Report



Report No. FHWA-AK-RD-90-10



REPORT DOCUMENTATION PAGE

Form Approved
OMB No. 0704-0188

Public reporting burden for this collection of information is estimated to average 1 hour per response, including the time for reviewing instructions, searching existing data sources, gathering and maintaining the data needed, and completing and reviewing the collection of information. Send comments regarding this burden estimate or any other aspect of this collection of information, including suggestions for reducing this burden, to Washington Headquarters Services, Directorate for Information Operations and Reports, 1215 Jefferson Davis Highway, Suite 1204, Arlington, VA 22202-4302, and to the Office of Management and Budget, Paperwork Reduction Project (0704-0188), Washington, DC 20503.

1. AGENCY USE ONLY (Leave blank)		2. REPORT DATE April 1991	3. REPORT TYPE AND DATES COVERED Final	
4. TITLE AND SUBTITLE Fundamentals Of Culvert Design For Passage Of Weak-Swimming Fish			5. FUNDING NUMBERS HR-4000 87-14	
6. AUTHOR(S) Charles E. Behlke, Douglas L. Kane, Robert F McLean, and Michael D. Travis				
7. PERFORMING ORGANIZATION NAME(S) AND ADDRESS(ES) Alaska DOI&EF Statewide Research 2301 Peger Road Fairbanks, AK 99709-6394			8. PERFORMING ORGANIZATION REPORT NUMBER HWA-AK-RD-90-10	
9. SPONSORING/MONITORING AGENCY NAME(S) AND ADDRESS(ES) Alaska DOI&EF Research Section 2301 Peger Road Fairbanks, AK 99709			10. SPONSORING/MONITORING AGENCY REPORT NUMBER HWA-AK-RD-90-10	
11. SUPPLEMENTARY NOTES Conducted in cooperation with the U.S. Department of Transportation, Federal Highway Administration				
12a. DISTRIBUTION/AVAILABILITY STATEMENT			12b. DISTRIBUTION CODE	
13. ABSTRACT (Maximum 200 words) <p>Properly designed culverts do not produce water velocities that exceed fish swimming abilities. Fish have two different musculature systems for swimming. A white muscle system that generates power for short, vigorous swimming. A red muscle system that furnishes power for long, sustained swimming. The culvert design must account for both swimming modes. Therefore, the engineer must know the hydraulic conditions where the fish swims. These conditions change throughout the culvert. The engineer determines acceptable hydraulic conditions for fish by matching known fish swimming power and energy capabilities.</p> <p>Subcritical flow is necessary to pass weak-swimming, upstream-migrating fish. Therefore, this requirement precludes the use of inlet control. The engineer may use artificial roughness to create areas of slower water velocities within culverts. Examples of these are depressed inverts, weir baffles, and deep culvert corrugations.</p> <p>This manual presents design procedures to pass upstream-migrating, weak-swimming fish. The manual also displays criteria for retrofitting existing culverts. This paper does not present cost-effective design criteria for strong-swimming fish.</p>				
14. SUBJECT TERMS Fish passage, highway stream crossing, culvert design			15. NUMBER OF PAGES 177	
			16. PRICE CODE 16.00	
17. SECURITY CLASSIFICATION OF REPORT Unclassified	18. SECURITY CLASSIFICATION OF THIS PAGE Unclassified	19. SECURITY CLASSIFICATION OF ABSTRACT Unclassified	20. LIMITATION	

FUNDAMENTALS OF CULVERT DESIGN FOR PASSAGE OF WEAK-SWIMMING FISH

Final Report

**Charles E. Behlke and Douglas L. Kane
Water Research Center
Institute of Northern Engineering
University of Alaska Fairbanks**

**Robert F. McLean
Alaska Department of Fish and Game
Habitat Division, Fairbanks, Alaska**

and

**Michael D. Travis
Alaska Department of Transportation & Public Facilities
Statewide Research, Fairbanks, Alaska**

February 1991

Prepared for

**State of Alaska
Department of Transportation and Public Facilities
Statewide Research M/S 2554
2301 Peger Road, Fairbanks, AK 99709-5316**

In cooperation with

**U.S. Department of Transportation
Federal Highway Administration**

FHWA-AK-RD-90-10

The contents of this report reflect the views of the authors, who are responsible for the facts and accuracy of the data presented herein. The contents do not necessarily reflect the official views or policies of the Alaska Department of Transportation & Public Facilities, the Alaska Department of Fish and Game, or the Federal Highway Administration. This report does not constitute a standard, specification, or regulation.

Publication Cost: \$16.00

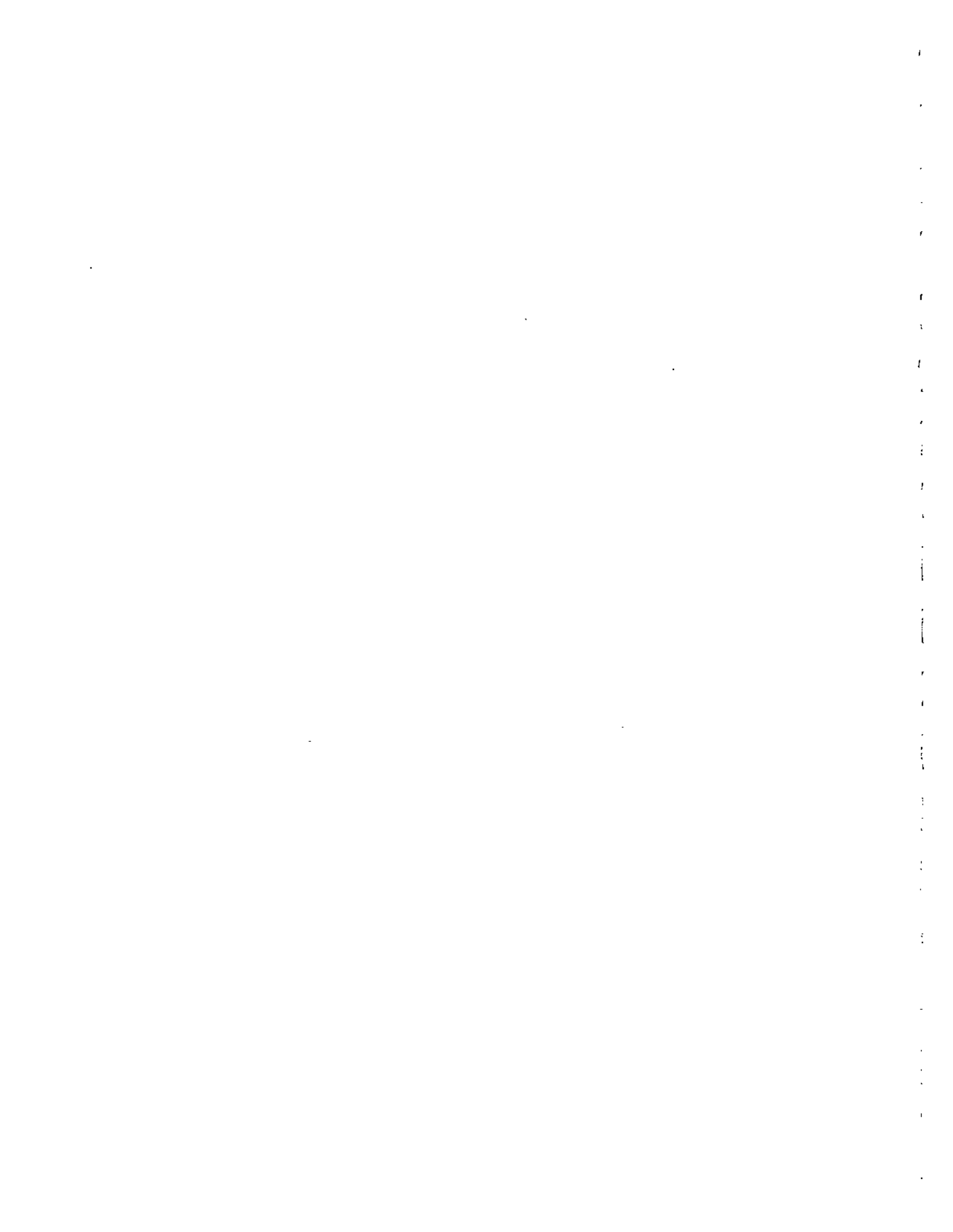

TABLE OF CONTENTS

LIST OF FIGURES	vi
LIST OF TABLES	viii
ABSTRACT	ix
IMPLEMENTATION STATEMENT	x
DEFINITION OF SYMBOLS	xi
I. INTRODUCTION	1
I.A. Background and Purpose	1
I.B. Report Overview	2
II. DESIGN DISCHARGE FOR FISH PASSAGE	4
II.A. Design Floods	4
III. FISH SWIMMING CAPABILITIES	8
III.A. Introduction	8
III.B. Design Fish and Design Discharge	9
III.C. Biological Factors Significant to Fish Passage	9
III.D. Hydraulics of Swimming Fish	11
III.D.1. Profile Drag	11
III.D.2. Gradient Force	13
III.D.3. Virtual Mass Force	16
III.E. Swimming Capabilities of Fish	17
III.F. Energy and Power Produced by Swimming Fish	20
III.G. Scale Effects	24

IV.	CULVERT HYDRAULICS AFFECTING FISH PASSAGE	26
IV.A.	Overview	26
IV.B.	Culvert Outlet	28
IV.B.1.	Critical Depth and Normal Depth	28
IV.B.2.	Outlet Hydraulic Conditions	32
IV.B.3.	Control of Culvert Outlet Tailwater Elevation	36
IV.B.4.	Gabion Weirs	41
IV.B.4.a.	Flat Gabion Weirs	41
IV.B.4.b.	V-Shaped Gabion Weirs	43
IV.B.5.	Submerged Log Weirs	48
IV.C.	Culvert Barrel	49
IV.C.1.	Overview	49
IV.C.2.	Normal and Critical Depths	52
IV.C.3.	Where the Fish Swim	53
IV.C.4.	Culvert Roughness to Control Water Velocities	57
IV.C.4.a.	Corrugation Roughness	57
IV.C.4.b.	Types 1 and 3 Depressed Invert Culverts (DIC's)	58
IV.C.4.c.	Baffled Inverts	59
IV.C.4.c.1.	Introduction	59
IV.C.4.c.2.	Canadian Baffle Systems	60
IV.C.4.c.3.	Summary of the Use of Offset Baffles	70
IV.C.4.d.	Weir-Type Baffles for Steep Culverts	70
IV.C.5.	Settlement of Pool-and-Weir Fishway Culverts	78
IV.C.6.	DOT&PF Rebar Weirs	79

IV.C.7.	Discrete Rip-rap Roughness	82
IV.C.8.	Culvert Bedload Collectors	84
IV.D.	Culvert Inlet	86
IV.D.1.	Inlet Hydraulics	86
IV.D.2.	Hydraulics of Fish at the Culvert Inlet	93
V.	NEW CULVERT DESIGN	98
V.A.	Overview	98
V.B.	Culvert Design	100
V.B.1.	Culvert Barrel Design Requirements for Fish Passage	100
V.B.1.a.	Specific Culvert Barrel Design Steps	102
V.B.2.	Outlet Requirements	106
V.B.2.a.	Design Calculations for Culvert Outlet Zone	111
V.B.3.	Inlet Requirements	118
V.B.3.a.	Design Calculations for Culvert Inlet Zone	120
V.B.4.	Weir-Baffle Design	123
V.B.4.a.	Specific Weir-Baffle Design Steps	126
VI.	RETROFITTING FOR FISH PASSAGE	131
VI.A.	Overview	131
VI.B.	Design of Culvert Retrofits	133
VI.B.1.a.	Specific Retrofit Design Steps	139
VII.	BIBLIOGRAPHY	148
	SUGGESTED ALASKA HYDROLOGY REFERENCES	153
	APPENDIX A	154

LIST OF FIGURES

Figure II-1.	Descriptive hydrograph indicating reduced fish passage design flow (Q_p) resulting from 2-day delay allowance for grayling during spring-runoff flood.	5
Figure III-1.	Profile drag (F_D) acting on swimming fish. This force opposes motion of fish with respect to water.	13
Figure III-2.	Gradient force (F_G) resulting from the vector sum of the fish's buoyant force (B) and its weight (W).	15
Figure III-3.	Virtual mass force resulting from relative acceleration of fish with respect to surrounding water.	16
Figure III-4.	Forces acting on swimming fish. Vector sum of weight (W) and buoyant force (B) is the gradient force (F_G). Fish is moving along a straight streamline.	20
Figure IV-1.	Culvert outlet area.	32
Figure IV-2.	Water surface profiles and depths at culvert outlet as related to tailwater elevation (TW). M profiles occur because $y_n > y_c$	33
Figure IV-3.	Example of gabion weir to create higher tailwater elevation (TW) at culvert than that generated by the stream. More than one such weir in series may be required to achieve appropriate tailwater elevation.	40
Figure IV-4.	View from downstream of flow over right half of V-shaped, gabion, broad-crested weir.	44
Figure IV-5.	Differential element of discharge (dQ) passing over differential width (dx) of gabion weir.	45
Figure IV-6.	One side of V-shaped gabion or large-log weir with vertical side walls at channel edges.	47
Figure IV-7.	Water velocity cross-section (measured by writers) in a 9.5-foot diameter culvert at Fish Creek, Denali Highway, Alaska.	54
Figure IV-8.	Favorable wedge-shaped location at edge of culvert near water surface where corrugation roughness slows water velocities. Sketch is of fish as they have been observed to swim in this location.	55
Figure IV-9.	Definition of terms for depressed invert culverts (DIC's).	58

Figure IV-10.	Definitions of types of depressed invert culverts (DIC's).	59
Figure IV-11.	Canadian offset baffle system for culverts.	61
Figure IV-12.	Streaming and plunging flows in pool-and-weir baffle arrangements for fish passage in culverts.	71
Figure IV-13.	Definition of geometric terms for weir baffles in culvert.	72
Figure IV-14.	(a) Culvert settlement has created excessive drop in water surface elevation between weirs. (b) Intermediate weir added to restore design drop, or less, between pools.	79
Figure IV-15.	Effect of excessive water surface drop between rebar weirs.	81
Figure IV-16.	Rebar and boulder arrangement to reduce water velocities and provide resting locations for fish.	82
Figure IV-17.	Montana bedload connector. "Ladder" is fabricated in 20-foot sections and bolted together when placed in culvert. Cross-members and rebar loops are welded to side members.	84
Figure IV-18.	Details of flow in culvert inlet zone.	87
Figure IV-19.	Conceptual sketch of how culvert skew affects reduced water velocity on one side of the culvert.	92
Figure IV-20.	Observed fish passage routes at difficult inlet.	96
Figure VI-1.	Example of set of $y-Q$ curves for analysis of barrel and outlet.	137
Figure VI-2.	Safe TW elevation when safe fish passage water depth is less than normal depth, and normal depth is greater than critical depth. M-1 water surface profile provides some safety factor.	138

LIST OF TABLES

Table I-1.	Class-I fish. Low-performance swimmers.	1
Table III-1.	Power and energy expenditures computed for grayling ($L_f = 240$ mm) at various locations in culverts studied by writers and for the Hunter and Mayor (1986) analysis of the Jones et al. (1974) data. For the latter a culvert length of 100 ft, $V_{occ} = 2.0$ ft/sec, and $V_f = 0.1$ ft/sec are assumed. Asterisk denotes white muscle mode.	23
Table IV-1.	Discharges and velocities at various critical depths for a range of circular culvert diameters.	31
Table IV-2.	Velocity head in the contracted inlet zone and difference in water surface elevation from the inlet pool to the contracted section.	91
Table A-1.	Fish passage performance design categories for Alaskan fish species.	151
Table A-2.	Swimming performance of Alaskan fish species ($L =$ total length of fish in meters; $t =$ duration of swimming effort in seconds; velocity in meters per second). From Hunter et al.,(1986); original field data source noted.	155

ABSTRACT

Properly designed culverts do not produce water velocities that exceed fish swimming abilities. Fish have two different musculature systems for swimming. A white muscle system generates power for short, vigorous swimming. A red muscle system furnishes power for long, sustained swimming. The culvert design must account for both swimming modes. Therefore, the engineer must know the hydraulic conditions where the fish swims. These conditions change throughout the culvert. The engineer determines acceptable hydraulic conditions for fish by matching known fish swimming power and energy capacities.

Subcritical flow is necessary to pass weak-swimming, upstream-migrating fish. Therefore, this requirement precludes the use of inlet control. The engineer may use artificial roughness to create areas of slower water velocities within culverts. Examples of these are depressed inverts, weir baffles, and deep culvert corrugations.

This manual presents design procedures to pass upstream-migrating, weak-swimming fish. The manual also displays criteria for retrofitting existing culverts. This paper does not present cost-effective design criteria for strong-swimming fish.

IMPLEMENTATION STATEMENT

This manual represents the results of nine years of fish passage research. The Alaska Department of Transportation and Public Facilities (DOT&PF) and the Federal Highway Administration (FHWA) sponsored these studies. The research teams consisted of engineers, hydrologists, and biologists from the University of Alaska Fairbanks, Alaska Department of Fish and Game, and DOT&PF Statewide Research. These multi-disciplined teams worked cooperatively to define cost-effective solutions for passing fish upstream through highway culverts.

In the past, fish passage problems were studied by either engineers or biologists. These disciplines rarely mingled. Thus, communication problems often arose and specific concerns were not met. Engineers concentrated on passing flood flows without subjecting the highway to unreasonable risks. Biologists wanted upstream migrating fish passed through drainage structures during critical times in the fishes' life cycle. These objectives conflicted when the resource agencies recommended installing bridges instead of the cheaper culverts. The cost difference between installing culverts and bridges was substantial. Therefore, the FHWA and DOT&PF decided to commit funds and resources to study the problem. They tasked the research team to develop cost-effective design recommendations that were agreeable between DOT&PF and the resource agencies.

This manual lays out the design assumptions and criteria that is needed to effectively design a culvert for fish passage. The methodology requires close coordination between resource agencies and the developing agency. The developer must agree with the regulatory agencies on the "design fish" and critical passage time before culvert design can begin.

Statewide Research is developing a software package for this manual. The program will assist engineers in selecting design flows, evaluating alternatives, and finalizing design parameters. The project manager estimates that the software will be completed within one month of the manual's publication date. Please contact Billy Connor, Northern Region Hydrologist, for a copy.

Michael D. Travis, P.E., C.E.P.
Project Manager

DEFINITION OF SYMBOLS AND ABBREVIATIONS

A	Cross-sectional area of water flow. Adverse sloping channel water surface profile.
A_c	Cross-sectional area of flow at critical depth.
A_f	Cross-sectional area of flow when fish passage design discharge flows at upper limit of safe, fish passage, mean velocity in a culvert.
A_n	Cross-sectional area of flow at normal depth.
A_o	Cross-sectional area of flow at the culvert outlet lip.
a	Regression constant.
a_f	Acceleration of a fish with respect to a fixed reference.
a_{fw}	Acceleration of a fish with respect to the surrounding water. Vector difference between fish's acceleration and that of the surrounding water.
<i>ave</i>	Average value of the preceding term.
a_w	Acceleration with respect to a fixed reference of the water at a location in the flow where fish swim.
B	Width of water surface across the culvert.
B_c	Width of water surface across the culvert at critical depth.
B_w	Weir crest length across culvert.
b	A constant.
C_c	Hydraulic coefficient of contraction.
C_D	Profile drag coefficient.
C_d	Coefficient of discharge.
cfs	Volumetric flow rater (cubic feet per second).
c_f	Friction coefficient in weir flow.
D	Culvert diameter.

<i>DIC</i>	Depressed invert culvert.
<i>d</i>	Depth of fill in bottom of depressed invert culvert.
<i>dQ</i>	Differential element of discharge from the crest of a weir.
<i>dt</i>	Differential element of time.
<i>d_w</i>	Depth of flow over a weir in streaming flow.
<i>d_x</i>	Differential distance.
<i>E</i>	Net energy delivered by a fish over a specific time period (the integral of <i>P dt</i>).
<i>E_{allowable}</i>	Allowable white muscle energy delivered in a single burst. For a 240-mm grayling, this is taken as 12 joules.
<i>E_{outlet}</i>	Energy that a fish delivers to pass through the first foot of the culvert as it enters the outlet.
<i>F_B</i>	Fish's buoyant force.
<i>F_D</i>	Profile drag force on a fish.
<i>F_{Dc}</i>	Maximum profile drag force that a fish is capable of swimming against in the red muscle mode and in the absence of other inhibiting forces.
<i>F_G</i>	Gradient force on a fish, which is the vector resultant of fish's weight and buoyant force.
<i>F_{vm}</i>	Virtual mass force on a fish due to water acceleration and/or acceleration of the fish.
<i>ft</i>	Unit of measurement, foot.
<i>ft/sec</i>	Feet per second.
<i>g</i>	Acceleration due to gravity.
<i>H</i>	Elevation of water surface of culvert inlet pool with respect to the culvert's inlet invert. Depth of flow at upstream end of a cell between weir baffles. Head on broad-crested weir. Horizontal channel, water surface profile.
<i>HGL</i>	Hydraulic grade line.

H_o	Elevation of upstream water surface with respect to the lowest part of the V in a V-notch gabion weir.
H'	Elevation of upstream water surface with respect to the top of a V-notch gabion weir at the stream bank edges of the weir.
h	Baffle height.
h_L	Head loss.
h_p	Elevation of pool surface just upstream from a weir.
h_w	Elevation of weir pool <i>W.S.</i> above weir crest in plunging flow.
<i>in</i>	Unit of measurement, inch.
K	A coefficient.
K_e	Hydraulic loss coefficient for culvert inlet.
k	A constant.
L	Total length of fish.
L_c	Culvert length.
L_f	Fork length of fish.
L_w	Distance between weir plates in a culvert.
M	Mild sloping channel water surface profile.
m	Rank of a flood in a series of flood values. Unit of measurement, meter.
<i>min</i>	Unit of time measurement, minute.
<i>m/sec</i>	Meters per second.
<i>mm</i>	Unit of measurement, millimeter.
N	Total number of years of hydrologic data. Newtons. Number of weir baffles in a culvert.
N_R	Reynolds number of a swimming fish $\left[V_{fw} \frac{L}{\nu} \right]$.

n	Manning roughness coefficient.
n_b	Manning roughness coefficient for invert bed-material of depressed invert culvert.
n_s	Manning roughness coefficient for culvert walls.
P	Net power delivery by a swimming fish.
$P_{300\text{ mm}}$	Power a 300 mm fish must deliver.
$P_{240\text{ mm}}$	Power a 240 mm fish must deliver.
P_c	Net power that a fish is capable of delivering for a given period t .
$P_{ave-1'}$	Net power delivery in the white muscle mode by fish swimming 1 foot upstream from culvert outlet lip.
P_{cr}	Net power that a fish is capable of delivering while swimming in the red muscle mode.
P_{cw}	Net power that a fish is capable of delivering while swimming in the white muscle mode.
P_{inlet}	Net power delivery of fish while swimming through inlet zone of culvert.
P_{outlet}	Net power delivery of fish while swimming through outlet zone of culvert.
$P_{required}$	Net power delivery required for a fish to swim through a culvert segment.
P_{us}	Net white muscle power delivery required of a fish as it approaches the upstream end of the culvert outlet zone.
P_{weir}	Power delivery necessary for a fish to pass over a weir baffle. This is usually white muscle power.
p	Wetted perimeter of flow in culvert or channel. Mean annual precipitation.
p_b	Channel width across horizontal invert of depressed invert culverts.
p_s	Total wetted perimeter of both sides of a corrugated culvert, from water surface down to invert. If the culvert does not have a depressed invert, this is the entire wetted perimeter of the culvert.
p_w	Height of weir crest above culvert invert.

Q	Volumetric water flow rate (discharge), ft^3/sec or m^3/sec .
Q_2 or $Q_{2.33}$	Mean annual flood flow rate, depending on statistical method adopted.
$Q_{2.33-2 \text{ day}}$	Mean annual flood flow rate with two day delay peak reduction.
Q_5	Flood flow rate with 5-year return period.
Q_{50}	Flood flow rate with 50-year return period.
Q_{100}	Flood flow rate with 100-year return period.
Q_f	Maximum design flow rate for fish passage.
Q_m	Peak value of a flood of return period m .
$Q_{m,s}$	Peak value of a seasonal flood of return period m .
$Q_{m-2 \text{ day}}$	Flood discharge with a return period of m and 2-day duration.
$Q_{MA,S}$	Mean-annual seasonal flood.
Q_c	Dimensionless discharge for flow through Canadian offset baffles or for flow over weir baffles.
R	Hydraulic radius $\left[\frac{A}{P} \right]$.
R_n	Hydraulic radius at normal depth.
S	Season of the year. Surface area of a fish. Steep water surface profile.
S_e	Slope of energy gradient.
S_o	Slope of culvert invert.
SSP	Structural steel plate.
s	Distance.
sec	Unit of time measurement, second.
T	Propulsive thrust of a swimming fish.
TW	Elevation of outlet pool water surface with respect to culvert outlet invert elevation.

t	Time period.
U	Maximum flow velocity through offset baffle slots. Maximum water velocity over weir baffle.
U_c	Dimensionless velocity of flow for offset baffles or for weir baffles.
u	Velocity of flow at a vertical location, y , above the channel invert for offset baffle flow. Velocity of flow at a vertical location, y , above a weir baffle at the center of the weir baffle.
V_{ave}	Average water velocity in cross section of flow, $\frac{Q}{A}$.
$V_{ave-outlet}$	Average cross-section water velocity at the outlet lip.
$V_{ave-1'}$	Average cross-section water velocity 1' U.S. from the outlet lip.
V_{avef}	V_{ave} at fish passage design flow.
V_B	V_{ave} in the culvert barrel downstream from inlet zone.
V_c	Hydraulic critical velocity of flow.
V_{ctr}	Water velocity at centerline of culvert at inlet contraction.
V_{cr}	Water velocity on a weir crest.
V_f	Velocity of a fish with respect to fixed reference.
V_{fw}	Velocity of a fish with respect to the surrounding water.
V_{frc}	Maximum velocity, with respect to the surrounding water, that a fish is capable of swimming against while utilizing the red muscle mode for a given time period, t .
V_n	Average cross-sectional water velocity at normal depth.
V_{occ}	Water velocity where fish swim, usually near a boundary.
V_{pool}	Water velocity of approach in inlet pool.
V_w	Velocity of water with respect to fixed reference.
Vol	Fish's volume.

W	Fish's weight.
$W.S.$	Water surface.
x	A location with respect to a fixed origin.
Y_o	A reference depth with respect to the invert. Depth of flow halfway between adjacent weirs.
Y_B	A reference depth in oblique slot between two dissimilar, offset baffles.
Y_o	Water depth with respect to invert at culvert outlet.
Y_p	Depth of flow with respect to culvert invert immediately upstream from a weir baffle.
y	Depth of flow measured normal to culvert or channel invert.
y_{avg}	Depth of flow necessary for safe mean water velocity for fish in a culvert at a specific Q .
y_c	Critical depth of flow. Occurs where $\frac{Q^2 B}{g A^3} = 1.0$.
y_n	Normal depth of flow. Depth of flow where $Q = A R^{4/3} S_o^{1/2}$.
y_1	Depth of flow 1' U.S. from the culvert outlet lip.
z	Elevation above a fixed reference.
γ	Specific weight of water surrounding fish, lb/ft ³ .
ΔH	Drop in water surface from inlet pool to contracted inlet section.
Δs	A distance.
Δs_{outlet}	Length of the outlet zone.
Δt	Time period.
ΔV	Velocity difference over distance Δs .
Δy	Change in water-depth over distance Δs .

- θ Angle that the hydraulic grade line slopes with respect to the horizontal.
- θ_o Angle that the culvert invert slopes with respect to the horizontal.
- ν Kinematic viscosity of water through which fish swim.
- ρ Mass density of water through which fish swim.
- ϕ Approaching a fish, angle that the water velocity slopes with respect to the horizontal.
- ∇ Differential operator $\left[\frac{\partial}{\partial x} \right] i + \left[\frac{\partial}{\partial y} \right] j$, where i and j are unit vectors in the x and y directions.
- ∇p Gradient of the pressure.

I. INTRODUCTION

I.A. Background and Purpose

This document presents the fundamental fluid mechanic and biological aspects of fish passage through culverts and relates them to passage of *weak-swimming*, Class-I fish through culverts (Table I-1). Because the writers have made rather detailed studies of only Arctic grayling (*Thymallus arcticus*), their design recommendations should be used only for Class-I fish.

These recommendations must *not* be considered for the cost-effective design of culverts for the passage of salmon or other strong swimming fish. However, this report's fundamental biological and fluid mechanics concepts of swimming fish apply to moderate- and high-performance swimming fishes, including salmon.

TABLE I-1. Class-I fish. Low-performance swimmers.

Arctic Grayling
Long Nose Sucker
Northern Pike
Stickleback
Whitefish
Burbot
Sheefish
Smelt
Sculpin
Dolly Varden/Arctic Char
Upstream migrant salmon fry

The successful passage of fish through highway culverts depends on hydraulic conditions at the culvert outlet, in the barrel, and at the inlet. Normally, culvert design consists of selecting a culvert which successfully passes a flood of given magnitude without producing undesirable consequences upstream, downstream, and to the roadway. This document attempts to acquaint the design engineer with the micro-hydraulic details of a culvert's inlet, outlet, and barrel relevant to fish passage. In addition to hydraulic conditions in the culvert itself, those of the outlet pool take on special significance for the passage of weak-swimming fish.

The writers have studied the hydraulic details of culvert flow and fish swimming location preferences at two culverts (Behlke et al., 1988; Behlke et al., 1989; Kane et al., 1989; Behlke, 1987; Behlke, 1988; Behlke, 1991). The results of the studies are used in this report. Katopodis et al. (1978) have also studied the details of flow in three 14-ft culverts in Canada, but fish were unable to enter those three culverts during the study. Therefore, they did not identify fish swimming locations. They did, however, obtain excellent, detailed hydraulic data within the culverts, and that information is used here.

I.B. Report Overview

The determination of design flood magnitudes for various return periods is discussed in other printed publications well known to design engineers, and it is not repeated here. This report briefly addresses a determination of the design flow of spring-runoff floods as it relates to fish passage (Chapter II). It subsequently presents a summary of fish swimming capabilities (Chapter III) and the important hydraulic details of culvert flow (Chapter IV). It then brings these topics together by discussing the interaction between swimming fish and culvert hydraulics (Chapter IV). The report describes how this information is used for designing new culverts for fish passage (Chapter V) and for retrofitting existing culverts (Chapter VI). The accompanying complete program, requires the design engineer to input fundamental culvert and fish information and then perform necessary calculations to determine suitability of specific designs. The software relies on the design engineer to determine the general design. Since the fish's swimming capabilities are built into the software, the design engineer may not overstep the boundaries of those capabilities. The software allows the engineer to quickly investigate alternative design possibilities.

Throughout this report the writers have introduced assumptions regarding the behavior of fish. The writers based these assumptions on extensive field observations of hundreds of Arctic grayling (*Thymallus arcticus*) at only two fish passage culverts. Since these field studies extended over the spring-runoff periods at both culverts, stream discharges varied considerably. This changed culvert flow conditions during the fish runs. The hydraulic details and the swimming details of hundreds of fish were studied as the fish negotiated or failed to negotiate these culverts. Some experienced readers may feel more comfortable with other assumptions regarding some of the constants. However, the writers attempt to explain carefully the various computational elements of this report. Therefore, readers who are not comfortable with the writers' assumptions can use their own, while using the report's methodology to arrive at suitable designs.

The interaction of swimming fish with culvert hydraulics is discussed beginning at the outlet and proceeding upstream (Chapter IV). The writers selected this order because it is the sequence in which fish pass through the culvert, and it is the sequence of hydraulic cause and effect for fish passage culverts.



II. DESIGN DISCHARGE FOR FISH PASSAGE

Chapter Summary:

This chapter summarizes Alaskan hydrology literature relating to fish passage. The design discharges for fish passage culverts are defined. How a short delay of a spawning run affects the design flow for fish passage (Q_f) is shown. The procedure for defining Q_f is developed.

II.A. Design Floods

Culvert design for fish passage requires that two flows be determined: (1) the instantaneous maximum flood that the culvert must safely pass (usually Q_{50}) and (2) peak discharge for fish (Q_f). The instantaneous maximum flood that the culvert must pass is usually several times greater than Q_f . To arrive at an appropriate value for Q_f , a hydrologic flood frequency analysis must be made to determine magnitude of the mean-annual flood occurrence during the expected time duration of the fish run. This may or may not coincide with the usual timing of the mean-annual flood (Q_2 or $Q_{2.33}$, depending on the frequency distribution used). During the annual Arctic grayling spawning migration, the Alaska Department of Fish and Game (ADF&G) accepts the mean-annual spring-runoff flood as a beginning point in determining Q_f . This flood discharge is used because the grayling spawning run occurs during that period. This flow can be further reduced somewhat because grayling can be delayed for up to 2 days without serious spawning consequences (Fleming,

1989). Thus, for grayling, the design-flood flow for fish passage (Q_f) is the 2-day duration discharge of the mean-annual spring-runoff flood. Since the spring-runoff flood usually extends for several days, even on relatively small streams, Q_f may not be a great deal less than the magnitude of the mean-annual spring-runoff flood (Figure II-1).

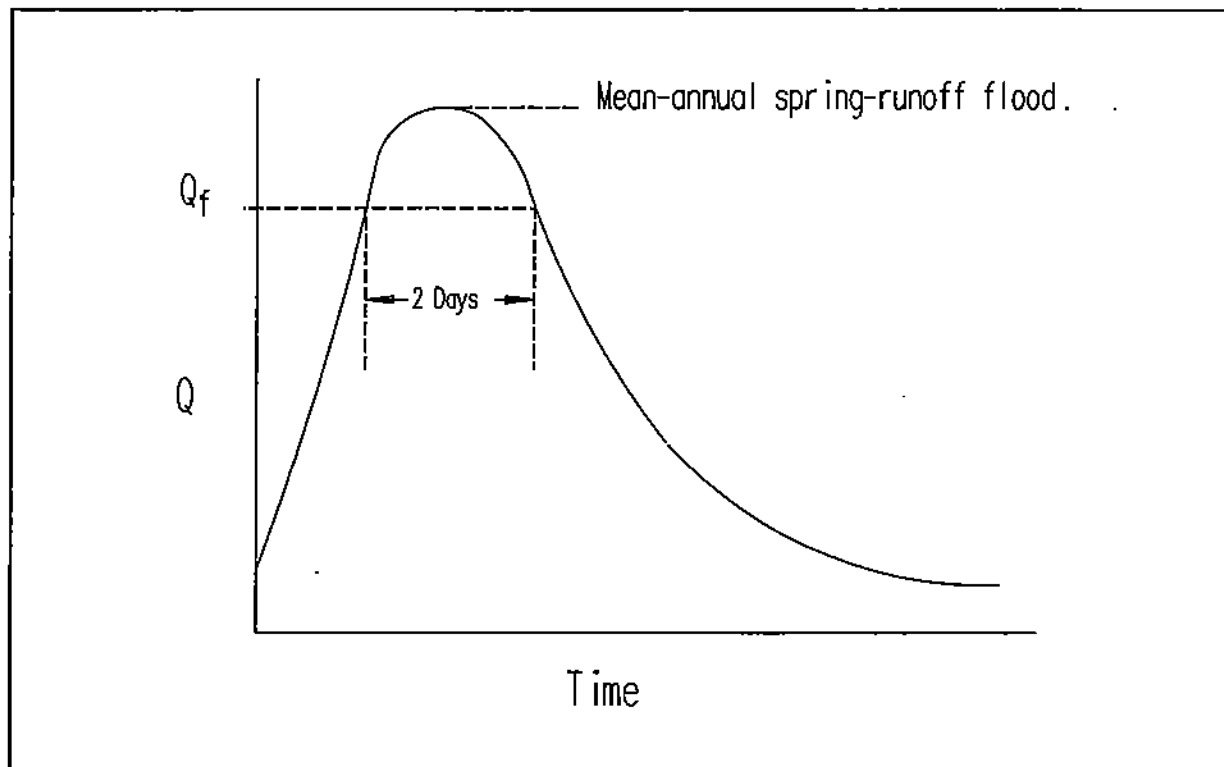

Figure II-1. Descriptive hydrograph indicating reduced fish passage design flow (Q_f) resulting from 2-day delay allowance for grayling during spring-runoff flood.

Juvenile fish do not have such critical migration time periods as grayling do to pass through a highway culvert. Therefore, juveniles can be held downstream of a culvert longer.

However, Tilsworth and Travis (1989) noted that fish become vulnerable to sport fishing when pooled in a culvert outlet pool. Therefore, the writers discourage long delay periods for fish passage flows.

Several documents that cover the appropriate methodology for Alaska flood frequency analysis are listed separately in the Bibliography. However, the following additional discussion for the determination of the Q_f may be helpful.

In reality, the mean-annual seasonal flood ($Q_{MA,S}$) is seldom observed in the field. However, that value can be calculated from flood frequency analysis. Then, known flood hydrographs which have peaks close to that value can be selected for further analysis. For example, if $Q_{m,S} = 125$ cfs (m is the return period and S is the season of the year—spring, summer, fall, or winter), the 2-day duration flow for the 125 cfs flood can be determined (Figure II-1).

This results in a flood of magnitude $Q_{m-2 \text{ day}}$. Linearity between floods of approximately the same magnitude is reasonable to assume. Thus,

$$Q_f = Q_{m-2 \text{ day}} \left[\frac{Q_{MA,S}}{Q_{m,S}} \right]. \quad \text{-----Eq. 2.1}$$

For analyses of this type the writers suggested that a few hydrographs with peaks close to $Q_{MA,S}$ be examined and an average value be calculated for the final design fish passage flow (Q_f).

For passage of fish species other than grayling, the hydrologic study must recognize the mean-annual flood of the season in which the stream's fish run(s) occur. The resource agency must give the allowable delay for these species.

If the resource agency determines that a fish population can withstand a delay greater than 2 days in their upstream migration without harmful effects, the fish passage design flow may be reduced more than it would be for grayling. The percentage of flow reduction for any given acceptable delay period is not a constant for all drainage basins, but depends on the shape of the hydrograph at each site.

Because of the limited duration of stream flow records in Alaska, flood estimates for long return periods are made with less confidence than for shorter return periods. Thus, estimates of the Q_{50} or Q_{100} could be relatively poor, while estimates of the mean-annual flood for each season of the year in which fish passage is required may be rather accurate.

Unfortunately, there are situations where flood frequency estimates must be made, regardless of the status of available data.

The probability is relatively small that upstream-migrating fish will arrive at a culvert during the occurrence of a major flood (Arctic Hydrologic Consultants, 1985). Thus, there is justification for using a Q_r of short return period. Now, Q_r for culverts supporting runs of *Class-I fish* is based on the appropriate seasonal, mean-annual flood modified for a 2-day duration period. For grayling, spring is the selected season that corresponds to expected fish runs.

III. FISH SWIMMING CAPABILITIES

Chapter Summary:

This chapter is an overview of biological and fluid mechanic parameters that fish encounter as they pass through culverts. The writers present specific constants and several observations resulting from field studies that apply only to grayling. Red muscle and white muscle capabilities are defined, and locations where each of these is important to passage through culverts are discussed. Fluid mechanic forces acting on fish swimming in culverts are defined and described in equation form. Fish energy and power output requirements are also developed and presented in equation form.

III.A. Introduction

Culvert flow varies with time in response to stream hydrology. If the flow through a culvert temporarily prohibits passage of fish moving upstream, the fish can wait for more favorable flow conditions. However, during the time of the annual spawning run of some species it is necessary that their movement upstream to preferred spawning sites not be delayed too long (Fleming, 1989). Thus, it is important that culvert design allows passage (with no more than an acceptable delay period) for a large percentage of those fish that are expected to spawn. The resource agency must select a generic design flow for fish passage (Q_2 , Q_5 , etc.) which ensures that an acceptable percentage of spawning fish pass through the culvert.

The resource agency must also identify the design fish species and fork length, allowable delay period, and the timing of the fish migration. The design agency calculates the stream flow value that represents the design stream flow for fish passage (Q_f) of the culvert design.

III.B. Design Fish and Design Discharge

In Alaska, the ADF&G selected the 240-mm fork length (L_f) grayling as representative of *Group I low-performance juvenile and adult fish*. This is the design fish used for most examples in this report. In 1990, the mean-annual flood with a 2-day delay ($Q_{2.33-2 \text{ day}}$) has been selected for the maximum flow that must allow upstream passage of at least 75% of fish having the swimming capabilities of the design fish.

III.C. Biological Factors Significant to Fish Passage

For a detailed description of biological aspects of the swimming capabilities of fish, see Webb (1975). The brief discussion that follows summarizes some of the elements described in that publication. The writers suggest these elements are of prime importance for design engineers to better understand the options available for proper design of fish passage culverts.

Fish propulsion results from the swimming musculature activities of red and white muscle systems. As with humans, fish use the red muscle system for longer-term activities and functions in an aerobic state. They use this muscle system for slow, continuous swimming. The maximum generation of red muscle power over time is a slowly decaying function.

White muscle activity is anaerobic in nature and provides elevated levels of swimming power for short periods. It is a rapidly decaying function over time. Severe white muscle swimming activity quickly leaves the fish in a state of white muscle exhaustion. White muscle swimming activity cannot resume until after the fish has experienced a rest period (Blaxter, 1969).

Visual observations of swimming fish gives a good indication of which muscle system is being used at any time. Fish swimming in a lazy fashion with relatively large-amplitude, low-frequency caudal (tail) fin motions use their red muscle systems for propulsion. On the other hand, fish swimming with high-frequency, small-amplitude caudal fin motions use their white muscle systems for propulsion. Fish use this mode of swimming to escape predators, to feed, or to swim past severe hydraulic obstacles of limited extent. Entrance into a difficult culvert outlet condition is an appropriate example of the use of a fish's white muscle system. The sustained type of swimming required for a fish to swim through the barrel of a culvert is an example of swimming in the red muscle mode. Fish subjected to difficult conditions at a culvert outlet may not be able to swim out of a difficult culvert inlet. They may require considerable rest to replenish their white muscle reserves. The writers have observed grayling, apparently exhausted in the white muscle mode from entering a difficult culvert outlet, progress upstream to the inlet. The inlet zone presented difficult swimming conditions. The grayling then washed downstream and out of the culvert.

The writers observed fish swimming with much different muscle motion when severely stressed than when they are clearly moving in the red muscle mode. The writers assume, for computational purposes, that fish swim in either the red or white muscle mode, but do not

mix the two. This appears to be a reasonable assumption, though probably not strictly true, since visual observations reveal an abrupt change in body motion when fish move from a zone of difficulty to one of relative ease. Thus, for example, in a difficult culvert outlet situation, the writers assume that all the necessary power is white muscle generated power. Conversely, in a satisfactorily designed culvert barrel, they assume all the power delivered is red muscle generated.

The fact that fish can expend swimming energy at certain maximum rates does not mean that they choose to do so when confronted with specific obstacles. Behlke (1987, 1991) speculates that fish swimming in culvert barrels of unknown extent attempt to *minimize* power output consistent with moving slowly ahead in the culvert, though they may be physically capable of moving ahead faster.

III.D. Hydraulics of Swimming Fish

III.D.1. Profile Drag

Elementary fluid mechanics texts usually characterize fluid drag on a given object by presentation of a plot of drag coefficient (C_D) versus a representative Reynolds number (N_R).

The drag which C_D relates to is called profile drag. It includes skin friction and pressure forms of drag. The data which makes such a plot possible is usually obtained by suspending a scale model of the object in a wind or water tunnel while measuring the drag force exerted by the moving fluid on the body. A support holds the body in a rigid state in the tunnel and is used in measuring the drag force.

Since fish carry their propulsion systems with them, the profile drag on fish cannot be measured by the same methods as those outlined above for bodies which rely on an outside source for support in the moving fluid. No experiment has been devised which makes it possible to directly measure profile drag on fish.

Recognizing the present impossibility of directly measuring profile drag on swimming fish, interested biologists and applied mathematicians have attempted to define profile drag on fish by analytical methods (Lighthill, 1971; Webb, 1971; Webb, 1975; Blake, 1983). For conditions where the fish swims with a turbulent boundary layer, profile drag can be expressed as

$$F_D = \frac{C_D \rho S V_{fw}^2}{2}, \quad \text{-----Eq. 3.1}$$

where C_D is a profile drag coefficient in the usual engineering sense, ρ is the mass density of water, S is the surface area (not cross-sectional area) of the fish, and V_{fw} is the swimming velocity of the fish with respect to the surrounding water. C_D for the turbulent boundary around the fish is given by (Webb, 1975):

$$C_D = k(0.072) N_R^{-0.2}, \quad \text{-----Eq. 3.2}$$

where k is a constant which appears to vary from 3 to 5, depending on the fish and the particular swimming conditions, N_R is the Reynolds number of the swimming fish (which is defined as $N_R = V_{fw} L/\nu$, where L is the *total* length of the fish), and ν is the kinematic viscosity of the surrounding water. The surface area of a fish can be expressed as $S = bL^2$,

where b is a constant depending on the individual fish. The value of b is usually close to 0.4, which is the value adopted here for later computations. Thus, Equation 3.2 can be expressed as

$$F_D = \frac{b k (0.072) (\rho) (v)^{0.2} L^{1.8} V_{fw}^{1.8}}{2} \quad \text{-----Eq. 3.3}$$

For $b = 0.4$ and $k = 4$,

$$F_D = 0.0576 (\rho) (v)^{0.2} L^{1.8} V_{fw}^{1.8} \quad \text{-----Eq. 3.4}$$

In the vector sense, F_D is always directly opposed to the fish's motion with respect to the water (Figure III-1).

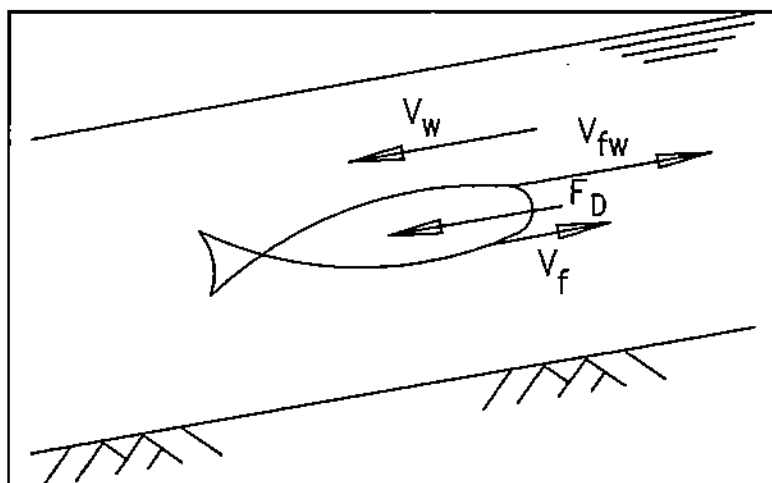

Figure III-1. Profile drag (F_D) acting on swimming fish. This force opposes motion of fish with respect to water.

III.D.2. Gradient Force

The gradient force (F_G) acting on the fish is defined as the vector resultant of the fish's weight and its buoyant force. A

fish's weight is a body force which is always directed vertically downward, regardless of the fish's motion or hydraulic conditions surrounding it. Behlke (1987) has shown that the fish's buoyant force depends on the pressure gradient of the water surrounding the fish. In a lake the pressure distribution is hydrostatic. If the specific weight of the fish is the same as that of the surrounding water, the fish's buoyant force is equal and opposite to its weight, so buoyant and weight forces cancel. Since F_G is the vector sum of the weight and buoyant

forces, it is zero for a neutrally buoyant fish swimming in water where the hydraulic grade line (HGL) has zero slope (i.e., no water velocity). In such a situation, the HGL is horizontal and lies on the water surface. (Note: Unless otherwise specified, this report assumes the HGL to be coincident with the water surface.)

In open channels or pipes when water moves, friction losses result in the HGL's sloping downward in the direction of flow. Here, too, the pressure gradient vector is normal to the HGL. The fish's buoyant force is

$$F_B = -\nabla p \text{ Vol}, \quad \text{-----Eq. 3.5}$$

where ∇p is the pressure gradient vector in the water, and Vol is the fish's volume. F_B is not directed vertically upward. In flowing open channels the fish's weight component, normal to the HGL, is canceled by its buoyant force. However, the component of the fish's weight parallel to the HGL is not canceled and remains as a body force directed downstream parallel to the HGL. This is the gradient force. It opposes the upstream motion of the fish, except where the pressure gradient vector is directed downstream as through a hydraulic jump.

In closed pipes, the fish's weight is completely canceled by the vertical component of its buoyant force. However, its buoyant force also contains a downstream component which has the same effect as the downstream component of the fish's weight in open channels. Behlke (1987) has shown that the magnitude of the gradient force (Figure III-2) for fish swimming in closed pipes is given by:

$$F_G = W (\text{Sin } \phi + \text{cos } \phi (\tan (\theta - \phi))), \quad \text{-----Eq. 3.6}$$

where W is the fish's weight, θ is the angle at which the HGL slopes, and ϕ is the angle at which the HGL slopes, and ϕ is the angle at which the water velocity vector slopes. Both slopes are measured with respect to the horizontal. However, Equation 3.6 is also valid in open channel flow if ϕ is the angle, with respect to the horizontal, of a streamline along which a fish swims, and θ is the angle at which the HGL slopes. In the barrel of a culvert which supports

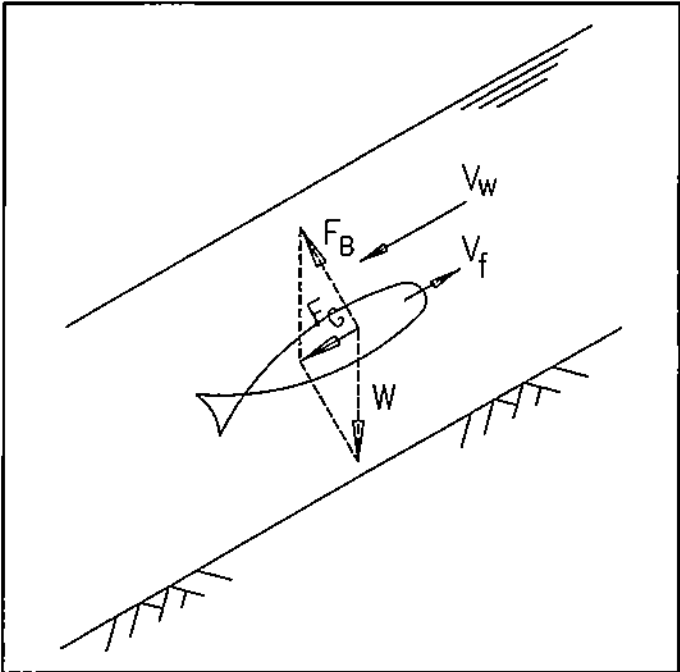

Figure III-2. Gradient force (F_G) resulting from the vector sum of the fish's buoyant force (F_B) and its weight (W).

essentially uniform flow, $\phi = \theta =$

$\tan^{-1} S_o$, where S_o is the slope of the culvert. Thus,

$$F_G = W \left(\sin \left(\tan^{-1} S_o \right) \right). \quad \text{-----Eq. 3.7}$$

For angles less than approximately 6° , $\sin \approx \text{tangent}$, so if $S_o < 6\%$, which is generally the case, Equation 3.7 can be reduced to:

$$F_G = W S_o. \quad \text{-----Eq. 3.8}$$

The writers' field studies (Behlke et al., 1988) found that for grayling the approximate relationship for weight was $W = 0.009 \gamma L_f^3$, where L_f is the fork length of the fish, and γ is the specific weight of water (assumed to be the same as the specific weight of the fish).

Using a fork-to-total-length conversion of 1/0.92, this relationship may be expressed as a

function of total fish length by $W = 0.007 \gamma L^3$. However, expressing F_G in terms of fork length,

$$F_G = 0.009 \gamma L_f^3 S_o, \text{ and} \quad \text{-----Eq. 3.9a}$$

$$F_G = 0.007 \gamma L^3 S_o. \quad \text{-----Eq. 3.9b}$$

III.D.3. Virtual Mass Force

It is necessary for a fish to generate an additional force if it accelerates with respect to the surrounding water as indicated in Figure III-3. This additional force, called the virtual mass force (F_{vm}), is the “ $F = Ma$ ” of immersed objects.

This force is directed opposite to the direction of the fish’s relative

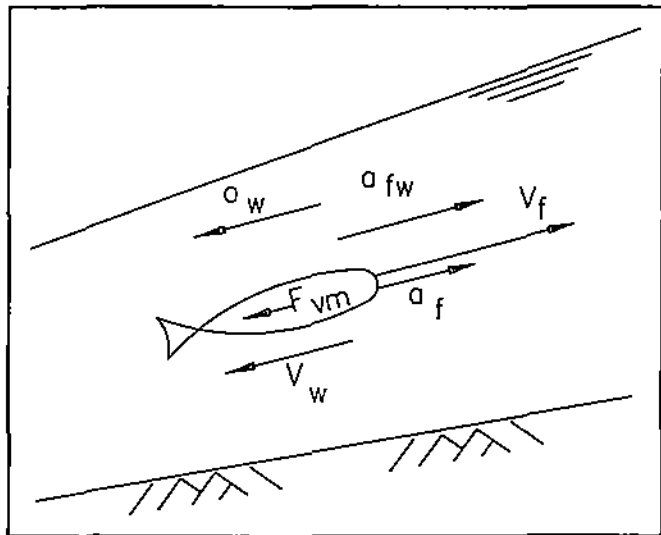

Figure III-3. Virtual mass force resulting from relative acceleration of fish with respect to surrounding water.

acceleration, and it exists regardless of the cause of the relative acceleration. Thus, the force exists if: (1) the fish moves with constant absolute velocity and the surrounding water is accelerating, (2) if the surrounding water moves with constant velocity and the fish accelerates with respect to a fixed reference system, or (3) if both water and fish accelerate with respect to a fixed reference system. This force is expressed as:

$$F_{vm} = 1.2 \left[\frac{W}{g} \right] a_{fv}, \quad \text{-----Eq. 3.10}$$

where a_{fw} is the relative acceleration of the fish with respect to the surrounding water. The constant 1.2 results from the fact that some of the water in the boundary layer surrounding the fish moves with and accelerates with the fish (Webb, 1975).

In analyzing accelerating flow zones associated with culverts, it is usually assumed that the fish has a constant velocity with respect to a fixed reference system (V_f), and a_{fw} is given by:

$$a_{fw} = \frac{(V_{fw})_{ave} \Delta V_{fw}}{\Delta S}, \quad \text{-----Eq. 3.11}$$

where ΔV_{fw} is the change in V_{fw} over a distance ΔS , and $(V_{fw})_{ave}$ is the average value of V_{fw} over the same distance.

III.E. Swimming Capabilities of Fish

Controlled tests of swimming performance of fish are difficult and quite expensive to perform. Thus, few have been made which have universal importance to designers. Though salmon have been studied extensively, Arctic grayling (*Thymallus arcticus*) have been the focus only of the writers and of a few other researchers (Jones et al., 1974; McPhee and Watts, 1976; Fisher and Tack, 1977).

The writers measured water velocities flowing under existing, non-controllable local conditions in culverts during the grayling's annual spawning migrations. Jones et al. (1974) performed their tests under controlled conditions but with fish which were not influenced by

the spawning migration stimulus. They used electrical stimulation to force their study fish to swim. They tested fish for 10-min intervals at incrementally increasing water velocities until the fish were exhausted. They selected the 10-min time increment because they believed fish would negotiate a 100-meter (328-ft) culvert in 10 min. However, those authors' experiments had not utilized culverts.

The writers' experiences, and that of others, lead them to believe grayling of 240-mm fork length would require a great deal more than 10 min to negotiate such culverts. For example, Tilsworth and Travis (1986) reported grayling swimming for 40 min through a 110-ft long culvert. Although the swimming performance of grayling swimming for 60 min would be less than for a 10-min time period, it probably would not be greatly less. That is because for either time duration the fish must swim principally in the red muscle mode.

Hunter and Mayor (1986) made an intensive statistical analysis of data published by many researchers. For grayling, they principally relied on the data of Jones et al. (1974). From that data, they statistically developed endurance equations for grayling swimming under the influence of profile drag alone. Their statistically derived formula for *red muscle* swimming performance of grayling (*Thymallus arcticus*) is:

$$V_{fw} = 1.67 L^{0.193} t^{-0.1}, \quad \text{-----Eq. 3.12a}$$

where V_{fw} is expressed in meters/second, L is the *total length* of the fish (meters), and t is time (seconds). It is important to understand that V_{fw} in Equation 3.12a, and in Equations 3.12b, 3.13a and 3.13b which follow, is *constant* over the time period t . In foot-second units, Equation 3.12a is:

$$V_{fw} = 4.38 L^{0.193} t^{-0.1}, \quad \text{-----Eq. 3.12b}$$

where V_{fw} is in ft/sec and L is in feet.

For pink salmon (*Oncorhynchus gorbuscha*) at 20°C, the same authors show the following relationship:

$$V_{fw} = 4.08 L^{0.55} t^{-0.08} \quad (m/sec), \quad \text{-----Eq. 3.13a}$$

$$V_{fw} = 6.98 L^{0.55} t^{-0.08} \quad (ft/sec). \quad \text{-----Eq. 3.13b}$$

Equations 3.12 and 3.13 apply only to red muscle propulsion and have no meaning if t is less than 10 sec.

Fish swimming capabilities have generally been characterized by the terms “burst speed,” “darting speed,” “prolonged speed,” and “sustained speed” (Bell, 1985; Orsborn and Powers, 1985). *Burst speed* and *darting speed* relate principally to white muscle activity. *Sustained* and *prolonged speeds* relate principally to red muscle activity. These terms provide a basis for design decisions if the only net force acting on fish swimming in the design situation is profile drag. However, culvert inlets and outlets usually induce additional gradient and virtual mass forces on swimming fish, and even uniform flow in a steeply sloping culvert barrel may induce gradient forces. Thus, despite popular usage, the terms “burst speed,” “darting speed,” “prolonged speed,” and “sustained speed” have limited meaning in relation to fish passage structures, such as culverts, where rapidly varying flow and sloping hydraulic grade lines occur.

III.F. Energy and Power Produced by Swimming Fish

Ziemer and Behlke (1966) recognized that fish swimming in other than lake conditions encountered gradient force in addition to profile drag. Based on their analytical observations and those by Behlke (1987), the writers have attempted in their studies to include the effects of gradient and virtual mass forces for fish swimming through culverts (Behlke, et al., 1988, 1989).

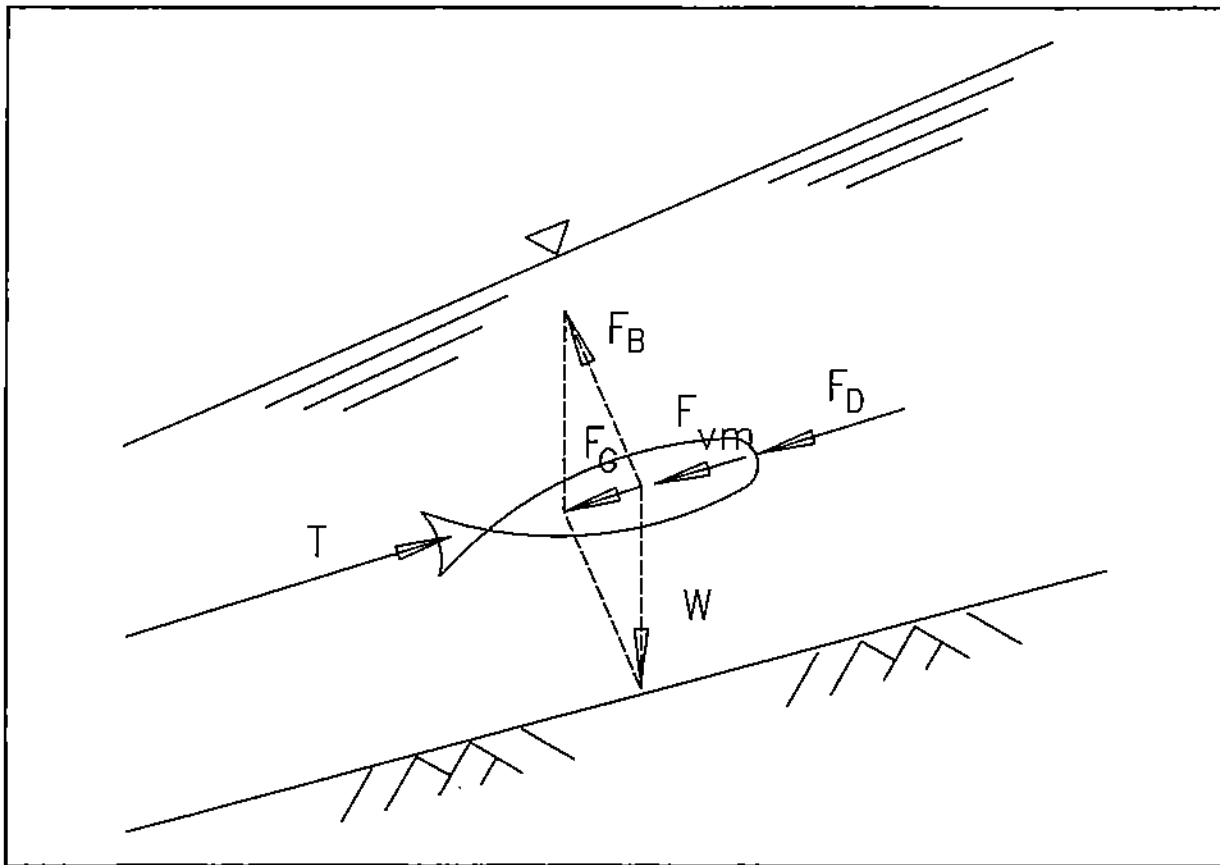

Figure III-4. Forces acting on swimming fish. Vector sum of weight (W) and buoyant force (F_B) is the gradient force (F_G). Fish is moving along a straight streamline.

To predict swimming performance from data which recognizes only profile drag for fish passing through structures where gradient and virtual mass forces also exist, it is necessary to utilize the concepts of power and energy as common denominator parameters. Central to the

development of power and energy production values for swimming fish is the realization that fish must develop their own thrust force (T). This is principally achieved by an interaction between their caudal fin and the surrounding moving water. The resulting T , P , and E are analogous to those of a person *ascending* a *downward*-moving escalator. Power and energy must be expended just to stand still in relation to a fixed reference system. Thus, the net power which a fish expends while swimming is the product of the total drag force, $F_D + F_G + F_{vm}$ (Figure III-4), and the velocity of the fish with respect to the surrounding water (V_{fw}). Thus:

$$P = T V_{fw}, \quad \text{-----Eq. 3.14}$$

$$P = (F_D + F_G + F_{vm})(V_{fw}), \quad \text{-----Eq. 3.15}$$

where P is the instantaneous net power to provide the fish's swimming thrust (T). Equation 3.15 assumes that the forces of that equation and V_{fw} are all collinear vector quantities, which is not always the case. However, this simplification appears to describe most situations of practical importance.

Energy (E) expended by a fish moving through an element of a passage structure is:

$$E = \int P dt, \quad \text{-----Eq. 3.16}$$

where the integration occurs over the time required to pass through the element of the structure. Typically, one integration is required for entrance into the culvert outlet, another for passage through the barrel, and another for exit through the culvert inlet. For

computational purposes, the sum of the drag forces and V_{fw} is assumed constant in the element, so P is also constant. Equation 3.16 can then be expressed as:

$$E = P (\Delta t), \quad \text{-----Eq. 3.17}$$

where Δt is the time required for the fish to move through the specific element of the culvert.

Equations 3.16 and 3.17 can only be evaluated if the velocity of the water (V_w) is known where the fish swims and if V_f is known or can be estimated. The velocity of the water where the fish swim is usually termed "V-occupied" (V_{occ}). This is not the same as the mean velocity in a cross section of the culvert (Q/A). The writers' field studies of partially-full flow at two quite different culverts (Behlke et al., 1988, 1989; Kane et al., 1989) show that V_{occ}/V_{ave} may be 0.1 to 0.8 depending on location and conditions in the culvert. (Here V_{ave} is Q/A for the entire flow cross section under discussion.)

The writers' observations of fish swimming through culverts indicate that grayling try to pass through the short, difficult zone quickly with a velocity (V_f) of approximately 1 ft/sec. If outlet and/or inlet conditions are difficult, fish swimming in the white muscle mode must quickly get through the difficult, usually short, segment if they are to negotiate it at all. However, a culvert barrel is usually too long for fish to negotiate in the white muscle mode, so they are unable to move quickly through the barrel during times of fish passage design discharge (Q_f). The writers have observed design size grayling, in the red muscle mode,

moving through culvert barrels at velocities of approximately 0.1 ft/sec. Thus, fish apparently attempt to minimize P by minimizing V_f . It is the only thing in Equation 3.15 which fish can control when they have selected a swimming location in the culvert.

(Note: $V_{fw} = |V_w| + |V_f| = |V_{occ}| + |V_f|$)

Utilizing the analytical approach outlined previously, the writers computed power and energy expenditures for grayling movements through two culverts in Alaska. They also computed power and energy for Hunter's and Mayor's (1986) analysis of Jones' et al. (1974) data.

Table III-1 indicates the results of these computations.

Table III-1. Power and energy expenditures computed for grayling ($L_f = 240$ mm) at various locations in culverts studied by writers and for the Hunter and Mayor (1986) analysis of the Jones et al. (1974) data. For the latter, a culvert length of 100 ft, $V_{occ} = 2.0$ ft/sec, and $V_f = 0.1$ ft/sec are assumed. Asterisk denotes white muscle mode.

Location	Poplar Grove Creek (ft)	Fish Creek (ft)	Jones et al. (ft)
Culvert Length	110	60	100
Outlet P (Watts)	4.6*	1.6	---
Outlet E (Joules)	10.3*	3.1	---
Barrel P (Watts)	---	0.11	0.1
Barrel E (Joules)	---	167	108
Inlet P (Watts)	3.5* Est.	---	---
Inlet E (Joules)	4.1* Est.	---	---

III.G. Scale Effects

It is important to understand the effects of fish size (L) on (1) swimming *requirements* to pass through given passage conditions and (2) swimming *capabilities* to pass through the same passage conditions.

The power requirements for fish passage are represented by Equation 3.15. How fish size (L) affects the various forces of that equation is somewhat complex because for given hydraulic conditions, F_D varies as $L^{1.8}$, on the one hand, and F_G and F_{vm} , being proportional to W , vary as L^3 (see Equations 3.4, 3.9, and 3.10). However, a sense of the size implications can be investigated for fish of various lengths swimming in a culvert barrel which has small enough slope and water acceleration that F_G and F_{vm} are negligible.

For the above barrel conditions the power *requirements* ($P_{required}$) for swimming fish are:

$$P = F_D V_{fw}, \quad \text{-----Eq. 3.18}$$

so, for given hydraulic conditions (V_{fw}),

$$P_{required} \sim L^{1.8}. \quad \text{-----Eq. 3.19}$$

Thus, for example, the power a 300-mm fish must deliver in order to swim against a given barrel water velocity, as compared to that of a 240-mm fish confronted by the same hydraulic conditions, would be

$$P_{300 \text{ mm}} = P_{240 \text{ mm}} \left[\frac{300}{240} \right]^{1.8}. \quad \text{-----Eq. 3.20}$$

As a function of length, red muscle power *capability* (P_{cr}) of grayling (representative of Class-I fish) to swim at a given V_{fw} is determined by Equation 3.12. If Equations 3.4 and 3.12 are substituted into Equation 3.18, it is found that:

$$P_{cr} \sim L^{2.34}. \quad \text{-----Eq. 3.21}$$

Thus, red muscle power *capability* increases more rapidly than power *requirement* for the conditions outlined. This probably explains why large fish are observed to swim more rapidly (greater V_f) through a culvert than smaller fish do.

Little is known about the white muscle scale effects. The writers suggest the use of Equation 3.21 also for the power capability of grayling swimming in the white muscle mode simply because they have not been able to find any information supporting any other scale relationship. This assumption is open to disagreement and could be clarified or altered by future research on fish swimming energetics.

At some difficult inlet and outlet locations, F_G and F_{vm} can be significant and may be more important than F_D . Since these forces are proportional to L^3 while power capability is assumed proportional to $L^{2.34}$, smaller fish may face fewer difficulties at *some* culvert inlets and outlets than larger fish do.

IV. CULVERT HYDRAULICS AFFECTING FISH PASSAGE

Chapter Summary:

This chapter identifies the hydraulic elements which are important to fish passage through culverts. It defines the special conditions which must exist at culvert outlets, barrels, and inlets to allow *weak-swimming* fish to pass through the culvert. This chapter shows the importance of outlet pool water surface elevation on flow conditions in the culvert, and it develops design of downstream weirs to control the outlet pool conditions. It discusses the use of in-culvert weirs, offset baffles, and boulders for creating fish passage conditions in culverts otherwise too steep for fish passage. Equations are given that relate flow to geometric variables for those items where analyses have been possible.

IV.A. Overview

Upstream migrating fish must be able to and desire to swim into the culvert, upstream through the barrel, and out the culvert inlet. Chapter III summarized the swimming capabilities of grayling, a small design fish, and developed the drag, power, and energy implications to fish of swimming against hydraulic conditions which are commonly found at culverts. Fish passage culverts can best be designed if the designer attempts to view the problems faced by an upstream migrating fish from the viewpoints of the fish's capabilities and the hydraulic conditions which occur *where the fish swims*.

Chapter IV describes the hydraulic conditions which exist where fish actually swim in culverts. It relates these conditions to the fish's swimming capabilities to determine what hydraulic conditions are necessary for passage of the design fish through the structure. The fish's journey through the culvert is described by systematically related but hydraulically different segments (i.e., outlet pool, outlet, barrel, and inlet of the culvert). Since Q_f is generally much smaller than the maximum flood for which the culvert is designed, it is necessary to resort to basic open channel flow concepts to describe culvert hydraulics and to predict the expected effects of design alternatives on swimming fish. Always, however, the design engineer must keep swimming capabilities of the design fish in mind. As noted earlier, the best human analog of a swimming fish is that of a person's attempting to walk up a downward-moving escalator. By conceptually changing the speed and slope of the escalator, the designer can mentally feel forces, power, and energy analogous to those confronting the fish in different situations of culvert slope and water velocity. This analog, however, fails to describe virtual mass forces.

Some engineers may wish to review the elements of open channel hydraulics to feel comfortable with the discussions of this chapter. Since it is the mission of the writers to show how open channel hydraulic principles apply to fish passage and not to write a fluid mechanics or an open channel hydraulics text, the reader is referred to other authors for those disciplines. Many elementary engineering fluid mechanics texts have chapters on open channel flow which provide engineers with reviews of open channel fundamentals and, especially important, water surface profile shapes. The writers recommend Roberson,

Cassidy, and Chaudry (1988) for fundamentals and Chow (1959) for fundamentals and advanced topics.

During flow rates associated with fish passage, most culverts are partially full, relatively short open channels. The depth of flow is usually varied, i.e., the depth is not constant along the axis of the culvert. Knowing the depth of flow at various locations in the culvert is important for fish passage design. The water surface profile, and hence the depth at any longitudinal location in the culvert, depends on the relationship between the critical and normal depths and on a controlling depth of flow at some key location in the culvert. Thus, by controlling the relationship between critical and normal depth and simultaneously fixing the depth of flow at the key point (to be discussed), the water surface profile at outlet, inlet, and/or barrel can be controlled, though usually not independently, to achieve appropriate water velocity, acceleration, or water surface slope. Proper fish passage culvert design requires a knowledge of how to control the depth of flow at various key locations in the culvert.

IV.B. Culvert Outlet

IV.B.1. Critical Depth and Normal Depth

In open channel flow, critical depth (y_c) is defined as that depth of flow for which:

$$Q^2 \frac{B}{(g A^3)} = 1, \quad \text{-----Eq. 4.1}$$

where Q is the volumetric flow rate, B is the width of the water surface across the channel at a specific cross section, g is the gravitational acceleration constant, and A is the area of flow

at the specific cross section of the channel. The left side of Equation 4.1 is the square of the Froude number which relates inertial forces to gravity forces in open channel flow. If at a specific cross section $Q^2 B/(g A^3) > 1$, supercritical flow exists, and the flow depth (y) is less than y_c . If $Q^2 B/(g A^3) < 1$, subcritical flow exists, and the flow depth is greater than the y_c . If flow occurs at a depth equal to or greater than y_c , a hydraulic jump is not possible at that cross section of flow. Thus, if everywhere in the culvert $y > y_c$, a hydraulic jump is not possible in the culvert.

Normal depth of flow (y_n) in an open channel is defined as that depth for which:

$$Q = \left[\frac{1.49}{n} \right] A R^{2/3} S_o^{1/2} \quad (\text{ft}^3/\text{sec}), \quad \text{-----Eq. 4.2}$$

where n is the Manning boundary roughness factor, R is the hydraulic radius ($R = A/p$, where p is the length of the wetted perimeter of the cross section), and S_o is the slope of the culvert invert. Equation 4.2 is stated for foot-second units. For meter-second units, the 1.49 factor becomes 1.0. If the culvert does not slope uniformly, the normal depth depends on location in the culvert, but the critical depth is constant for the entire culvert so long as the culvert's prismatic cross-sectional shape does not change.

If the normal depth for a given Q and culvert slope, shape, and roughness is greater than the critical depth, hydraulically "Mild" water surface profiles ("M" profiles) are the only possibilities for gradually varied depths of flow along the culvert axis. If the normal depth is less than the critical depth, hydraulically "Steep" water surface profiles ("S" profiles) are the

only possibilities for gradually varied flow in the culvert. If the culvert invert slopes upward in the downstream direction, as many old culverts do near their outlets, hydraulically "Adverse" water surface profiles ("A" profiles) are the only possibilities. New culverts would seldom be designed to achieve M, S, and A water surface profiles simultaneously at different locations in the same culvert. Because of culvert settlement, existing culverts may have two or more of these profiles simultaneously at different locations in the culvert. Of concern to passage of weak-swimming fish is the fact that under some conditions depressed culverts with constant slope may have an M water surface profile at lower discharges and S water surface profile at higher discharges, though this is not often the case.

For passage of Class-I design fish such as grayling, computations reveal that supercritical flow usually overwhelms the fish's swimming capabilities. Hence, for weak-swimming fish, supercritical flow can seldom be tolerated in the culvert barrel but might be tolerated for a short distance at the culvert outlet. However, in situations of shallow flow (usually less than 1 ft), even if supercritical flow exists, the water velocity may be small enough to allow for fish passage. This very seldom occurs for fish passage design flow but may exist when normal depth is less than critical depth *and* the water velocity at normal depth is less than the safe water velocity for fish passage (Table IV-1).

Table IV-1. Discharges and velocities at various critical depths for a range of circular culvert diameters.

Culvert Diameter (ft)	Critical Depth (ft)	Q at Critical Depth (ft³/sec)	Average Cross-Sectional Velocity of Flow (ft/sec)
3	1	10.0	4.9
	2	37.8	7.6
6	1	14.6	4.7
	2	56.5	6.9
	3	123.1	8.7
	4	213.8	10.7
8	1	17.0	4.7
	2	66.4	6.8
	3	145.7	8.5
	4	252.8	10.1
	5	387.4	11.7
10	1	19.1	4.7
	2	75.0	6.7
	3	165.4	8.3
	4	288.1	9.8
	5	441.6	11.2
12	1	21.0	4.7
	2	82.8	6.7
	3	183.0	8.3
	4	319.8	9.7
	5	491.4	11.0
14	1	22.8	4.7
	2	89.8	6.7
	3	199.1	8.2
	4	348.8	9.6
16	1	24.4	4.7
	2	96.4	6.6
	3	214.1	8.2

IV.B.2. Outlet Hydraulic Conditions

Since outlet or downstream conditions of flow may dictate barrel conditions, the preceding brief discussion of desirable barrel conditions for fish passage is necessary to explain requirements for outlet flow conditions.

For a specific Q and culvert, the depth of flow at the outlet (Y_o) is governed both by the tailwater surface elevation of the outlet pool in relation to the invert elevation at the outlet (TW) and/or by upstream conditions of flow (Figure IV-1).

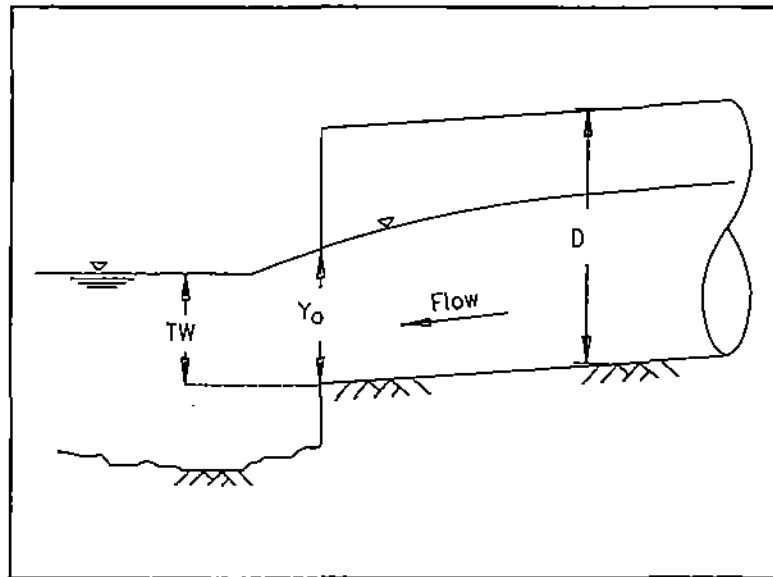

Figure IV-1. Culvert outlet area.

Since supercritical flow in the culvert barrel is usually unacceptable for small fish at fish passage design flow (Q_p), flow approaching the outlet from upstream must be subcritical, i.e., water velocities must be less than the critical velocity (V_c), except in very small diameter culverts (see Table IV-1). This means the depth of flow a few feet upstream from the outlet must be greater than y_c , which implies that the approaching flow must conform to an S-1, C-1, M-1, M-2, H-2, or A-2 water surface profile. M-2, H-2, and A-2 profiles are concave downward, slope downward in the downstream direction, and occur at depths greater than y_c . The M-2 profiles shown in Figure IV-2 do not act as the classical,

gradually varied flow equations indicate, because the gradually varied flow differential equation assumes hydrostatic pressure distribution at all depths. That is not the case as the M-2 curves of Figure IV-2 approach the culvert outlet. These regions of rapidly varied flow at the lower ends of the M-2 profiles are indicated by broken curves. Any discussion of the M-2 profile can be extended to the H-2 and A-2 profiles.

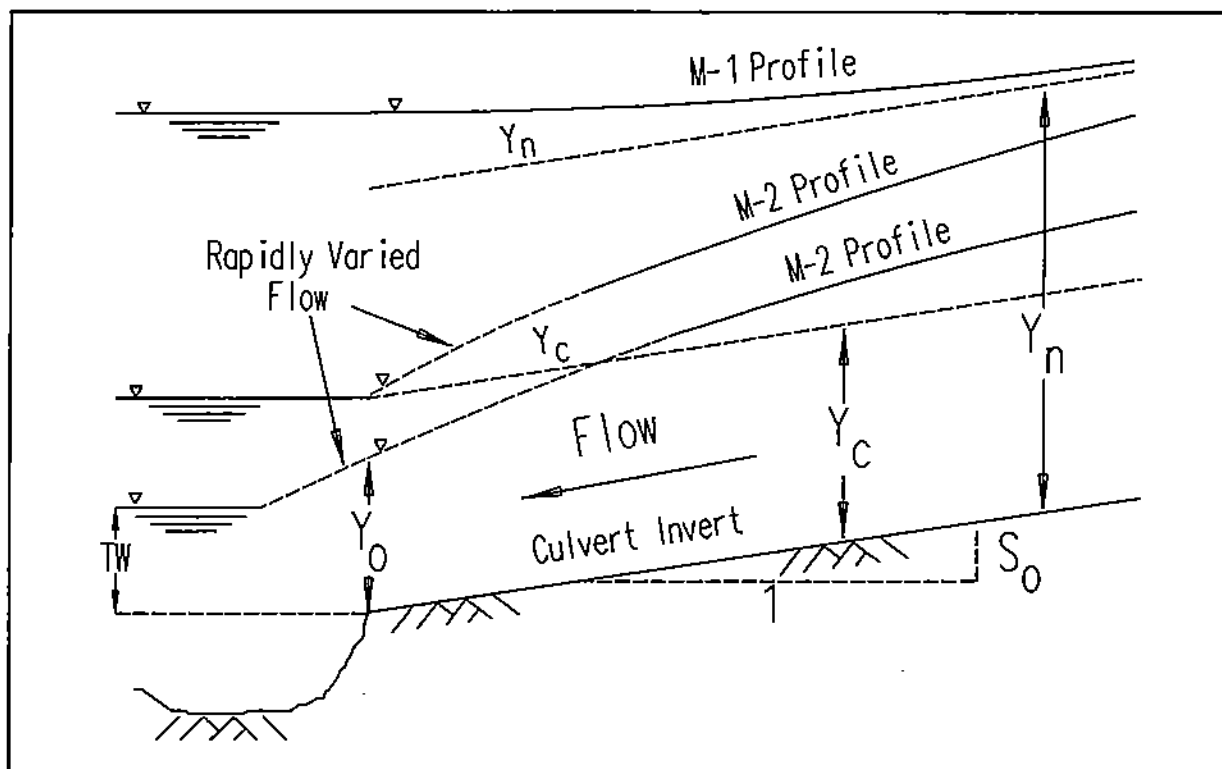

Figure IV-2. Water surface profiles and depths at culvert outlet as related to tailwater elevation (TW). M profiles occur because $y_n > y_c$.

The S-1, C-1, and M-1 profiles produce depths greater than y_c , and the depth decreases in the upstream direction approaching y_n . Thus, water velocities increase, though not linearly, with distance upstream from the outlet. M-1 profiles extend upstream close to the culvert inlet while the S-1 and C-1 profiles are shorter and may not extend to the culvert inlet.

The gradually varied flow water surface profiles (M-1, M-2, etc.) result from integration of the differential equation of the slope of the water surface. That differential equation assumes hydrostatic pressure distribution at each cross section. For the water surface profiles shown in Figure IV-2, the M-2 curves cease to be classical M-2 curves as the water surface approaches y_c from the upstream direction. This is because relatively strong accelerations occur in the downstream direction, and the pressure distribution with depth is not linear. This region of rapidly varied flow is indicated by dashes in Figure IV-2.

If a culvert is perched or partially perched, and subcritical water velocities occur as flow approaches the outlet, only M-2, A-2, or H-2 profiles, which begin a short distance upstream from the outlet, can exist upstream in the culvert. Also, if the culvert is perched, the pressure distribution across the flow cross section at the outlet is much less than hydrostatic. This results in less than critical depth at the outlet. Simons, Stevens, and Watts (1970) show how outlet depth for circular culverts of diameter D varies with TW/D . Their results are also shown in "Hydraulic Design of Energy Dissipators for Culverts and Channels" (1983).

For a rectangular channel in which an H-2 profile exists, Rouse (1938) has shown that critical depth occurs upstream from the free outfall a distance equal to 4 to 5 critical depths, and the depth at the outfall is $0.715 y_c$. The writers' analysis of Simons et al. (1970) results indicate that for perched culverts the outlet area of flow is approximately $0.71 A_c$, where A_c is the cross-sectional flow area for critical depth. Thus, water velocities at the outlet of an outlet-controlled, perched culvert are $V_c/0.71$. Consequently, profile drag forces on fish may be quite considerable here. Additionally, buoyancy alteration and water acceleration

can result in considerable gradient force and virtual mass force problems for fish at the outlet of a perched culvert. Since fish have great difficulty entering a perched culvert, this outlet condition is not an option for new culvert design. For some existing perched culverts, outlet problems may be eliminated by retrofitting as discussed later.

If $y_c > TW > 0$, the outlet can be classified as partially perched (Behlke, 1987), because some backwater pressure effects exist at the outlet. Simons et al. (1970) indicate how the outlet depth varies with TW/D . For M-2, A-2, and H-2 upstream profiles, increasing TW to y_c , from that TW which results in $A_o = 0.71 A_c$, has the effect of moving the critical depth toward the outlet from where it would be located for perched conditions (A_o = outlet cross-sectional area of flow). This is important for fish attempting to enter a partially perched culvert (assuming barrel velocities are acceptable for fish passage), because it reduces the distance which the fish must swim against excessive velocities.

The writers' field observations lead them to believe that design length grayling cannot generate the elevated power outputs (P) necessary to overcome high water velocities (profile drag) and the accompanying gradient and virtual mass forces for a distance of more than 2-3 ft. Therefore, the writers suggest that the design TW never be less than y_c and, generally, that it exceed y_c for passage of Class-I fish.

IV.B.3. Control of Culvert Outlet Tailwater Elevation

If an M-1, M-2, A-2, or H-2 water surface profile exists in the barrel, the culvert outlet depth (Y_o) can be increased above that for a perched culvert by control of the tailwater depth (TW). Since critical depth or greater is usually necessary for acceptable outlet conditions for Class-I fish, the invert of the culvert tube can be set lower than the elevation of the natural streambed. Subsequent partial filling by stream sediments then can widen the cross-sectional area of flow for Q_f and increase the composite Manning n factor. This allows a smaller outlet pool elevation for fish passage discharge. Thus, this design helps to avoid outlet control problems. In order to estimate Y_o for a given outlet invert elevation and the range of discharges expected for the stream, it is desirable to develop a rating curve for the stream at the outlet location. This is best achieved using stream gaging methods to make a few discharge measurements while simultaneously recording the proposed outlet pool's water surface elevation for each discharge. For the purposes of culvert design, the stream rating curve is expressed as:

$$y = K Q^x, \quad \text{-----Eq. 4.3}$$

where K and x are numbers whose average values over the range of discharges for fish design flows can be estimated from the stream gaging results by plotting y against Q on log-log paper. x is the real slope of the curve and K is the value for y where $Q = \text{unity}$ on the plotted curve. Only a few points at small discharges, in the vicinity of $Q = Q_f$ and less, are sufficient to define the element of the curve essential for fish passage. It is, of course, important for new construction that the rating curve be defined for the site which will define the outlet pool control for the new culvert *following* its installation.

If a rating curve cannot be developed from a few discharge measurements, an approximate one can be developed from a survey of the site and appropriate use of the Manning equation. The details of this approach are developed and explained in "Hydraulic Design Series No. 8, Culvert Analysis, Microcomputer Programs Applications Guide (and software)" (1987). That document includes appropriate software for identifying necessary input data and calculating a rating curve.

When the tailwater rating curve has been established, the outlet water surface elevation (Y_o) can be determined for a trial outlet invert elevation for Q_f . The ideal outlet is realized when $TW \geq y_{avef}$ for fish passage design flow (Q_f). If this relationship exists, *and* the barrel has been properly designed, the outlet is safe for fish passage and no additional attention to the outlet is required.

If $Y_o < y_{avef}$, the red muscle swimming capacity of the fish is exceeded, and the fish must use white muscle power and energy to progress upstream to the point where $y = y_{avef}$ and the outlet zone ends. How much power and energy are required depends on the severity of the hydraulic conditions in the culvert between the outlet lip and the upstream end of the outlet zone.

For $y_c \leq Y_o \leq y_{avef}$, water acceleration exists in the outlet zone. This changes cross-sectional velocity distributions in the outlet zone. In the barrel of structural steel plate (SSP) culverts the writers consider it safe to assume that $V_{occ} = 0.4 V_{ave}$. However, in zones of

water acceleration, velocity distributions tend to flatten, so this relationship is not valid in the outlet zone. In extreme outlet zone accelerations the writers have found $V_{occ} = 0.8 V_{ave}$.

Thus, if water acceleration exists, the value of V_{occ} at a specific cross section of the outlet zone lies in the range of 0.4 to 0.8 V_{ave} . The higher of these two values would occur at the culvert outlet under conditions where the difference between y_c and y_{ave} is large. For smaller values of this depth difference, V_{occ} at the outlet lip would be defined by

$0.4 V_{ave} \leq V_{occ} \leq 0.8 V_{ave}$. Unfortunately, the writers do not have data which would provide a more precise relationship. Thus, the design engineer must make a judgment decision of the magnitude of V_{occ} at the outlet lip. (The details of outlet hydraulic design are addressed in more detail in Chapter V.)

When the outlet zone hydraulics have been defined, power and energy requirements for the fish to pass through the trial outlet conditions can then be calculated for the fish's entrance to the culvert. If the tailwater depth (TW) is so low that outlet conditions impose impossible power and energy requirements on the fish, it must be increased in relation to the culvert invert by lowering the entire culvert and/or increasing the outlet pool tailwater elevation for all fish passage flows Q 's. Lowering the culvert elevation is usually easy for proposed culverts but is, of course, out of the question for existing culverts. However, it is possible to install an artificial, depressed invert in an existing culvert. (This may also require changing the outlet pool control.) If, for a new culvert, the designer decides the trial outlet invert elevation must be reduced, it must be remembered that the outlet is only one part of

the culvert system, and other changes will also have to be made in the barrel and inlet elevations of the culvert.

When the design of the culvert outlet velocity is made acceptable for fish passage, possible erosion downstream from the outlet should be checked by methods outlined in "Hydraulic Design of Energy Dissipators for Culverts and Channels" (1983). Downstream erosion problems may not exist for Q_f , but potential downstream erosion from maximum design flows should certainly be checked. If the outlet depth (Y_o) is such that erosive water velocities occur as water enters the tailwater pool, downstream erosion can alter the tailwater rating curve for the outlet pool. Such alterations can destroy the culvert outlet's acceptability for fish passage purposes. Thus, it may be necessary to reduce culvert outlet velocities for maximum design flows by increasing the size of the culvert or by lowering the culvert elevation. The ideal situation is to have outlet water velocity equal the tailwater stream velocity for all discharges. However, that is virtually impossible to achieve. Rip-rap lined outlet pools are an effective method of protecting the channel in the deceleration zone for high velocity water leaving the culvert.

The outlet pool rating curve can be altered by employing downstream weirs as described by Dane (1978) or as described herein later, or by means of alternately offset gabion groynes to achieve the necessary increase in outlet pool elevation (Carlson and Blevins, 1989). Stream bed material trapped behind weir structures usually does not defeat the fish passage purpose of such structures, because it, too, raises the water surface elevation at the culvert outlet.

As an example of a gabion weir alternative, the writers have successfully designed the retrofit of a perched culvert. This consisted of raising an outlet pool elevation by means of a cross-channel, tapered gabion weir with a V-notch in its center. The gabion has a wide-angle V-notch weir, which backs sufficient water into the culvert during times of Q_f , and a sharp V-notch in its center which concentrates the flow at low discharges for fish passage.

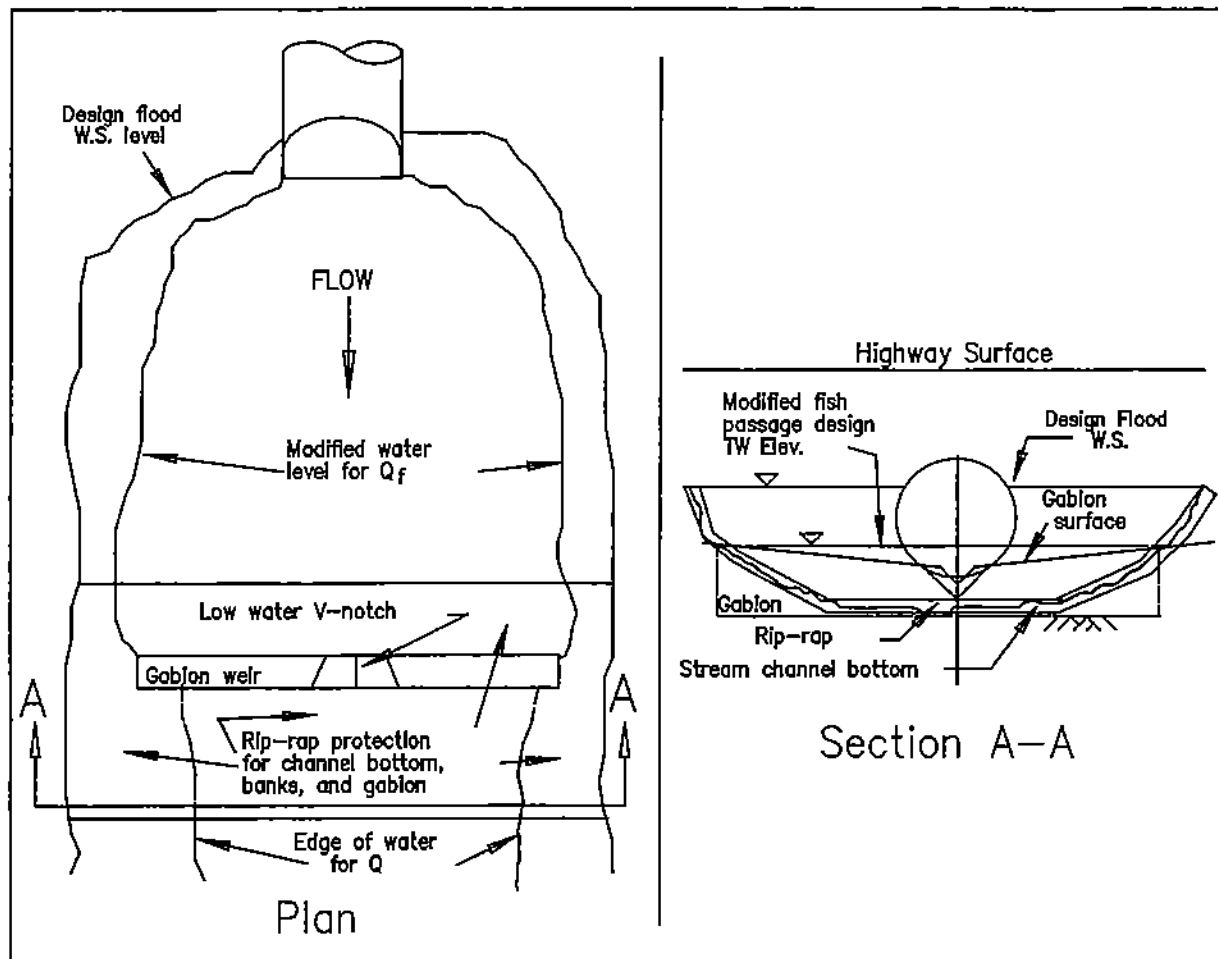

Figure IV-3. Example of gabion weir to create higher tailwater elevation (TW) at culvert than that generated by the stream. More than one such weir in series may be required to achieve appropriate tailwater elevation.

The cross-channel weir must be designed to accommodate Q_f . The top of the outer edges of the weir should be set at the desired outlet pool elevation for Q_f (Figure IV-3). If sufficient

cross-channel space does not exist for this, the cross-channel slope of the weir must be reduced to allow for more flow and create a greater than zero depth at the outer edges of the weir for Q_f . The inner, more pronounced V-notch weir should be designed so that its head is sufficient to back water up into the culvert outlet at low flows. Thus, the fish can negotiate the weir and outlet at very low flows. The drop in water surface elevation from upstream to downstream of an individual weir should not be greater than 1 ft. Thus, it may be necessary to locate more than one of these weirs in series. At any rate, one or more weirs must back water up enough to create a safe depth of flow at the culvert outlet.

Additional details of retrofit design for existing culverts which do not allow fish passage will be discussed in Chapter VI.

IV.B.4. Gabion Weirs

IV.B.4.a. Flat Gabion Weirs

A gabion weir is usually 2-3 ft thick. Therefore, it has characteristics more like those of a broad-crested weir than of a sharp-crested weir. Since gabion weirs are used to increase the tailwater elevation of a culvert outlet pool, a drop in stream water surface elevation occurs for flow over the weir into the downstream channel or other pool. More than one weir may be needed to raise the culvert outlet pool to the necessary elevation for fish passage through the culvert. The water surface elevation just downstream from the farthest downstream weir is that of the stream at normal depth of flow for the design flow rate. The water surface elevation just upstream from the farthest upstream weir is the tailwater for the culvert outlet and is determined by the geometry of the weir (or weirs), the discharge, and, perhaps, the

downstream water surface elevation in the stream. Any drop in water surface elevation through a weir is accompanied by an increase of kinetic energy of the water flowing over the weir. For example, if the water surface drops 1 ft through a weir, the velocity head ($V^2/2g$) of the water exiting the weir is increased by 1 ft if no losses occur through the structure. This means that at the outlet of the weir a velocity of approximately 8 ft/sec would be achieved if the approach velocity head is small. Weak-swimming fish could pass this velocity barrier only if it is very short in extent, because they must use white muscle power to negotiate the barrier.

For a flat, thick gabion weir the same argument exists for the occurrence of local critical depth *at all locations* on the crest as it does for any rectangular, two-dimensional broad-crested weir. Thus the water velocity must be V_c on the crest of the weir (or less if too much backwater exists and “drowns out” the weir). Assuming no backwater effect from downstream, a condition of critical depth of flow on the weir crest is that $(V_c)^2/2g = 2y_c$. From energy considerations, assuming negligible approach velocity head and no approach losses, $h_p = (3/2)y_c$, where h_p is the elevation of the pool surface, just upstream from the weir, with respect to the top of the weir. Thus,

$$V_c = \left[(2g) \left[\frac{h_p}{3} \right] \right]^{1/2} . \quad \text{-----Eq. 4.4}$$

The discharge (Q) for this type of rectangular, broad-crested weir is the product of the water velocity on the weir (V_c), the depth of flow on the weir (y_c), and the length of the weir perpendicular to the flow (B). That is:

$$\begin{aligned}
 Q &= B y_c V_c \\
 &= B \left[\left(\frac{2}{3} \right) h_p \right] \left[(2g) \left(\frac{h_p}{3} \right) \right]^{1/2} \quad \text{-----Eq. 4.5} \\
 Q &= 3.1 B (h_p)^{3/2}
 \end{aligned}$$

Equation 4.5 can be used for design purposes by substituting the fish passage flow (Q_f) for Q . The acceptable h_p for fish passage can then be determined from Equation 4.4 for any acceptable water velocity on the weir, so the length of weir (B) can be calculated for any upstream pool elevation (h_p).

IV.B.4.b. V-Shaped Gabion Weirs

V-shaped gabion weirs (Figure IV-4) do not conform to normal sharp-edge weir formulas. Such weirs have properties similar to broad-crested weirs, because the depth of flow at each location on the weir surface is the unique critical depth for that location. However, because the head on the weir varies from a maximum at the center of the gabion V to a minimum value at each outside edge of the weir, the critical depth varies spatially along the top surface of the weir. In order to determine the discharge from a V-shaped, broad-crested weir, it is necessary to define a differential discharge at each location on the weir and integrate that discharge from one end of the weir to the opposite end.

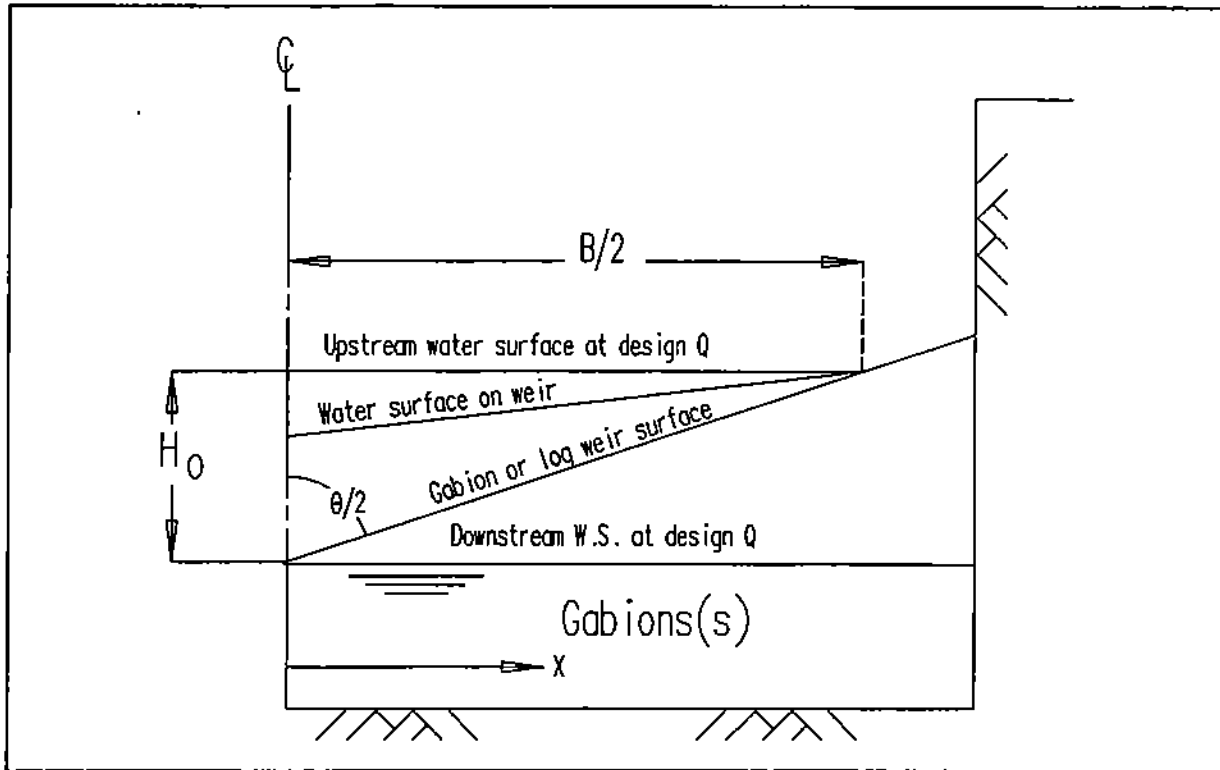

Figure IV-4. View from downstream of flow over right half of V-shaped, gabion, broad-crested weir.

Since one side of the V-shaped broad-crested weir is a mirror image of the other, the development which follows will be for one side of the weir and the result will be doubled to determine the total discharge (Q) across the weir. The following derivation assumes that the water surface elevation downstream from the weir is less than that upstream from the weir by at least $H_0/3$ (Figure IV-5), but the downstream water surface elevation must not be lower than that upstream by an amount greater than H_0 . The derivation is for *one-dimensional flow*, so cross-channel flow due to the cross-channel water surface slope on the weir is ignored. In most cases, the weir angle (θ) is rather large, so the cross-channel slope of the top of the weir is small. This should result in minimal cross-channel flow.

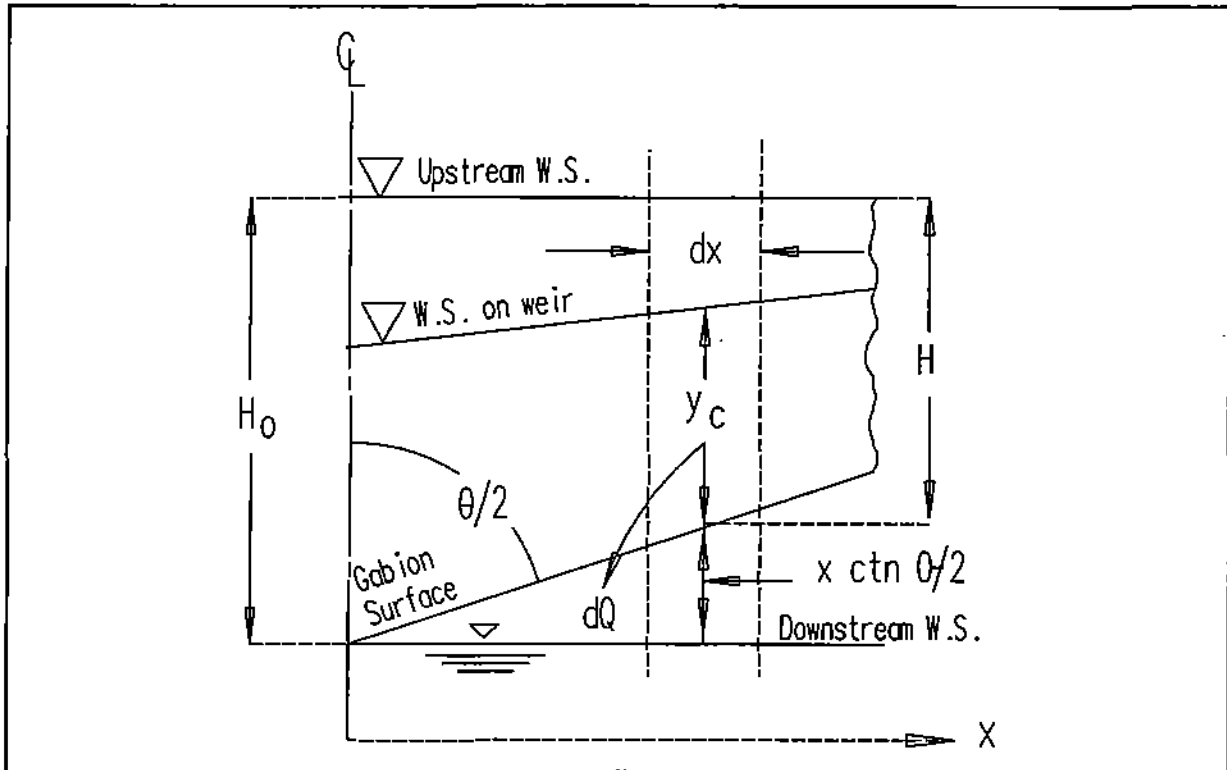

Figure IV-5. Differential element of discharge (dQ) passing over differential width (dx) of gabion weir.

Since at each location on the weir the depth of flow is assumed to be the local critical depth (y_c) and approach kinetic energy and losses are ignored, the local head on the weir (H) is the specific energy on the weir at that location. That is, at each location on the weir,

$$H = y_c + \frac{V_c^2}{2g}, \quad \text{-----Eq. 4.6}$$

where $H = H_0 - x \text{ ctn } (\theta/2)$.

Figure IV-5 indicates a differential element of flow area at a location (x) from the center of the weir. Since critical depth and velocity are assumed to exist at all points on the weir, the element of flow is:

$$dQ = V_c y_c dx. \quad \text{-----Eq. 4.7}$$

Since critical conditions exist at all points on the weir, $y_c = \frac{2}{3} H$, and $\frac{V_c^2}{2g} = \frac{H}{3}$.

Substituting these values for V_c and y_c into Equation 4.7,

$$dQ = \left[2g \frac{H}{3} \right]^{1/2} \left[2 \frac{H}{3} \right] dx. \quad \text{-----Eq. 4.8}$$

If the weir consists only of a V-section with no vertical side walls, $H = H_o - x \operatorname{ctn} (\theta/2)$,

so Equation 4.8 becomes:

$$dQ = \left[\frac{2}{3} \right] \left[\frac{2g}{3} \right]^{1/2} \left[H_o - x \operatorname{ctn} \left[\frac{\theta}{2} \right] \right]^{3/2} dx. \quad \text{-----Eq. 4.9}$$

Integration of this expression and doubling the result to provide for both sides of the weir result in:

$$\begin{aligned} Q &= 2 \left[\frac{2}{3} \right] \left[\frac{2g}{3} \right]^{1/2} \left[\frac{2g}{3} \right]^{1/2} (H_o)^{5/2} \tan \left[\frac{\theta}{2} \right] \\ &= 0.44 (g)^{1/2} (H_o)^{5/2} \tan \left[\frac{\theta}{2} \right]. \end{aligned} \quad \text{-----Eq. 4.10}$$

If the weir has side walls (Figure IV-6), the discharge can be determined by first calculating a hypothetical discharge by means of Equation 4.10 and then subtracting from it another hypothetical discharge calculated by substitution of H' instead of H_o into Equation 4.10.

Thus, for broad-crested, V-type weirs with side walls:

$$Q = 0.44 (g)^{1/2} \left((H_o)^{5/2} - (H')^{5/2} \right) \tan \left[\frac{\theta}{2} \right]. \quad \text{-----Eq. 4.11}$$

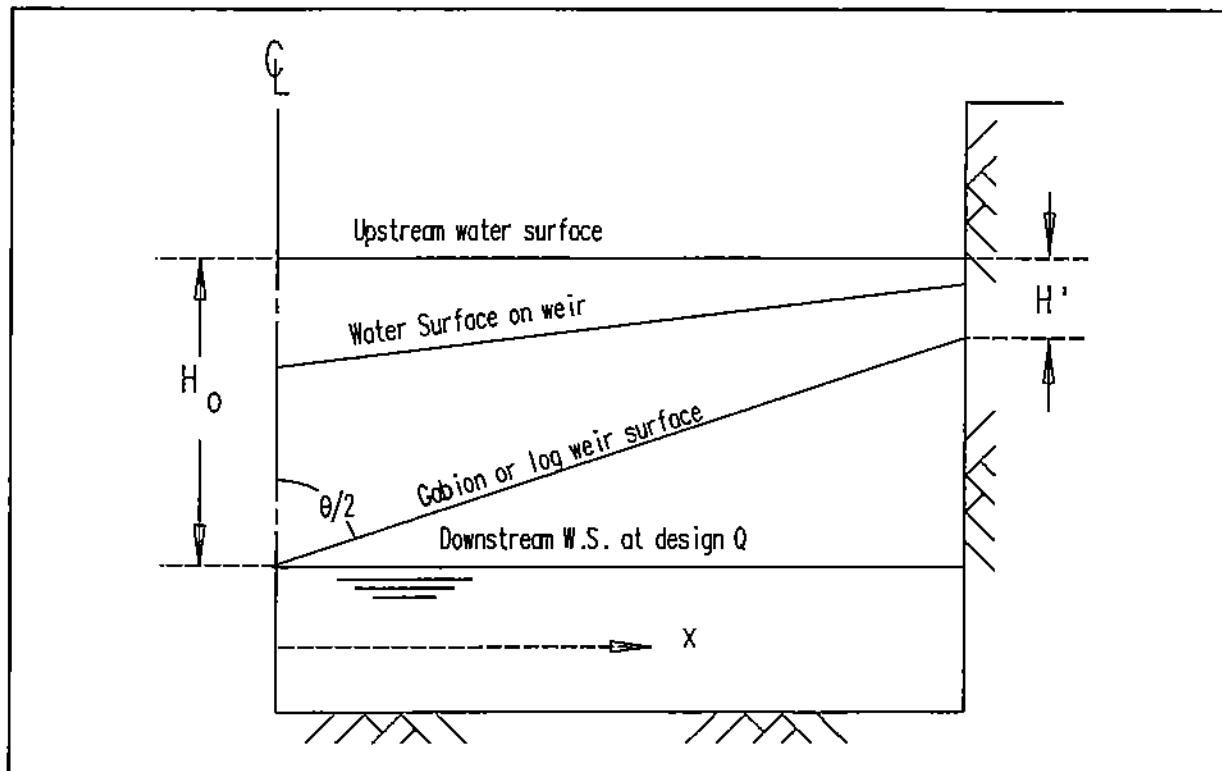

Figure IV-6. One side of V-shaped gabion or large-log weir with vertical side walls at channel edges.

The writers' observations of broad-crested weirs indicate that the width of the weir surface (in the direction of flow) should be minimized, because fish leaping from the downstream pool onto the high velocity flow on the weir must swim through it to get into the upstream pool. If the weir crest is too broad, fish may not be capable of moving beyond it.

Flow from broad-crested weirs may plunge from the weir crest into the receiving pool, or the flow may enter the downstream pool in a streaming fashion. Fish must leap farther horizontally for plunging flows than for streaming flows. An advantage of V-type weirs is that the flow through the center of the weir may be streaming as it leaves the weir while flow toward the outside edges of the weir plunges into the receiving pool. Thus, fish can choose what conditions to attempt.

If it is impossible to raise a perched culvert's outlet pool sufficiently by means of one gabion weir, others can be added in series as outlined by Dane (1978) for low, rectangular weirs. However, channel bottom protection must be provided upstream, downstream, and at the edges of each weir.

It is important that the water surface drop from the pool upstream of the weir to that downstream from the weir be no greater than 1 ft if *weak-swimming* fish must pass over the weir. Solving a culvert outlet problem is not a solution if the upstream-moving fish are unable to get to the culvert tailwater pool.

Channel bottom protection upstream and, especially, downstream from gabion weirs cannot be overemphasized. If rip-rap or other protection is not provided, the gabion foundation and channel sides will probably be eroded. Thus, the culvert tailwater control provided by the gabion weir structure will be lost. End protection for gabion weirs located in streams where the streambed widens appreciably for flows greater than Q_f must be extended beyond the weir sufficiently to provide end protection from erosion.

IV.B.5. Submerged Log Weirs

Submerged log weirs have many of the same features as gabion weirs if the log has a uniform large diameter which has been sawed flat on the upper surface, or if two logs are placed side-by-side across a channel to provide a weir. Log weirs are generally used in a retrofit situation where it is necessary to increase the culvert outlet pool water surface

elevation. This normally occurs where there is a perched culvert which fish are unable to enter.

A single-log, submerged weir can provide a better situation than a gabion weir, because its crest can be narrower than that of a gabion weir. Flow over a single, circular log weir occurs at the critical depth on the log crest if the weir is not hydraulically submerged.

However, the flow plunges more rapidly than it would over a gabion weir, so fish leaping over the weir do not have as far to travel upstream as they would in attempting to pass over a gabion weir. Discharge and water velocities over a log weir can be calculated by use of Equations 4.6 and 4.10.

Advantages of log weirs are that they are simple and that they provide a surface which debris does not readily adhere to. Disadvantages are that they can be difficult to anchor so that they remain locked into the bottom of the stream and that those segments of the weir which are not permanently submerged will biologically degrade with time.

IV.C. Culvert Barrel

IV.C.1. Overview

Except, perhaps, for a short distance at the outlet and inlet ends of the culvert barrel, flow usually varies gradually in the barrel. For this reason virtual mass forces can usually be ignored there. Culvert barrels without baffles, weirs, or other types of flow-retarding devices cannot achieve slow enough water velocities to allow passage of weak-swimming fish unless the culvert slope (S_o) is small. The allowable slope depends on culvert diameter,

roughness, and depression (if any). Since the gradient force (F_G) for such small slopes of the hydraulic grade line (HGL) is negligible in relation to the profile drag force, it can be ignored for fish swimming in the barrels of plain culverts. Since the profile drag force is governed only by V_{fw} for a given fish and water temperature, a safe water velocity for the assumed V_{occ} can be selected without regard for water acceleration or HGL slope for a design fish subjected to long periods of swimming in a culvert barrel. This is not true in artificially roughened, steep culverts. Earlier it was assumed that $V_{occ} = 0.4 V_{ave}$. Thus, the desired V_{occ} can be converted to a suitable upper-limit design value for cross-sectional average velocity (V_{avef}), which depends on the swimming capabilities of the design fish. The minimum design value for a cross-sectional area of flow for fish passage then becomes $A_f = Q_f / V_{avef}$. This cross-sectional area occurs at a depth of flow, y_{avef} , which should be less than or equal to the normal depth (y_n), depending on the velocity at these depths, but it would seldom be less than the critical depth (y_c), for reasons previously outlined.

Generally, water velocities in culvert barrels will be too great for effective passage of Class-I fish if other than hydraulic M-1, M-2, A-2, or H-2 water surface profiles exist there.

However, these water surface profiles are unacceptable if they result in velocities which fish cannot negotiate. An S-1 profile is occasionally acceptable if that profile extends upstream from the outlet to the inlet, thus precluding supercritical velocities in the culvert. However, the S-1 profile should not be considered for new culvert design. For existing culverts which support inlet control and downstream S-2 water surface profiles, outlet retrofitting may result in a satisfactory S-1 profile. Under some circumstances, retrofitting with additional barrel

roughness, which will be discussed in Chapter VI, can result in an acceptable M-2 profile.

(Of course, any retrofitted culvert must still provide for safe passage of the design flood.)

The existence of subcritical water velocities in a culvert barrel, except for very small depths, is a necessary, but not the *only*, condition for passage of Class-I fish through a culvert barrel. This matter is addressed in Chapter V.

Various M water surface profiles in the vicinity of a culvert outlet are shown in Figure IV-2.

For M-2, A-2, and H-2 profiles upstream, significant water acceleration and water surface curvature may exist close to the outlet. Water surface profiles for the barrel are simply upstream extensions of those previously discussed for the outlet. However, between the short outlet and inlet zones (2-6 ft), if hydraulic jumps are not present, gradually varied flow exists and only insignificant (to fish) water accelerations are present. If it is also assumed that fish do not accelerate in the barrel, virtual mass forces (F_{vm}) on the fish can be ignored there. Thus, only gradient and profile drag forces need be considered when analyzing energy and power requirements of fish swimming in most barrel situations.

M-2 water surface profiles in the barrel offer some advantages over other profiles, because water depths increase and velocities decrease with distance upstream from the outlet. This provides conditions which improve somewhat for fish as they move upstream. An additional benefit to M-2 water surface profiles is that outlet tailwater elevations (TW) need not be as great as for M-1 profiles. If conditions are such that culverts can be set low enough to generate an M-1 profile in the culvert, that water surface profile results in smaller water velocities than for a corresponding M-2 profile for identical conditions of culvert slope and

size. However, because the culvert can be set higher, the conditions which create an M-2 profile will usually be more attractive to designers than will be those for an M-1 profile.

Culvert barrels are much longer than the previously discussed outlet zone, so weak-swimming fish cannot swim in the white muscle mode through the entire barrel. Behlke (1987, 1989) has hypothesized that fish do not know in advance the length of all but the shortest of culverts, so they appear to adopt a strategy of minimizing their power outputs consistent with slowly moving upstream. Observations by the writers and other investigators (Tilsworth and Travis, 1988; Behlke, et al., 1988; Behlke, 1988; Kane et al., 1989) indicate that grayling sometimes spend as much as 45 min moving through a 110-ft culvert. For the 240-mm (9.5-in) fork-length design fish, the writers suggest that designers assume $V_f = 0.1$ ft/sec for forward progress of these Class-I fish through the culvert barrel (if the fish is capable of moving ahead in the barrel). Thus, for calculations of fish power and energy the writers assume a design grayling would use 1000 sec (16 $\frac{2}{3}$ min) to move through a 100-ft culvert.

IV.C.2. Normal and Critical Depths

For a specific culvert geometry, the critical depth is a function only of Q . On the other hand, normal depth for a specific culvert geometry is a function of Q , culvert roughness, and slope. For mild sloping culverts the normal depth (y_n) is greater than the critical depth (y_c). For fish passage, M-2 and M-1 water surface profiles in culvert barrels are the most attractive. The M-2 profile lies between the loci of y_c and of y_n in the barrel. The fact that depths greater than y_c exist for some distance in the barrel does not automatically mean that

safe fish passage conditions exist there. For passage of Class-I fish, it is often necessary to reduce velocities well below V_c .

Increasing culvert roughness and/or reducing culvert slope increases the difference between y_c and y_n , raising the M-2 or M-1 profile vertically upward. This decreases cross section water velocities (V_{ave}) at every cross section on those water surface profiles. Methods of increasing roughness will be discussed later.

IV.C.3. Where the Fish Swim

Having observed many grayling and other fish swimming as they enter, swim through, and exit culverts, the writers are convinced that fish seek and find the best locations for swimming. This is understandable, since their survival depends, in part, on their skills at finding the easiest locations for swimming.

Figure IV-7 shows a typical water velocity profile of a culvert barrel cross section. Because the gradient force on a fish depends on the slope of the HGL, it is relatively constant for all locations in a culvert cross section. Thus, the easiest location for fish to swim is at the edges of the cross section close to the water surface where water velocity and profile drag are minimal.

The writers have observed fish swimming in these locations, and, unexpectedly, the swimming fish were observed to orient their bodies normal to the sloping culvert wall and parallel to the water surface and culvert axis with their bellies against the culvert wall

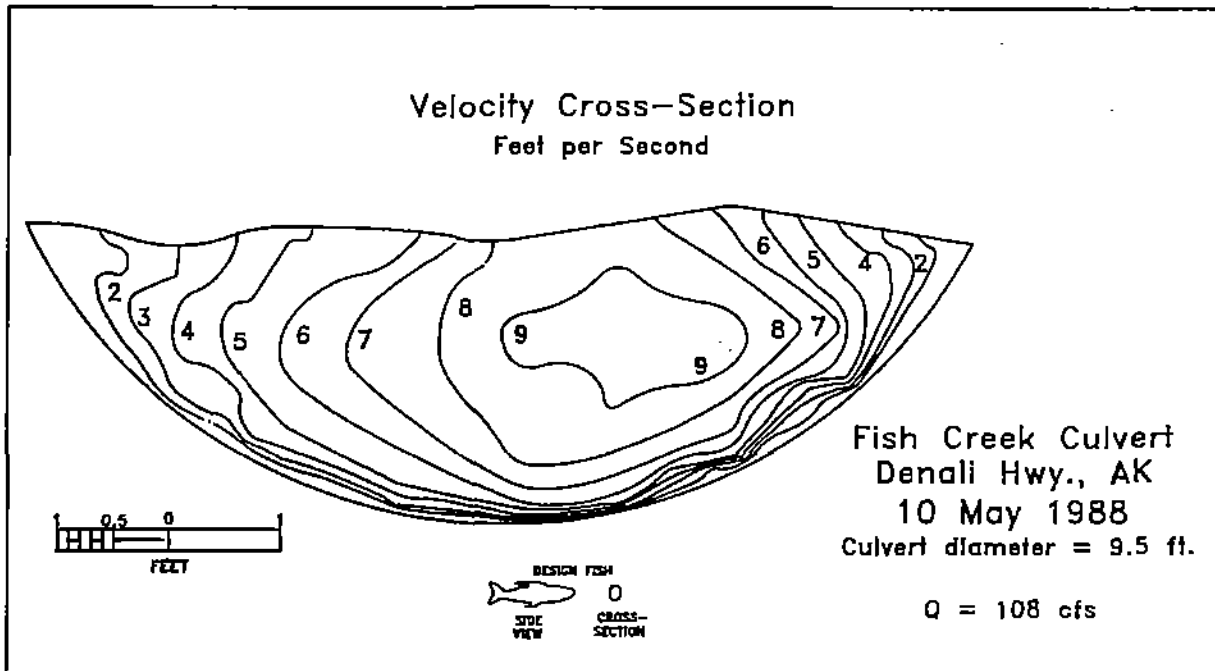

Figure IV-7. Water velocity cross section (measured by writers) in a 9.5-foot diameter culvert at Fish Creek, Denali Highway, Alaska.

(Figure IV-8). The writers guess that this orientation is for one of three reasons: (1) for protection from predators they like to swim with their light colored bellies close to the wall so, from a distance, their camouflaged backs blend with the darker culvert walls; (2) they prefer to swim with their bodies oriented with the water velocity gradient from the culvert wall; or (3) they orient themselves normal to their substrate, which here is the culvert wall.

The water flowing in the wedge-shaped zone of the culvert shown in Figure IV-8 is strongly influenced by the boundary frictional effects of the culvert corrugations graphically illustrated in Figure IV-7. The shape of this wedge is obviously important to swimming fish. If the lower boundary of the wedge (the culvert wall) does not slope a great deal, favorable boundary effects are greater than if the boundary sloped more. Thus, for fish passage design flow, it is best if the culvert wall slopes little as it approaches the water surface at the edges of the water surface. If the water surface elevation in a circular culvert is less than $0.3 D$

above the bottom of the culvert, conditions within the wedge-shaped zone are best for swimming fish. The writers suggest $0.3 d$ as an approximate upper limit for water depths for Q_f . Random current meter measurements on a few pipe-arch culverts lead the writers to believe that type of culvert does not exhibit these characteristics. At their sides such culverts do not possess the wedge-shaped zone of partially full circular or elliptical culverts.

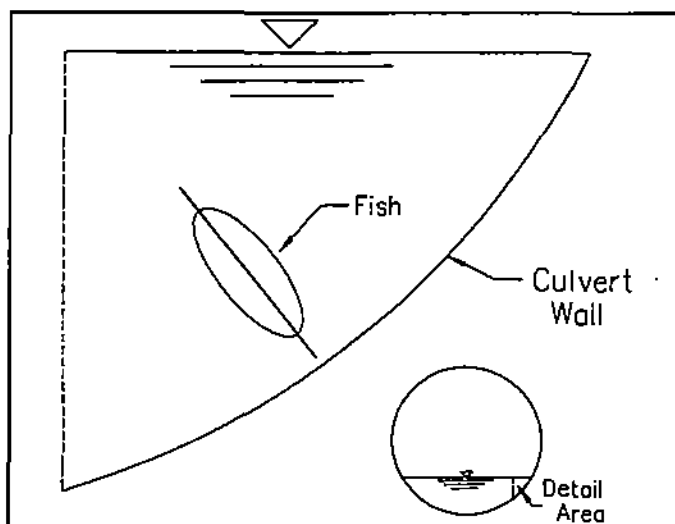

Figure IV-8. Favorable wedge-shaped location at edge of culvert near water surface where corrugation roughness slows water velocities. Sketch is of fish as they have been observed to swim in this location.

Elliptical culverts exhibit better characteristics for water velocity reduction than do circular culverts. They possess the ideal barrel conditions for fish passage if the water surface elevation above the invert is less than three-tenths the length of the vertical axis of the ellipse. Elliptical culverts also have better outlet characteristics for fish passage than other culvert shapes, because they allow specific discharges to flow at shallower depths and wider water surface widths (B) than for other culvert shapes. Thus, outlet velocities can be kept relatively small for the same outlet invert elevation than for circular culverts. Also, gradient and virtual mass forces on fish at the outlet are less than for the same discharge in an equivalent circular culvert. This is *not* to say that circular culverts and circular depressed-invert culverts should be abandoned in favor of elliptical culverts. However, in marginal situations where circular culverts would somewhat exceed desired water velocities or outlet

depths, use of elliptical culverts may be more economic than weir baffles or downstream backwater improvements for a circular culvert. If elliptical culverts are proposed to reduce highway fill depths, they are certainly amenable to fish passage if properly designed for Q_f .

Culvert inverts can be depressed lower than the surrounding stream channel elevation and backfilled with rip-rap, coarse gravel, or discrete, large boulders to enhance culvert roughness. The resulting composite invert may itself be depressed lower than the surrounding streambed to increase the cross-sectional area of flow for all discharges.

Artificial baffling may be located in the bottom of the culvert to provide roughness that slows water velocities near the invert and increases the overall Manning n factor for the culvert.

All of these methods of enhancing culvert roughness result in increased water depths in the culvert for all flows, though the increase in depth is usually most pronounced for lesser Q 's.

Thus, increased roughness at the bottom of culvert barrels helps fish pass through the lower flows (Q_f or less). It does not greatly reduce the capacity of the culvert to carry design flows.

Engineers designing retrofits for culverts must ensure that the design flood can still pass safely through the culvert after the addition of retrofit changes. Though retrofitting can be an attractive alternative to doing nothing or to replacing an existing culvert with something better, safe retrofitting of an existing culvert simply is not always possible.

The introduction of artificial roughness into the lower portion of a culvert barrel increases the level of turbulence in the flow, possibly eliminating the reduced velocities in the

boundary wedge-shaped zone. Thus, artificial roughness will enhance fish passage if the resulting velocities where the fish swim in the roughened culvert are less than those where the fish swim in culverts roughened only by corrugation roughness. Unfortunately, where the dividing line lies between the effectiveness of these two types of roughness, if there is one, is not known.

IV.C.4. Culvert Roughness to Control Water Velocities

IV.C.4.a. Corrugation Roughness

Because effective boundary roughness is virtually a necessity for fish passage, it is important that culvert materials result in relatively high Manning n factors. "Hydraulic Design of Highway Culverts" (1985) tabulates Manning n values for a number of different culvert materials and corrugation configurations. From this reference, it is clear that corrugated structural steel plate pipes (SSP) should be preferred. Concrete pipes are too smooth to encourage fish passage. Spiral corrugated metal pipes have relatively small Manning n values and the writers do not recommended them for fish passage, because they are uncertain of expected water velocities where fish swim.

SSP culverts with corrugations 6 in x 2 in or 9 in x 2½ in are recommended for fish passage installations. This type of culvert is available in 60-in and larger diameters. "Hydraulic Design of Highway Culverts" (1985) lists Manning n value ranges of 0.033-0.035 and 0.033-0.037 for these two corrugation patterns respectively. Katopodis et al. (1978) report $n = 0.037$ for a 14-ft diameter culvert of this type flowing partially full at several depths, as would be necessary for fish passage.

These corrugation roughnesses appear to result in water velocities of $0.4 V_{ave}$ in the wedge-shaped swimming zone (V_{occ})—less if the tube is less than approximately $0.3 D$ full. For small diameter culverts, smaller corrugations may be required. However, the writers are not prepared to say how much V_{ave} must be reduced to allow fish passage through such culverts.

IV.C.4.b. Types 1 and 3 Depressed Invert Culverts (DIC's)

Placing fill material in the bottom of culverts is a common method of increasing their roughness. Water velocities can be reduced by use of Type-1 and Type-3 DIC's (Figures IV-9 and IV-10) if the roughness of the culvert bottom is greater than that of the side corrugations. The resulting Manning n value is a composite

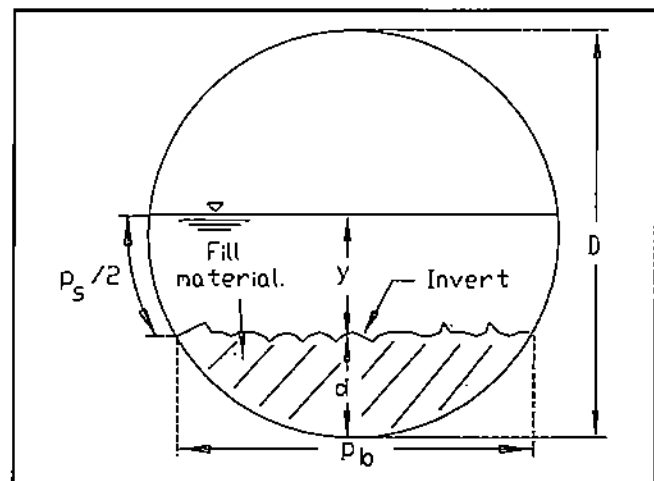

Figure IV-9. Definition of terms for depressed invert culverts (DIC's).

of the n values for the corrugation side walls and the bottom filling material. “Hydraulic Design of Highway Culverts” (1985) presents a preferred method for determining composite Manning n values when those for the individual components and the lengths of wall segment perimeter for each component is known (the design software provides for this calculation). When designing partially full culverts for fish passage, the depth of flow is not initially known, so the length of side-wall wetted perimeter is not known either. Thus, a trial-and-error solution is required to determine the normal depth for a given Q and culvert size, materials, and depth of filling. Figure IV-10 shows the pertinent parameters.

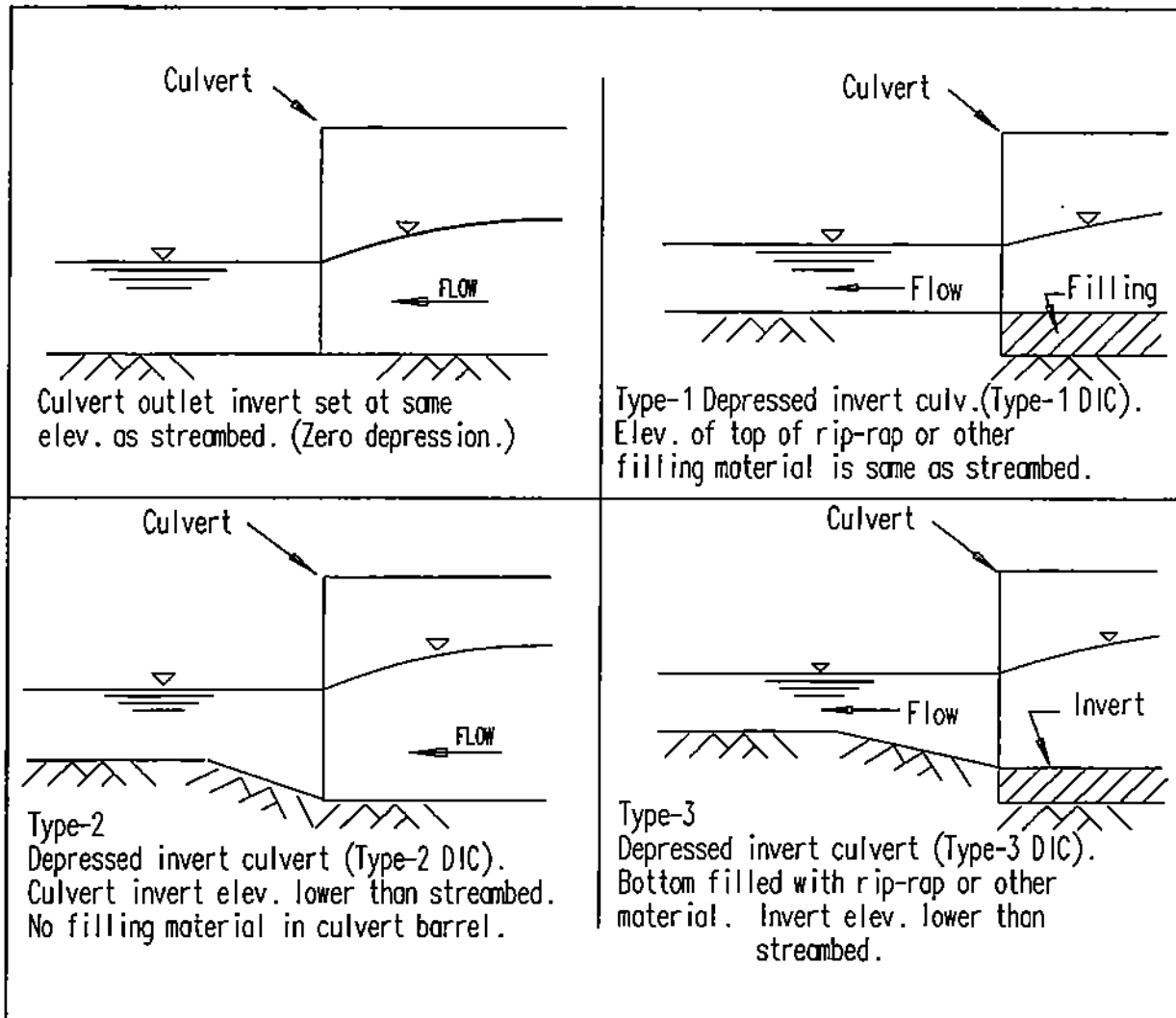

Figure IV-10. Definitions of types of depressed invert culverts (DIC's).

IV.C.4.c. Baffled Inverts

IV.C.4.c.1. Introduction

For culverts requiring slopes too great to achieve fish passage through plain culverts (circular or elliptical), artificial metal or concrete baffles can be located in culvert inverts to provide additional roughness to the invert segment of culverts. These must be spaced sufficiently close together so that fish do not have long distances to swim between the resting areas provided by such baffles. Ideally, baffles would create a slow, uniform current close to the invert through the entire length of the culvert. However, artificial roughness elements must

be placed at discrete locations and must be separated from each other by some distance.

Thus, fish do not have the slow, uniform current which would be best for them.

Because maintenance of culverts is no easy task and is only possible during very low or zero discharges, baffling systems must be relatively maintenance free. Bed material moving through the culvert should not impede fish passage by covering over the roughness baffles or by piling up at the culvert inlet. Sticks should not impair the capacity of the culvert to pass fish and large design-flood flows. Only those types of baffling which the writers are fairly confident will not present problems to fish passage or large flood flows will be discussed here, though none of these methods are absolutely maintenance free. Certainly, there are other baffle arrangements, unknown to the writers, which are effective for fish passage and safe for major flood flows.

IV.C.4.c.2. Canadian Baffle Systems

Engel (1974) reported on hydraulic model studies of artificial roughnesses introduced into culverts. These consist of: (1) block-type spoilers arranged as staggered "teeth" across the bottom of the culvert and longitudinally along the culvert axis, (2) offset baffles $0.1 D$ in height, one longitudinal series of baffles oriented normal to the culvert axis and one series arranged at a 30° angle to the oncoming flow (see Figure IV-11), and (3) a side-baffling system which isolates the fish passage channel from the remainder of the culvert.

Because of the complexity of the teeth, Canadian practice has apparently moved away from the block-type spoilers. The writers conclude that the side-baffling system is not suitable for

fish passage because of the high probability that debris would plug the side channel. The offset baffle system appears to provide good fish passage conditions with a reasonably small probability of debris problems. This system is probably not as free of debris trouble as low inlet culvert weirs which will be discussed later.

Katopodis, Lodewyk, and Rajaratnam (1987) performed a laboratory study of the baffle arrangement shown in Figure IV-11. They assumed that the fish would swim along the invert between baffles and would stop to rest behind the baffles. Their laboratory study developed several dimensionless formulae for depth of flow and water velocity where the fish were expected to swim. These were

normalized on Q and D . If a culvert diameter is greater than about 3 ft, the standard baffle system has rather large spaces ($0.6 D$) between pairs of baffles. The writers' study of that data, which included detailed isovels at various locations in the culvert, led them to believe that Class-I fish could not negotiate a culvert while swimming along the invert at any reasonable Q_f , because the distance between baffles ($0.6 D$) is too great for Class-I fish to swim continuously in the white muscle mode. (Also, no fish of this class had actually been

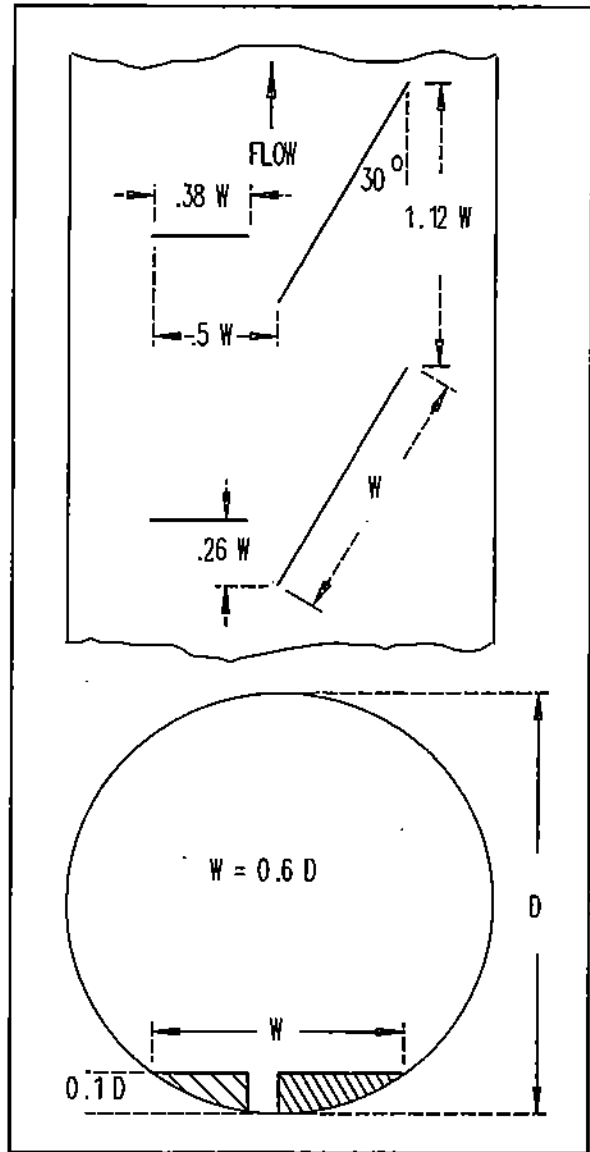

Figure IV-11. Canadian offset baffle system for culverts.

seen swimming along the invert of such baffled culverts in any flow representative of Q_f .)

Further study of the detailed velocity measurements near the water surface and next to the culvert wall, however, revealed that relatively small water velocities occur at that location.

The writers therefore believe that flow details down the center of the culvert between baffles are not pertinent to passage of weak-swimming fish, though that may be the path favored by stronger-swimming fish. Bearing this in mind, Equations 4.12 through 4.15, which follow, relate largely to offset baffle culvert design for both strong- and weak-swimming fish.

Equations 4.16 and 4.17 are useful when designing for weak-swimming fish, while Equations 4.18-4.21 relate only to strong-swimming fish.

Katopodis et al. (1987a) performed analytical and extensive hydraulic model studies of the offset baffle system. Their analysis of flow through such a system of baffles led them to select several convenient dimensionless parameters for organizing the data obtained from their hydraulic model studies. The following discussion is the writers' summary of the results of those studies.

For a given Q , culvert slope (S_o), and culvert diameter (D), a dimensionless discharge (Q_*) can be defined as follows:

$$Q_* = \frac{Q}{(g S_o D^5)^{0.5}} \quad \text{-----Eq. 4.12}$$

Since the maximum water velocities occur in the oblique slot between two adjacent, dissimilar baffles, the depth of flow there with respect to the invert is selected as a reference

depth (Y_B). Katopodis, et al. (1987a) found that a good functional relationship exists between Q_c and the dimensionless depth Y_B/D for values of Y_B/D up to 0.2. This is:

$$Q_c = 12.0 \left[\frac{Y_B}{D} \right]^{2.6}, \quad \text{-----Eq. 4.13}$$

or

$$\frac{Y_B}{D} = 0.384 (Q_c)^{0.385}. \quad \text{-----Eq. 4.14}$$

Field study data of a 14-ft diameter culvert (Katopodis et al., 1978) resulted in the following equation:

$$Q_c = 18.62 \left[\frac{Y_B}{D} \right]^{3.19}. \quad \text{-----Eq. 4.15}$$

For values of $Y_B/D < 0.2$, the model study data and the prototype data ($D = 14$ ft) plotted well together.

The writers' analysis of the Katopodis et al. (1978) 14-ft diameter culvert data revealed the following equation:

$$\frac{Y_B}{D} = 0.4 Q_c^{0.33}, \quad \text{-----Eq. 4.16}$$

for $0.11 < Y_B/D < 0.34$, which covers the range of depths likely to be used for fish passage. The isovels of that data revealed probable zones of lower water velocities near the

culvert sides close to the water surface, similar to the wedge-shaped zones previously discussed for non-baffled culverts. The writers' analysis of that information yielded the following equation:

$$\frac{V_{occ}}{V_{ave}} = \frac{0.24}{(Q^{0.5})} \quad \text{-----Eq. 4.17}$$

where V_{occ} is the water velocity in the wedge-shaped location where the writers believe *Class-I fish* are likely to swim, and V_{ave} is Q/A , where A is the cross-sectional area of flow calculated for depth Y_B , and ignoring the cross-sectional area of the baffles. Interestingly, for the range of data taken in the 14-ft diameter culvert, V_{occ} was almost constant over the range of depths $0.12 < Y_B/D < 0.42$.

The writers recommend Equations 4.12, 4.16, and 4.17 for design of the standard (baffle height = $0.1 D$) system for passage of *Class-I fish*. Thus, for a given culvert with off-set baffles, V_{occ} can be calculated and compared with the design fish's swimming capabilities to determine if a specific design is suitable for fish passage.

Concerning the passage of *strong-swimming* fish, Katopodis et al. (1987a) define a dimensionless velocity,

$$U_* = \frac{U}{(g D S_o)^{0.5}}, \quad \text{-----Eq. 4.18}$$

where U is the maximum water velocity attained vertically above the slot between baffles (where strong-swimming fish might swim). From the model test data, they found the following functional relationship between U_* and Y_B/D :

$$U_* = 12.8 \left[\frac{Y_B}{D} \right]. \quad \text{-----Eq. 4.19}$$

Analysis of slot velocity distributions in the models yielded an approximate dimensionless velocity equation:

$$\frac{u}{U} = 0.93 \left[\frac{y}{h} \right]^{0.18}, \quad \text{-----Eq. 4.20}$$

where u is the water velocity at a vertical distance y above the invert in the slot, and h is the baffle height, which is $0.1 D$ for a standard baffle system.

Equations 4.12 and 4.18-4.20 can be rearranged and combined to yield a potentially useful design equation for standard baffles for passage of *strong-swimming* fish:

$$D = 20.4 (u)^{-1.56} Q^{0.6} (g S_o)^{0.484} y^{0.281}. \quad \text{-----Eq. 4.21}$$

In order to use Equation 4.21 to obtain a suitable D for given fish size and swimming capabilities, u would be the water velocity where the fish is assumed to swim (next to the invert), and y would be the vertical height of the design fish (about $L/4$). However, since fish must move ahead while being subjected to water velocity u , the design u must be equal to the acceptable short-term V_{fw} minus the forward velocity of the fish (V_f), that is, $u = V_{fw} - V_f$. So if strong fish swimming in the white muscle mode are expected to progress in the

high velocity zone at a $V_f = 5$ ft/sec, and their V_{fw} is 10 ft/sec, u must be no greater than 5 ft/sec. For *this* swimming route, if S_o is greater than approximately 0.04, gradient forces require that allowable water velocities be reduced to accommodate profile drag and gradient forces while not overstressing the fish. As stated previously, the writers do not believe Class-I fish could swim long enough in the white muscle mode to get from baffle to baffle using the route along the culvert invert. Therefore, the methods of this paragraph are not intended to be used for passage of weak-swimming fish.

Using a 14-ft diameter model with standard offset baffles, Katopodis et al. (1978) found that the Manning n value decreased from $n = 0.139$ for $Y_b/D = 0.17$ to $n = 0.047$ for $Y_b/D = 0.53$. The Manning n value for an identical unbaffled control culvert with 2 in x 6 in corrugations was 0.037. The magnitude of the flood studied did not provide enough discharge for gathering data at depths greater than $0.53 D$. However, the data for depths up to $Y_b/D = 0.53$ appeared to indicate a leveling of the Manning n value at $n = 0.047$. It is likely that the n value would decrease somewhat with increasing depth beyond the maximum for which they were able to obtain data. What the n value would be for greater relative depths is not known. When designing culverts conservatively for design-flood flows where it is desired to have the culvert flow at relative depths (Y_b/D) greater than 0.53, it appears a Manning n value for standard offset baffles could be assumed to be $n = 0.047$.

If a Manning n of 0.047 is used, a baffled culvert should be analyzed as a standard culvert or as a Type-2 depressed invert culvert (Figure IV-10), depending on the situation. The

presence of baffles does not create Type-1 or Type-3 DIC conditions. Note that if a baffled culvert is a Type-2 DIC or if backwater from downstream creates depths in the culvert greater than y_n , water velocities through the baffle slots would be less than those predicted by Equation 4.18. The depth of flow at any location in the culvert would then be determined from backwater computations instead of by means of Equation 4.14. Since the normal depth of flow (y_n) for a baffled culvert is greater than that for an unbaffled culvert of similar geometry, slope, and discharge, outlet conditions must be considered carefully to avoid a large drop in the water surface (and HGL) at that point.

Katopodis et al. (1987a) also studied hydraulic model double-height offset baffles. Doubling the value of h/D to 0.2 without changing the spacing of the baffles in the culvert decreased water velocities considerably in the slot between two baffles of a set as compared to those obtained in the slot of a standard set of baffles ($h/D = 0.1$). For the double-height baffles:

$$Q_* = 11.14 \left[\frac{Y_B}{D} \right]^{3.63} \quad \text{-----Eq. 4.22}$$

The writers' analysis of the Katopodis et al. (1987a) data yields the following relationship between U_* and Y_B/D for double-height baffles:

$$Q_* = \frac{U}{(g S_o D)^{0.5}} = 5.67 \left[\frac{Y_B}{D} \right], \quad \text{-----Eq. 4.23}$$

for $Y_B/D > 0.25$. There is insufficient data to provide an equation for $Y_B/D < 0.25$.

Katopodis et al. (1987a) did not present a relationship between u/U and y/h for the double-height baffles, and the writers have not developed such a relationship. However, comparison of Equations 4.23 and 4.19 shows that for the same values of S_o , D , and Y_B the double-height baffles produce a U which is slightly less than half that for a standard baffle installation. Thus, the jet velocities in the slot between paired double-height baffles may be approximately half those for the standard baffle. Since the double-height baffles are $0.2 D$ in height, they may present a debris accumulation problem greater than that of the standard-height baffles.

Katopodis et al. (1987a) also performed hydraulic model studies of standard-size baffles ($h = 0.1 D$) with half spacing ($0.3 D$). For these studies the equation for the Q_u versus Y_B is:

$$Q_u = 9.38 \left[\frac{Y_B}{D} \right]^{2.62} \quad \text{-----Eq. 4.24}$$

A plot of this equation lies approximately halfway between that of Q_u versus Y_B/D for the standard baffles and that for the double-height, standard-spaced baffles. The writers' analysis of the Katopodis et al. (1987a) data for the standard-size baffles spaced at one-half the standard spacing yielded the following equation for U_u :

$$U_u = 10.8 \left[\frac{Y_B}{D} \right] \quad \text{-----Eq. 4.25}$$

Again, those investigators did not provide an equation relating u/U and y/h , and the writers have not found a relationship between these two variables. The half-spaced, standard baffle arrangement is attractive for reducing water velocities and for reducing the distance between "resting places" in large diameter installations. However, because of a lack of data, the velocity distribution in the slot between baffles and wedge zone velocities are unknown.

Katopodis et al. (1987a) also studied another, longer spacing of standard baffles, but they concluded that the resulting hydraulics would not be good for fish passage. They also studied rectangular teeth, which they called spoilers, in a 14-ft diameter culvert in parallel to those already discussed. Though these spoilers did exhibit good hydraulic characteristics, they appeared to show no advantages over the baffles, and they were considerably more complicated to fabricate and install in a culvert.

It appears the Canadian researchers responsible for the development of offset baffle systems expect the fish to swim at the invert of the culvert. The writers' review of the Katopodis et al. (1978) velocity profiles taken in 14-ft diameter culverts and their field observations leads them to believe that when conditions are difficult, Class-I fish swim in the wedge-shaped zone near the edges of the water surface even in the baffled system. The Katopodis et al. (1978) cross section velocity profiles for standard baffles (baffle height = $0.1 D$) clearly reveal that conditions for fish passage appear better in the wedge-shaped zone than at the invert. Fish swimming in the *red muscle* mode in this zone can drop down to rest behind baffles. The writers have not found references to any field studies which have addressed where the fish swim in baffled culverts. This would be an appropriate area for future studies.

IV.C.4.c.3. Summary of the Use of Offset Baffles

Standard baffles can probably be used in culverts of any diameter to substantially reduce water velocities in culverts having slopes as great as 5%. For a given culvert slope and length, the diameter of culvert usually depends on fish passage requirements rather than design flood requirements. Half-spaced baffles are suggested for culverts larger than 10 ft in diameter, because resting points are not so far apart as would be the case in a large-diameter culvert with standard baffles. However, half-spaced baffles show considerable promise for passage of strong and weak-swimming fish. At present (1990), hydraulic details of the flow in such baffled systems are not sufficient to allow design with high certainty of success. Therefore, they should only be tried on high-slope systems where other better-known options cannot perform the task.

The most prolific hydraulic modelling research pertaining to the hydraulics of fish passage facilities, especially culverts, has been performed by N. Rajaratnam and C. Katopodis at the University of Alberta, Edmonton. These researchers are continuing to investigate the problem of fish passage through culverts. Fish passage design engineers should certainly be aware of the continuing efforts of this group.

IV.C.4.d. Weir-Type Baffles for Steep Culverts

A series of cross-channel, weir-type baffles can be an effective device for making fish passage possible in relatively steep culverts. Fish must negotiate the velocity of flow over the weir and the weir step height. These difficulties limit the discharge which these devices can pass while allowing for fish passage upstream. Weir baffles in culverts provide stepped

pools with areas of reduced water velocity where fish can rest and swim easily from weir to weir (Figure IV-12). However, since fish must lift themselves over each weir nappe from the lower pool to the upper pool, they must switch their swimming muscle mode from red muscle to white muscle and back again at each weir. If the weir nappe is ventilated (i.e., plunging water springs clear of the weir plate and the water), ∇p is zero in the plunging water. Thus, fish lose buoyancy as they move up through the falling jet, so a

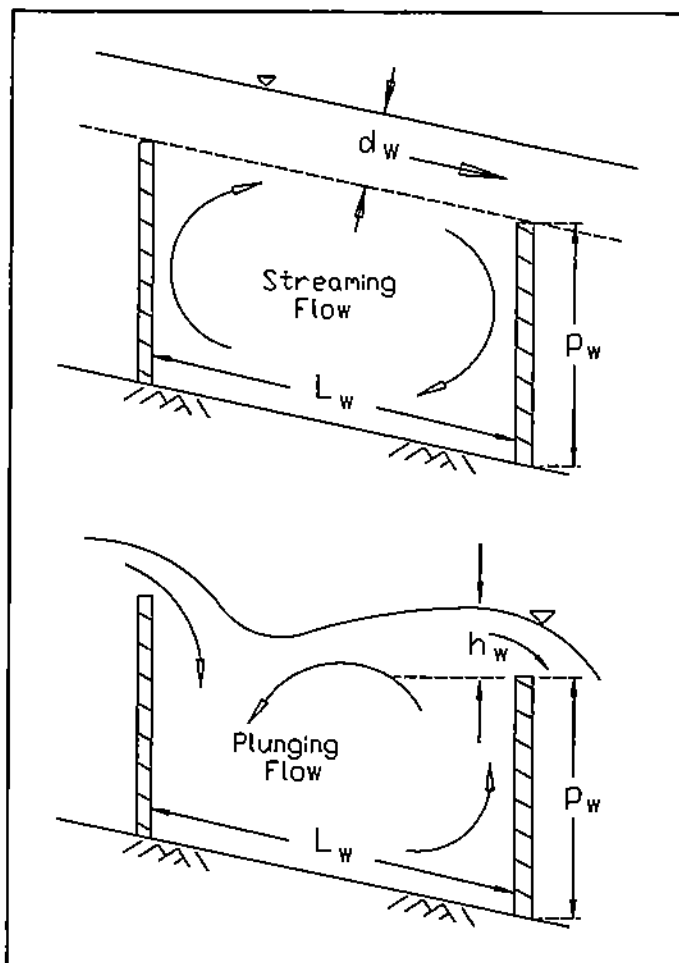

Figure IV-12. Streaming and plunging flows in pool-and-weir baffle arrangements for fish passage in culverts.

ventilated, plunging nappe is more difficult than if the weir nappe “floats” on the receiving pool’s water surface. Except in cases where weir plates are very thin, the weir nappe is seldom ventilated.

Under low flow conditions, flow over a weir may plunge deeply into the receiving pool. With greater discharges the flow may stream over the weir and across the upper part of the receiving pool on its way to the next downstream weir. It is more difficult for fish to pass over the weir if the plunge is high. Streaming flow would appear to be the ideal situation for

fish, because it minimizes the gradient force on them, but the velocity of flow over the weir can be too difficult for fish to negotiate. Streaming flow designs at flow Q_f allows for the use of smaller diameter culverts than do plunging flow designs. As flow decreases from Q_f , streaming flow can change to plunging flow in a given installation. However, if vertical steps are not set too high, this causes little difficulty for fish at lower flows.

In essence, this type of culvert baffling provides a pool-and-weir fishway through a culvert. However, the situation is more complicated than in a normal pool-and-weir fishway. A culvert designed for fish passage must also carry flows of design flood magnitudes whereas the normal pool-and-weir fishway carries only the reduced flows suitable for fish passage. Also, normal pool-and-weir fishways often have openings toward the bottom and at the edge of the weir. Because orifices in weirs for culvert fishways would soon become clogged with debris, they are not suggested.

Katopodis and Rajaratnam (1989) have made an extensive laboratory study of weir baffles in culvert fishways (Figure IV-13). They selected weir heights (p_w) of $0.15 D$ and $0.1 D$ each with spacings of $0.6 D$ and $1.2 D$. Specific slopes studied were 1, 3, and 5 percent.

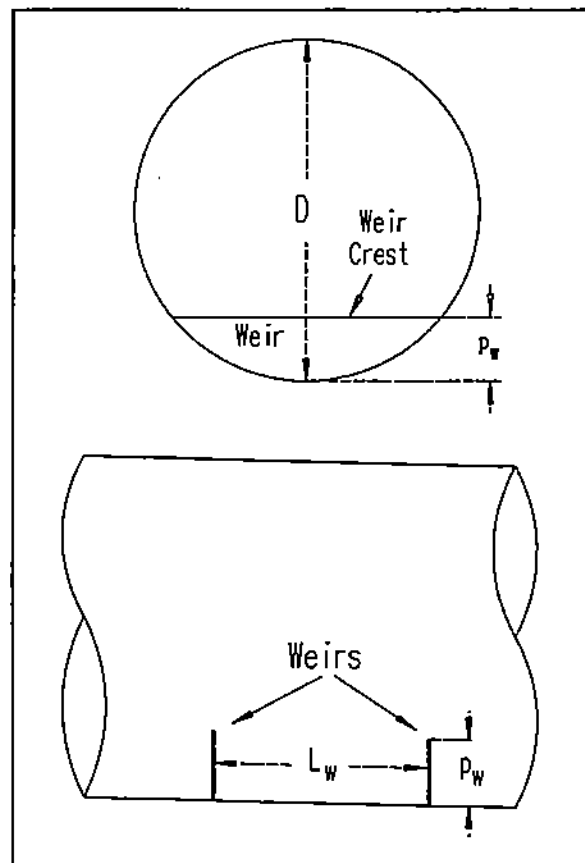

Figure IV-13. Definition of geometric terms for weir baffles in culvert.

To simplify the discussion, the four weir height-spacing designs will be labelled as follows:

Design	p_w	L_w
D1	0.15 D	0.6 D
D2	0.15 D	1.2 D
D3	0.10 D	0.6 D
D4	0.10 D	1.2 D

The studies defined two depths of flow: (1) Y_a , the depth of flow halfway between adjacent weirs, and (2) Y_p , the depth of flow immediately upstream from a weir. Since the obvious location of difficulty for fish is at the weir, Y_p is the depth most important to fish passage.

The study report did not attempt to derive equations relating Y_p to the other pertinent parameters of the study. The writers have, however, derived equations from the 1989 data which relate Y_p/D to Q_* (defined by Equation 4.18) for each of the four configurations.

These follow:

For design D1 and $0.15 < \frac{Y_p}{D} < 0.4$,

$$\frac{Y_p}{D} = 0.41 (Q_*)^{0.202} \quad \text{-----Eq. 4.26}$$

For design D2 and $0.15 < \frac{Y_p}{D} < 0.4$,

$$\frac{Y_p}{D} = 0.46 (Q_*)^{0.25} \quad \text{-----Eq. 4.27}$$

For design D3 with $0.1 < \frac{Y_p}{D} < 0.4$,

$$\frac{Y_p}{D} = 0.35 (Q_*)^{0.23} \quad (\text{for } Q_* < 0.2), \text{ and} \quad \text{-----Eq. 4.28a}$$

$$\frac{Y_p}{D} = 0.44 (Q_*)^{0.44} \quad (\text{for } Q_* > 0.2). \quad \text{-----Eq. 4.28b}$$

For design D4 with $0.1 < \frac{Y_p}{D} < 0.4$,

$$\frac{Y_p}{D} = 0.40 (Q_*)^{0.32}. \quad \text{-----Eq. 4.29}$$

Since Q_* is usually much less than design-flood flows, the above equations should adequately cover the range of flows and depths of potential use for fish passage.

Katopodis and Rajaratnam (1989) also studied the velocity distribution for flow at the weir crest. At the center of the culvert, the water velocity varied with distance above the weir crest, generally increasing to a maximum and then decreasing somewhat with further distance from the weir crest until the water surface was reached. They defined a dimensionless water velocity,

$$U_* = \frac{U}{(g S_o D)^{0.5}}, \quad \text{-----Eq. 4.30}$$

where U is the maximum water velocity above the weir crest at the center of the culvert.

Because the writers' analysis of the Katopodis and Rajaratnam (1989) data indicated that designs *D1* and *D3* (those with a baffle spacing of $0.6 D$) yielded better passage possibilities for weak-swimming fish, the following discussion relates only to designs *D1* and *D3*.

For design *D1*, Y_p is related to Q_* as follows:

$$\frac{Y_p}{D} = 0.41 (Q_*)^{0.202} \quad (\text{for } Q_* < 0.4), \text{ and} \quad \text{-----Eq. 4.31a}$$

$$\frac{Y_p}{D} = 0.5 (Q_*)^{0.25} \quad (\text{for } Q_* \geq 0.4). \quad \text{-----Eq. 4.31b}$$

and U_* is related to Q_* as follows:

$$U_* = 2.92 (Q_*)^{0.17} \quad (\text{for } 0.15 < \frac{Y_p}{D} < 0.25), \text{ and} \quad \text{-----Eq. 4.32a}$$

$$U_* = 4.3 (Q_*)^{0.41} \quad (\text{for } \frac{Y_p}{D} \geq 0.25). \quad \text{-----Eq. 4.32b}$$

For design *D3*, Y_p is related to Q_* as follows:

$$\frac{Y_p}{D} = 0.46 (Q_*)^{0.25}, \quad \text{-----Eq. 4.33}$$

and U_* is related to Q_* as follows:

$$U_* = 3.7 (Q_*)^{0.24} \quad (\text{for } 0.1 < \frac{Y_p}{D} < 0.35), \text{ and} \quad \text{-----Eq. 4.34a}$$

$$U_* = 4.21 (Q_*)^{0.38} \quad (\text{for } \frac{Y_p}{D} \geq 0.35). \quad \text{-----Eq. 4.34b}$$

The data also indicated a cross-channel velocity distribution at the weir crest, with the smallest velocities at the boundary between the weir crest and the culvert wall. The writers' evaluation of those data for the zone just above the weir crest, close to the culvert wall, where *Class I* fish are expected to swim when passing over each successive weir, indicated that for design *D1*

$$V_{occ} = 0.6 U_* (g S_o D)^{0.5}, \quad \text{-----Eq. 4.35}$$

and for design *D3*

$$V_{occ} = 0.8 U_* (g S_o D)^{0.5}. \quad \text{-----Eq. 4.36}$$

Since fish must deliver an elevated power output while swimming over each weir baffle, the writers assume grayling would move with a velocity of 1 ft/sec with respect to the weir (V_f).

Since $V_{fv} = |V_f| + |V_{occ}|$, and the slope of the hydraulic grade line (HGL) is equal to the slope of the culvert, power required for a swimming fish to pass over each weir can be calculated for a specific Q_f , D , and S_o . The writers expect that 240-mm Class-I fish safely deliver at least 4 watts of power for a very short time period to clear each weir baffle.

When fish passage is the determining factor in culvert sizing, proper design briefly stresses this design fish to the 4-watt level at each weir baffle.

Strong-swimming fish would probably swim over weir baffles where the water velocity is defined by U in Equation 4.30 for a specific value of U_c . Certainly, that water velocity for V_{occ} for large, strong fish is quite conservative.

Any obstruction, such as weir baffles, inside a culvert generates the potential for accumulation of debris and sediment. This accumulation may diminish the culvert's carrying capacity and interfere with fish passage. The turbulence created between adjacent baffles by streaming flow is considerable. The writers anticipate that during flood flows much of the bedload previously accumulated between weirs would be washed out. Some accumulation would exist continuously between adjacent weirs, but the writers do not expect this to have noticeable effect on fish passage. This type of weir is relatively "clean" to the flow because it does not contain sharp edges or V's which tend to trap organic materials. Thus, this type of rather low weir should be relatively self-cleaning.

Design $D1$ has better energy dissipation characteristics than design $D3$, so for a given D and Q_f , design $D1$ is more effective for fish passage at greater slopes than is design $D3$. Design $D3$ consists of lower weirs than those of design $D1$. Thus, design $D3$ is favored wherever it is capable of supporting fish passage, because it has less potential for debris accumulation.

Unfortunately, Katopodis and Rajaratnam (1989) did not study the effects of weir baffles on full flow friction characteristics, so it is not possible to determine the flow characteristics for depths greater than approximately $0.9 D$. Since the culvert diameter will usually be determined by Q_f , this lack of information will seldom be important, because the culvert will

probably be oversized for design flood discharge and will not fill for that discharge.

However, the writers' analysis of the 1989 data indicates the following relationships:

For weir-baffle height = 0.15 D ,

$$\frac{\Delta y}{y_n} = 0.75 Q_*^{-0.42}, \quad \text{-----Eq. 4.37}$$

and for weir-baffle height = 0.1 D ,

$$\frac{\Delta y}{y_n} = 0.57 Q_*^{-0.48}, \quad \text{-----Eq. 4.38}$$

where Δy is the *increase* in water depth in the culvert due to the presence of weir baffles, and y_n is the normal depth for the same culvert parameters in the absence of weir baffles.

In the design process for weir-baffled culverts, since fish passage flow must be accommodated, it should be designed for first. When a satisfactory design has been found for fish passage discharge (Q_f), the normal depth of flow (Y_n) should be determined for the design-flood flow. This normal depth is then increased according to Equation 4.37 or 4.38, as appropriate, to determine the expected flow depth in the culvert for design-flood flow. If this depth is greater than 0.9 D , a larger culvert diameter must be tried.

IV.C.5. Settlement of Pool-and-Weir Fishway Culverts

The writers have observed the inside of many culverts in Alaska. They have found that several have settled and deformed due to the stress of the road fill, freeze and thaw effects, and whatever else. Especially at low flow rates, excessive drop may occur in successive

pools. It is important to understand how to remedy these effects on weir-and-pool fishways which create a local steepening of the culvert slope. Intermediate weir baffles can be added to alleviate this problem, but such additions have hydraulic consequences which must be considered. Figure IV-14(a) illustrates a segment of a culvert with a short, steep segment just downstream from its inlet. Figure IV-14(b) illustrates a solution to a culvert settlement problem at the inlet end of the culvert.

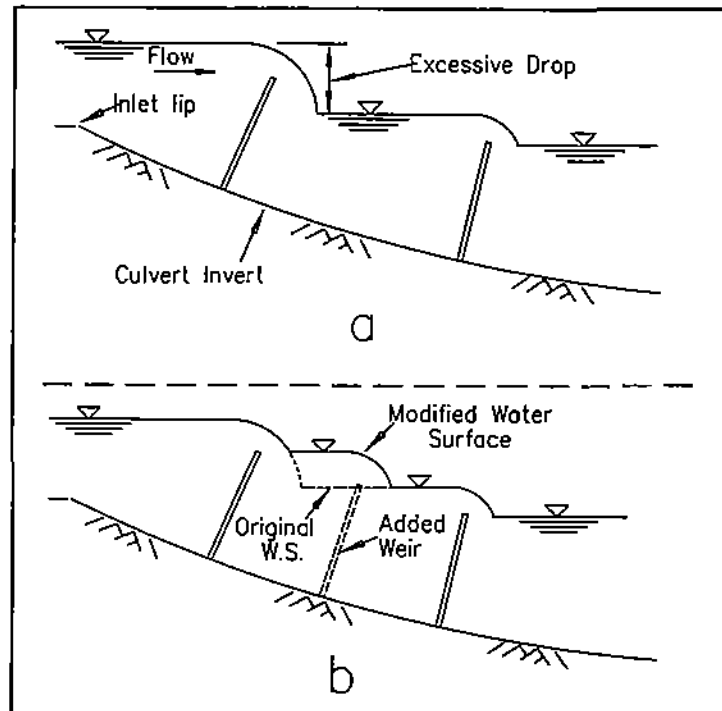

Figure IV-14. (a) Culvert settlement has created excessive drop in water surface elevation between weirs. (b) Intermediate weir added to restore design drop, or less, between pools.

IV.C.6. DOT&PF Rebar Weirs

The Alaska Department of Transportation and Public Facilities (DOT&PF) has begun to construct stepped weirs by placing single, 1-in diameter, horizontal rebars transverse to the culvert axis at a height of 1 ft from the culvert invert. This method was used at Bearing Tree Creek, Alaska Highway Milepost 1273.05. At this location, the culvert is 6 ft in diameter, and the rebars are spaced 25 ft apart along the axis of the culvert. The rebars were simply cut long and their ends inserted in holes drilled in the sides of the culvert.

Individual rebars trap floating sticks between the rebar and the culvert bottom. In due course, enough debris is trapped to form a cross-channel weir of the type previously discussed. (Here $p_w/D = 0.17$, which is slightly greater than the Katopodis and Rajaratnam (1989) weir baffles.) This type of installation requires maintenance because large stumps and other debris can become caught between the rebar and the culvert bottom. However, after 5 years, few large sticks extend above the rebar weir crests. The spacing between rebars in the longitudinal direction (L_w) is quite long. Since the culvert has settled somewhat, additional bars should be located toward the inlet end of the culvert to reduce the plunging drop distance at that end. However, such additions are relatively easy to make at this site and at others where the culvert diameter is sufficient to allow entrance of workers and limited equipment.

Observations of this culvert reveal that the installation appears to be working well except where settlement has occurred. However, because of the circular shape of the culvert, the flow in the steep settlement segment near the inlet constricts, after plunging over the weirs, to a very narrow flow along the bottom of the culvert. This results in excessive velocities and presents little opportunity for fish to approach the farthest upstream weirs during low flows. This rapid velocity effect is much more pronounced than it would be in a rectangular culvert of the same relatively steep slope. Additional transverse rebars are needed in this segment of the culvert. Figure IV-15 indicates the much reduced cross-sectional area of flow downstream from the weir as opposed to the larger cross-sectional area of flow upstream from the weir.

This installation has not been observed at higher flows, so it is not known how it would work for a design flood, but the weirs should not be too constrictive for relatively large flows. The writers observed this installation functioning with about 4 cfs of flow. It performed very well hydraulically, except in the steep zone near the inlet. At this discharge, where the weirs were functioning properly, the drop in

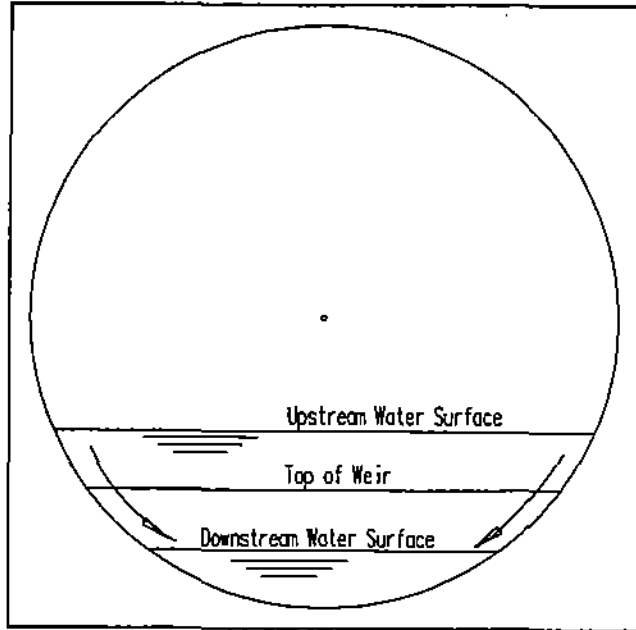

Figure IV-15. Effect of excessive water surface drop between rebar weirs.

water surface elevation was approximately 0.25 ft/weir. Unfortunately, observations were not made when fish were attempting to pass through this culvert.

Clearly, this is a very inexpensive type of installation, so the question arises: Why use solid baffles at all? The reason is that solid weir plate baffles provide fewer possibilities for larger sticks and stumps to distort the flow over weirs. They also ensure that the weir functions immediately, without waiting for a stick barrier to form. The solid weir plates are simply more reliable. The writers do not recommend installing single transverse rebars higher than 1.5 ft above culvert inverts because of the potential for gathering large logs and stumps which could deform the weir flow. Piping via the rebar holes in the culvert sides is a potential problem if the holes are too large. It was not possible to determine if piping was occurring at this installation.

IV.C.7. Discrete Rip-rap Roughness

DOT&PF and the Alaska Department of Fish and Game (ADF&G) designed and installed a retrofit roughness for one of the Darling Creek culverts, at approximately Milepost 19.5 on the Nome-Taylor Highway. There are two parallel culverts of the same diameter at this location; only one has been retrofitted. The retrofit culvert is set with its invert 1 ft lower than the natural stream channel thalweg while the other culvert is set at the natural stream elevation.

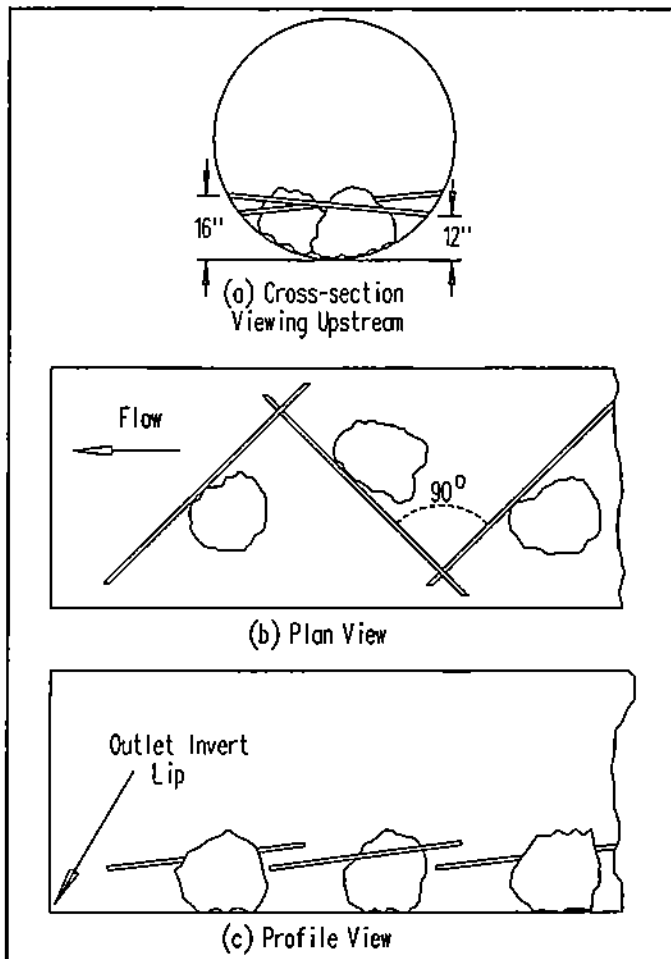

Figure IV-16. Rebar and boulder arrangement to reduce water velocities and provide resting locations for fish.

The retrofit consists of alternately-directed, diagonal 5/8-in rebar set into holes in the side of a 5-ft diameter SSP culvert (Figure IV-16). Large (18-in) discrete boulders are located in the V created by the intersection of the downstream end of each diagonal bar with the side of the culvert. Only one of these large boulders is located at each V, and they are held in place by their weight and by the wedging action of the culvert wall and the individual rebar.

Each rebar has a cross-channel slope. The upstream end of the rebar is set 16 in higher than the elevation of the culvert invert at that location and the downstream end of the rebar is set

12 in above the invert elevation at that location in the culvert. The fish passage design discharge for this pair of culverts is 54 cfs and the design flood is 165 cfs. Thus far, it is not known if fish passage actually occurs during Q_f . To date, fish passage has been successful.

This retrofit was installed in 1987. Until 1989 it required minimal maintenance.

Unfortunately, the installed rebars were only 5/8-in diameter, and they did not withstand the spring floods of 1989. It appears that 1-in rebar would have performed properly. How this system would perform where there is larger organic debris is not yet known. However, it can be expected that the rebars will create cross-channel diagonal weirs as they intercept debris.

The arrangement of rebars and strategically located boulders creates a zigzag flow pattern down the culvert. The lee side of the boulders also provides a rest zone for the fish where they can remain for as long as they desire before moving upstream. Because the culvert diameter is relatively small and the size of the boulders is large in relation to the culvert size, the distance which fish must swim between the protective areas created by the boulders is small.

This apparent solution to some fish passage problems has not been proven as a favored solution for a wide range of slopes, flows, and culvert diameters. At this point, it might be attempted where fish passage is presently very difficult or impossible. Not enough is presently known about this type of roughness to translate it to a Manning roughness factor.

To avoid creating outlet problems, this technique should be implemented together with culvert depression below the stream bottom.

IV.C.8. Culvert Bedload Collectors

A very inexpensive in-culvert bedload collector has been developed and used in Montana for several years (Clancy and Reichmuth, 1990). Initially designed by D.R. Reichmuth, the purpose of this device is to collect and stabilize sufficient bedload material in the culvert invert to effectively create an artificial type-1 DIC from a new or existing culvert. It consists of

a frame which resembles a long step-ladder the length of the culvert and which is wide enough to support itself approximately 1 ft off the culvert invert (Figure IV-17). Rebar loops, welded to the frame cross members, extend down from the cross members to slightly above the culvert invert. These hold large hand-placed "seed" boulders in place, and normal bedload movement fills the culvert to approximately the level of the frame. The longitudinal members of the frame are constructed of 1 1/2 in x 2 in x 1/4 in steel angle material, and the cross members are constructed of 1 in x 1 in x 1/4 in steel angle material. The cross

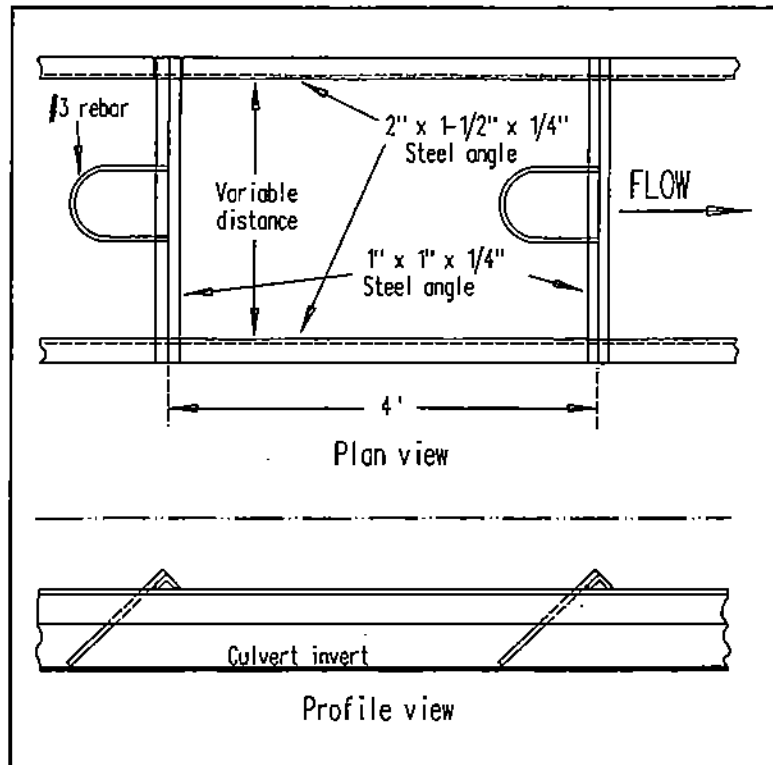

Figure IV-17. Montana bedload connector. "Ladder" is fabricated in 20-foot sections and bolted together when placed in culvert. Cross #3-members and rebar loops are welded to side members.

members are spaced 4 ft apart connecting the longitudinal members on either side of the culvert. The width of the frame varies depending on culvert diameter, in order to have the frame ride approximately 1 ft above the culvert invert. In a larger diameter culvert, two or more parallel rebar retainer loops can be welded to each cross member to ensure retention of the "seed" boulders.

The frame is prefabricated in manageable lengths and is bolted together at the culvert site. In Montana the frames are bolted to the culvert headwall at the inlet end of the culvert. A heavy horizontal transverse bar, set at frame level, is welded to the frame at the culvert outlet end. Thus, with a little work, the frame can be loosened and pulled downstream out of the culvert with the proper equipment.

In one 6.2-ft diameter culvert set at a 4.4 percent slope, this device has affected passage of Yellowstone cutthroat trout (Clancy and Reichmuth, 1990). The depth of flow in the culvert prior to installation of this device is not reported, but it appears it was less than 1 ft, and fish had been unable to negotiate the culvert. After installation, the depth of flow was still shallow, and water velocities did not appear to be appreciably reduced. However, fish could find resting places among the collected boulders. This installation has been passing fish for eight years. Unfortunately, the upper limits of flow for which it functions properly have not been documented.

This type of fish passage device has been used quite successfully for many years in culverts in Montana. Where this device has been used it appears the Q_f 's are much less than the

culvert design flow. It apparently has not been tested for fish passage under conditions of large slope with significant depths of flow (i.e., $y > 1$ ft.).

Where this type of fish passage device has been installed as a retrofit in an existing culvert, the streambed upstream from the culvert has accommodated itself to the new water surface elevation in the culvert. However, at the outlet, it has been necessary to provide an outlet pool control device to prevent the culvert from becoming perched.

IV.D. Culvert Inlet

IV.D.1. Inlet Hydraulics

The hydraulic effects of a culvert inlet consist of three elements: (1) a contraction zone for water entering the culvert from the inlet pool, (2) an expansion zone for the water leaving the contraction zone, and (3) a possible velocity effect in the culvert barrel as a result of entrance velocity skew as the water enters the culvert. These will be discussed individually though the contraction and expansion effects are closely related.

Usually, the stream approaching a culvert inlet has a greater cross-sectional area of flow than that of the culvert, so the water velocity in the culvert is greater than that of the approaching stream. The entering water increases its kinetic energy as it moves into the culvert. This increase is obtained at the expense of potential energy as the water surface drops from the inlet pool to the culvert barrel. The magnitude of the velocity increase is not only a function of the reduced cross-sectional area of flow, but it is also a function of how the water approaches the culvert inlet.

If streamlines for some of the flow entering a culvert are bent significantly at the entrance, a considerable horizontal entrance contraction may occur just inside the culvert. All of the water entering the culvert is forced to pass through a much narrower flow cross section than exists farther downstream in the culvert barrel. This is illustrated in Figure IV-18. As a result of the entrance contraction, the water's kinetic energy as it passes through this section may be significantly greater than the average kinetic energy of water flowing farther downstream in

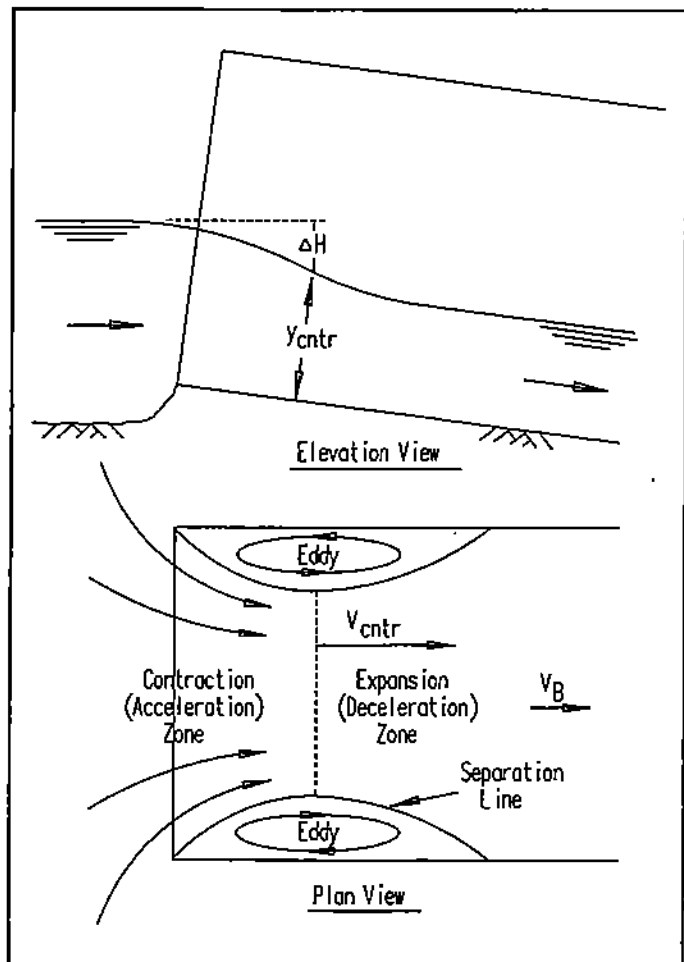

Figure IV-18. Details of flow in culvert inlet zone.

the barrel. If a culvert projects into an inlet pool which is at least twice as wide as the culvert diameter, the flow area at the contracted section in the culvert is approximately three-quarters that of the flow cross section downstream in the barrel. On the other hand, if there is an entrance headwall, the horizontal entrance contraction is not so great. If the culvert entrance is bevelled, the horizontal contraction is almost eliminated. This type of contraction is similar to the contraction which exists in pipe flow where the pipe receives water from a large tank or reservoir. It is commonly referred to as an entrance contraction, and, as in

pipe flow, it can be reduced by eliminating or reducing sharp streamline curvature at the culvert inlet.

The inlet contraction zone, which results from a need to increase water velocity on entrance to the culvert and from horizontal cross-sectional area contraction, is usually quite short. It is the writers' experience that this zone usually occurs over a distance of only a few feet, depending on culvert size.

At the end of the inlet contraction zone, the streamlines begin to diverge to utilize the full width of the culvert. If the inlet contraction has been large, the deceleration is considerable, and the deceleration zone may persist for several culvert diameters downstream until culvert friction becomes the dominant influence.

As water moves downstream from the inlet contraction zone, water velocity reduces to that in the barrel, and kinetic energy is lost. The greater the kinetic energy of water at the end of the contraction (acceleration) zone, the greater the subsequent loss must be. The loss must come principally at the expense of potential energy which the water possessed when in the culvert inlet pool. Hence, in passing through the total inlet zone (contraction plus expansion), potential energy is decreased in order to: (1) increase kinetic energy to the point of maximum contraction, and (2) feed the kinetic energy loss which results from the inlet contraction and subsequent expansion. This is manifested in a sloping water surface at the culvert inlet. Neglecting inlet pool velocity head, the slope increases as the square of the water velocity at the contracted cross section. Headwater depth, of course, must provide the potential energy to meet these requirements.

It is important to calculate the approximate velocity of flow in the contracted section.

Unfortunately, the literature does not reference laboratory or prototype studies which do so.

The following discussion attempts to obtain approximate values for this velocity of flow.

An inlet loss coefficient (K_e) is defined by its use in the head loss equation:

$$h_L = \frac{K_e (V_B)^2}{2g}, \quad \text{-----Eq. 4.39}$$

where h_L is the head loss due to the entrance contraction and V_B is the average cross-sectional velocity of flow in the barrel approximately one culvert diameter downstream from the inlet. Since the contraction zone (Figure IV-18) is one of fluid acceleration, the hydraulic losses in this zone are much smaller than those in the deceleration zone, so they may be ignored. The inlet head loss then essentially consists of some kinetic energy loss between the point of maximum contraction and the end of the expansion zone (though that kinetic energy was generated at the expense of potential energy in the inlet pool). That is:

$$h_L = \frac{V_{cur}^2}{2g} - \frac{V_B^2}{2g}, \quad \text{-----Eq. 4.40}$$

where V_{cur} is the average velocity of flow in the contracted section. Combining Equations 4.39 and 4.40,

$$\frac{V_{cur}^2}{2g} = \frac{(1 + K_e) V_B^2}{2g}. \quad \text{-----Eq. 4.41}$$

Ignoring friction losses between the inlet pool and the contracted section, the energy equation can be written for the area between a point in the inlet pool close to the culvert and the section of maximum contraction.

$$\frac{(V_{ctr})^2}{2g} = (V_{pool})^2 + \Delta H, \quad \text{-----Eq. 4.42}$$

where ΔH is the drop in water surface elevation from inlet pool to the contracted section (Figure IV-18).

If the velocity head in the inlet pool is negligible (it usually is quite small), Equations 4.41 and 4.42 can be combined to yield

$$\begin{aligned} \Delta H &= \frac{(V_{ctr})^2}{2g} \\ &= \frac{(1 + K_e) V_B^2}{2g}. \end{aligned} \quad \text{-----Eq. 4.43}$$

“Hydraulic Design of Highway Culverts” (1985) provides a listing of values for K_e , which it states are for outlet control with full and partial full inlet flows. These range from $K_e = 0.2$ for slope-tapered, corrugated metal inlets to $K_e = 0.9$ for corrugated metal inlets projecting from the embankment fill. Headwalls on corrugated metal culverts yield $K_e = 0.5$. This can be improved to $K_e = 0.2$ by bevelling the headwall.

Table IV-2 clearly reveals that if water velocities in the culvert barrel immediately downstream from the inlet zone are less than 3 ft/sec, the type of inlet has little effect on the

water surface drop from the inlet pool to contracted section. However, as design barrel velocities increase, the water surface drop quickly increases, because it is a function of the square of the velocity in the contracted section. Table IV-2 indicates the advantage of using culvert inlets with small entrance loss coefficients (K_e).

Table IV-2. Velocity head in the contracted inlet zone and difference in water surface elevation from the inlet pool to the contracted section.

V_B (ft/sec)	K_e	$\frac{V_{ctr}^2}{2g}$ (ft) and ΔH (ft)
1.0	0.2	0.02
3.0	0.2	0.17
5.0	0.2	0.47
7.0	0.2	0.92
1.0	0.5	0.02
3.0	0.5	0.21
5.0	0.5	0.58
7.0	0.5	1.13
1.0	0.9	0.03
3.0	0.9	0.26
5.0	0.9	0.73

The possibly steep drop in water surface elevation between the inlet pool and the contraction section of the culvert inlet may present difficulty to upstream-swimming fish attempting to exit the culvert. This is because the slope of the water surface (hydraulic grade line) can represent significant gradient force, especially near the culvert walls at the inlet lip. This is also a zone of water acceleration, so adverse virtual mass forces act on fish here.

To calculate the water surface drop (ΔH), one must know the mean water velocity (V_B) in a cross section of the barrel immediately downstream from the inlet zone. (The value of V_B in a specific outlet or downstream control situation requires the calculation of a backwater curve from the culvert outlet to the vicinity of the inlet.) Previous discussion of the hydraulics and fish passage for the culvert barrel indicated that, for weak-swimming fish, mean barrel velocities must be kept to approximately 5 ft/sec (more or less depending on culvert slope and length), so it is possible to have a significant drop in water surface at the inlet of a culvert if the inlet protrudes into the inlet pool.

Horizontal skew of water approaching a culvert inlet affects the velocity distribution in the culvert (Figure IV-19). Though the writers have little data to quantify properly the results of skew on water flow velocities near the culvert wall where fish swim, it appears that the effects of skew extend for some distance downstream in the culvert. The writers'

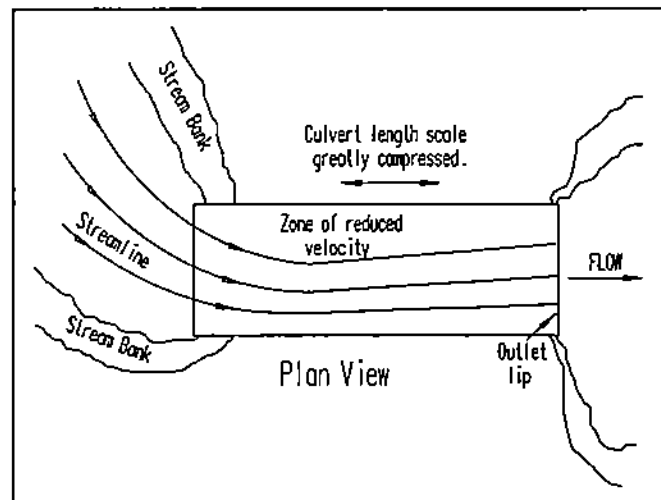

Figure IV-19. Conceptual sketch of how culvert skew reduces water velocity on one side of the culvert.

observations indicate if the skew angle is 30° to 45° , the near wall water velocity may be reduced to as little as one-tenth that of the mean water velocity in a cross section. This reduction in wall velocity on the "inside" wall may persist for 8 to 10 diameters downstream. The writers have documented this phenomenon in one culvert for its entire length, which, unfortunately, was only 6.3 diameters. In difficult situations, skewing a

culvert may produce the necessary reduction in near-wall water velocities to make fish passage possible.

IV.D.2. Hydraulics of Fish at the Culvert Inlet

The previous discussion of details of flow in the inlet zone and reference to Figure IV-18 suggest that fish are confronted with profile drag, gradient, and virtual mass forces while attempting to exit a culvert. Virtual mass and gradient forces can be reduced by improving culvert entrance conditions, as previously indicated. However, Figure IV-18 illustrates how fish can utilize the eddies at either side of the culvert at the inlet contraction zone. These eddies provide relatively quiet locations for fish to swim almost to the inlet lip of the culvert. The water surface in the eddies is usually rather flat, so there are "holes" in the water surface just inside the culvert at the lip against the culvert walls. Fish may rest in the eddies before challenging the culvert inlet. However, when they do, they are faced with the three forces mentioned previously.

Fish must swim a short distance to exit the culvert, usually only 1-3 ft. They seldom swim up the culvert centerline and challenge the high velocity of flow at the contraction point, only doing so when conditions are not difficult. Actually, the only importance of the contraction coefficient (C_c) to fish passage is that it determines the steepness of the piezometric "hill" which the fish must climb to exit the culvert and the acceleration rate of the water which determines the magnitude of the virtual mass force. When conditions are difficult, fish proceed from an eddy into the edges of the main stream very close to the inlet lip. There the water has not yet accelerated significantly, so the profile drag force on the fish is small.

A question often arises regarding the fish's dependence on these inlet eddies. The size of the eddies is clearly related to the entrance conditions. A small contraction coefficient results in wide eddies. However, this also results in a large drop in the water surface elevation at the inlet which creates large gradient and virtual mass forces. So a wide eddy at the inlet provides a fine resting location for fish, but it comes at a price. If a fish has been stressed in the white muscle mode at the outlet and has been able to get to the inlet while swimming in the red muscle mode, it may require a lengthy rest of its white system before it can attempt a difficult exit. However, if the exit is made easy by design, fish may be able to exit the culvert in the red muscle mode.

A culvert designed for weak-swimming fish should have approximately a 5-ft/sec average barrel velocity (depending on fish size and barrel length and slope). Where fish seem to enter the high-velocity stream from the inlet eddy, the water depth is greater than in the fully contracted zone, and the water has not yet attained a maximum contraction. Thus, the water velocity at that point is somewhat less than the mean cross-sectional velocity just downstream from the inlet contraction-expansion zone, but it is greater than the water velocity close to the edge of the culvert in the barrel. Therefore, it is computationally conservative to expect fish at this point to be faced with a velocity equivalent to the mean cross-sectional barrel velocity just downstream from the inlet zone. That velocity is usually determined by backwater computations initiated at the outlet lip.

If subcritical flow conditions exist in the culvert, as they usually should for passage of weak-swimming fish, conditions at the inlet do not present a great problem to those fish.

However, the computational method presented in Chapter V can also be utilized for other species and sizes of design fish.

The hydraulic condition at a culvert inlet is one of rapidly varied flow. Here it will be assumed that the pressure gradient in the water entering a culvert is proportional to the slope of the main stream water surface entering the culvert from the inlet pool to the point of maximum entrance contraction. Further, it is assumed that the pressure gradient in the entering water is a constant in this zone, so the hydraulic grade line (HGL) is considered to slope as a straight line. These assumptions are somewhat different from reality, but the variance appears to be small.

Fish follow many different paths in exiting a culvert. The writers have observed that when conditions are easy for the fish, they prefer to follow the invert. The design methods set forth here are for the upper limit of weak fish swimming capabilities. The swimming path shown in Figure IV-20 is that of many fish observed by the writers. It is not the only path, but it provides a basis for illustrating the computational method. If engineers observe other paths of exit from culverts, they may use the methods to compute energy and power expended by fish following those paths. The writers caution, however, that observations should be made during flows which truly stress the fish virtually to the limits of their capabilities. As noted above, swimming paths change as flow conditions change. Locations in a culvert where swimming may be easy under a low flow situation may be impossible at higher flows. Fish seek less difficult routes during design flows.

Figure IV-20 indicates that the water surface drops by an amount ΔH over a distance of 2-3 ft depending on local conditions which are most easily characterized by water surface width across the culvert inlet. The writers suggest that this distance be 2 ft for 9-ft diameter culverts or smaller and 3 ft for larger culverts. Clearly, this is not precise, but it offers reasonably realistic values.

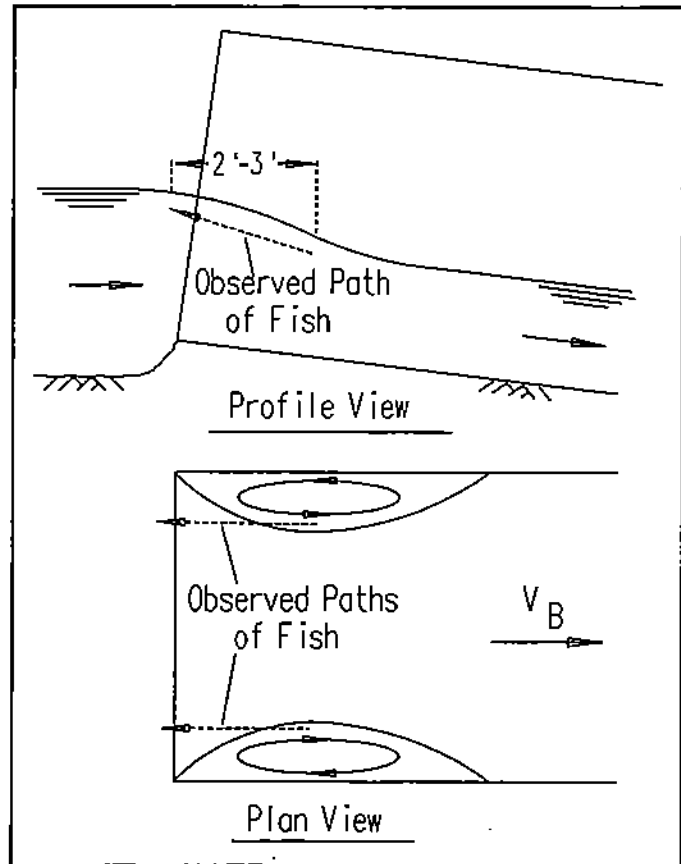

Figure IV-20. Observed fish passage routes at difficult inlet.

The gradient force (F_G) can be

calculated from Equation 3.6. Slope of the inlet water surface, defined by the angle θ in that equation, is simply $\Delta H/2$ ft or $\Delta H/3$ ft, depending on culvert diameter. Assuming that the slope of streamlines near the water surface, where Figure IV-20 suggests fish swim, is parallel to the water surface, then $\theta = \phi$. From this, the second trigonometric term in Equation 3.6 disappears.

The profile drag force is given by Equation 3.4. Aside from constants for the water's mass density (ρ) and kinematic viscosity (ν) and the design fish length (L), the water velocity (V_w) and fish velocity with respect to a fixed reference (V_f) must be calculated or assumed so V_{fw}

can be determined. An average value for V_w is assumed to be the average of the velocity at the fully contracted section (V_{ctr}) and zero velocity in the pool just upstream from the inlet. This is a simplistic assumption, but it appears to be close to reality. If the inlet is difficult for small fish (and it may not be if barrel velocities are small), they are assumed to move with $V_f = 1$ ft/sec. Thus, $V_{fw} = V_w + 1$ ft/sec, and this value is substituted into Equation 3.4.

Since this contraction zone is a point of water acceleration, the virtual mass force is calculated from Equations 3.9 and 3.10. Since the pool velocity head is assumed zero, ΔV is simply the velocity in the contracted section (V_{ctr}). Δs is either 2 ft or 3 ft depending on culvert size, as explained previously.

When the above three forces have been calculated, fish power can be calculated by multiplying the sum of the three forces by V_{fw} (Equation 3.15). The resulting power (P) must be checked against the 4-watt maximum power assumed to be the upper limit for grayling. The time required for the fish to move through this possibly difficult zone is either 2 or 3 sec depending, again, on culvert size. A 4-watt power output cannot be achieved for more than 3 sec in a single swimming burst. Total culvert design requires a 5-sec limitation on this level of power output for the sum of inlet and outlet passage times.

V. NEW CULVERT DESIGN

Chapter Summary:

Culvert barrel design for fish passage is discussed and specific design steps with appropriate equations are stated. Culvert outlet and inlet are similarly considered. For locations too steep for fish passage through plain or depressed invert culverts design steps are given for weir baffles.

V.A. Overview

This chapter will set forth the design steps necessary for the passage of *Class-I fish* through an outlet-controlled or downstream-controlled culvert. Some of this presentation is applicable to larger fish swimming under inlet or outlet control conditions. The chapter will discuss barrel, outlet, and inlet design for culverts with and without depressed inverts. This chapter will also indicate how to design weir baffles for placement in culverts which are too steep to support fish passage even if the invert is depressed.

Non-depressed invert (plain) corrugated, structural steel plate (SSP) culverts, depressed invert SSP culverts, and weir-baffled culverts are the designs which the writers feel can be modelled with some certainty. The Canadian offset baffles have a place under some conditions, but they appear to be susceptible to debris accumulation and they are relatively expensive, so their design will not be discussed here. If the design engineer wishes to use them, the necessary design equations are given in Chapter IV. Other systems discussed in Chapter IV do not lend themselves to computations, so design equations do not exist. Most

of them are worth experimenting with in retrofit situations. They are quite inexpensive. As these are used more, design equations will probably evolve.

Fish passage design flows (Q_f) are usually a small fraction of design-flood flows. Thus, the passage culvert need not function for fish passage when stream flows exceed Q_f . The designer should consider the possibility of two or more parallel culverts with one being designed to pass fish for total stream flows up to Q_f and the other culverts to pass larger flows. Various combinations of parallel culvert diameters, slopes, depression of inverts can be used where stream flow is large enough to warrant more than one culvert. The methods of this chapter design only the fish passage culvert. Others may be designed by standard methods, but the designer must be cautious that the design does not starve the fish passage culvert for stream flows up to Q_f . If the fish passage culvert and one or more other culverts function during flows of Q_f and less, the flow through the fish passage culvert will be less than the stream flow Q_f , depending on how the flow divides between/among culverts.

In the material which follows, the design steps and the appropriate equations from previous chapters are set forth. The basic approach to the design steps is to: (1) determine the useful power output that the design fish is capable of delivering, (2) design a culvert system which requires the design fish to utilize but not exceed its swimming capabilities, (3) check the design for passage of the design flood, and, if necessary, (4) repeat steps 2 and 3 until both passage requirements are met.

V.B. Culvert Design

V.B.1. Culvert Barrel Design Requirements for Fish Passage

The writers suggest that culvert alternatives for an installation be investigated in the following order:

- (1) Corrugated structural steel plate (SSP) culvert with no depression of invert.
- (2) SSP culvert with Type-1 DIC (see Figures IV-8 and IV-9).
- (3) Weir baffles of $0.1 D$ height.
- (4) Weir baffles of $0.15 D$ height.

If the first is unsatisfactory for fish passage, the design engineer moves on to the next, etc. until a satisfactory design is achieved. The above order is suitable for circular and elliptical culverts.

The procedures consist of the following steps:

(1) Input those parameters which will probably not change during the investigation of the type of device being checked for fish passage suitability. These are design fish length (L_f), culvert length (L_c), culvert slope (S_o), Manning roughness for corrugated culvert walls (n_s), and Manning roughness for the bed material, which will become the culvert invert if the culvert has a depressed invert (DIC).

(2) Calculate other stable parameters: (a) Time (t) for the design fish to swim through the culvert barrel at a velocity (V_f) of 0.1 ft/sec (for Class-I fish). (b) Power (P_o) which the design fish is capable of delivering for time period t . (c) Maximum barrel water velocity

(V_{avef}) which will allow the design fish to swim through the culvert, having slope S_o , in time t without exceeding its power delivery capability. (The designer must remember that the fish swims at a location where it is assumed that $V_{occ} = 0.4 V_{avef}$.) These calculations are independent of Q_f , D , and culvert depression (d).

(3) Input Q_f and trial values for culvert diameter D and culvert depression depth d .

(4) Calculate, for the trial culvert conditions, normal depth (y_n), average cross-sectional water velocity (V_n) at normal depth (y_n), average cross-sectional water velocity (V_c) at critical depth (y_c), and the depth of flow (y_{avef}) which corresponds to an average water velocity of V_{avef} in the culvert. All of these are difficult computations which require trial and error solutions, especially if the value of d is non-zero.

(5) If $Y_{avef} < y_n$ (i.e., $V_n < V_{avef}$) the barrel segment is acceptable for fish passage.

If $y_c < y_n < y_{avef}$, the culvert can be made acceptable provided the outlet depth (Y_o) is sufficient to provide for depth equal to or greater than y_{avef} everywhere in the culvert. That determination requires a backwater computation. (This alternative usually does not work without a good deal of backwater from the outlet pool.) If the above conditions are not met by the trial culvert, the design engineer should try a different value for D and/or d . Since fish passage design usually determines culvert diameter and invert depression and results in an overdesign for the design flood, the culvert should be designed to have y_n be only a small

amount greater than y_{avef} to avoid uneconomic overdesign for both fish passage and the design flood. If a suitable configuration cannot be found for fish passage, the design engineer should consider moving on to a weir baffled culvert design.

(6) Check outlet and inlet conditions for the accepted culvert barrel to be sure that outlet depth (Y_o) does not result in unacceptable outlet water velocity or culvert perching and that the inlet conditions are not too difficult for the fish.

(7) Check the culvert(s) for safe passage of the design flood.

V.B.1.a. Specific Culvert Barrel Design Steps

Input Step (1): Input parameters which are usually fixed for the culvert design. Input culvert length (L_c), culvert slope (S_o), Manning roughness for corrugated walls (n_s), Manning roughness for bed material if culvert is depressed (n_b), fork length (L_f) of Class-I design fish.

Calculation Step (1): Calculate design fish's red muscle power capabilities (P_c) for the time period the fish is in the culvert.

(a) Time (t) required for fish to pass through culvert. V_f is assumed to be 0.1 ft/sec for Class-I fish, so

$$t = \frac{L_c}{V_f} = \frac{L_c}{0.1} \quad \text{-----Eq. 5.1}$$

(b) From Chapter III, fish length is assumed to be

$$L = \frac{L_f}{0.92} \quad \text{-----Eq. 5.2}$$

(c) Fish power *capability* assuming profile drag only,

$$\begin{aligned} V_{fvc} &= (\text{Eq. 3.13b}), \\ &= 6.98 L^{0.55} t^{-0.08}, \quad \text{-----Eq. 5.3} \\ &= 6.98 (\text{Eq. 5.2})^{0.55} (\text{Eq. 5.1})^{-0.08}. \end{aligned}$$

$$\begin{aligned} F_{Dc} &= (\text{Eq. 3.4}), \\ &= 0.0576 (\rho) (\nu)^{0.2} L^{1.8} V_{fvc}^{1.8}, \quad \text{-----Eq. 5.4} \\ &= 0.0576 \rho \nu^{0.2} L^{1.8} (6.98 L^{0.55} t^{-0.08})^{1.8}, \\ &= 0.0576 \rho \nu^{0.2} (\text{Eq. 5.2})^{1.8} (\text{Eq. 5.3})^{1.8}. \end{aligned}$$

$$\begin{aligned} P_c &= F_{Dc} V_{fvc}, \\ &= 0.0576 \rho \nu^{0.2} L^{1.8} V_{fvc}^{2.8}, \quad \text{-----Eq. 5.5} \\ &= 0.0576 \rho \nu^{0.2} (\text{Eq. 5.2})^{1.8} (\text{Eq. 5.3})^{2.8}. \end{aligned}$$

Here V_{fvc} is V_{fv} which fish is *capable* of achieving in absence of gradient and virtual mass force, F_{Dc} is the profile drag force which fish is *capable* of achieving in absence of other forces, and P_c is the power which a fish of length L is *capable* of delivering for time period t .

Calculation Step (2): Calculate maximum culvert V_{avef} which will allow fish passage.

(a) Equate fish power capability (P_c) to necessary output (P).

$$P_c = (\text{Eq. 5.5}).$$

$$P = (\text{Eq. 3.15}) = (F_D + F_G) V_{fw} \text{ (ignoring } F_m). \quad \text{-----Eq. 5.6}$$

$$\text{Eq. 5.5} = (\text{Eq. 3.4} + \text{Eq. 3.9a}) V_{fw}.$$

Equation 5.6 is solved for V_{fw} by trial-and-error. This V_{fw} is the V_{occ} which the design fish can sustain in the culvert barrel set at the slope S_o . It is less than V_{fwc} calculated by Equation 5.3 which was for $S_o = 0$.

(b) Calculate V_{avef} from V_{occ} .

$$V_{fw} \text{ (as calculated from Eq. 5.6)} = V_{occ}.$$

$$V_{avef} = \frac{V_{occ}}{0.4} \text{ (from Chapter IV)}. \quad \text{-----Eq. 5.7}$$

Input Step (2): Input parameters which may change during the remainder of the design iteration procedure. Input fish passage design flow (Q_f) for the culvert being designed (may be less than the stream Q_f if parallel culverts are selected), trial culvert diameter (D), and trial invert depression depth (d).

Calculation Step (3): Calculate normal depth (y_n), velocity of flow at normal depth (V_n), critical depth (y_c), and velocity of flow at critical depth (V_c) for the conditions thus far input.

(a) Calculate y_n by trial-and-error solution of the Manning equation.

$$Q_f = \left[\frac{1.49}{n} \right] A_n R_n^{2/3} S_o^{1/2}, \quad \text{-----Eq. 5.8}$$

where A_n and R_n are the cross-sectional area of flow and the hydraulic radius, respectively, at normal depth, and n is a composite n of culvert sides and bottom material depending on use of depressed invert. y_n is found by trial and error solution of Equation 5.8.

(b) Calculate critical depth by trial-and-error solution of Equation 4.1 for $Q = Q_f$.

$$\frac{Q_f^2 B_c}{g A_c^3} = 1, \quad \text{-----Eq. 4.1}$$

where B_c and A_c are water surface width and cross-sectional area of flow, respectively, at critical depth. y_c is found by trial-and-error solution of Equation 4.1.

(c) Calculate depth of flow (y_{avef}) for Q_f flowing at velocity V_{avef} . This requires using geometric properties of the culvert defined by Input Step (2) to determine depth (V_{avef}) for which $Q_f/A = V_{avef}$. This involves a trial-and-error solution.

Decision Point (1):

(a) If $y_{avef} < y_n$ (i.e., $V_{avef} > V_n$) then barrel design is acceptable (stop barrel design), else

(b) GOTO Input Step (2) and increase D and/or d and begin procedure again at that point until design is acceptable to here, else

- (c) If $y_n > y_c$, then consider raising outlet pool control to provide a backwater situation in the barrel suitable to provide $y > y_{avef}$ everywhere in the culvert, else
- (d) If step (c) requires unreasonable outlet control design, then
- (e) Move on to weir baffles design.

V.B.2. Outlet Requirements

Review of and frequent reference to Figures IV-1 and IV-2 are necessary to understand this section. Also, the design engineer must generate, either from stream gaging or by the methods of "Hydraulic Design Series No. 8, Culvert Analysis, Microcomputer Programs Applications Guide (and software)" (1987), a rating curve of the outlet pool as it will be when construction is completed. The rating curve determines the relationship between the outlet pool tailwater elevation (TW) for the culvert and Q , so it is necessary for proper analysis of the outlet hydraulics. The availability of this curve is assumed in the discussion which follows.

Except for shallow flows, weak-swimming fish require subcritical flow in the culvert.

However, in the unusual case where $y_c > y_n > y_{avef}$ and $TW \geq y_{avef}$, the culvert is acceptable for passage of weak-swimming fish even though the flow is supercritical. The design methods which follow allow for this unusual situation. However, unless otherwise stated, the methodology assumes $y_n > y_c$.

Reference to Figures IV-1 and IV-2 indicates the outlet pool elevation (TW) might be equal to or less than the culvert outlet depth (Y_o) for the fish passage design flow (Q_f). For reasons explained in Chapters III and IV, it is desirable not to have perched or partially perched culvert outlets. If this criterion is met, then $TW = Y_o$, and both are equal to or greater than critical depth (y_c).

Assuming the design engineer has already arrived at a satisfactory barrel design (which implies $y_c < y_{avef} \leq y_n$), if $Y_o \geq y_{avef}$ for Q_f , the outlet is safe for fish entering the culvert, and the design engineer can leave the outlet design and move on to investigate the inlet for safe passage. If $Y_o < y_{avef}$, an outlet zone exists between the outlet and a point upstream within which the sum of profile drag force (F_D), gradient force (F_G), and virtual mass force (F_{vm}) are too great for the design fish to swim against in the red muscle mode. Consequently, it must resort to the white muscle mode in attempting to move upstream through the outlet zone to the point where y_{avef} and V_{avef} exist.

To determine the extent of the outlet zone, the design engineer must first calculate (with Y_o as initial input) an M-2 backwater profile upstream from the outlet through the barrel to the inlet. The entire backwater curve is not necessary for outlet design, but it will be required later for inlet design purposes.

Water depth increases and velocity decreases with distance from the outlet where an M-2 water surface profile exists (i.e., $y_c < y < y_n$). Thus, as a fish swims upstream in M-2 type flow the white muscle power requirement decreases to zero where the depth of flow reaches y_{avef} . At that point white muscle activity is no longer needed and red muscle swimming takes over. The writers have found that white muscle power output of 4 watts for a total time period not to exceed 3 sec while travelling through a culvert outlet zone is safe for Class-I fish of which the $L_f = 240$ -mm grayling is the basic model. This is a total white muscle energy expenditure of $4 \times 3 = 12$ watt-sec (joules). Though white muscle power requirements do not decrease linearly from the outlet, for calculation purposes they can be assumed to do so with little error. Thus, the writers assume that white muscle power requirements reduce from their maximum in the first foot of the outlet zone to a smaller value as the fish approaches the upper end of the outlet zone. At the end of the outlet zone (where $y = y_{avef}$) fish shift from white muscle to red muscle swimming, and the writers assume that V_f changes from 1 ft/sec to 0.1 ft/sec. Since a fish rather suddenly slows its V_{fw} at that point, its power delivery is commensurately reduced, though V_{occ} changes little as the fish moves across the outlet zone boundary. The writers have observed this quite pronounced shift from white muscle to red muscle swimming at difficult culvert outlets.

Because power requirements change quickly in the initial foot from the outlet lip, the writers suggest that the fish's power delivery at the outlet lip (P_{outlet}) be assumed to be the average power requirement for the initial foot of the culvert. From step-by-step (upstream from the outlet lip) backwater computations, the swimming power requirement in the initial foot of the

culvert and that at discrete distances upstream from the outlet can be computed. From average power in the initial foot and at another point upstream where V_{ave} is still slightly greater than V_{avef} , the distance upstream to the point of zero white muscle requirement can be found, and the total white muscle *energy* consumed in the outlet zone can be calculated.

With outlet depth at the culvert lip (Y_o) less than y_{avef} , and the extent of the outlet zone (where $y < y_{avef}$) known from backwater computations, it is necessary to calculate the power and energy which the design fish would have to produce to pass through the difficult zone. Since, for $y_c < y_n$, each of F_D , F_G , and F_{vm} decreases as the fish moves upstream through the outlet zone, a calculation of both the average value for these three forces in the first foot of the culvert (from the outlet) and the power necessary to overcome these average force values determines the maximum power which the fish must deliver in the outlet zone.

White muscle *energy* produced by the fish in passing through the outlet zone (E_{outlet}) is

$$E_{outlet} \approx \left[\frac{P_{outlet} + P_{us}}{2} \right] \left[\frac{\Delta s_{outlet}}{V_f} \right], \quad \text{-----Eq. 5.9.}$$

where P_{outlet} is the previously described power delivered by the fish in entering the culvert, P_{us} is the white muscle power delivered at the upper end of the outlet zone, and Δs_{outlet} is the length of the outlet zone. There $V_{occ} = 0.4 V_{avef}$, and $V_f = 1$ ft/sec; so $V_{fw} = 0.4 V_{avef}$

+ 1 ft/sec. When weak-swimming fish move with a velocity of 1 ft/sec with respect to the culvert (V_f), then,

$$E_{outlet} = \left[\frac{P_{outlet} + P_{us}}{2} \right] (\Delta s_{outlet}). \quad \text{-----Eq. 5.10}$$

Criteria for passage of a Class-I, $L_f = 240$ -mm fish through the outlet zone, whatever its length may be, are: (1) P_{outlet} should not exceed 4 watts, and (2) E_{outlet} must not exceed 12 joules. If the barrel has been designed to pass fish properly, but these two outlet criteria have not been met, it is necessary to increase the outlet pool depth (TW) in order to increase Y_o and decrease the length of the outlet zone. If this does not produce a satisfactory solution, the barrel must be redesigned.

In the discussion of barrel design the writers assumed that V_{occ} is $0.4 V_{ave}$. However, in a zone of rapidly accelerated flow it is expected that the velocity distribution across a flow cross section would be more uniform than elsewhere in the barrel. Measurements by the writers (Kane et al., 1989) indicate that this is true. A review of those data indicates that V_{occ} is approximately $0.6-0.8 V_{ave}$ in situations where the outlet depth (Y_o) is close to y_c .

Thus, for outlet computations of F_D , F_{vm} , and P , it is safe, for fish passage, to assume that $V_{occ} = 0.8 V_{ave}$ at the culvert outlet and 1 ft upstream from the outlet. (Since this assumption is based on limited data, the relationship may be better defined with the gathering

of more data.) However, for the computation of F_D and P_{w} at the farthest upstream point in the outlet zone, it is safe to assume that V_{occ} is $0.4 V_{ave}$.

In actual practice, the design engineer will find in most cases that if the barrel design meets the barrel criteria and the outlet pool tailwater depth is equal to or greater than the critical depth ($TW \geq y_c$), there will be no outlet problem for weak-swimming fish. However, since this is not always true, it is wise to check the outlet design to make certain that it does not present a problem. Also, if subsequent computations for inlet design indicate a problem there, the designer may wish to reduce the amount of white-muscle energy required at the outlet so that more is available to be used at the inlet. To do this, TW (and Y_o) would need to be suitably increased.

Chapter IV considers, also, desired fish passage flows which are less than the design fish passage flow (Q_f). The discussion of the y - Q in that chapter is particularly useful.

V.B.2.a. Design Calculations for Culvert Outlet Zone

Input Step (1):

- (a) Input L_f or L , Q_f , D , d , n_s , and n_b (same as barrel inputs).
- (b) Input y_c , y_{ave} , and y_n from the previous barrel design.
- (c) Input the outlet tailwater depth TW (which = Y_o) for Q_f . TW must be determined

from a rating curve for the outlet pool as it will be after construction. The rating curve is

determined separately using techniques in "Hydraulic Design Series No. 8, Culvert Analysis, Microcomputer Programs Applications Guide (and software)" (1987).

Decision Point (1): If $y_c > y_n$, then GOTO Decision Point (1.A), else

Decision Point (2): To this point $y_n > y_c$. If $y_{avef} > y_n$, then GOTO Computation Step (1.A), else

Decision Point (3): To this point $y_n \geq y_{avef} \geq y_c$. If $TW < y_c$, then GOTO Computation Step (2.A), else

Decision Point (4): If $TW \geq y_{avef}$, outlet is no problem; GOTO Inlet Design, else

Computation Step (1): Backwater curve through the culvert. To this point

$y_n \geq y_{avef} \geq y_c$, and $TW \geq y_c$.

For $Y_o = TW$, calculate backwater curve from outlet lip to inlet pool. (Refer to open channel hydraulics text.)

Computation Step (2): Determine length of outlet zone (Δs_{outlet}) by plotting the backwater curve and noting the location from the outlet (from $x = 0$) along the culvert (x location) to where $y = y_{avef}$. This can also be calculated approximately by various techniques. This calculation or estimation does not have to be precise since the standards of 4 watts and 12

joules as acceptable power and energy expenditures for a Class-I, $L_f = 240$ -mm fish in the outlet zone are not precise enough to warrant a high level of precision in determination of

$$\Delta s_{outlet}$$

Computation Step (3): Determine necessary white muscle power at the outlet (P_{outlet}) and at the upstream end of the outlet zone (P_{up}), and the white muscle power capability of the design fish (P_{cw}). Calculate maximum swimming power which the fish must produce to pass through the initial foot of the culvert.

(a) From backwater calculations, identify y and V_{ave} at outlet and 1 ft upstream from the outlet.

(b) Calculate the average F_D , F_G , and F_{vm} for this 1-ft zone.

$$F_D = 0.0576 (\rho) (v)^{0.2} L^{1.8} V_{fw}^{1.8}, \quad \text{-----Eq. 3.4}$$

where

$$V_{fw} = V_f + 0.8 \frac{V_{ave-outlet} + V_{ave-1'}}{2}, \quad \text{-----Eq. 5.13}$$

$$= 1 \text{ ft/scc} + 0.8 \frac{V_{ave-outlet} + V_{ave-1'}}{2}. \quad \text{-----Eq. 5.13a}$$

$$F_G = W (\sin \phi + \cos \phi (\tan (\theta - \phi))), \quad \text{-----Eq. 3.6}$$

$$F_G = 0.007 \gamma L^3 (\sin \phi + \cos \phi (\tan (\theta - \phi))), \quad \text{-----Eq. 5.14}$$

where, from Equation 3.9b (for grayling), $W = 0.007 \gamma L_3$, ϕ is the arc tangent of the culvert slope, and θ is the arc tangent of the slope of the water surface in this rapidly varied flow zone. The elevation of the water surface (assumed to be the elevation of the hydraulic grade line) at the point 1 ft upstream from the outlet is $y_{1'} + 1' \left(\sin(\tan^{-1} S_o) \right)$. For almost any culvert, S_o is small enough that $\cos \phi \approx 1$, and $\sin \phi \approx \tan \phi$.

$$\theta = \tan^{-1} \left[\frac{y_{1'} + S_o - Y_o}{1'} \right]. \quad \text{-----Eq. 5.15}$$

These values for ϕ and θ are substituted into Equation 5.14 to obtain the value for F_G .

For successful passage of weak-swimming fish the virtual mass force must be very small in relation to F_D and F_G , so it need not be calculated. However, since these methods can also be used for strong-swimming fish, its computation is included here. The virtual mass force (F_{vm}) is expressed as

$$F_{vm} = 1.2 \left[\frac{W}{g} \right] a_{fw}, \quad \text{-----Eq. 3.10}$$

where a_{fw} is approximated as

$$a_{fw} = (V_{fw})_{ave} \frac{\Delta V_{fw}}{\Delta s}. \quad \text{-----Eq. 3.11}$$

Thus,

$$F_{vm} = 1.2 \left[\frac{W}{g} \right] (V_{fw})_{ave} \frac{\Delta V_{fw}}{\Delta s}, \quad \text{-----Eq. 5.16}$$

where ΔV_{fw} is the difference in V_{fw} between the outlet $V_{occ} + V_f$ and that 1 ft upstream from the outlet, and Δs is 1 ft. Since the fish is assumed to swim with a constant V_f of 1 ft/sec, and V_{occ} is assumed to be $0.8 V_{ave}$ at any cross section of the culvert, the average value for V_{fw} in the initial foot of the outlet zone is

$$V_{fw} = 0.8 \left[\frac{V_{ave-outlet} + V_{ave-1'}}{2} \right] + 1 \text{ ft/sec}, \quad \text{-----Eq. 5.17}$$

and Equation 5.16 becomes

$$V_{fm} = 1.2 \left[\frac{W}{g} \right] \left[0.8 \left[\frac{V_{ave-outlet} + V_{ave-1'}}{2} \right] + 1 \text{ ft/sec} \right] \left[0.8 \left[\frac{V_{ave-outlet} - V_{ave-1'}}{1 \text{ ft}} \right] \right]. \quad \text{-----Eq. 5.18}$$

The power (P_{outlet}) the fish must produce in order to overcome the three forces in the first foot of the outlet zone is calculated from Equation 3.15, which for the outlet is

$$P_{outlet} = (F_D + F_G + F_{vm}) (V_{fw}), \quad \text{-----Eq. 5.19}$$

where V_{fw} is as calculated from Equation 5.17.

P_{us} is calculated similarly to P_{outlet} with the following exceptions. Since this point is well upstream of appreciable acceleration, the virtual mass force (F_m) can be ignored, and $V_{occ} = 0.4 V_{avef}$, so $V_{fw} = 0.4 V_{avef} + 1$ ft/sec. Also, $F_G = W \sin \phi$, so

$$P_{us} = (F_D + F_G) (F_{fw}). \quad \text{-----Eq. 5.20}$$

From Equation 3.21 and the assumed 4-watt white muscle capability of the standard Class-I, $L_f = 240$ -mm fish,

$$P_{cv} = 4 \left[\frac{L_f}{240} \right]^{2.46}. \quad \text{-----Eq. 5.21}$$

Decision Point (4): If $P_{outlet} > P_{cv}$, then GOTO Computation Step (3.A), else

Computation Step (4): Determine energy delivered in the outlet zone, i.e., E_{outlet} . Average power delivered in the outlet zone is assumed to be the average of that in the initial foot of the outlet zone and that at the upstream end of the outlet zone. Since energy delivered is the product of the average power in the outlet zone and the time required to move through the outlet zone,

$$E_{outlet} = \left[\frac{P_{outlet} + P_{us}}{2} \right] \left[\frac{\Delta s_{outlet}}{V_f} \right]. \quad \text{-----Eq. 5.22}$$

Decision Point (5): If $E_{outlet} > E_{allowable}$, ($E_{allowable} = 12$ joules for the Class-I, 240-mm fish at the outlet), then GOTO Computation Step (3.A), else outlet design is conditionally acceptable, so GOTO Inlet Design. Final acceptance of outlet design will depend on results

of inlet design. Barrel and/or outlet design may have to be changed if inlet design cannot be made acceptable for the barrel and outlet conditions thus far designed.

Decision Point (1.A): If $y_{avef} > y_n$, then select larger D and/or d and GOTO Barrel Design or GOTO Weir-Baffle Design, ELSE

Decision Point (1.A.1): If $y_{avef} > TW$, then design outlet pool control for $TW = y_{avef}$ for $Q = Q_f$. ELSE outlet design is conditionally acceptable, GOTO Inlet Design.

Computation Step (1.A): Design outlet pool TW so it is large enough to assure $y \geq y_{avef}$ everywhere in the culvert barrel, then GOTO Inlet Design.

If $y \geq y_{avef}$ everywhere in the culvert, the outlet zone and all of the culvert barrel up to the inlet zone is safe for fish passage. If $y_c < y_n < y_{avef}$, safe passage will occur only if TW is sufficiently large to provide $y \geq y_{avef}$ everywhere in the culvert. The value of TW necessary to accomplish this is determined either by means of backwater computations from the inlet end of the culvert (assuming y_{avef} at that point) downstream to the outlet (where $TW = Y_o$), or by trial and error, using backwater curves calculated upstream from trial values of Y_o . The goal of the upstream-directed computations is to determine the value of Y_o necessary to provide y_{avef} at the inlet end of the culvert. These computations are carried out also by normal backwater computation techniques. The culvert will, of course, be safe if $TW = y_{avef} + L_c (S_o)$; however, for long culverts this results in excessive TW . Continue.

Decision Point (1.A.2): If TW of Computation Step (1.A) is unreasonable, GOTO Weir-Baffle Design, ELSE GOTO Inlet Design.

Computation Step (2.A): The culvert is perched or partially perched. Increase TW so that $Y_o \geq y_c$, then GOTO Computation Step (1).

Computation Step (3.A): The fish is delivering too much power and/or energy at the outlet zone. To reduce this, increase TW (thereby increasing Y_o), then GOTO Computation Step (1).

V.B.3. Inlet Requirements

The inlet of a culvert usually is associated with significant acceleration of the entering water. As has been pointed out in Chapter IV, this acceleration results in increasing kinetic energy and a rather abrupt drop in the water surface profile of the incoming water. These factors mean that, at the inlet, fish attempting to exit the culvert barrel are faced with profile drag, gradient, and virtual mass forces. Depending on the magnitudes of the factors which contribute to these forces, this may be a difficult location for fish to pass through. In most cases, fish will probably be forced to utilize their white muscle systems to move out of the culvert. In this sense, if the fish has expended several seconds of white muscle energy to move from the outlet lip to the point where the $y \geq y_{avg}$, then the fish cannot be exposed again to several seconds of white muscle activity at the inlet of the culvert. If the potential white muscle energy expenditure at the outlet and inlet appears to extend beyond 20 joules (for the Class-I, 240-mm fish), and the inlet exposure cannot be reduced, it may be necessary

to redesign the outlet pool tailwater elevation (TW) to shorten the white muscle exposure at that location. If, for example, white muscle energy usage at the outlet can be reduced from 12 to 6 joules, then it would be possible for the fish to generate the maximum 4 watts of power for 3 sec to yield 12 joules of energy output at the inlet (which is its maximum single-burst white muscle energy output) instead of a maximum 8 joules if 12 joules had been expended at the outlet.

Since the inlet zone of a culvert (that zone from the inlet lip to the point of maximum inlet contraction) is a zone of rapidly varied flow, conditions change rapidly for the fish as it moves through it. It is thus necessary to compute the fish's power requirements as it moves through the most difficult location in the zone. The engineer must estimate where that location is. The writers assume the fish moves in the active, contracting water stream as the stream enters the culvert. They further assume that the slope of the water surface is relatively constant from the inlet lip to the point of maximum contraction and that the contraction point occurs 2 ft downstream from the inlet lip for culvert diameters up to and including 9 ft and 3 ft downstream from the inlet lip for culvert diameters greater than 9 ft. From miscellaneous observations of culvert inlets by the writers, these assumptions appear generally reasonable though certainly not precise for all culverts under all conditions.

The drop of water surface in the contraction zone (ΔH) is calculated from Equation 4.41. However, it is necessary first to know the depth of flow in the barrel just downstream from the inlet zone (which is obtained from backwater computations from the outlet end of the

culvert). It then is necessary to know the entrance loss coefficient, K_e (See Chapter IV), which depends on the type of entrance condition selected for the culvert.

The velocity of flow which the fish is assumed to face at the culvert entrance is $0.8 V_{cur}$, where V_{cur} is the average velocity in the contracted section. This is given by Equation 4.39. Since both the drop in water surface elevation and the water velocity at the contracted section increase with K_e , it is clear that difficult entrance conditions may be minimized if K_e can be reduced.

V.B.3.a. Design Calculations for Culvert Inlet Zone

Input Step (1): Input additional information not already input for barrel or outlet designs.

(a) Input the calculated depth of flow (y) and the water velocity (V_{ave}) for the inlet lip from the backwater calculations of the outlet design procedure. The value of V_{ave} input here is the barrel velocity (V_B) used to calculate the contracted section velocity (V_{cur}).

(b) Input the inlet loss coefficient for the inlet type, i.e., projecting, headwall, or bevelled headwall, as it would appear to the flow for discharge Q .

Calculation Step (1): Calculate water velocity at the inlet contracted section, to be used in subsequent calculations of F_D , F_G , F_{vm} , and P at inlet.

$$\frac{V_{cur}^2}{2g} = (1 + K_e) \frac{V_B^2}{2g} \quad \text{-----Eq. 4.39}$$

$$V_{cur} = (1 + K_e)^{1/2} V_B \quad \text{-----Eq. 5.23}$$

Calculation Step (2): Calculate drop in water surface (ΔH) between the inlet pool surface and the water surface at the contracted section. If the inlet pool approach velocity head can be ignored,

$$\begin{aligned} \Delta H &= \frac{(V_{cur})^2}{2g} \\ &= (1 + K_e) \frac{V_B^2}{2g}. \end{aligned} \quad \text{-----Eq. 4.41}$$

Calculation Point (3): Calculate F_D , F_G , F_{vm} , and Power required for design fish to swim through inlet of culvert as designed. Assuming the fish swims where the water velocity is $0.8 (V_{cur})$ and that the fish swims with $V_f = 1$ ft/sec,

$$\begin{aligned} V_{fw} &= 1 \text{ ft/sec} + 0.8 \text{ (Eq. 5.23)}, \\ &= 1 \text{ ft/sec} + 0.8 (1 + K_e)^{1/2} V_B, \end{aligned} \quad \text{-----Eq. 5.24}$$

where V_B is V_{ave} calculated for the inlet lip from the outlet backwater computations.

$$F_D = 0.0576 (\rho) (\nu)^{0.2} L^{1.8} V_{fw}^{1.8}. \quad \text{-----Eq. 3.4}$$

The fish is assumed to swim horizontally and the drop in water surface (ΔH) is assumed to occur over a distance Δs of 2 ft if $D \leq 9$ ft, otherwise Δs taken as 3 ft. Thus the gradient force is

$$F_G = W \left(\sin \phi + \cos \phi (\tan (\theta - \phi)) \right), \quad \text{-----Eq. 3.6}$$

where $\phi = 0$, and $\theta = \tan^{-1} (\Delta H / \Delta s) = \tan^{-1} (\text{Eq. 4.41} / \Delta s)$, thus,

$$F_G = W \left[\frac{\Delta H}{\Delta s} \right]. \quad \text{-----Eq. 5.25}$$

To calculate F_{vm} it is necessary to make an assumption regarding the water velocity at the culvert inlet or at some point upstream in the close proximity to the culvert. Here the writers assume the velocity of approach is negligible at a point 2 ft upstream from the culvert inlet lip and accelerates uniformly to the point of maximum contraction where the velocity is V_{ctr} . Since the fish would swim near the edges of the inflow stream, it is assumed that the velocity which the fish encounters is eight-tenths of the average velocity in the incoming stream. As at the outlet, this is a location of probable difficulty for the fish, so it is assumed to swim at a V_f of 1 ft/sec in this inlet zone. When the fish clears the inlet lip, it is assumed to have passed through the zone of difficulty. For the fish at the location of maximum difficulty, which is probably somewhere between the contracted section and the inlet lip, a conservative estimate of V_{occ} would be $V_{occ} = 0.8 V_{ctr}$. Thus,

$$F_{vm} = 1.2 \left[\frac{W}{g} \right] (V_{fw})_{ave} \frac{\Delta V_{fw}}{\Delta s}, \quad \text{-----Eq. 5.26}$$

$$F_{vm} = 1.2 \left[\frac{W}{g} \right] (1 \text{ ft/sec} + 0.8 V_{ctr}) \frac{0.8 V_{ctr}}{\Delta s}, \quad \text{-----Eq. 5.27}$$

where Δs is 2 ft for culvert diameters up to 9 ft and 3 ft for other diameters, and W and V_{ctr} have been calculated above.

Power is calculated from Equation 3.15 as follows:

$$P_{inlet} = (F_D + F_B + F_{vm}) (1 \text{ ft/sec} + 0.8 V_{ctr}), \quad \text{-----Eq. 5.28}$$

The energy required for the fish to negotiate the inlet zone is simply the product of power generated by the fish and the time required to pass through the inlet zone. The time required

depends on the culvert diameter and the velocity of the fish with respect to the culvert.

Since it is assumed that the fish swims with $V_f = 1$ ft/sec, the time required for the fish to swim through the inlet zone is 2 sec for $D \leq 9$ ft and 3 sec otherwise. Thus,

$$E_{inlet} = P_{inlet} \frac{\Delta S_{inlet}}{V_f} \quad \text{-----Eq. 5.29}$$

If $D \geq 9$ ft, the fish is assumed to swim for 3 sec in the white muscle mode while passing through the inlet zone. For such culverts it may be necessary to reduce the criterion of 3 sec of white muscle swimming at the outlet to 2 sec (or less) in order to leave enough white muscle capability for passage through the inlet zone. However, energy requirements as well as power requirements must be checked to be certain that the design fish is not required to exceed its white muscle power capabilities anywhere. These limits are (1) that total white muscle power and energy delivery not exceed the fish's white muscle capability to produce 4 watts for a total of 5 sec, i.e., 20 joules of energy for 240-mm grayling, before requiring a substantial rest period, and (2) that an individual burst of white muscle activity not exceed 4 watts of power for 3 sec at any single location in the fish's passage through the culvert.

V.B.4. Weir-Baffle Design

When culvert slopes are too great to allow for fish passage through depressed or non-depressed invert culverts, weir baffles (discussed in Chapter IV) offer an option which is less expensive than Canadian offset baffles.

The weir baffle discussion of Chapter IV related to streaming flow over weir baffles located in culverts, i.e., relatively plane water surface profiles through the culvert including over the

weir baffles. Thus, the slope of the water surface profile over the weir baffles is assumed to equal the culvert slope (S_o).

In each cell between successive baffles there are locations where water velocities are quite small, so fish have locations in which they can rest, for long periods if necessary, between successive white muscle exertions to clear successive baffles. Also, if they are capable of moving over a baffle, they are expected to do so quickly (in a second or less). For these reasons, if the fish's white muscle power limits are not exceeded at each baffle, its *energy* expenditure at each baffle is probably not important. Thus, white muscle *power* capability is assumed to be the limiting factor for fish passage through a weir-baffled culvert.

It is important that the outlet pool water surface elevation (TW) be the same as the water surface elevation in the cell between the first two baffles. (This is accomplished by appropriate controls for TW .) Weir baffles should be located in the culvert so that the most downstream baffle is only a foot or two upstream from the outlet lip. This minimizes the value of TW necessary for fish to enter the culvert.

Baffle heights of $0.1 D$ and $0.15 D$, both at spacings of $0.6 D$, are considered here. The smaller baffle height is preferred because of cost and because it probably will cause less debris to accumulate. However, since the larger weir baffle has better energy dissipation characteristics and provides better fish passage hydraulics, it must be used for larger slopes. Though these weir baffles have been tested only to slopes of 5 percent, they probably offer some potential for fish passage for greater slopes.

The velocity equations for V_{occ} (Eqs. 4.35 and 4.36) developed in Chapter IV for weir baffles relate principally to passage of weak-swimming fish and assume that the fish will swim close to the culvert wall as they pass over each weir baffle. (Stronger-swimming fish would probably chose another passage location when moving over each baffle.)

Because no information is available for the flow characteristics of weir baffled culverts flowing full with headwater elevations $> 0.9 D$, it is prudent to assume a depth in the culvert of no more than $0.9 D$ for the design flood. In many cases this will not affect culvert diameter, because that will be dictated by fish passage considerations.

The design procedure essentially consists of the following steps:

- (1) Input the knowns, which are Q_f , S_o , L_f , L_c , design flood Q , and a trial D .
- (2) Calculate the white muscle power capability (P_{cw}) of the fish if it is not a Class-I, 240-mm fish for which $P_{cw} = 4$ watts.
- (3) Calculate the water velocity of flow (V_{occ}) next to the culvert wall at the typical baffle.
- (4) For the input S_o and L_f and the value of V_{occ} calculated in step (3), calculate the profile drag (F_D) and gradient force (F_G) acting on the fish as it passes over a typical baffle.
- (5) Calculate the power the fish must expend while swimming against the forces calculated in the previous step.
- (6) Compare the power of step (5) with that determined in step (2). If that of step (5) is greater than that of step (2), then a new, larger trial D must be selected and the process repeated until the culvert can sustain fish passage.

(7) Check the culvert for passage of the design flood. If the culvert cannot pass the design flood at a depth of $0.9 D$ or less, a larger diameter must be selected which properly passes the design flood.

V.B.4.a. Specific Weir-Baffle Design Steps

Input Step (1): Input parameters which are fixed for the culvert design. Input culvert length (L_c), design fish fork length (L_f), culvert slope (S_o), fish passage design flow (Q_f), and design-flood flow (Q).

Input Step (2): Input trial variable. Input trial culvert diameter (D) and relative height of weir baffles ($0.1 D$ or $0.15 D$).

Calculation Step (1): Calculate design fish's white muscle power capabilities (P_{cw}). From Equation 5.21,

$$P_{cw} = 4 \left[\frac{L_f}{240} \right]^{2.46} \quad \text{-----Eq. 5.28}$$

Calculation Step (2): Calculate the dimensionless discharge Q_* . (Equations are from Chapter IV.)

$$Q_* = \frac{Q_f}{(g S_o D^3)^{0.5}} \quad \text{-----Eq. 4.12}$$

Calculation Step (3): Calculate dimensionless depth at the weir baffle (Y_p/D). For weir-baffle height = $0.15 D$,

$$\frac{Y_p}{D} = 0.41 (Q^*)^{0.202} \quad (\text{for } Q^* < 0.4), \quad \text{-----Eq. 4.31a}$$

$$\frac{Y_p}{D} = 0.5 (Q^*)^{0.25} \quad (\text{for } Q^* \geq 0.4). \quad \text{-----Eq. 4.31b}$$

For weir-baffle height = $0.1 D$,

$$\frac{Y_p}{D} = 0.46 (Q^*)^{0.25}. \quad \text{-----Eq. 4.33}$$

Calculation Step (4): Calculate dimensionless water velocity (U_*). For weir-baffle height = $0.15 D$,

$$U^* = 2.92 (Q^*)^{0.17} \quad \left[\text{for } 0.15 < \frac{Y_p}{D} < 0.25 \right], \quad \text{-----Eq. 4.32a}$$

$$U^* = 4.3 (Q^*)^{0.41} \quad \left[\text{for } \frac{Y_p}{D} \geq 0.25 \right]. \quad \text{-----Eq. 4.32b}$$

For weir-baffle height = $0.1 D$,

$$U^* = 3.7 (Q^*)^{0.24} \quad \left[\text{for } 0.1 < \frac{Y_p}{D} < 0.35 \right], \quad \text{-----Eq. 4.34a}$$

$$U^* = 4.21 (Q^*)^{0.38} \left[\text{for } \frac{Y_p}{D} \geq 0.35 \right] \quad \text{-----Eq. 4.34b}$$

Calculation Step (5): Calculate water velocity (V_{occ}) over the weir baffle where the fish swim near the culvert wall. For weir-baffle height = $0.15 D$,

$$V_{occ} = 0.6 U^* (g S_o D)^{0.5}. \quad \text{-----Eq. 4.35}$$

For weir-baffle height = $0.1 D$,

$$V_{occ} = 0.8 U^* (g S_o D)^{0.5}. \quad \text{-----Eq. 4.36}$$

Calculation Step (6): Calculate white muscle power necessary for the design fish to swim over each weir baffle.

(a) Calculate the profile drag force (F_D) on the design fish. From Chapter III,

$$F_D = 0.0576 (\rho) (\nu)^{0.2} L^{1.8} V_{fw}^{1.8}. \quad \text{-----Eq. 3.4}$$

Assuming that $L = L_f / 0.92$, and $V_{fw} = (V_{occ} + 1 \text{ ft./sec})$, Equation 3.4 becomes

$$F_D = 0.0576 (\rho) (\nu)^{0.2} \left[\frac{L_f}{0.92} \right]^{1.8} (V_{occ} + 1 \text{ ft./sec})^{1.8}. \quad \text{-----Eq. 5.29}$$

(b) Calculate the gradient force (F_G) on the design fish. Referring again to Chapter III,

$$F_G = 0.009 \gamma (L_f)^3 (S_o). \quad \text{-----Eq. 3.9a}$$

(c) Using the results of steps (a) and (b), calculate the power (P_{weir}) which the design fish must produce if it is to move upstream over a typical weir baffle. Utilizing Equation 3.15,

$$P = (F_D + F_G + F_{vm}) (V_{fw}). \quad \text{-----Eq. 3.15}$$

For the streaming flow assumed over the weir baffles, there is little water acceleration at the baffle, so Equation 3.15 becomes

$$P_{weir} = (F_D + F_G) (V_{occ} + 1 \text{ ft/sec}). \quad \text{-----Eq. 5.30}$$

Decision Point (1): If $P_{cw} \geq P_{weir}$ then the design is acceptable *for fish passage*. If the outlet conditions provide for $TW \geq Y_p$, GOTO Calculation Step (7), ELSE IF baffle height = $0.1 D$ then GOTO Input Step (2), increase baffle height to $0.15 D$, and repeat the procedure to Decision Point (1), ELSE GOTO Input Step (2), increase D , and repeat the procedure.

Calculation Step (7):

(a) Using the Manning equation for the design-flood flow, calculate the normal depth of flow (y_n) for the trial culvert in the absence of weir baffles.

(b) Calculate the increase in depth of flow due to the presence of weir baffles. From Chapter IV, for weir-baffle height = $0.15 D$,

$$\frac{\Delta y}{Y_n} = 0.75 Q_*^{-0.42}, \quad \text{-----Eq. 4.37}$$

and for weir-baffle height = $0.1 D$,

$$\frac{\Delta y}{Y_n} = 0.57 Q_*^{-0.48}. \quad \text{-----Eq. 4.38}$$

Decision Point (2): If $(\Delta y + y_n) > 0.9 D$, then a larger trial culvert diameter must be assumed and GOTO Computation Step (2), else the design is acceptable for both fish passage and design-flood flows.

Calculation Step (8): Calculate number (N) of weir baffles necessary for the culvert.

$$N = \frac{L_c}{0.6 D}$$

-----Eq. 5.31

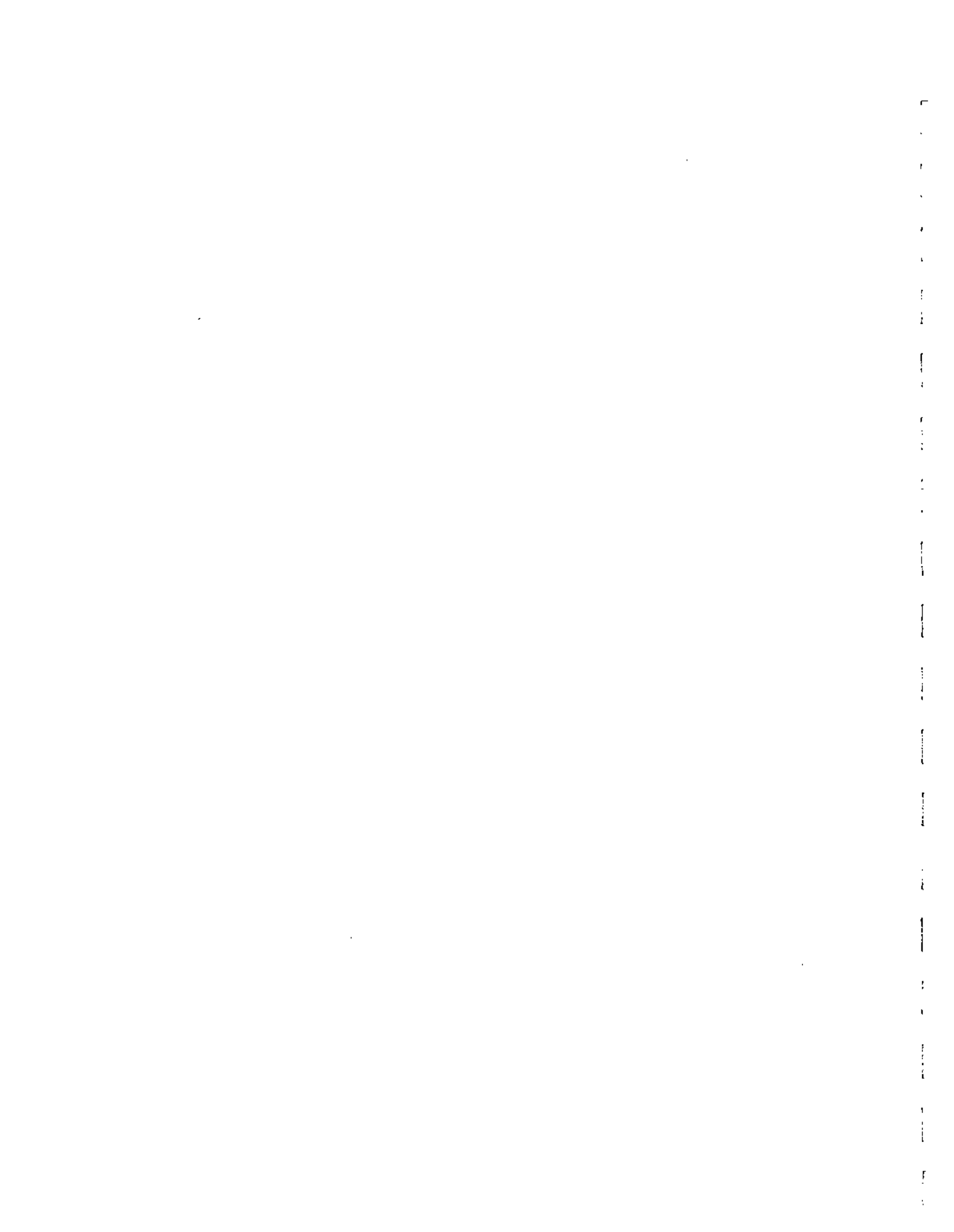

VI. RETROFITTING FOR FISH PASSAGE

Chapter Summary:

This chapter discusses the principles of culvert retrofitting for fish passage. Problem identification is set forth. Barrel retrofitting with bed material collectors to create artificially depressed inverts and the use of weir baffles to slow water velocities are considered in detail. Outlet and inlet problems and their solutions are detailed.

VI.A. Overview

Retrofitting is defined as modifying an existing culvert to facilitate fish passage. Though not all culverts can be retrofitted, where it is feasible, it can be a cost-effective alternative to total replacement.

The need to retrofit a culvert for fish passage results from at least one of three related fundamental problems: (1) the culvert outlet is perched or partially perched, so fish cannot enter the culvert, (2) the culvert has too much slope, so water velocities are too great for fish to negotiate the outlet, barrel, and/or inlet, and (3) the culvert corrugations are so small that a proper boundary effect does not exist for fish passage at flow Q_f or less. For retrofitting, the design engineer must first identify which of these specific hydraulic problems exist.

Unlike a new culvert design, a retrofit design must be performed without the freedom to select the cross-sectional size and shape of the culvert or to stipulate specific corrugation sizing. Additionally, the vertical placement of the culvert is fixed, so the designer cannot

“tune” that element of the design. The road embankment is already in place, so its stability may not be designed to withstand possible new hydraulic conditions. Thus, the designer’s choice of options may be rather limited.

The existing culvert’s performance history has probably been documented. Thus, the magnitude of Q_f may be known indirectly through memories of locals, written documents, or observable high-water marks, or directly through stream gaging records. A better estimate of the design flood may also be available. In addition, culvert outlet scour pools may be well established and stable.

The objective of passing a specific percentage of design fish at a flow of Q_f is the same for retrofitting a culvert as for new culvert design. Meeting that objective may simply not be possible. The design engineer may have to settle for whatever segment, if any, of the prospective fish run retrofitting techniques will allow.

The initial problem in a retrofit design is discovering why fish are unable to ascend the problem culvert. Visual observations during times when desired fish passage flows exist can definitely determine if the culvert is perched or partially perched. If the culvert is perched, outlet problems certainly exist for Class-I fish. If it is partially perched, outlet problems may exist. Barrel and inlet problems are often better identified through computational methods.

Existing and potential problems must be identified. For example, fish may not be entering a perched culvert outlet (obvious existing problem), but when the outlet problem is solved,

they may then not be capable of negotiating the culvert barrel (not-so-obvious potential problem). Problems are generally identified in the upstream direction beginning at the outlet. However, if the solution to a barrel problem requires the introduction of a bedload collector to create an artificially depressed invert, weir baffles, or any other of the improvements considered in Chapter IV, a previously non-existent outlet problem may be created.

VI.B. Design of Culvert Retrofits

The design process consists of:

- (1) Identifying design fish, desired fish passage discharge (Q_p), and the existing culvert and site geometry and hydraulic conditions of outlet, barrel, and inlet.
- (2) Testing existing hydraulic conditions against fish passage criteria to determine where the hydraulic problem exists.
- (3) Making whatever hydraulic changes are warranted and possible to allow fish passage.

Mitigation procedures may involve improving the rating curve for the culvert outlet pool if only outlet problems exist. If the problem is in the barrel, an artificially depressed invert or baffling of some sort must be introduced to provide passage and resting locations compatible with the design fish's capabilities. Changing the barrel increases the depth of flow in the culvert and will probably require raising the outlet pool rating curve. Baffling can consist of one of the methods outlined in Chapter IV. The writers suggest the following sequence of possible solutions for barrel problems:

- (1) The Montana bedload collector to achieve an artificial depression of the invert.

(2) Weir baffles of the types indicated in Chapter IV.

(3) Canadian offset baffles. These should be used only for very specialized situations as they are more expensive than the other alternatives.

Computationally, these alternatives have relatively predictable hydraulic results. However, discrete rip-rap insertions, described in Chapter IV, have been successful in at least one culvert in Alaska, and could be considered as a trial choice. Though their results cannot be predicted computationally, they are inexpensive, and little is lost if they do not affect fish passage.

If only inlet problems exist, it may be possible to change the inlet geometry to solve the problem. However, the solution of outlet problems usually changes the hydraulics of the barrel but with positive results. Improvements which extend through the barrel usually also improve inlet conditions.

Design of a new culvert for fish passage begins with a desired fish passage flow, and the culvert is designed to pass fish at that flow. Retrofitting, on the other hand, begins with an existing culvert. The actual maximum flow at which the design fish can pass through the culvert is determined for whatever retrofit options are considered. This may be different from Q_f , but, for the best retrofit option, this is all that be accomplished with a retrofit. If more is necessary, the existing culvert must be replaced with a suitable new structure.

The design procedures consist of the following steps:

(1) Input the existing culvert and fish parameters. These are design fish fork length (L_f), culvert length (L_c), maximum slope of the existing culvert (S_o) (because of possible sag, this may be greater than the average slope of the culvert), culvert diameter (D), Manning n for culvert walls (n_c), Manning n for bed material of the stream (n_b) (if an artificially depressed invert is to be utilized), desired fish passage flow (Q_f), and the outlet pool rating curve for flows up to Q_f .

(2) Calculate the average water velocity (V_{avef}) which the design fish is capable of swimming against while passing through the culvert (slope S_o). V_{occ} is assumed to be $0.4 V_{avef}$, and the design fish is assumed to move with velocity (V_f) of 0.1 ft/sec relative to the culvert. If culvert corrugations are smaller than 1-1/4 inch in height, the writers suggest increasing V_{occ} to $0.6 V_{avef}$. This is a relatively arbitrary suggestion not substantiated with data, but it appears prudent.

(3) For a range of flows in the unimproved culvert from zero to desired Q_f , calculate and plot (against Q as an independent variable) the normal depth of flow (y_n), critical depth of flow (y_c), the depth of flow required for safe flow velocity (y_{avef}), and outlet pool tailwater elevation (TW).

(4) If the tailwater elevation (TW) $\geq y_{avef}$, then there is no *outlet* problem under the *existing* conditions. If $y_n \geq y_{avef}$ for all Q 's up to Q_f , no *barrel* problem exists. If tailwater and barrel problems do not exist, the problem with fish passage occurs at the inlet. In this

case, the problem might be obviated by a change in inlet geometry. Otherwise, barrel and/or outlet conditions may have to be changed.

(5) If, from step (4), $y_n < y_{avef}$ for all discharges up to Q_f , the barrel does not allow fish passage for those flows where $y_n < y_{avef}$, and additional roughness in the form of an artificial depression or baffles of some sort must be designed to make the barrel acceptable.

(6) Following resolution of any barrel problems, the outlet must be checked to determine if it allows fish passage. If it does not, the outlet pool control must be altered to allow for proper outlet conditions. If no barrel changes are warranted, but the outlet does not function properly, the outlet control must be altered to improve the outlet conditions (increase TW).

(7) Check the inlet. If it does not allow fish passage, it must be redesigned. If changes in inlet geometry are not sufficient, relatively major changes may be required to solve the inlet problem. Such changes may or may not be reasonable. The designer must remember that not every culvert can be retrofitted for fish passage. Some of those which cannot be retrofitted to pass the design fish at flow Q_f might be retrofitted for successful passage of design fish at lesser discharges.

The use and value of the $y_{avef}-Q$, y_n-Q , y_c-Q , and $TW-Q$ curves of step (3) require explanation. These curves should be drawn using data from the culvert invert at the outlet lip. (That shown in Figure VI-1 is one of many possibilities for such curve sets.) For fish

to pass through the culvert barrel, the depth of flow in the culvert at any fish passage Q must be $\geq y_{avef}$ for that discharge. If y_{avef} in the culvert is greater than y_n , water velocities are too great for fish passage *unless* outlet conditions are such that backwater into the culvert forces $y \geq y_{avef}$ everywhere in the culvert. If $y_n > y_c$, then the culvert barrel is always safe if

$$TW = Y_o = y_{avef} + S_o L_c \quad \text{---Eq. 6.1}$$

for the specific discharge and culvert configuration (Y_o is the outlet depth of the culvert). For long culverts this is a difficult way to improve barrel conditions since the term $S_o L_c$ may be considerable.

If $y_n > y_c$ the backwater curve generated by making TW (and thus Y_o) $> y_n$ is an M-1 curve. The effect of the backwater curve is shown in Figure VI-2. Clearly, when the outlet depth is given by Equation 6.1, the effect of the M-1 curve is to make water depths somewhat greater than y_{avef} everywhere in the culvert.

The relationship between the y_c - Q curve and the y_n - Q curve determines if supercritical flow can be expected in the culvert for any discharge of importance. Supercritical flow creates difficult-to-predict wave patterns which, in turn, result in unpredictable depths of flow at

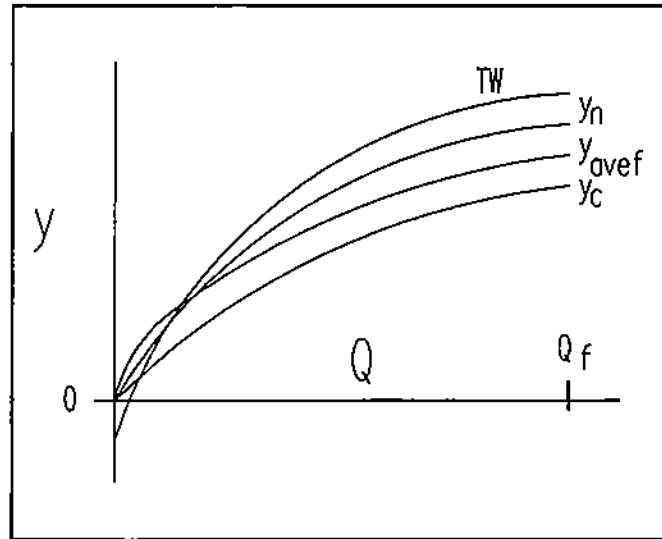

Figure VI-1. Example of set of y - Q curves for analysis of barrel and outlet.

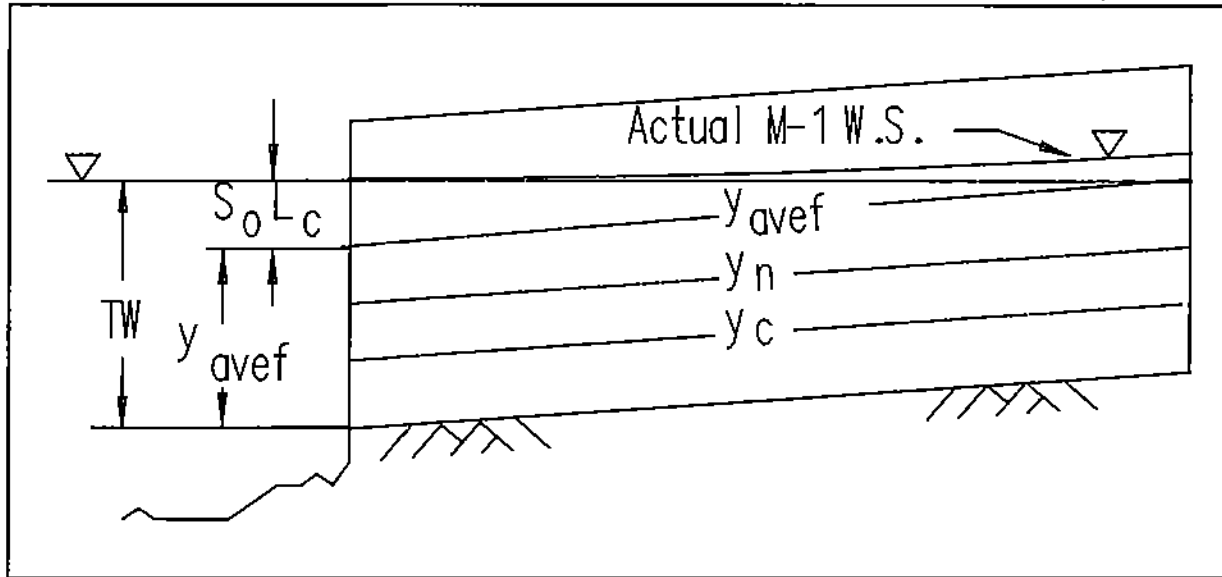

Figure VI-2. Safe TW elevation when safe fish passage water depth is less than normal depth, and normal depth is greater than critical depth. M-1 water surface profile provides some safety factor.

various locations in the culvert. For this and other reasons discussed in Chapter IV, it is better if $y_c < y_n$ everywhere in the culvert for all fish passage Q 's. If culvert sag exists, the design engineer must be especially certain that $y_c < y_n$ at that location in the culvert where the slope is greatest. This may be a problem if a culvert barrel is retrofitted by creating an artificially depressed invert and that depression uniformly follows the sag in the culvert.

For any Q , if $TW < y_c$, then the outlet conditions probably are too difficult for fish passage. (This is not necessarily true for small values of y_c .) If $y_c < TW < y_{avef}$, then outlet conditions might be too difficult for fish passage. An outlet analysis for specific flow conditions, similar to that for new culvert design (Chapter V), must be made to resolve this question.

VI.B.1.a. Specific Retrofit Design Steps

Input Step (1): Input parameters which are fixed for the culvert design.

(a) Input culvert length (L_c), culvert diameter (D), invert depression depth (d) (if it exists), Manning n of culvert corrugations (n_c), Manning n of bedload material (n_b), design fish fork length (L_f), maximum slope in existing culvert (S_o), and desired fish passage design flow (Q_f).

(b) Using the culvert outlet invert elevation as the basis of TW , prepare an outlet pool rating curve for Q 's $\leq Q_f$. The rating curve is determined separately using techniques from "Hydraulic Design Series No. 8, Culvert Analysis, Microcomputer Programs Applications Guide (and software)" (1987). However, to be compatible with other y - Q curves, TW must have the same basis as the others, i.e., the culvert outlet invert. This means TW may have a positive, negative, or zero value for $Q = 0$.

Calculation Step (1): Calculate design fish's red muscle power capabilities (P_r) for the time the fish is in the culvert.

(a) Determine time (t) required for fish to pass through culvert. V_f is assumed to be 0.1 ft/sec for Class-I fish, so

$$t = \frac{L_c}{V_f} = \frac{L_c}{0.1}. \quad \text{-----Eq. 5.1}$$

(b) From Chapter III, design fish total length (L) is assumed to be

$$L = \frac{L_f}{0.92}. \quad \text{-----Eq. 5.2}$$

(c) Fish red muscle power *capability* (assuming profile drag only) is

$$\begin{aligned}
 V_{fvc} &= \text{Eq. 3.13b}, \\
 &= 6.98 L^{0.55} t^{-0.08}, \\
 &= 6.98 (\text{Eq. 5.2})^{0.55} (\text{Eq. 5.1})^{-0.08}.
 \end{aligned}
 \tag{-----Eq. 5.3}$$

$$\begin{aligned}
 F_{Dc} &= \text{Eq. 3.4}, \\
 &= 0.0576 (\rho) (\nu)^{0.2} L^{1.8} V_{fvc}^{1.8}, \\
 &= 0.0576 \rho \nu^{0.2} L^{1.8} (6.98 L^{0.55} t^{-0.08})^{1.8}, \\
 &= 0.0576 \rho \nu^{0.2} (\text{Eq. 5.2})^{1.8} (\text{Eq. 5.3})^{1.8}.
 \end{aligned}
 \tag{-----Eq. 5.4}$$

$$\begin{aligned}
 P_c &= F_{Dc} V_{fvc}, \\
 &= 0.0576 \rho \nu^{0.2} L^{1.8} V_{fvc}^{2.8}, \\
 &= 0.0576 \rho \nu^{0.2} (\text{Eq. 5.2})^{1.8} (\text{Eq. 5.3})^{2.8}.
 \end{aligned}
 \tag{-----Eq. 5.5}$$

Where V_{fvc} is the V_{fv} which the fish is *capable* of achieving in the absence of gradient and virtual mass force, F_{Dc} is the profile drag force which the fish is *capable* of achieving in absence of other forces, and P_c is the power which a fish of length L is *capable* of delivering for period t .

Calculation Step (2): Calculate maximum culvert V_{avef} which will allow design fish passage for this culvert L_c and S_o .

(a) Equate fish power capability (P_c) with necessary output (P).

$$\begin{aligned}
 P_c &= \text{Eq. 5.5}, \\
 P &= \text{Eq. 3.15} = (F_D + F_G) V_{fv} \quad (\text{ignoring } F_{vm}), \\
 \text{Eq. 5.5} &= (\text{Eq. 3.4} + \text{Eq. 3.9a}) V_{fv}.
 \end{aligned}
 \tag{-----Eq. 5.6}$$

Equation 5.6 is solved for V_{fv} by trial-and-error. This V_{fv} is the V_{occ} which the design fish can sustain in the culvert barrel set at the slope S_o . It is less than V_{fvc} calculated by Equation 5.3 which was for $S_o = 0$.

(b) Calculate V_{avef} from V_{fv} and V_{occ} .

$$V_{fv} \text{ (as calculated from Eq. 5.6)} = V_{occ} \quad \text{-----Eq. 5.7}$$

$$V_{avef} = \frac{V_{occ}}{0.4} \quad \text{(from Chapter IV).}$$

If existing culvert corrugation height is less than 1¼ inch,

$$V_{avef} = \frac{V_{occ}}{0.6} \quad \text{-----Eq. 6.1}$$

Calculation Step (3): Calculate acceptable fish passage depths of flow (y_{avef}) for several Q 's $\leq Q_f$.

(a) For each Q , V_{avef} , as determined in Calculation Step (2), remains constant.

Calculate y_{avef} for each of the Q 's. This is the depth at which $V_{ave} = V_{avef}$.

(b) Superpose a plot of the y_{avef} - Q curve on the TW - Q curve of Input Step (1)(b).

Calculation Step (4): Calculate normal depth (y_n) and critical depth (y_c) for several Q 's $\leq Q_f$.

(a) Calculate y_n for these Q 's by trial-and-error solution of the Manning equation for uniform open channel flow.

$$Q = \left[\frac{1.49}{n} \right] A_n R_n^{2/3} S_o^{1/2}, \quad \text{-----Eq. 5.8}$$

where A_n and R_n are the cross-sectional area of flow and the hydraulic radius, respectively, at normal depth, and n is a composite of culvert sides and bottom material depending on use of depressed invert. y_n is found by trial and error solution of Equation 5.8.

(b) Calculate critical depth by trial-and-error solution of Equation 4.1 for $Q = Q_f$ and smaller Q 's of preceding step (a):

$$\frac{Q_f^2 B_c}{g A_c^3} = 1, \quad \text{-----Eq. 4.1}$$

where B_c and A_c are water surface width and cross-sectional area of flow, respectively, at critical depth. y_c is found by trial-and-error solution of Equation 4.1.

(c) Superpose plots of y_n - Q and y_c - Q on the previous plots of TW - Q and y_{avef} - Q from Input Step (1)(b) and Calculation Step (3).

Decision Point (1): If $y_n < y_{avef}$ for any $Q \leq Q_f$, then culvert barrel does not support fish passage of the design fish at that flow. GOTO Calculation Step (2.1), ELSE

Decision Point (2): Caution regarding possible supercritical flow. If $y_c > y_n$ for any $Q \leq Q_f$, then supercritical flow exists in the culvert for those Q 's, and M-type backwater curves are *not* representative of this flow. Continue.

Calculation Step (5): Calculate effects on fish passage of possible inlet geometry improvements, i.e., the addition of a flush headwall and of a bevelled headwall at the inlet. For this y_n only Q_f is used as the depth of flow in the culvert at the downstream end of the

inlet zone, and the methods of Chapter V.B.3.a are used to determine if the inlet is acceptable for fish passage. (Those methods are not repeated here.)

Decision Point (3): If the improved inlet from Calculation Step (5) does not make the culvert acceptable for fish passage, then GOTO Calculation Step (2.1), else

Decision Point (4): Check for possible outlet problems. If $TW \geq y_{avef}$ for all $Q \leq Q_f$, culvert design is acceptable for passage of the design fish, ELSE an outlet problem exists.

Calculation Step (6): Design suitable outlet pool control to make $TW \geq y_{avef}$ for all Q 's $\leq Q_f$. If this is achieved, fish passage will probably follow.

Decision Point (5): If Calculation Step (6) is not successful, but fish passage at some level is desired from the culvert, reduce Q_f and GOTO Calculation Step (3), ELSE IF Calculation Step (6) is successful,

Calculation Step (7): Check retrofit for passage of design flood. For design flood Q , if $d = 0$, check for flood passage by normal culvert design methods, or if $d > 0$, check for flood passage by methods of Chapter V which accommodate depressed invert culvert calculations.

Calculation Step (2.1): Increase the culvert depression depth (d) by 1 ft.

Decision Point (2.1): If d appears to be reasonable, GOTO Calculation Step (3), ELSE

Calculation Step (3.1): Begin weir baffle investigation. Calculate design fish's white muscle power capabilities (P_{cv}). From Equation 5.21,

$$P_{cv} = 4 \left[\frac{L_f}{240} \right]^{2.46} \quad \text{-----Eq. 5.28}$$

Calculation Step (3.2): Calculate the dimensionless discharge Q_* . (Equations are from Chapter IV.)

$$Q_* = \frac{Q_f}{(g S_o D^5)^{0.5}} \quad \text{-----Eq. 4.12}$$

Calculation Step (3.3): Calculate dimensionless depth at the weir baffle (Y_p/D). For weir-baffle height = 0.15 D ,

$$\frac{Y_p}{D} = 0.41 (Q_*)^{0.202} \quad (\text{for } Q_* < 0.4), \quad \text{-----Eq. 4.31a}$$

$$\frac{Y_p}{D} = 0.5 (Q_*)^{0.25} \quad (\text{for } Q_* \geq 0.4). \quad \text{-----Eq. 4.31b}$$

For weir-baffle height = 0.1 D ,

$$\frac{Y_p}{D} = 0.46 (Q_*)^{0.25}. \quad \text{-----Eq. 4.33}$$

Calculation Step (3.4): Calculate dimensionless water velocity (U_*). For weir-baffle

height = $0.15 D$,

$$U_* = 2.92 (Q_*)^{0.17} \left[\text{for } 0.15 < \frac{Y_p}{D} < 0.25 \right], \quad \text{-----Eq. 4.32a}$$

$$U_* = 4.3 (Q_*)^{0.41} \left[\text{for } \frac{Y_p}{D} \geq 0.25 \right]. \quad \text{-----Eq. 4.32b}$$

For weir-baffle height = $0.1 D$,

$$U_* = 3.7 (Q_*)^{0.24} \left[\text{for } 0.1 < \frac{Y_p}{D} < 0.35 \right], \quad \text{-----Eq. 4.34a}$$

$$U_* = 4.21 (Q_*)^{0.38} \left[\text{for } \frac{Y_p}{D} \geq 0.35 \right]. \quad \text{-----Eq. 4.34b}$$

Calculation Step (3.5): Calculate water velocity (V_{occ}) over the weir baffle where the fish swim near the culvert wall. For weir-baffle height = $0.15 D$,

$$V_{occ} = 0.6 U_* (g S_o D)^{0.5}. \quad \text{-----Eq. 4.35}$$

For weir-baffle height = $0.1 D$,

$$V_{occ} = 0.8 U_* (g S_o D)^{0.5}. \quad \text{-----Eq. 4.36}$$

Calculation Step (3.6): Calculate white muscle power necessary for the design fish to swim over each weir baffle.

(a) Calculate the profile drag force (F_D) on the design fish. From Chapter III,

$$F_D = 0.0576 (\rho) (\nu)^{0.2} L^{1.8} V_{fw}^{1.8} \quad \text{-----Eq. 3.4}$$

Assuming that $L = L_f/0.92$ and $V_{fw} = (V_{occ} + 1 \text{ ft/sec})$, Equation 3.4 becomes

$$F_D = 0.0576 (\rho) (\nu)^{0.2} \left[\frac{L_f}{0.92} \right]^{1.8} (V_{occ} + 1 \text{ ft/sec})^{1.8} \quad \text{-----Eq. 5.29}$$

(b) Calculate the gradient force (F_G) on the design fish. Referring again to Chapter III,

$$F_G = 0.009 \gamma (L_f)^3 (S_o) \quad \text{-----Eq. 3.9a}$$

(c) Using the results of steps (a) and (b), calculate the power (P_{weir}) the design fish must deliver if it is to move upstream over a typical weir baffle. Utilizing Equation 3.15,

$$P = (F_D + F_G + F_{vm}) (V_{fw}) \quad \text{-----Eq. 3.15}$$

For the streaming flow assumed over the weir baffles, there is little water acceleration at the baffle, so Equation 3.15 becomes

$$P_{weir} = (F_D + F_G) (V_{occ} + 1 \text{ ft/s}) \quad \text{-----Eq. 5.30}$$

Decision Point (3.1): If $P_{cw} \geq P_{weir}$, the weir-baffle design of the barrel is acceptable for fish passage GOTO Calculation Step (3.7), ELSE

Decision Point (3.2): If smaller Q 's than Q_f are acceptable for fish passage, then reduce Q_f by 10% and GOTO Calculation Step (3.1), else abandon retrofitting.

Calculation Step (3.7): Check for passage of design flood.

(a) Using the Manning equation for the design-flood flow calculate the normal depth of flow (y_n) for the trial culvert in the absence of weir baffles.

(b) Calculate the increase in depth of flow due to the presence of weir baffles. From Chapter IV, for weir-baffle height = $0.15 D$,

$$\frac{\Delta y}{y_n} = 0.75 Q_*^{-0.42}, \quad \text{-----Eq. 4.37}$$

and for weir-baffle height = $0.1 D$,

$$\frac{\Delta y}{y_n} = 0.57 Q_*^{-0.48}. \quad \text{-----Eq. 4.38}$$

Decision Point (3.2): If $(\Delta y + y_n) > 0.9 D$, then weir baffles should not be used, and the culvert cannot be retrofitted, else the barrel retrofit design is acceptable for both fish passage and design-flood flows.

Calculation Step (3.8): Calculate number of weir baffles necessary for the culvert.

$$N = \frac{L_c}{0.6 D}. \quad \text{-----Eq. 5.31}$$

Decision Point (3.3): Check outlet conditions. If $TW \geq Y_p$, then outlet conditions are acceptable for fish passage, else

Calculation Step (3.9): Outlet pool control must be improved to raise outlet pool to achieve $TW = Y_p$ for flow Q_f . When this is achieved, the weir-baffle retrofit design is complete.

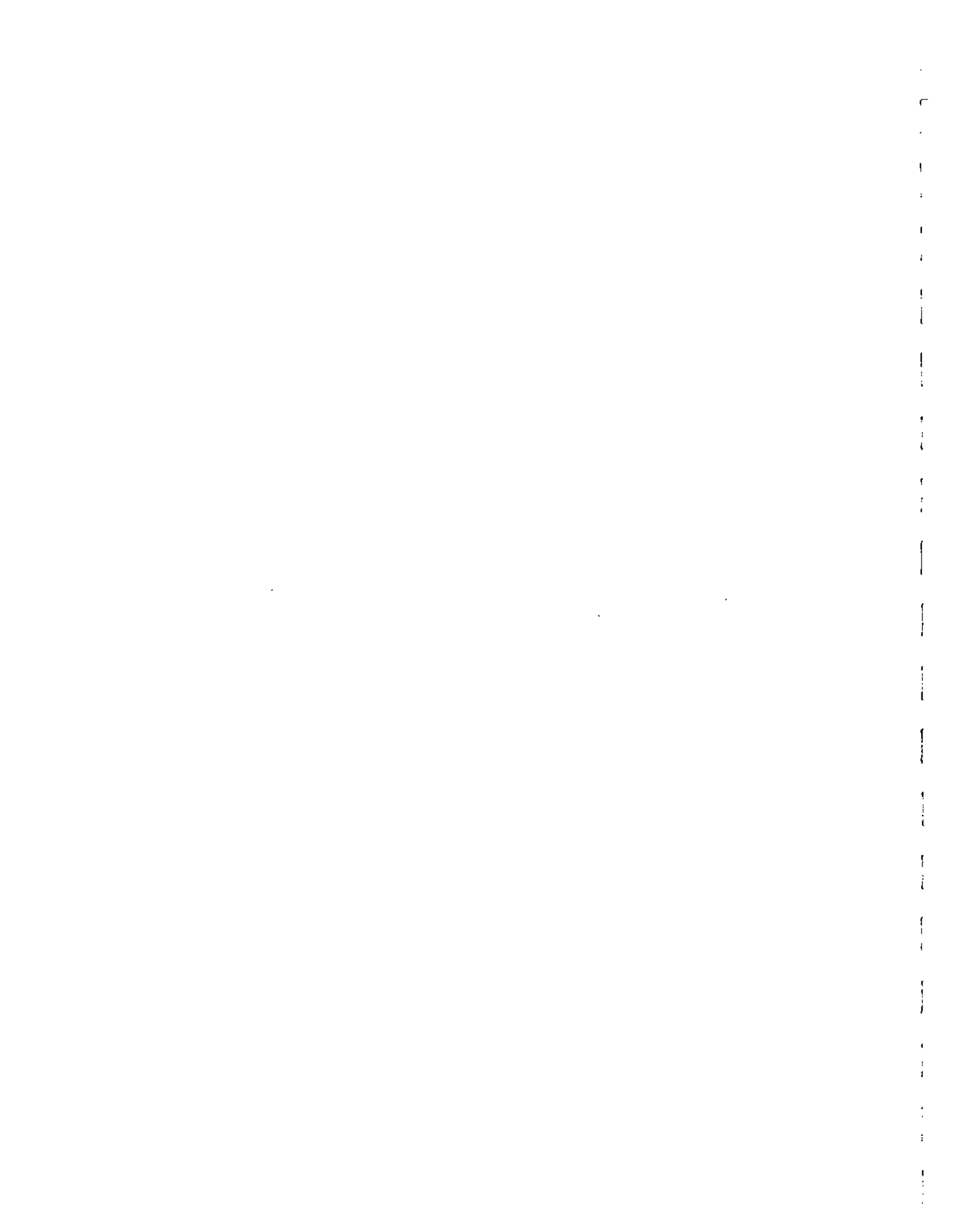

VIII. BIBLIOGRAPHY

- "Hydraulic Design of Energy Dissipators for Culverts and Channels," 1983. U.S. Department of Transportation, Federal Highway Administration, Hydraulic Engineering Circular No. 14, prepared by Corry, M.L., Thompson, P.L., Watts, F.J., Jones, J.S., and Richards, D.L.
- "Hydraulic Design of Highway Culverts," 1985. U.S. Dept. of Transportation, Federal Highway Administration, Hydraulic Design Series No. 5, Rpt. No. FHWA-IP-85-15, Sept. 1985. (HDS5).
- "Hydraulic Design Series No. 8, Culvert Analysis, Microcomputer Programs Applications Guide (and software)," 1987. U.S. Department of Transportation, Federal Highway Administration, Rpt. No. FHW-ED-87-101. (HY8).
- Arctic Hydrologic Consultants, 1985. Discharge velocities in culverts that ensure passage of Arctic grayling, *Thymallus arcticus*. Prepared under contract for the Alaska Department of Fish and Game, Fairbanks, Alaska, 35 pg.
- Bainbridge, R., 1960. "Speed and stamina in three fish." J. Exptl. Biol., 37(1):129-153.
- Beamish, F.W.H., 1978. "Swimming capacity. In: Fish Physiology." Vol. VII. Locomotion. Hoar, W.S. and Randall, D.J., (eds). Academic Press, New York. pp. 101-187.
- Beamish, F.W.H., 1980. "Swimming performance and oxygen consumption of the charrs." pp. 739-748. In: Balon, E.K. (ed.) "Charrs, Salmonid Fishes of the Genus Salvelinus." Junk, W., The Hague. The Netherlands.
- Behlke, C.E., 1987. "Hydraulic relationship between swimming fish and water flowing in culverts." Proceedings of Second International Cold Regions Environmental Engineering Conference, Edmonton, Alberta.
- Behlke, C.E., 1988. "Hydraulic effects on fish swimming in fish passage structures." A.S.C.E. National Hydraulics Specialty Conference, Colorado Springs, Colorado, August 1988.
- Behlke, C.E., 1991. "Power and energy implications of passage structures to fish." Paper presented at A.F.S. Fisheries Engineering Conference, Portland, Oregon, October 1988. (3/91, This paper has been reviewed and is in the process of being published by A.F.S.)

- Behlke, C.E., Kane, D.L., McLean, R.F., and Travis, M.D., 1988. "Spawning migration of Arctic Grayling through Poplar Grove Creek culvert, Glennallen, Alaska, 1986." State of Alaska Dept of Transportation and Pub. Fac. for the Federal Highway Admin., Report No. FHWA-AK-RD-88-03.
- Behlke, C.E., Kane, D.L., McLean, R.F., and Travis, M.D., 1989. "Field Observations of Arctic Grayling Passage through Highway Culverts." Transportation Research Board, National Research Council, Transportation Research Record 1224, Washington, D.C. 1989.
- Bell, Milo C., 1985. "Fisheries Handbook of Engineering Requirements and Biological Criteria." Fish Passage Dev. and Eval. Program, Corps of Eng, N P Div, Portland, Oregon.
- Blake, R.W., 1983. "Fish Locomotion." Cambridge University Press, Cambridge, England.
- Blaxter, J.H.S., 1969. Swimming Speeds of Fish. FAO Fish Report, 62, Vol. 2: 69-100.
- Brett, J.R., 1963. "The Energy Required for Swimming by Young Sockeye Salmon with a Comparison of the Drag Force on a Dead Fish." Transactions of the Royal Society of Canada, Vol. 1, Series IV, June 1963, pp 441-457.
- Brett, J.R., 1964. "The respiratory metabolism and swimming performance of young sockeye salmon." J. Fish. Res. Board Canada, 21(5):1183-1226.
- Brett, J.R., 1965a. "The swimming energetics of salmon." Scientific American, 213:80-85.
- Brett, J.R., 1965b. "The relation of size to the rate of oxygen consumption and sustained swimming speed of sockeye salmon (Oncorhynchus nerka)." J. Fish. Res. Board of Canada, 22(6):1491-1501.
- Brett, J.R., 1967. "Swimming performance of sockeye salmon (Oncorhynchus nerka) in relation to fatigue time and temperature." J. Fish. Res. Board of Canada, 24(8):1731-1741.
- Brett, J.R., 1982. "The swimming speed of adult pink salmon, Oncorhynchus gorbuscha, at 20°C and a comparison with sockeye salmon O. nerka." Can. Tech. Rep. Fish. Aquat. Sci. 1143:1-37.
- Brett, J.R., and Glass, N.R., 1973. "Metabolic rates and critical swimming speeds of sockeye salmon (Oncorhynchus nerka) in relation to size and temperature." J. Fish. Res. Board Canada, 30:379-387.
- Carlson, R.F., and Blevins, V., 1989. Unpublished laboratory study of Stixkwan Creek, Denali Highway, Alaska.

- Chow, V.T., 1959. *Open Channel Hydraulics*. McGraw-Hill, Inc., New York.
- Clancy, C.G., and Reichmuth, D.R., 1990. "A detachable fishway for steep culverts." *North American J. of Fisheries Management* 10:244-246, 1990.
- Dahlberg, M.L., Shumway, D.L., and Doudoroff, P., 1968. "Influence of dissolved oxygen and carbon dioxide on swimming performance of largemouth bass and coho salmon." *J. Fish. Res. Board of Canada*, 25:49-70.
- Dane, B.G., 1978. "A review and resolution of fish passage problems at culvert sites in British Columbia, Department of Fisheries and Environment Canada, Pacific Region," Fisheries and Marine Service, Vancouver, B.C., September 1978.
- Davis, G.E., Foster, J., Warren, C.E., and Doudoroff, P., 1963. "The influence of oxygen concentration on the swimming performance of juvenile Pacific salmon at various temperatures." *Trans. Am. Fish. Soc.*, 92:111-124.
- Engle, P., 1974. "Fish passage facilities for culverts of the McKenzie Highway." Canada Centre for Inland Waters, Burlington, Ontario, Canada.
- Fisher, J.G., and Tack, S.L., 1977. "Performance of Arctic Grayling in a twenty foot section of Model "A" Alaska steeppass fish ladder." Final Rpt. to the Army Corps of Engrs., Alaska Div., Anchorage, AK.
- Flagg, T.A., Prentice, E.F., and Smith, L.S., 1983. "Swimming stamina and survival following direct seawater entry during parr-smolt transformation of coho salmon (*Oncorhynchus kisutch*)." *Aquaculture*, 32:383-396.
- Fleming, D.F., 1989. "Effects of Spawning Run Delay on Spawning Migration of Arctic Grayling." Alaska Cooperative Fishery Research Unit, Unit Contribution No. 29, Univ. of Alaska, Fairbanks.
- Fry, F.W.J., and Cox, E.T., 1970. "A relation of size to swimming speed in rainbow trout." *J. Fish. Res. Board of Canada*, 27:976-978.
- Glova, G.J. and McInerny, J.E., 1977. "Critical swimming speeds of coho salmon (*Oncorhynchus kisutch*) fry to smolt stages in relation to salinity and temperature." *J. Fish. Res. Board of Canada*, 34:151-154.
- Howard, T.E., 1975. "Swimming performance of juvenile coho salmon (*Oncorhynchus kisutch*) exposed to bleached kraft pulpmill effluent." *J. Fish. Res. Board of Canada*, 32:789-793.
- Hunter, L.A., and Mayor, L., 1986. "Analysis of fish swimming performance data," North-South consultants report for Dept. of Fisheries and Oceans, Govt. of Canada, and Alberta Dept. of Transportation.

- Jones, D.R., Kiceniuk, J.W., and Bamford O.S., 1974. "Evaluation of the swimming performance of several fish species from the Mackenzie River," *Journal. of Fish. Res. Bd. Can.* 31:1641-1647.
- Kane, D.L.; Behlke, C.E., Basketfield, D.L., Gieck, R.E., McLean, R.F., and Travis, M.D. 1989. "Hydrology, Hydraulics and Fish Passage Performance of Arctic Grayling (THYMALLUS ARCTICUS) at Fish Creek, Denali Highway near Cantwell, Alaska." Alaska Department of Transportation & Public Facilities, Report FHWA-AH-89-03.
- Katopodis, C., Lodewyk, S., and Rajaratnam, N., 1987. "An experimental study of offset baffle culvert fishways." Technical Report (WRE 87-2), Dept. Civil Engr, Univ. of Alberta, Edmonton, Alberta, Canada.
- Katopodis, C., and Rajaratnam, N., 1989. "An Experimental Study of Weir Baffle Culvert Fishways." Technical Report (WRE-89-3), Department of Civil Engineering, University of Alberta, Edmonton, Alberta, Canada T6G 2G7.
- Katopodis, C., Robinson, P.R., and Sutherland, B.G., 1978. "A study of model and prototype culvert baffling." *Can. Fish. Mar. Serv. Tech. Rep.* 828: v + 78 p.
- Lighthill, M.J., 1971. "Large-amplitude elongation-body theory of fish locomotion." *Proc. R. Soc. Lond.* 179B;125-138. Reprinted as part of Lighthill, M.J., 1975. *Mathematical Biofluidynamics*. Society for Industrial and Applied Mathematics, Philadelphia, PA.
- MacPhee, C., and Watts, F.J., 1976. "Swimming performance of Arctic Grayling in fishway culverts." Final Proj. Rpt., to USFWS, Anchorage, AK, 41 p.
- Orsborn, J.F., and Powers, P.D., 1985. "Fishways—an Assessment of Their Development and Design." Part 3 of 4, Report to the Bonneville Power Administration, Project 82-14, 161 p.
- Peterson, R.H., 1974. "Influence of fenitrothion in swimming velocities of brook trout (Salvelinus fontinalis)." *J. Fish. Res. Board of Canada*, 31:1757-1762.
- Roberson, J.A., Cassidy, J.J., and Chaudhry, M.H., 1988. *Hydraulic Engineering*. Houghton Mifflin Company, Boston, Mass.
- Rouse, Hunter, 1938. *Fluid Mechanics for Hydraulic Engineers*. Engineering Societies Monographs, 1st ed. McGraw Hill Book Co., New York, NY, 415 p.
- Simons, D.B., Stevens, M.A., Watts, F.J., 1970. Flood Protection at Culvert Outlets, Colorado State University, Fort Collins, Colorado, CER 69-70 DBS-MAS-FJW4.
- Tilsworth, T., and Travis, Michael D., 1987. "Fish passage through Poplar Grove Creek." State of Alaska, Dept. of Transportation and Public Facilities, Fairbanks, AK., Rpt. FHWA-AK-87-15.

- Weaver, C.R., 1963. "Influence of water velocity upon orientation and performance of adult migrating salmonids." US National Mar. Fish. Serv. Fish. Bulletin 63:97-121.
- Webb, P.W., 1971a. "The swimming energetics of trout. I) Thrust and power output at cruising speeds." J. Exp. Biol. 55:489-520.
- Webb, P.W., 1975. "Hydrodynamics and energetics of fish propulsion." *Bulletin of Fish. Res. Bd. of Can.*, Bull. 190, Ottawa, Canada.
- Webb, P.W., 1977. "Effects of size on Performance and Energetics of Fish," chapter in *Scale Effects in Animal Locomotion*, edited by T.J. Pedley, 1977, pp. 315-332. Academic Press, New York, N.Y.
- Welch, H.E., 1979. "Swimming performance of arctic char from the Saqvaquac River, N.W.T., Canada, Fish. Mar. Serv. Technical Report No. 854:IV. pp. 7.
- Ziemer, G.L., and Behlke, C.E., 1966. "Analysis of Salmon Capabilities in Steep Fish Ladders." Proceedings of 2nd Annual Water Resources Conference, 1966, pp. 328-339.

SUGGESTED ALASKA HYDROLOGY REFERENCES

- "A uniform technique for determining flood flow frequencies," 1967. Water Resources Council, Hydrology Committee, Bulletin 15, Washington, D.C.
- "Civil Works Investigations Project CW-151, Flood Volume Studies—West Coast," 1958. U.S. Army Engineer District, Sacramento, California. Research Note No. 1, Frequency of New England floods, July 1958.
- "Guidelines for determining flood flow frequency," 1982. Interagency Advisory Committee on Water Data, U.S. Department of the Interior, Geological Survey, Bulletin #17B, 28 pp + Appendices.
- Ashton, W.S., and Carlson, R.F., 1984. "Determination of seasonal, frequency, and durational aspects of streamflow with regard to fish passage through roadway drainage structures." State of Alaska, Department of Transportation and Public Facilities, Report No. AK-RD-85-06, 51 pp.
- Carlson, R.F., 1987. "Seasonal frequency and duration aspects of streamflow in Southeast and Coastal Alaska." State of Alaska, Department of Transportation and Public Facilities, Report No. FHWA-AK-RD-97-22, 40 pp.
- Jennings, M.E., and Benson, M.A., 1969. "Frequency curves for annual flood series with some zero events or incomplete data." *Water Resources Research*, Vol. 5, No. 1, 1969, pp 276-280.
- Kane, D.L., and Janowicz, J.R., 1989. "Flood frequency estimation for Alaska." State of Alaska, Department of Natural Resources, Division of Geological and Geophysical Surveys. Report of Investigations 88-17, 22 pp.
- Lamke, R.D., 1979. "Characteristics of Alaskan streams." U.S. Geological Survey, Anchorage, Alaska, Water Resource Investigations 78-129, 66 pp.
- Nguyen, V.T., In-na, N., and Bobec, B., 1989. "New plotting-position formula for Pearson Type-III distribution." *Journal of Hydraulic Engineering*, ASCE, pp 709-730.

APPENDIX A

Table A-1. Fish passage performance design categories for Alaskan fish species.

GROUP I—Adult and Juvenile Low-Performance Swimmers	Arctic grayling Longnose suckers Whitefish Burbot Sheefish Northern pike Dolly Varden/Arctic char Nine-spine stickleback Slimy Sculpin Upstream migrant salmon fry
GROUP II—Adult Moderate Performance Swimmers	Pink salmon Chum salmon Rainbow trout Cutthroat trout
GROUP III—Adult High Performance Swimmers	Chinook salmon Coho salmon Sockeye salmon Steelhead

Table A-2. Swimming performance of Alaskan fish species (L = total length of fish in meters; t = duration of swimming effort in seconds; velocity in meters per second). From Hunter et al. (1986); original field data source noted.

Species	Water Temp. (C)	Burst (m/s)	Sustained (m/s)	Source Data
Northern Pike	12-13		$1.17 * L^{0.55} * t^{-0.1}$	Jones et al. (1973)
Humpback Whitefish	7-20		$1.73 * L^{0.35} * t^{-0.1}$	Jones et al. (1973)
Broad Whitefish	12-13		$1.46 * L^{0.45} * t^{-0.1}$	Jones et al. (1973)
Burbot	7-20		$2.23 * L^{0.07} * t^{-0.26}$	Jones et al. (1973)
Pink Salmon	20		$4.08 * L^{0.55} * t^{-0.08}$	Brett (1982)
Coho Salmon	10-19	$13.30 * L^{0.52} * t^{-0.65}$		Weaver (1963) and Beamish (1978)
Coho Salmon	8-12		$3.02 * L^{0.52} * t^{-0.1}$	Glova and McInerney (1977), Davis et al. (1963), Flagg et al. (1983), and Howard (1975)
Coho Salmon	13-15		$5.67 * L^{0.7} * t^{-0.1}$	Glova and McInerney (1977), Davis et al. (1963), Flagg et al. (1983), and Howard (1975)

Table A-2 (continued). Swimming performance of Alaskan fish species (L = total length of fish in meters; t = duration of swimming effort in seconds; velocity in meters per second). From Hunter et al. (1986); original field data source noted.

Species	Water Temp. (C)	Burst (m/s)	Sustained (m/s)	Source Data
Coho Salmon	18-20		$5.87 * L^{0.7} * t^{-0.1}$	Glova and McInerney (1977), Davis et al. (1963), Beamish (1978), and Dahlberg et al. (1968)
Sockeye Salmon	2		$3.31 * L^{0.6294} * t^{-0.1}$	Brett and Glass (1973)
Sockeye Salmon	5		$3.63 * L^{0.6243} * t^{-0.1}$	Brett and Glass (1973)
Sockeye Salmon	10		$4.46 * L^{0.6294} * t^{-0.1}$	Brett and Glass (1973)
Sockeye Salmon	15-18		$5.21 * L^{0.6345} * t^{-0.09}$	Brett and Glass (1973) and Brett (1982)
Sockeye Salmon	18-20		$4.99 * L^{0.6293} * t^{-0.09}$	Brett and Glass (1973) and Brett (1982)
Sockeye Salmon	15		$4.42 * L^{0.5} * t^{-0.1}$	Brett (1965a)
Sockeye Salmon	10-15		$5.47 * L^{0.89} * t^{-0.07}$	Brett (1964, 1967, 1982)

Table A-2 (continued). Swimming performance of Alaskan fish species (L = total length of fish in meters; t = duration of swimming effort in seconds; velocity in meters per second). From Hunter et al. (1986); original field data source noted.

Species	Water Temp. (C)	Burst (m/s)	Sustained (m/s)	Source Data
Chinook Salmon	19	$11.49 * L^{0.32} * t^{-0.5}$		Weaver (1963)
Rainbow Trout	-	$7.16 * L^{0.77} * t^{-0.46}$		Bainbridge (1960)
Rainbow Trout	7-19	$12.8 * L^{1.07} * t^{-0.48}$		Bainbridge (1960), Weaver (1963), and Beamish (1978)
Rainbow Trout	7-19	$12.3 * L^{0.52} * t^{-0.51}$		Weaver (1963) and Beamish (1978)
Rainbow Trout	-	$15.88 * L^{0.81} * t^{-0.5}$		Webb (1977)
Rainbow Trout	10		$3.28 * L^{0.37} * t^{-0.1}$	Fry and Cox (1970)
Arctic Char	9-10		$3.74 * L^{0.606} * t^{-0.13}$	Welsh (1979) and Beamish (1980)
Arctic Char	9-10		$2.69 * L^{0.606} * t^{-0.08}$	Welsh (1979) and Beamish (1980)
Brook Trout	15		$1.99 * L^{0.43} * t^{-0.1}$	Beamish (1980)

Table A-2 (continued). Swimming performance of Alaskan fish species (L = total length of fish in meters; t = duration of swimming effort in seconds; velocity in meters per second). From Hunter et al. (1986); original field data source noted.

Species	Water Temp. (C)	Burst (m/s)	Sustained (m/s)	Source Data
Brook Trout	15		$2.71 * L^{0.52} * t^{-0.1}$	Beamish (1979, 1980) and Peterson (1974)
Sheefish	12-20		$1.29 * L^{0.175} * t^{-0.1}$	Jones et al. (1973)
Arctic Grayling	12-20		$1.67 * L^{0.193} * t^{-0.1}$	Jones et al. (1973)
Arctic Grayling	1-7.1	$7.2 * L^{.799} * t^{-.05}$		Behlke et al. (1988, 1989)
Arctic Grayling	1-7.1		$4.348 * L^{.797} * t^{-0.087}$	Behlke et al. (1988, 1989)
Arctic Grayling	1-7.1	$14.18 * L^{0.854} * t^{-0.1}$		Behlke et al. (1988, 1989), using Hunter et al. (1986) partial equation methodology

Table A-2 (continued). Swimming performance of Alaskan fish species (L = total length of fish in meters; t = duration of swimming effort in seconds; velocity in meters per second). From Hunter et al. (1986); original field data source noted.

Species	Water Temp. (C)	Burst (m/s)	Sustained (m/s)	Source Data
Arctic Grayling	1-7.1		$5.967 * L^{0.829} * t^{-0.11}$	Behlke et al. (1988, 1989), using Hunter et al. (1986) partial equation methodology

FUNDAMENTALS OF CULVERT DESIGN
FOR PASSAGE OF WEAK SWIMMING FISH

Report No. FHWA-AK-RD-90-10

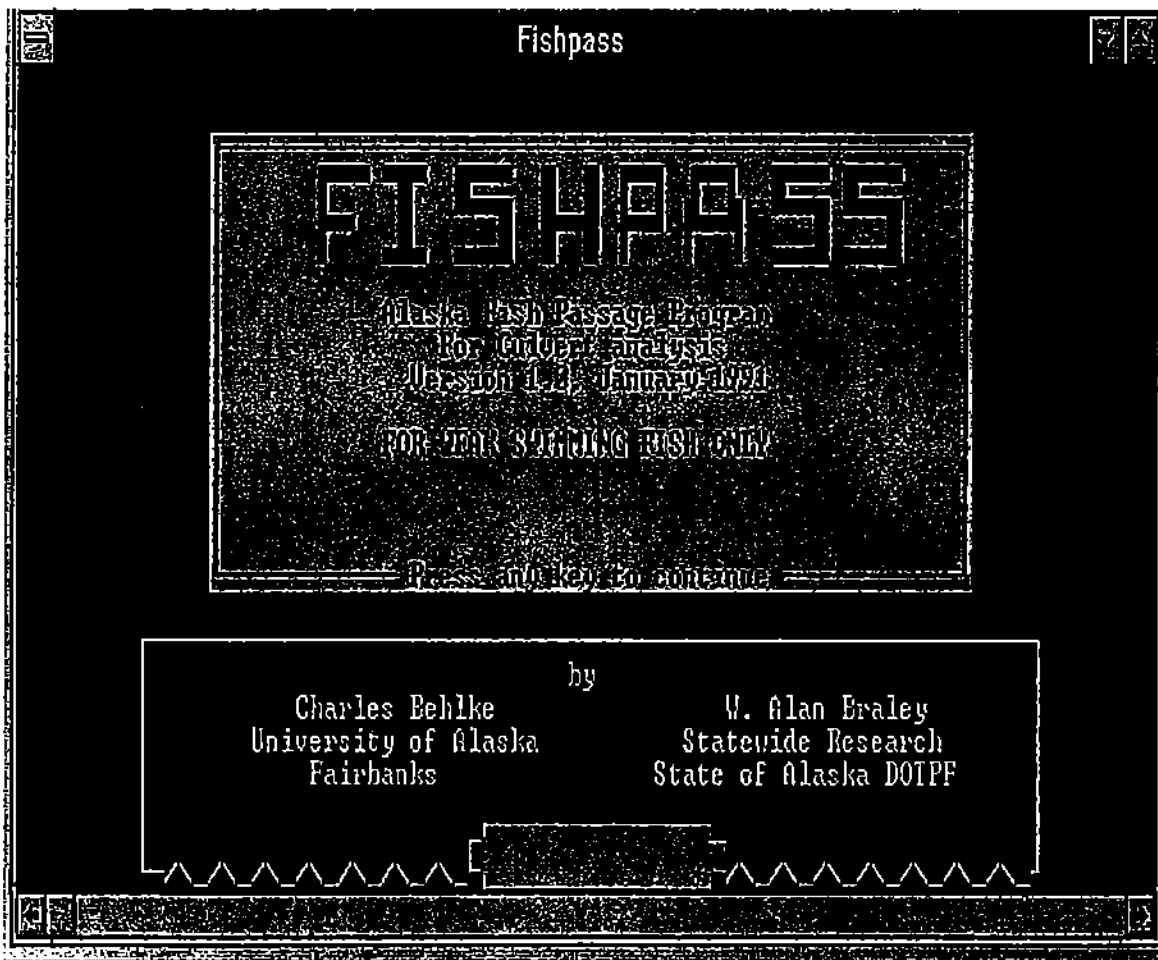

SOFTWARE DOCUMENTATION

November 1993

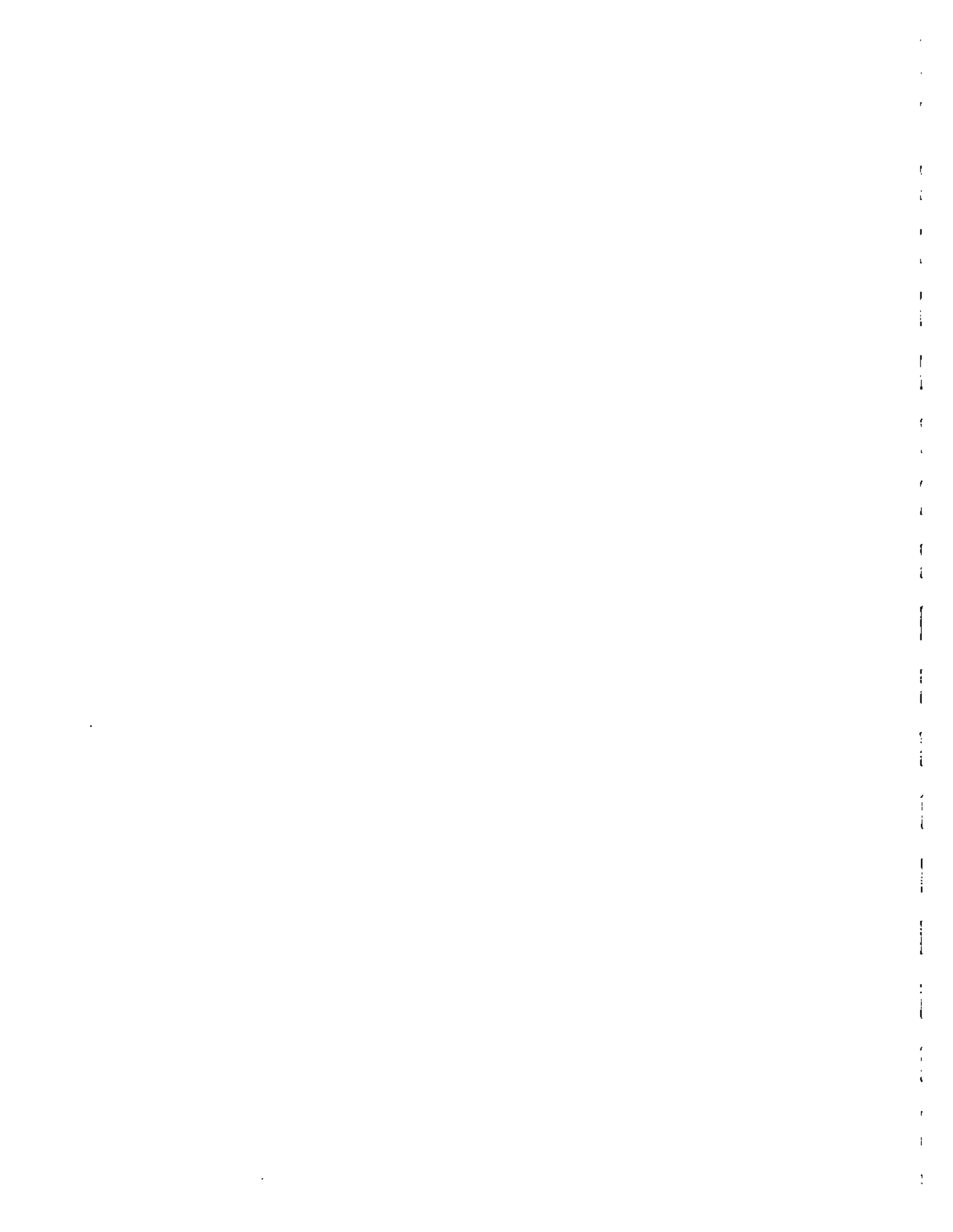

TABLE OF CONTENTS

Section	Page
Introduction.....	1
System Requirements.....	1
Cursor Control	1
Getting Started	2
Running "Culvert Analysis"	3
Menu Bar	3
Data Input Fields.....	5
Status Bar.....	7
Running "Weir Baffle Analysis".....	8
Menu Bar	8
Data Input Fields.....	9
Status Bar.....	9
A Note on Culvert Wall Corrugations	10
A Note on Depressed Invert Culverts	11
Additional Information	11

TABLE OF FIGURES

Figure	Page
1. Menu Screen for FISHPASS.EXE	2
2. "Culvert Analysis" Menu Bar	4
3. Data Input Fields for "Culvert Analysis".....	5
4. Calculated Fish Parameters Output Fields for "Culvert Analysis".....	7
5. Menu Bar for "Weir Baffle Analysis"	8
6. Calculated Parameters Output Fields for "Weir Baffle Analysis"	10

FUNDAMENTALS OF CULVERT DESIGN
FOR PASSAGE OF WEAK SWIMMING FISH
Report No. FHWA-AK-RD-90-10

SOFTWARE DOCUMENTATION



INTRODUCTION

WELCOME to FISHPASS.EXE. FISHPASS provides the analytical capabilities to identify a culvert or parallel culverts that will pass weak swimming fish safely. The design procedure utilizes hydraulic formulas for profile drag, non-Archimedean buoyant forces, and virtual mass force to quantify the hydraulic conditions within a culvert that weak swimming fish can sustain without exhaustion.

Before using FISHPASS.EXE, read and be thoroughly familiar with the "Fundamentals of Culvert Design for Passage of Weak Swimming Fish", (Behlke et al. 1991. Alaska DOTPF Statewide Research Report Number FHWA-AK-RD-90-10). The required software data inputs and design results only will make sense if you are familiar with the underlying theory, foundation, and assumptions it explains.



SYSTEM REQUIREMENTS

Minimum: DOS 3.31 or higher with an 80286, 8088 or 8086 processor with 640 KB of RAM and a monochrome monitor is required.

A math co-processor will speed the computations up, but be aware that the program will run very slowly on an 80286, 8088, or 8086 processor.

Preferred: An 80386 processor, with a math co-processor, or an 80486-DX2 processor with a color monitor is recommended. The program is mouse-supported but can be run directly from the keyboard.

Disk Space: The FISHPASS.EXE file occupies 181,728 KB of disk space. 



CURSOR CONTROL

Select a Menu field or a Data Input field by using the <ENTER> key or by clicking on the field with a mouse.

A mouse, <SHIFT-TAB> or the left and right cursor control keys can be used to move between fields. The <BACKSPACE>, <INSERT>, and <DELETE> keys can be used to edit a field entry.

The <ESC> key will return the previous screen. Please note that if the <ESC> key is held down too long the initial FISHPASS.EXE menu screen will be returned, and the menu defaults and data input variables will have to be re-entered.



GETTING STARTED

FISHPASS.EXE can be run directly from a floppy drive or copied to the hardrive.

FISHPASS.EXE will also run under Microsoft Windows as a nonwindows application program.

To start FISHPASS.EXE from the DOS prompt, type "Fishpass."

Example: A:\fishpass
or
C:\<sub-directory>\fishpass

Press any key to bypass the title screen and access the menu screen (Figure 1).

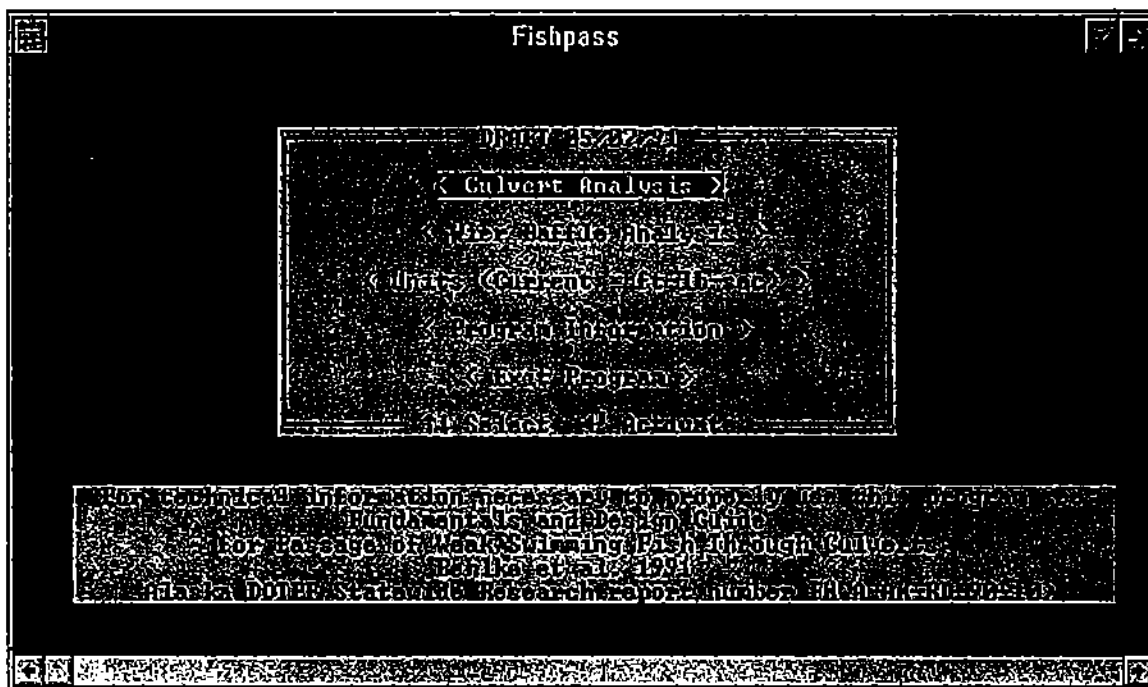

Figure 1. Menu Screen for FISHPASS.EXE.

You can select one of the following options from the menu screen:

MENU SCREEN OPTIONS	
Culvert Analysis:	<p>This program evaluates relatively flat sloping, <u>circular</u> culverts. The culvert may or may not have a depressed invert. Use it for original design work or retrofitting an existing culvert.</p> <p>Restriction: Culvert slopes must range between 0.1 to 10 percent.</p> <p><i>At this time, the program will not evaluate elliptical culverts. A BASIC program has been developed that allows an approximate evaluation of elliptical culverts for water depths less than 3/10 of the culvert diameter. Please contact either Charles E. Behlke or Robert F. McLean (see listing under Additional Information) for further information.</i></p>
Weir Baffle Analysis:	<p>The Canadian weir baffle design technique is used to evaluate fish passage when culvert slope or water flow is excessive and impedes fish passage.</p> <p>Restriction: Culvert slopes must range between 0.1 to 10 percent.</p>
Units:	<p>English foot-pound-second units are the system default. The SI metric system of units can be selected as an option.</p>
Information:	<p>Contains a brief description of the FISHPASS.EXE program.</p>
Exit:	<p>Returns you to the DOS prompt.</p>



RUNNING "CULVERT ANALYSIS"

Prior to using "Culvert Analysis," select a culvert that meets the design flood requirements (generally the 50-year flood).

After the trial design flood culvert is selected, use the "Culvert Analysis" program to evaluate its suitability for fish passage at the fish passage design flood.

Menu Bar: The Menu Bar is located at the top of the screen. With it, select the help menu or define the printer options, culvert inlet type, calculation mode, and corrugation height (Figure 2).



Figure 2. "Culvert Analysis" Menu Bar.

The Menu Bar can be selected with the mouse or by typing <ALT> followed by the highlighted letter for each field.

MENU BAR OPTIONS	
Help:	General information or specific instructions for selected fields or calculated parameters can be obtained. Information on selected input data fields also can be obtained at any time by placing the cursor within that field and typing <F1>. <i>Example: To activate the help menu for the "Minimum Flow Depth" output field, type <ALT> <Help> <Calculated Parameters>, then use the cursor control keys or mouse to highlight "Min. Flow Depth." Press enter or click the mouse to obtain the help message in a box at the bottom of the screen.</i>
Print:	Defines the printer options. Select to print either the current screen, the backwater curve, or both. Direct your printer output to either the LPT1 or LPT2 port.
Inlet:	Select a projecting, flush headwall, or bevelled, flush headwall. The inlet type effects the drop in water surface elevation as the water enters the culvert and effects the fish's ability to exit the culvert at the inlet. The inlet type must be specified each time the program is run. If the stream is incised and the culvert diameter is approximately the same as the stream width, the "flush headwall, beveled" inlet type should be used.
CalcMode:	Defines the calculation mode. Select automatic, manual, or recalculation mode.
Corrugation:	Sets the culvert corrugation height. The program's default value is "Greater than 1.25 inches." This value must be changed if a 3-inch-by-1-inch or smaller corrugation is proposed. The corrugation height effects flow velocities near the culvert boundary (where weak fish swim), effecting how fast the fish must swim in the barrel of the culvert. Two-inch deep corrugations are highly recommended for fish passage culverts. This program does not apply to smooth-walled culverts.

Data Input Fields: After the appropriate values are entered within the Menu Bar for Inlet Type, CalcMode, and Corrugations, the cursor will drop down to the data input fields (Figure 3).

The screenshot shows a software window titled 'Fishpass' with a menu bar (File, Edit, Options, Statistics, Database, Help) and a toolbar. The main window title is 'Weak Swimming Fish Passage'. Below the title bar is a table with input fields for various parameters:

Length		Slope (%)	Manning n		Q (cfs)	Culvert Dian. (ft)	Depth	
Fish (mm)	Culvert (ft)		Wall	Bed			Bed (ft)	Outlet (ft)
240	100	5	0.035	0.035	30	2	0	1.5

Figure 3. Data Input Fields for "Culvert Analysis."

The following input variables must be entered for each trial culvert design:

"CULVERT ANALYSIS" DATA INPUT VARIABLES

Fish Length: The fork length of the design fish must be entered in millimeters.
Note: The length always must be entered in millimeters even if the system default is set to English foot-pound-seconds. The length must be obtained from the resource agency responsible for managing the fish resources. Generally, the design length reflects the minimum size class for upstream migrant spawning fish.

Length: The length of the culvert must be entered in feet or meters.

Culvert Slope: Enter the slope of the culvert bottom as a percentage (i.e., 1% not 0.01).

Culvert Wall Manning n Value: Enter the Manning *n* for the culvert wall. Values from 0.02 to 0.05 can be entered. We suggest using 0.035 for two-inch deep corrugations.

Culvert Bed Manning n Value: Enter the Manning *n* for stream bed material that will be present within the culvert. Values from 0.02 to 0.05 can be entered.
A non-zero value must be entered here and in the input field for the depth of bed material if you are analyzing a depressed invert culvert.

(Continued)

"CULVERT ANALYSIS" DATA INPUT VARIABLES
(Continued)

- Q (cfs):** Enter the fish passage design flow in cubic feet or meters per second.
- Fish passage design flow is not the same as the culvert design or flood flow. The flood flow is the maximum discharge anticipated during the design life of the culvert. The fish passage design flow is the maximum discharge for which fish passage must be assured.*
- In Alaska, this has been defined by the Alaska Department of Fish and Game as the mean annual, two-day duration flood ($Q_{2.33} - 2 \text{ day}$) for the specific time of the year that fish migrate upstream. For Arctic grayling, the design fish passage flow is the SPRING mean annual, two-day duration flood.*
- Diameter:** Input the diameter of the culvert barrel in feet or meters.
- Bed Depth:** Enter the depth of the bed material above the culvert invert in feet or meters.
- If the culvert is "bare" and will not contain bedload material, a red reminder notice will pop up. Ignore it by pressing <ENTER>.*
- Outlet Depth:** Enter the tailwater depth in feet or meters.
- The tailwater depth is the water surface elevation above the culvert invert and is used during the calculation of the backwater curve. Note that the culvert invert is the bottom of the culvert or the top of the bed material if the culvert is depressed and partially filled by such material. The value must be greater than the hydraulic critical depth for the design culvert diameter and discharge and less than the culvert diameter minus the bed depth.*

If the program is in the automatic calculation mode when the final input data is entered, the program will calculate the "Calculated Fish Parameters" and generate a backwater curve for the specified flow conditions. The screen will automatically shift to the backwater screen where the backwater curve is printed.

Please note that even for an otherwise suitable fish passage culvert some of the flow depths may be less than the "Safe fish passage flow depth." This is because the program calculates the "Safe fish passage depth" based on the minimum depth of flow required for the stated culvert diameter and discharge to maintain velocities at or below the maximum allowable fish passage velocity. This velocity threshold is based on the design fish's red muscle swimming power (sustained speed). If the program detects depths less than this

depth at or near the culvert outlet, it runs until it finds that the swimming fish has run out of white muscle power or energy (burst speed), then it stops (as does the fish!).

The <ESC> key returns you back to the previous screen where the calculated hydraulic and fish swimming performance parameters are presented (Figure 4).

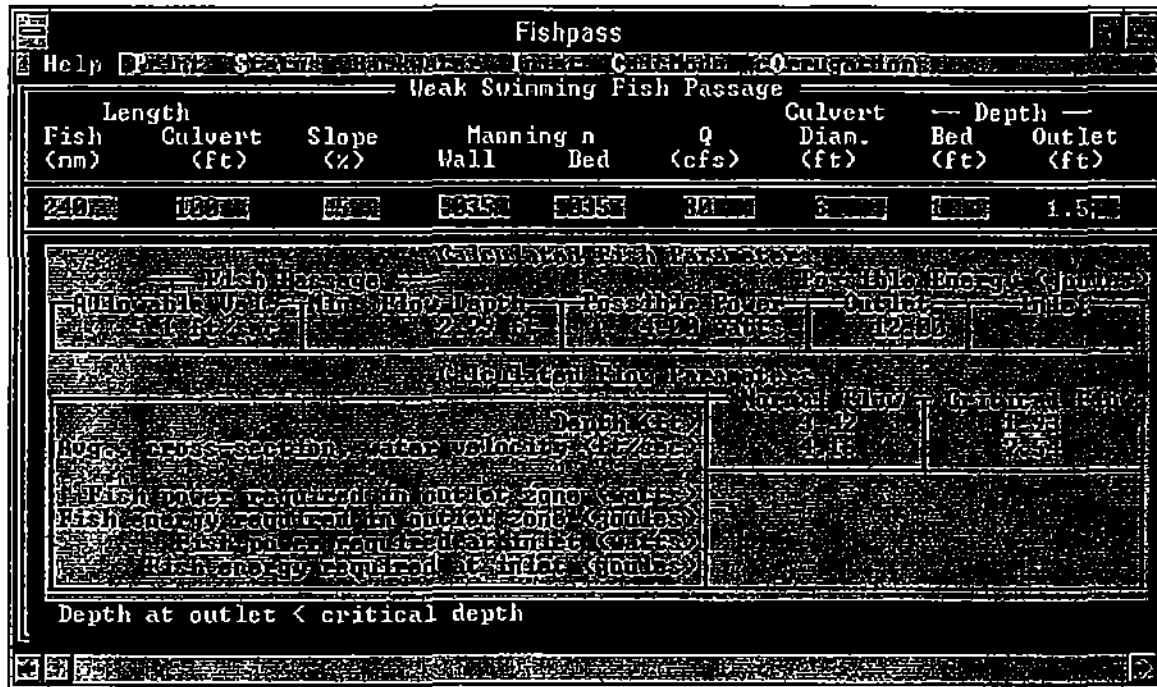

Figure 4. Calculated Fish Parameters Output Fields for "Culvert Analysis."

Status Bar: The red Status Bar is located on the next-to-last bar on this screen. A short message is included in this bar indicating that the culvert is acceptable for fish passage, or indicating the specific problem with the proposed culvert.

If the initial culvert is unsatisfactory, review the proposed installation and input a different culvert slope, diameter, entrance condition, depression, outlet pool elevation, or culvert bottom fill Manning n value. Change these parameters one at a time to obtain a culvert design that will pass fish successfully. Pay particular attention to the relative economics of one change versus another.

If the initial culvert is suitable for fish passage, in the interests of culvert economics try a smaller diameter, greater slope, less expensive culvert inlet, less outlet pool depth, etc. to determine the most cost-effective design that still provides acceptable fish passage. If unreasonable outlet control designs are required, consider trying a weir baffle design.

Some culvert designs allow fish to enter and pass through the culvert barrel but do not allow fish to exit the culvert inlet. This situation will be indicated on the red Status Bar and often can be solved by simply changing the culvert inlet condition (e.g., using a flush or bevelled headwall instead of a projecting inlet). If these adjustments do not solve the problem, a larger diameter culvert or more outlet pool depth may be necessary. When you have selected the proper geometry for fish passage, re-check the culvert dimensions for design flood flow.



RUNNING "WEIR BAFFLE ANALYSIS"

For culverts so steeply sloped that no suitable culvert can be found using "Culvert Analysis," either relocate the culvert location to a stream segment with lower slopes or use the "Weir Baffle Analysis."

The weir baffle spacing for this program must be 0.6 times the culvert diameter (0.6 D). All weir baffled culverts designed using this program must have this weir spacing or the program results are meaningless. The two weir heights used are 0.1 D and 0.15 D.

NOTE: Please refer to Section IV.C.4.d of the background report for a better understanding of the weir baffle height and spacing requirements and for other baffle geometries not supported by this software.

Menu Bar: The Menu Bar is located at the top of the screen. With it, you can access the help menu, define the printer options, or obtain a status report (Figure 5).



Figure 5. Menu Bar for "Weir Baffle Analysis."

The Menu Bar can be selected with the mouse or by typing <ALT> followed by the highlighted letter for each field. The following options can be selected:

MENU BAR OPTIONS	
Help:	You can obtain general information or specific instructions for selected fields or calculated parameters. Information on selected input data fields also can be obtained at any time by placing the cursor within that field and typing <F1>.
Print:	Defines the printer options. You can direct your printer output to either the LPT1 or LPT2 port.
Status:	Provides a status summary on the fish passage characteristics of the trial culvert design. This option is activated only after the data input parameters have been entered.

Data Input Fields: The following input variables must be entered for each trial weir baffled culvert design:

"WEIR BAFFLE ANALYSIS" DATA INPUT VARIABLES

- Fish Length:** The fork length of the design fish must be entered in millimeters.
- NOTE: The length always must be entered in millimeters even if the system default is set to English foot-pound-seconds. The length must be obtained from the resource agency responsible for managing the fish resources. Generally, the design length reflects the minimum size class for upstream migrant spawning fish.*
- Culvert Slope:** Enter the slope of the culvert bottom as a percentage (i.e., 1% not 0.01).
- Culvert Wall Manning *n*:** Enter the Manning *n* for the culvert wall. Values from 0.02 to 0.05 are allowed.
- We suggest using 0.035 for two-inch deep corrugations.*
- Q Fish (cfs):** Enter the design fish passage flow in cubic feet or meters per second.
- The fish passage design flow is the maximum discharge for which fish passage must be assured. In Alaska, the fish passage design flow has been defined by the Alaska Department of Fish and Game as the mean annual, two-day duration flood ($Q_{2.33 - 2 \text{ day}}$) for the specific time of year that fish migrate upstream. For Arctic grayling, the design fish passage flow is the SPRING mean annual, two-day duration flood.*
- Q Flood (cfs):** Enter the design flood flow in cubic feet or meters per second.
- Unlike "Culvert Analysis," flood flow must be entered since the FHWA design software does not have the capabilities to analyze flows through this type of weir baffled culvert.*
- Diameter:** Enter the diameter of the culvert barrel in feet or meters.

Status Bar: The red Status Bar is located on the next-to-last bar on this screen. A short message states that the culvert is acceptable for fish passage, or states the specific problem with the proposed culvert (Figure 6).

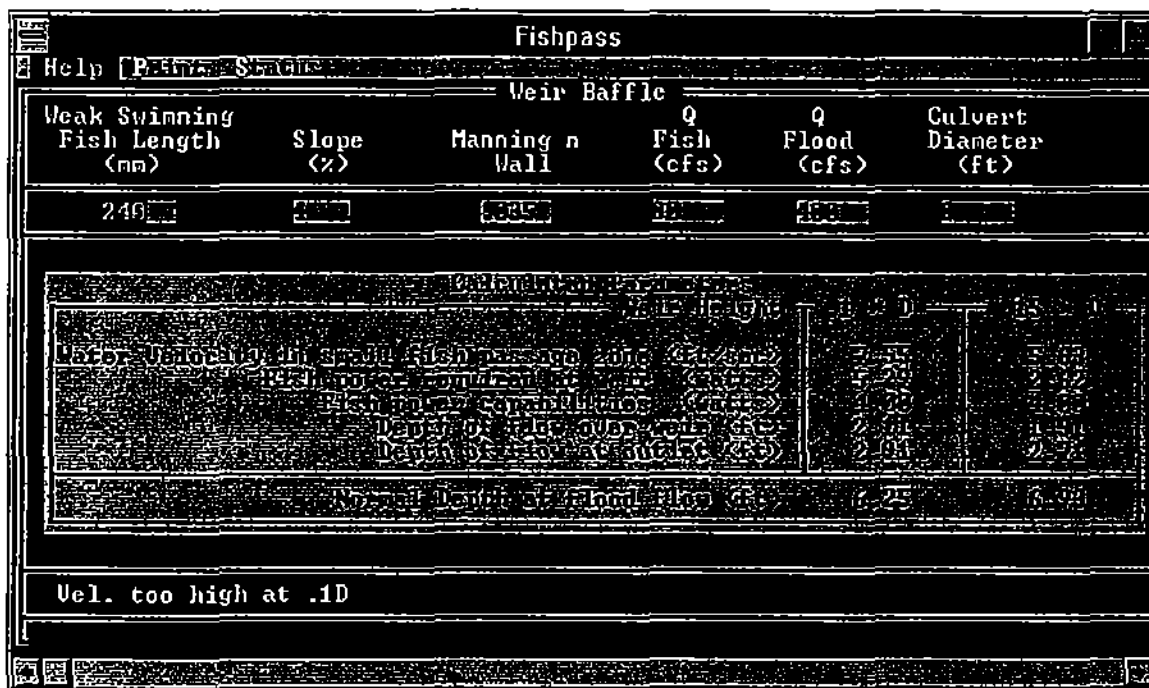

Figure 6. Calculated Parameters Output Fields for "Weir Baffle Analysis."



A NOTE ON CULVERT WALL CORRUGATIONS

Effective boundary roughness is virtually a necessity for effective fish passage. We encourage the use of culvert materials that result in relatively high Manning n factors. In particular, we recommend the use of corrugated structural steel plate pipes (SSP) with corrugations 6-inch-by-2-inch (15.2-cm-by-5.1-cm) or 9-inch-by-2.5-inch (22.9-cm-by-6.3-cm) for all fish passage structures.

Based on our field assessments, boundary zone water velocities in these rougher culverts typically range between 10-to-50 percent of the average cross-sectional water velocity (Q/A). In contrast, boundary zone water velocities for shallower corrugations (less than 1.25 inches) typically are 60 to 80 percent of the average cross-sectional water velocity. We particularly discourage the use of spiral (helical) and smooth-wall culverts due to their relatively small Manning n values.

This recommendation does not preclude the use of smaller corrugations; however, the maximum fish passage design discharge must be reduced or the culvert diameter increased from what these parameters would be for two-inch-diameter corrugations.



A NOTE ON DEPRESSED INVERT CULVERTS

The design program allows for, but does not require, installation of a depressed invert culvert. What the program does require is a tailwater depth elevation generally equal to or greater than the hydraulic critical depth (outlet control). Ideally, this should be achieved through design and construction of a downstream energy dissipation pool using generally accepted methods such as those outlined in the FHWA publication "Hydraulic Design of Energy Dissipators for Culverts and Channels" (1983). Dissipation of outlet energy is essential to prevent downstream erosion of the streambed and subsequent loss of the required tailwater elevations. Under extreme circumstances, excessive velocities will lead to a "perched" culvert.

In some cases, the culvert invert can be depressed to increase barrel roughness and enhance the tailwater rating curve. The deposition of coarse bedload material within the culvert bed can enhance fish passage characteristics. In other cases, a designer may opt to depress the culvert invert as a safety margin when there is uncertainty whether necessary tailwater depths will be provided or maintained over the life of the structure.



ADDITIONAL INFORMATION

If you have additional questions or if the program does not work properly, please call or write us. Also, please send your suggestions for improving FISHPASS.EXE to us at the following addresses:

Charles E. Behlke
Box 82230
Fairbanks, AK 99708
Tel. No. (907) 457-5236
FAX No. (907) 457-1375
E-Mail: corjbehlke@compuserve.com

or

Robert F. "Mac" McLean
AK Dept. of Fish and Game
1300 College Road
Fairbanks, AK 99701
Tel. No. (907) 459-72811
FAX No. (907) 456-3091
E-Mail: mmclean@fishgame.state.ak.us