

LIBERTY DEVELOPMENT PROJECT

DEVELOPMENT AND PRODUCTION PLAN

Revision 2

July 31, 2000

SUBMITTED TO:
U.S. MINERALS MANAGEMENT SERVICE
ALASKA OCS REGION
949 E. 36TH AVENUE, ROOM 308
ANCHORAGE, ALASKA 99508-4392

SUBMITTED BY:
BP EXPLORATION (ALASKA) INC.
P.O. BOX 196612
ANCHORAGE, ALASKA 99519-6612

TABLE OF CONTENTS

TABLE OF CONTENTS

| | |
|--|-----------|
| 1. INTRODUCTION..... | 1 |
| 1.1 LIBERTY PROJECT HISTORY | 1 |
| 1.2 PROJECT OVERVIEW | 2 |
| 1.3 PERMITS AND APPROVALS..... | 2 |
| 2. SCHEDULE | 10 |
| 2.1 CONSTRUCTION..... | 10 |
| 2.1.1 Ice Road Construction..... | 10 |
| 2.1.2 Mine Site Development | 10 |
| 2.1.3 Island Construction | 11 |
| 2.1.4 Pipeline Construction..... | 11 |
| 2.1.5 Fabrication | 12 |
| 2.1.6 Assembly..... | 12 |
| 2.1.7 Facilities Installation..... | 12 |
| 2.2 DRILLING..... | 12 |
| 2.3 OPERATIONS..... | 13 |
| 3. GEOLOGY AND RESERVOIR DEVELOPMENT | 19 |
| 3.1 GENERAL RESERVOIR DESCRIPTION..... | 19 |
| 3.2 SHALLOW HAZARDS | 20 |
| 3.3 HYDROGEN SULFIDE..... | 21 |
| 4. PROJECT ACCESS | 27 |
| 4.1 ACCESS NEEDS AND OPTIONS | 27 |
| 4.1.1 Air Access | 27 |
| 4.1.2 Ice Roads..... | 27 |
| 4.1.3 Marine Access..... | 29 |
| 4.2 ACCESS BY PROJECT PHASE | 29 |
| 4.2.1 Construction Access..... | 29 |
| 4.2.2 Drilling and Production Operations Access..... | 30 |
| 5. GRAVEL ISLAND | 34 |
| 5.1 ISLAND STRUCTURE..... | 34 |
| 5.2 ISLAND SURFACE LAYOUT | 36 |

| | |
|---|-----------|
| 6. FACILITIES | 45 |
| 6.1 DESIGN BASIS..... | 45 |
| 6.2 OIL AND GAS PROCESS SYSTEM..... | 45 |
| 6.2.1 Design Philosophy | 45 |
| 6.2.2 Process Summary..... | 47 |
| 6.3 SEAWATER INTAKE AND WATERFLOOD FACILITIES | 49 |
| 6.4 PROCESS SAFETY SYSTEMS..... | 50 |
| 6.5 INCREASED PRODUCTION OPTION..... | 52 |
| 7. DRILLING | 55 |
| 7.1 INTRODUCTION | 55 |
| 7.2 LIBERTY ISLAND AND DRILLING FOOTPRINT..... | 55 |
| 7.2.1 Island Layout | 55 |
| 7.2.2 Well Spacing..... | 56 |
| 7.2.3 Drilling Footprint..... | 56 |
| 7.3 DRILLING UNIT | 57 |
| 7.4 WELL DESIGN..... | 57 |
| 7.4.1 Casing Design..... | 57 |
| 7.4.2 Directional Drilling and Surveying..... | 58 |
| 7.4.3 Drilling Fluids & Cementing..... | 58 |
| 7.4.4 Data Acquisition | 59 |
| 7.5 COMPLETION DESIGN | 59 |
| 7.6 WASTE MANAGEMENT | 59 |
| 7.6.1 Disposal Well..... | 60 |
| 7.6.2 Cuttings Processing and Injection Equipment | 60 |
| 7.7 LOGISTICS | 60 |
| 7.7.1 General..... | 60 |
| 7.8 WELL CONTROL..... | 61 |
| 8. PIPELINE SYSTEM | 67 |
| 8.1 PIPELINE ROUTE..... | 67 |
| 8.2 DESIGN..... | 67 |
| 8.3 CONSTRUCTION..... | 69 |
| 8.4 SAFETY AND LEAK PREVENTION MEASURES..... | 74 |
| 8.5 MONITORING AND SURVEILLANCE..... | 75 |
| 9. INFRASTRUCTURE AND SUPPORT FACILITIES..... | 87 |
| 9.1 UTILITIES AND INFRASTRUCTURE..... | 87 |
| 9.1.1 Seawater Inlet Facilities..... | 87 |
| 9.1.2 Infrastructure..... | 87 |
| 9.1.3 Electrical Power | 88 |

9.2 SUPPORT FACILITIES.....89

 9.2.1 Ice Roads.....90

 9.2.2 Gravel Sources91

 9.2.3 Construction Camp/Support92

 9.2.4 Water Sources93

10. DESIGN REVIEW AND ASSURANCE PROCESSES.....96

 10.1 PIPELINE DESIGN REVIEW96

 10.2 ISLAND DESIGN REVIEW.....97

 10.3 OTHER MMS REVIEWS98

11. EMPLOYMENT100

12. ENVIRONMENTAL SAFEGUARDS102

 12.1 HABITAT AND WILDLIFE PROTECTION.....102

 12.2 POLLUTION PREVENTION103

 12.3 DISCHARGES AND EMISSIONS.....104

 12.4 WASTE MANAGEMENT104

 12.4.1 Strategies by Project Phase105

 12.4.2 Management Options by Waste Stream.....106

13. OPERATIONS AND MAINTENANCE.....111

 13.1 SAFETY EQUIPMENT111

 13.1.1 Firefighting Philosophy and Equipment111

 13.1.2 Fire & Gas Detection, Alarm Action and H&V Philosophy111

 13.2 CRITERIA112

14. TRAINING115

15. PROJECT TERMINATION116

16. SINGLE SEASON SCHEDULE OPTION AND CONSTRUCTION CONTINGENCIES117

APPENDIX A - Waste Disposal Well

APPENDIX B - Environmental Report Supplement

LIST OF TABLES

| | | |
|------|---|-----|
| 1-1 | Permits and Approvals Required for Liberty Development | 4 |
| 1-2 | Development and Production Plan Cross Reference to 30 CFR 250.204..... | 6 |
| 2-1 | Proposed Drilling Sequence..... | 14 |
| 3-1 | Estimated Well Depths | 22 |
| 4-1 | Liberty Project Transportation Needs | 28 |
| 4-2 | Estimated Liberty Transportation Requirements | 32 |
| 5-1 | Design Summary for Liberty Drilling / Production Island | 35 |
| 6-1 | Liberty Design Capacities and Specifications | 46 |
| 7-1 | Liberty Development Drilling Program..... | 55 |
| 8-1 | Pipeline Trench Excavation and Backfill Volumes | 76 |
| 10-1 | MMS Review and Approval Authorities | 99 |
| 16-1 | Estimated Liberty Transportation Requirements - Single Season Option..... | 118 |

LIST OF FIGURES

(note: figures are located at end of each section)

| | |
|-----|---|
| 1-1 | Liberty Development Project Vicinity Map |
| 1-2 | Proposed Liberty Development Project |
| 2-1 | Liberty Development Project Schedule |
| 2-2 | Liberty Development Project Overall Construction Schedule |
| 2-3 | Liberty Development Project Ice Road System (Construction and Operations) |
| 2-4 | Liberty Development Project Production Profile |
| 3-1 | Liberty Development Project Liberty Field |
| 3-2 | Liberty Development Project Depth Structure in LCU Top Reservoir |
| 3-3 | Liberty Development Project Production Plan Structure Cross Section A-A' |
| 3-4 | Liberty Development Project Structure Cross Section B-B' |
| 4-1 | Liberty Development Seasonal Access Limitations |
| 5-1 | Liberty Development Project Island Layout |
| 5-2 | Liberty Development Project Island Cross Section A-A' |
| 5-3 | Liberty Development Project Island Cross Section B-B' |

5-4 Liberty Development Project Island Slope Protection Cross Section and Detail
5-5 Liberty Development Project Island Slope Protection Concrete Mat Layout
5-6 Liberty Development Project Island Slope Protection Concrete Block
5-7 Liberty Development Project Island Slope Protection Concrete Mat Linkage Detail
6-1 Liberty Development Project Simplified Process Flow Diagram
6-2 Liberty Development Project Seawater Intake Detail
7-1 Liberty Development Project 1/2" Monobore Producer
7-2 Liberty Development Project 5 1/2" Pre-Produced Gas Injector
7-3 Liberty Development Project 5 1/2" Gas Injector
7-4 Liberty Development Project 5 1/2" Water Injector
8-1 Liberty Development Project Island Pipeline Approach Cross Section
8-2 Liberty Development Project Dredged Material Sites Zones 1 & 2
8-3 Liberty Development Project Trench Section Shallow Area 0' - 8'
8-4 Liberty Development Project Trench Section Intermediate/Deep Area 8' - 21'
8-5 Liberty Development Project Landfall Valve Pad Layout
8-6 Liberty Development Project Landfall Valve Pad Cross-Section North-South
8-7 Liberty Development Project Typical Onshore Pipeline Transition Backfilled Trench Section
8-8 Liberty Development Project Badami Tie-In Pad Plan View
8-9 Liberty Development Project Badami Tie-In Pad Cross-Sections
8-10 Liberty Development Project Detail of Gravel Bag Placement over Pipeline
9-1 Liberty Development Project Island Layout with Construction Camp (Optional Configuration)
9-2 Liberty Development Project Island Cross Section A-A' with Construction Camp
12-1 Liberty Development Project Island Grading and Drainage Plan
16-1 Liberty Development Schedule - Single Season Option
Exhibit A Proposed Liberty Development Plan - Exhibit A (in rear pocket)

Note to Reader

On February 17, 1998, BP Exploration (Alaska) Inc. submitted a Development and Production Plan to the U.S. Minerals Management Service (MMS) for review and approval of the proposed Liberty Development. Since submittal of the DPP, BPXA has continued final design and project optimization studies. As a result of this ongoing work, BPXA identified several modifications to the Liberty project, as described in the original DPP. Accordingly, BPXA has issued Revision 2 of the DPP to describe these project modifications; the February 17, 1998 version of the DPP has been entirely replaced with Revision 2. Note that an interim document, Revision 1, was issued on November 9, 1998.

Scope changes from the DPP submitted on February 17, 1998 include:

- a two year construction schedule*
- clarification on use of a construction camp and more likelihood of use of a camp barge*
- refined traffic forecasts*
- more likelihood of use of hydraulic (suction pump) dredge*
- additional ice road and ice pad segments*
- an automated valve at the shore crossing, with an option to use a vertical loop*
- deletion of the products pipeline*
- incorporation of a supplemental leak detection system*
- identification of disposal areas for excess material excavated from the pipeline trench*
- two season gravel mining*
- burying gravel-filled bags over the pipeline to assure vertical pipeline stability*
- increased requirements for temporary diesel storage during construction*
- minor changes in the island design, including slope protection dimensions, island footprint, dock dimensions, and the island/pipeline transition*
- identification of an increased production option*

In addition, a Supplement to the February 17, 1998 Environmental Report addresses these scope changes. This Supplement is not a stand-alone document, and must be used with the February 17, 1998 Environmental Report. It has been bound into this Revision of the DPP as Appendix B for ease of reference. The Supplement briefly describes impacts of the project modifications, and incorporates additional information provided to MMS by BPXA since February 1998. Note that Section 3 of the February 17, 1998 Environmental Report has been superseded and replaced by Revision 2 of the DPP.

1. INTRODUCTION

BP Exploration (Alaska) Inc. (BPXA) proposes to develop the Liberty oil field, located on the Outer Continental Shelf (OCS), in Foggy Island Bay (Exhibit A). Liberty is located on a single lease, OCS-Y1650, acquired under OCS Lease Sale 144. BPXA holds a one hundred percent interest in this lease, and would be owner and operator of the Liberty Field. In accordance with the requirements of 30 CFR Part 250.204, this Development and Production Plan (DPP) has been prepared to describe the full scope of activity associated with Liberty construction, drilling, and production operations. This DPP is being submitted to the U.S. Minerals Management Service (MMS) for review and approval of the proposed Liberty Development.

1.1 LIBERTY PROJECT HISTORY

The Liberty Prospect was first discovered by Shell Oil Company who, from 1982 to 1987, drilled four wells to evaluate the potential of the target Kekiktuk Formation. Three of the wells were drilled from Tern Island, which Shell constructed in 1981-1982. The fourth well was drilled from Goose Island, located southeast of Tern Island (Figure 1-1).

In September 1996, BPXA acquired Tract OCS-Y1650 in MMS OCS Lease Sale 144, and initiated permitting activity for the Liberty #1 Exploration Well. The tophole location for this well was located on a gravel/ice structure on top of the abandoned Tern Island on Tract OCS-Y1585 (Lease Sale 124), with the bottomhole location in Tract OCS-Y1650.

Drilling of the Liberty #1 well began in February 1997, followed by well testing in March 1997. The drilling operation was demobilized in April 1997. Based on interpretation of geologic interpretation, seismic data, and well tests, on May 1, 1997 BPXA confirmed the discovery of an estimated 120 million barrels of recoverable reserves from the Liberty prospect.

To accelerate the schedule for project development, BPXA initiated conceptual engineering late in 1996. This effort was based on assumed exploratory well results, and focused on identification and screening of project development alternatives. Factors considered in the conceptual engineering process were reservoir development, costs, technical and logistical feasibility, and environmental protection. Project goals were to identify the best development option that balanced resource recovery, short-term and long-term costs, and environmental performance.

By May 1997 a proposed Liberty Development test case had been developed, which included an offshore gravel island with full processing facilities, a subsea pipeline system, and associated infrastructure. In May 1997, BPXA formed the Liberty Alliance to proceed with preliminary engineering. The major goals of preliminary engineering were to define the project

sufficiently for internal project approvals and to provide the basis for permit applications to federal, state, and local agencies. The Alliance is a design/build organization, and includes:

- BPXA
- VECO Engineering/VECO Construction (Alaska-based contractor)
- Alaska Petroleum Contractors (Alaska-based contractor)
- Houston Contracting Company (Alaska-based contractor)
- Alaska Interstate Construction (Alaska-based contractor)
- Mustang Engineering
- National Tank Company
- INTEC Engineering

During the period from December 1998 to February 1999, BPXA decided to delay the Liberty project schedule for two years. During 1999 and part of 2000, engineering effort has been put on hold. The project is currently in the process of initiating final design.

1.2 PROJECT OVERVIEW

The BPXA Liberty development will be a self-contained offshore drilling/production facility located on a conventional gravel island with pipelines to shore (Figure 1-2). This island will be built in Foggy Island Bay in approximately 21 feet of water, about 1.5 miles west of the abandoned Tern Island.

Infrastructure and facilities necessary to drill wells and process and export 65,000 barrels of oil per day to shore will be installed on the island. There will be 14 producing wells, six water injection wells, two gas injection wells (one of which will be pre-produced), and one disposal well (23 total) at a wellhead spacing of nine feet. Space for up to 40 well slots will be provided. Produced gas will be used for fuel gas and artificial lift, with the balance being re-injected into the reservoir. Seawater will be treated and used to waterflood the Liberty reservoir. Produced water will be commingled with treated seawater and injected as waterflood. A 12-inch Sales Oil Pipeline will transport crude oil to the Badami Sales Oil Pipeline. The offshore portion of the pipeline will be approximately 6.1 miles long and the overland portion will be approximately 1.5 miles long to a tie-in point with the Badami pipeline system.

Associated onshore facilities (Exhibit A) to support this project will include use of existing permitted water sources, ice roads and ice pad construction, and development of a gravel mine site in the Kadleroshilik River floodplain. In addition, existing North Slope infrastructure will be used in support of this project.

1.3 PERMITS AND APPROVALS

The Liberty Development Project is subject to the federal, state, and local approvals listed in Table 1-1. This DPP provides a comprehensive description of the proposed project, including all the information required under 30 CFR 250.204. The DPP incorporates two additional

documents submitted under separate cover: an Oil Spill Contingency Plan (OSCP) and the February 1998 Environmental Report (ER).

Table 1-2 provides a cross reference between this document and the requirements of 30 CFR 250.204.

**TABLE 1-1
PERMITS AND APPROVALS REQUIRED FOR LIBERTY DEVELOPMENT**

| AGENCY | PERMIT / APPROVAL | ACTIVITY / COMMENTS |
|--|---|---|
| <u>Federal Agencies</u> | | |
| All Federal Agencies | NEPA Compliance | NEPA review required before Federal permits can be issued |
| U.S. Army Corps of Engineers | Section 404 / 10 | Island construction, pipeline construction in State waters and lands, onshore pad construction, mine site development |
| Environmental Protection Agency | National Pollutant Discharge Elimination System (NPDES) Individual | Point waste water discharges |
| Environmental Protection Agency | NPDES (General Stormwater Construction/Industrial Activity) | Stormwater drainage - onshore construction and operations |
| U.S. Army Corps of Engineers/Environmental Protection Agency | Ocean Dumping Permit (Section 103 of Marine Protection, Research, and Sanctuaries Act) | Transportation of and discharge of dredged sediments on ocean floor |
| Minerals Management Service | Development and Production Plan | Construction, drilling, and operations |
| Minerals Management Service | Pipeline Application | Pipeline in federal waters |
| Minerals Management Service | Permit to Drill | All wells, including waste injection well |
| Environmental Protection Agency | Part 55 Air Permit | Emissions from island construction and operation, including vessel traffic |
| National Marine Fisheries Service | Incidental Harassment of Marine Mammals (whale and seal) | Marine construction |
| National Marine Fisheries Service | Letter of Authorization for Incidental Take of Marine Mammals (whale and seal) | Construction, drilling, and operations |
| U.S. Fish and Wildlife Service | Letter of Authorization for Incidental Take of Marine Mammals (polar bear and Pacific walrus) | Construction, drilling, and operations |
| National Marine Fisheries Service | Endangered Species Act Consultation | Construction, drilling, and operations |
| U.S. Fish and Wildlife Service | Endangered Species Act Consultation | Construction, drilling, and operations |
| U.S. Coast Guard | Operations Manual | Fuel transfer |

**TABLE 1-1 (CONTINUED)
PERMITS AND APPROVALS REQUIRED FOR LIBERTY DEVELOPMENT**

| AGENCY | PERMIT / APPROVAL | ACTIVITY / COMMENTS |
|--|---|--|
| <u>State Agencies</u> | | |
| Department of Natural Resources, State Pipeline Coordinator's Office | Right-of-Way Lease | Pipeline construction and operations in State waters and lands |
| Department of Natural Resources, Division of Land | Material Sales Contract | Gravel purchase and mining |
| Department of Natural Resources, Division of Land | Miscellaneous Land Use Permit (ice roads) | Construction and operations |
| Department of Environmental Conservation | Oil Discharge Prevention and Contingency Plan | Pipeline operations |
| Department of Environmental Conservation | Section 401 Water Quality Certification | All construction under Corps Section 404 permit (certification) |
| Department of Environmental Conservation | Temporary Water Quality Variance | Marine construction affecting state waters |
| Department of Fish and Game | Title 16 Fish Habitat | Mine site development |
| Division of Governmental Coordination | Coastal Zone Consistency | Construction and operations (certification on all Federal and State permits) |
| <u>Local Agency</u> | | |
| North Slope Borough | Rezoning - Conservation District to Resource Development District | Construction and operations |

**TABLE 1-2
DEVELOPMENT AND PRODUCTION PLAN CROSS REFERENCE TO 30 CFR 250.204**

| 30 CFR 250.204 Requirement | Found in: |
|---|--|
| 250.204 (a)(1) - schedule | Section 2 |
| 250.204 (a)(2) - overview description | entire document |
| 250.204 (b)(1) - geological and geophysical data | Section 3 |
| 250.204 (b)(2) - H2S | Section 3 |
| 250.204 (b)(3) - environmental safeguards | Section 12 and Oil Spill Contingency Plan |
| 250.204 (b)(4) - compliance with lease stipulations | Environmental Report - Section 6.3, plus Environmental Report Supplement |
| 250.204 (b)(5) - reservoir engineering | Section 3 |
| 250.204 (b)(6) - drilling and completion programs | Section 7 |
| 250.204 (b)(7) - new or unusual technology | none proposed for this project |
| 250.204 (b)(8)(i) - offshore and onshore associated activities: | |
| - acreage affected within State | Section 9 |
| - oil and gas transportation (pipeline system) | Section 8 (also see Applications for Pipeline Right-of-Way submitted to the State of Alaska, and Pipeline Right-of-Way Application submitted to MMS) |
| - vessel and aircraft operations | Section 4 |
| 250.204 (b)(8)(ii) - list of proposed drilling fluids | Appendix A (no drilling waste discharges proposed for this project) |
| 250.204 (b)(8)(iii) - waste management | Section 11 |
| 250.204 (b)(8)(iv) - onshore support facilities: | |
| - employment | Section 10 |
| - induced population growth | Environmental Report - Section 5.6.4, plus Environmental Report Supplement |
| - energy consumption | Section 10 |
| - contractors and vendors | Section 10 |
| - air emissions | see Part 55 Air Quality Permit application submitted to the U.S. Environmental Protection Agency |

**TABLE 1-2 (CONT'D)
DEVELOPMENT AND PRODUCTION PLAN CROSS REFERENCE TO 30 CFR 250.204**

| 30 CFR 250.204 Requirement | Found in: |
|--|--|
| 250.204 (b)(8)(v) - existing environment | Environmental Report - Section 4, plus Environmental Report Supplement |
| 250.204 (b)(9) and (10) - sulphur operations | not applicable for this project |
| 250.204 (b)(11) - impact assessment | Environmental Report - Sections 5 and 6, plus Environmental Report Supplement |
| 250.204 (b)(12) - alternatives analysis | Environmental Report - Section 2, plus Environmental Report Supplement |
| 250.204 (b)(13) - Coastal Zone Consistency Certification | Included in February 17, 1998 BPXA letter to MMS |
| 250.204 (b)(14) - air emissions | see Part 55 Air Quality Permit application submitted to the U.S. Environmental Protection Agency |
| 250.204 (b)(15) - suspensions of production | none proposed for this project |
| 250.204 (b)(16) - project contact | cover letter |

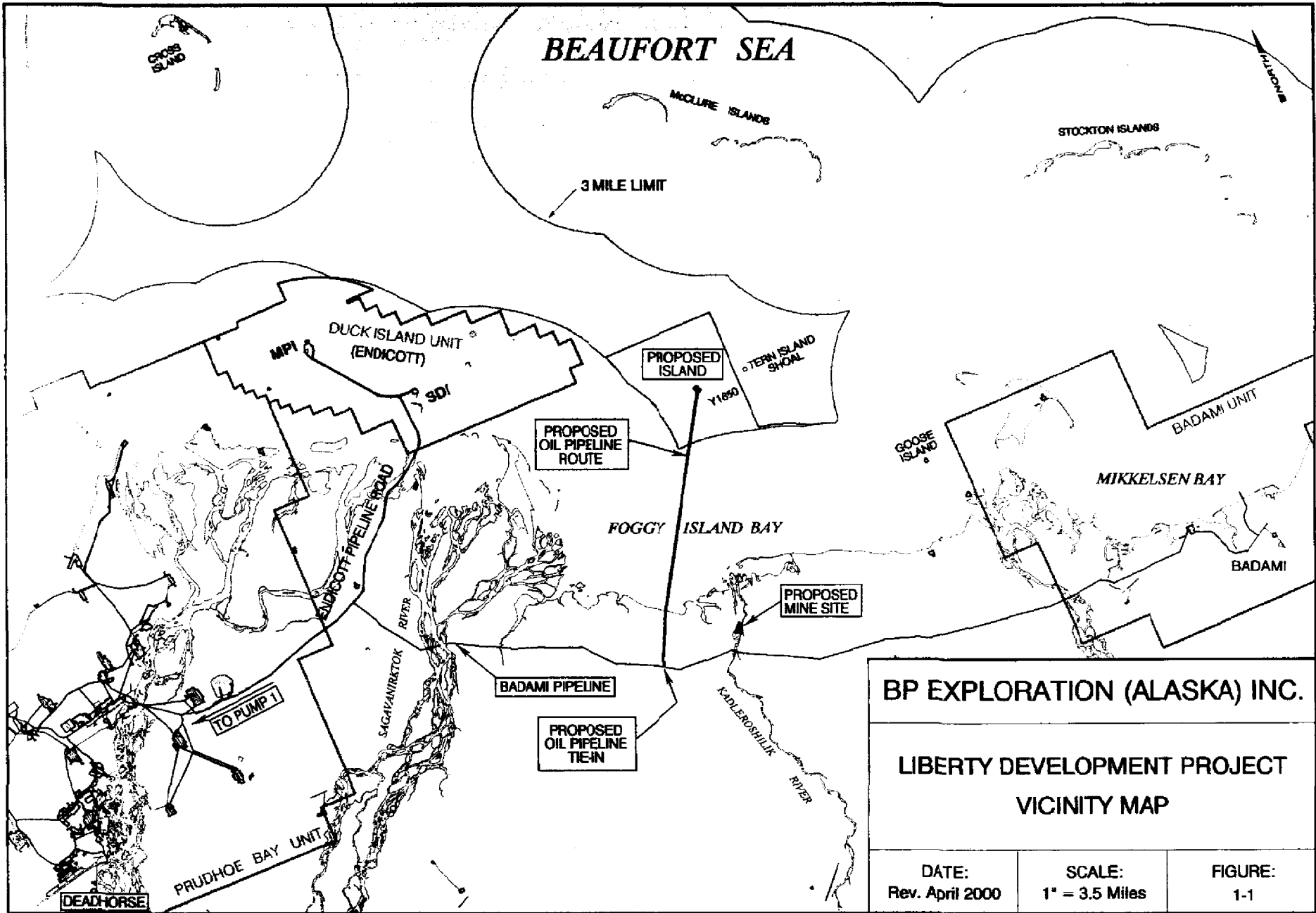

BP EXPLORATION (ALASKA) INC.

**LIBERTY DEVELOPMENT PROJECT
VICINITY MAP**

DATE:
Rev. April 2000

SCALE:
1" = 3.5 Miles

FIGURE:
1-1

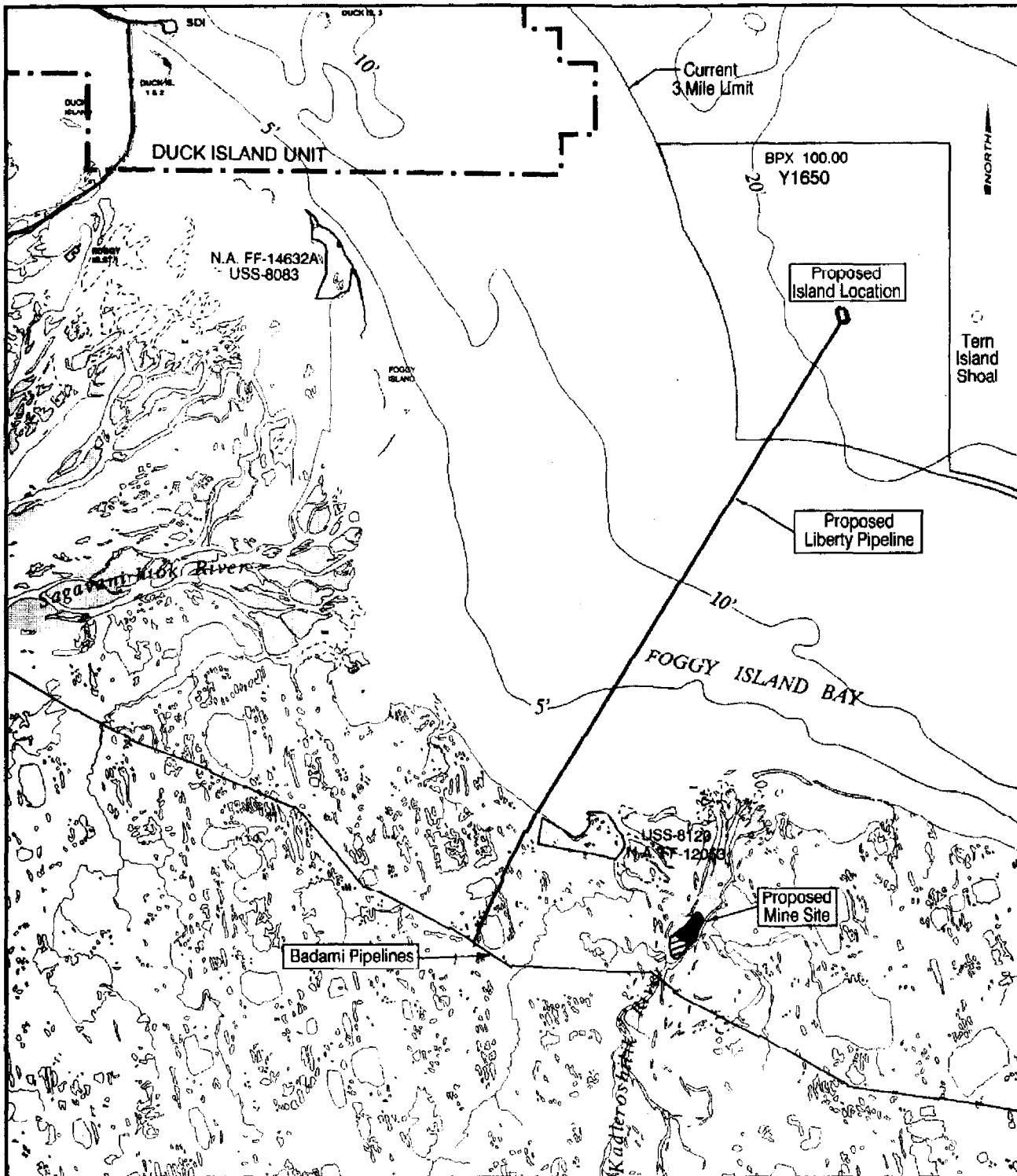

Proposed Pipelines —————

BP EXPLORATION (ALASKA) INC.

**LIBERTY DEVELOPMENT PROJECT
PROPOSED MINE SITE LOCATION**

DATE:
Rev. April 2000

SCALE:
1" = 1.5 Mile

FIGURE:
1-2

2. SCHEDULE

The proposed Liberty development is planned to proceed as three distinct but overlapping phases, as shown on Figure 2-1:

- construction
- drilling
- production operations

For the purposes of this permit application, the first year in which construction activities could occur is designated as Year 1. Subsequent construction and operation years are designated as Year 2, Year 3, etc.

The construction phase will require about 24 months, occurring over a period of three calendar years (from December of Year 1 through November of Year 3). The initial development drilling phase will commence in January Year 3 and is expected to conclude in February Year 5. Drilling operations may be required in subsequent years to accommodate infill development wells and/or existing well workovers. Production operations are expected to begin November Year 3 and continue for the estimated field life of 15 years. Final project abandonment would begin when project facilities are no longer needed.

2.1 CONSTRUCTION

The overall construction strategy for the Liberty project is to use the winter season to its maximum advantage for island and pipeline construction, allowing the use of conventional or adapted onshore construction equipment and techniques, in combination with offshore techniques. Limited island construction will take place in the open water season, along with module delivery and installation. The overall construction schedule is shown in Figure 2-2.

2.1.1 Ice Road Construction

Ice road construction will begin in December Year 1 to support mine site access, gravel hauling, and island construction. The ice road system is shown on Figure 2-3. The rate of this activity will depend on weather, and will proceed faster with lower air temperatures (best when sub-zero degrees Fahrenheit). An ice road system will be reconstructed in December Year 2 to support pipeline construction. Ice roads will naturally melt during breakup in the spring. In subsequent years, an ice road system will be rebuilt as needed to support project operations.

2.1.2 Mine Site Development

Development of the Liberty mine site, located in the Kadleroshilik River floodplain, will be completed in two annual phases. The first phase will begin in January Year 2, and the second phase in January Year 3. In both of these years, the general sequence of activities for mine site

development includes removal of snow and ice, removal and stockpiling of unusable material, pit excavation and gravel hauling, backfill of unusable material into the pit, breach construction, and flooding to reclaim the pit. Additional reclamation activities will be conducted after the pit is flooded. A Mining and Reclamation Plan has been submitted under separate cover to the State of Alaska, Department of Natural Resources, Division of Land, for review and approval.

2.1.3 Island Construction

Liberty will be a stand-alone, self-contained, offshore drilling and production facility located on a gravel island which will include all support infrastructure and necessary facilities. Gravel hauling and placement will occur during the winter construction season.

Island construction will commence as soon as the ice road from the mine site to the island site has been completed. Gravel will be hauled from the Kadleroshilik River mine site over the ice road. The gravel haul will continue for about 45 to 60 days, and by mid-April all gravel should be in place. Slope protection installation will follow, beginning before breakup and continuing into July. The pile-driven sheetwall for the dock will be installed by the open water season. Well conductors will also be driven in this timeframe. Precast foundations will be poured at an off-site location and trucked to the island. Alternatively, foundations may be formed and poured on-site, or pilings may be used for building foundations. Foundation installation will require approximately 30 days and will be complete by mid-August. Remaining island construction work will be completed in early to mid-August prior to arrival of the Year 2 sealift. Foundation and sheetwall materials will be transported to the island by ice road or by barge.

Concrete products (mats and precast foundations) will be manufactured at existing facilities, most likely in the Deadhorse area. Gravel and water from existing permitted sources will be used in the manufacturing process.

2.1.4 Pipeline Construction

Pipeline construction is planned as a winter Year 3 operation. The pipeline will extend from the island to a tie-in with the Badami Pipeline system. Pipeline construction will start in January Year 3 and be completed in May Year 3. The proposed winter Liberty offshore pipeline installation techniques are essentially adaptations of onshore construction and installation technology utilizing conventional construction and pipe laying equipment.

As shown on Figure 2-2, the offshore and onshore pipeline segments will be simultaneously installed in two separate construction spreads. The onshore sequence of activities includes VSM installation, placement of the pipeline on the VSMS, and construction of the Badami tie-in. Offshore, construction will progress from shallower water to deeper water in multiple construction spreads. The pipeline trench will be excavated, pipelines laid in the trench, and the trench backfilled. The offshore pipeline is about 6.1 miles long, and work will be done from thickened ice using conventional excavation and other construction equipment. The onshore section is approximately 1.5 miles long, and will be built using conventional North Slope construction techniques.

Hydrotesting of the pipeline will be completed by May Year 3. The pipeline will be commissioned in November Year 3, during facility start-up.

2.1.5 Fabrication

Process facilities for the Liberty Project will primarily be prefabricated sealift modules shipped to the island site and installed. Some fabrication and a majority of the assembly will occur at a yard in Anchorage, with delivery by barge during the open water season. Most of the vessel and skid fabrication will be either on the Gulf Coast or in Anchorage, with skids being assembled into process modules at the Port of Anchorage.

2.1.6 Assembly

Infrastructure facilities, including the permanent living quarters (PLQ)/utility module, warehouse, tanks, and grind and inject facility (GIF) will be assembled in Anchorage, and then fully tested and commissioned. The larger process/seawater treatment/power, gas compression, warehouse, and permanent living quarters/utility modules will be assembled in Anchorage with most of the hydrotesting and functional checkout completed before shipment to the North Slope. After system testing, each section will be moved to a barge via rubber tired transporters, which will also be used for off-loading at Liberty Island.

Following the sealift, process module sections will be set and the tie-ins between the sections completed. Piping and electrical connections will be made from the support facilities to the Process Module, including the utility module, wellheads, and the onshore pipeline. The sealift containing the process modules will arrive approximately August 15, Year 3 and begin off-loading the major process and infrastructure modules.

2.1.7 Facilities Installation

Module fabrication and assembly will commence in Year 1 and be completed by July Year 3 to accommodate the sealifts in Year 2 and Year 3. Infrastructure facilities will be sealifted in July/ August Year 2 and will be installed and operational by September-October Year 2. The facilities sealift will arrive at the Liberty location in August Year 3.

2.2 DRILLING

The drilling rig and associated equipment will be mobilized to the Liberty Island by barge in August-September Year 2. Drilling startup is scheduled for January Year 3 when an ice road will be available for transportation of drilling waste from the first well to an onshore disposal site. Drilling will continue until August of Year 3, when the facilities sealift arrives on the island. After Liberty facilities are commissioned (approximately November Year 3), drilling will resume, and will continue until approximately February Year 5, when all the wells will be drilled. Each spring and fall sufficient drilling consumables will be stockpiled on the island to allow drilling through the broken ice periods.

The first well to be drilled will be the waste disposal injection well. Cuttings and waste mud from this well will be hauled to an existing onshore facility for disposal. As an alternative, cuttings can be temporarily staged on the Liberty island for later disposal. Once the disposal well and injection facilities are commissioned, waste from all other wells will be injected into the disposal well.

The proposed drilling sequence for production, water and gas injection wells is provided in Table 2-1.

2.3 OPERATIONS

Production operations are scheduled to commence on completion of the facilities installation, hook-up and commissioning activities in October Year 3. Initial production rates are expected to be in the range of 30 to 35 thousand barrels of oil per day (MBOD), rapidly increasing to the peak production rate of 65 MBOD as additional production wells are drilled. This peak production rate represents the current maximum average capacity of Liberty production facilities. The projected Liberty production profile is provided in Figure 2-4. This production profile shows average annual production rates of about 58.5 MBOD, less than the plant capacity of 65 MBOD, due to plant downtime as a result of maintenance shutdowns, equipment reliability, or pipeline slowdowns. Note that Section 6.5 discusses an option BPXA is considering to increase plant capacity to 75 MBOD. The economic field life is currently estimated to be approximately 15 years. Accordingly, the facilities/pipeline have a minimum operational economic life of 20 years. Note that this operational economic life is not the same as design life - project design criteria used for the pipeline, island, and facilities considered extreme environmental events (e.g. wave, ice, storm, seismic conditions, etc.).

During the initial production phase it is likely that simultaneous production, drilling and minor construction activities will be ongoing. Special procedures and precautions will be adopted to assure safety of personnel and plant during high-activity periods.

TABLE 2-1
PROPOSED DRILLING SEQUENCE

| Well Numb | Well Type | Preliminary Well Schedule | | |
|-----------|------------------------|---------------------------|------------------------|----------------------------|
| | | Duration (day) | Start | End |
| | Waste Injectio | 28 | January 1, Year 3 | January 29, Year 3 |
| 1 | Oil Producer | 33 | January 29, Year 3 | March 3, Year 3 |
| 2 | Gas Injector | 38 | March 3, Year 3 | April 10, Year 3 |
| 3 | Oil Producer | 33 | April 10, Year 3 | May 13, Year 3 |
| 4 | Oil Producer | 31 | May 13, Year 3 | June 13, Year 3 |
| 5 | Oil Producer | 32 | June 13, Year 3 | July 15, Year 3 |
| | <i>drilling hiatus</i> | | <i>July 15, Year 3</i> | <i>November 15, Year 3</i> |
| 6 | Water Injector | 34 | November 15, Year 3 | December 19, Year 3 |
| 7 | Oil Producer | 28 | December 19, Year 3 | January 16, Year 4 |
| 8 | Oil Producer | 27 | January 16, Year 4 | February 12, Year 4 |
| | Water Injector | 29 | February 12, Year 4 | March 12, Year 4 |
| 10 | Water Injector | 30 | March 12, Year 4 | April 11, Year 4 |
| 11 | Oil Producer | 27 | April 11, Year 4 | May 8, Year 4 |
| 12 | Water Injector | 26 | May 8, Year 4 | June 3, Year 4 |
| 13 | Oil Producer | 23 | June 3, Year 4 | June 26, Year 4 |
| 14 | Oil Producer | 23 | June 26, Year 4 | July 19, Year 4 |
| 15 | Oil Producer | 30 | July 19, Year 4 | August 18, Year 4 |
| 16 | Water Injector | 25 | August 18, Year 4 | September 12, Year 4 |
| 17 | Oil Producer | 23 | September 12, Year 4 | October 5, Year 4 |
| 18 | Oil Producer | 23 | October 5, Year 4 | October 28, Year 4 |
| 19 | Oil Producer | 21 | October 28, Year 4 | November 18, Year 4 |
| 20 | Oil Producer | 21 | November 18, Year 4 | December 9, Year 4 |
| 21 | Water Injector | 24 | December 9, Year 4 | January 2, Year 5 |
| 22 | Gas Injector | 32 | January 2, Year 5 | February 3, Year 5 |

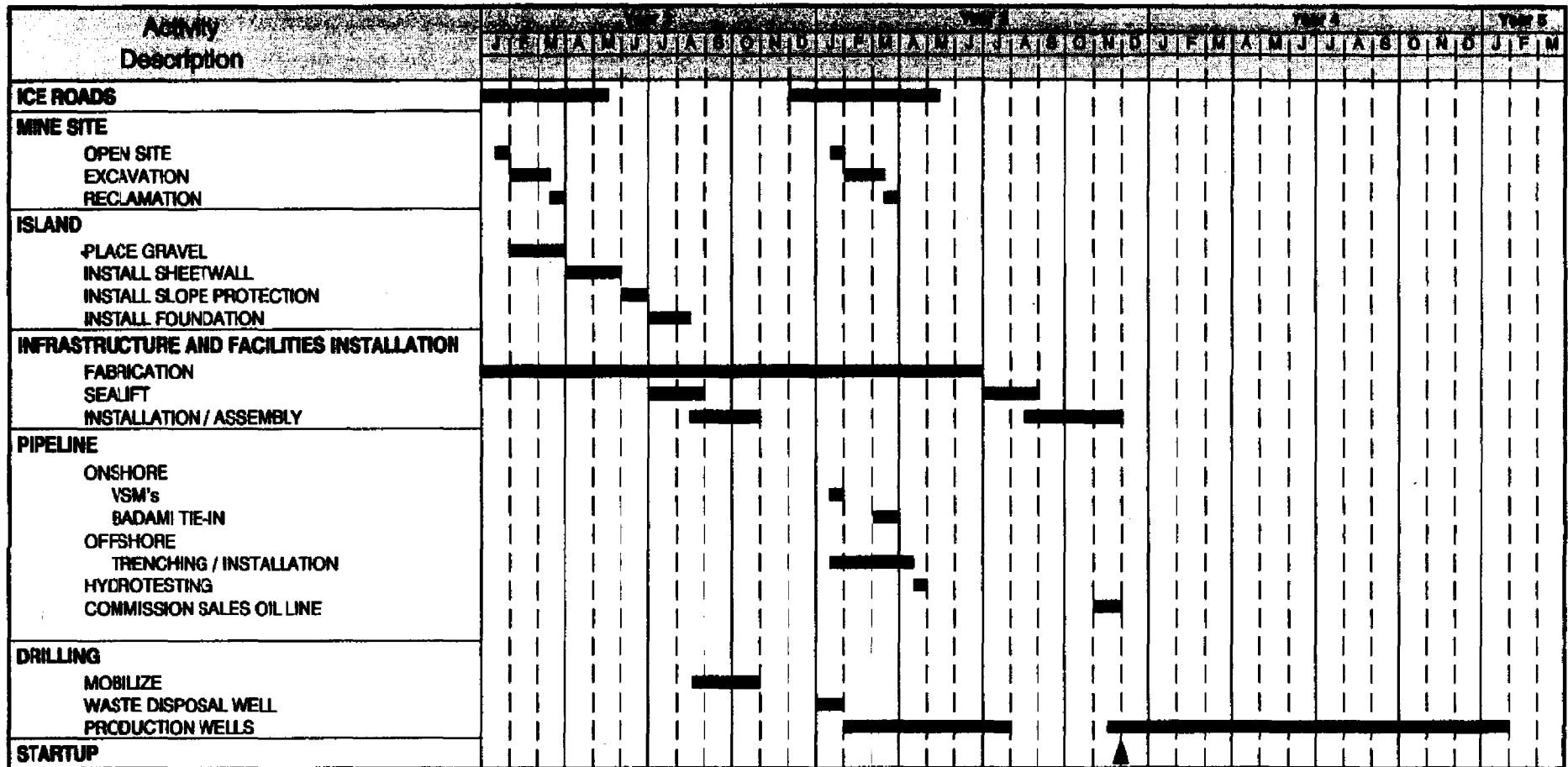

BP EXPLORATION (ALASKA) INC.

**LIBERTY DEVELOPMENT PROJECT
OVERALL CONSTRUCTION
SCHEDULE**

DATE:
Rev. April 2000

SCALE:
N/A

FIGURE:
2-2

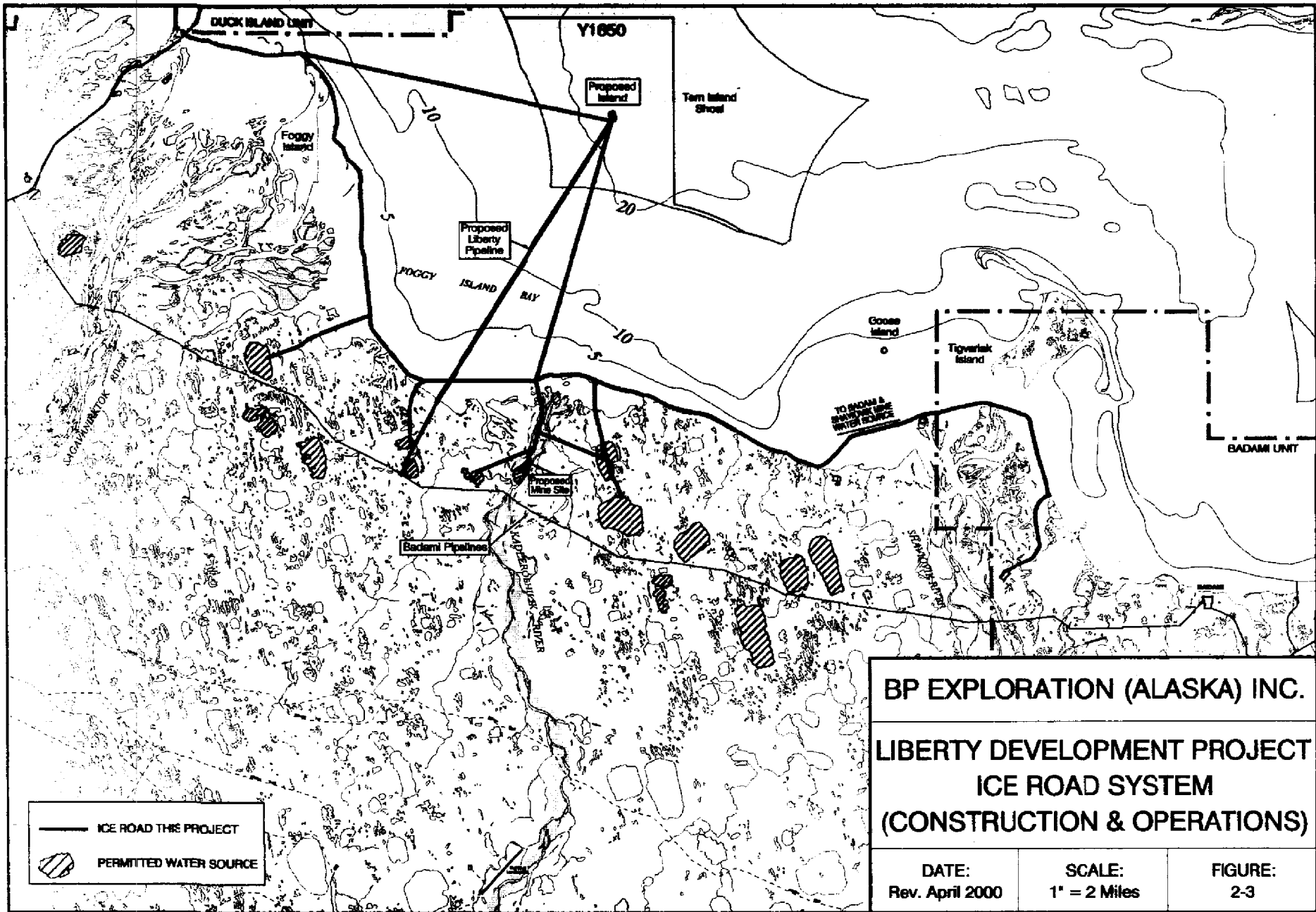

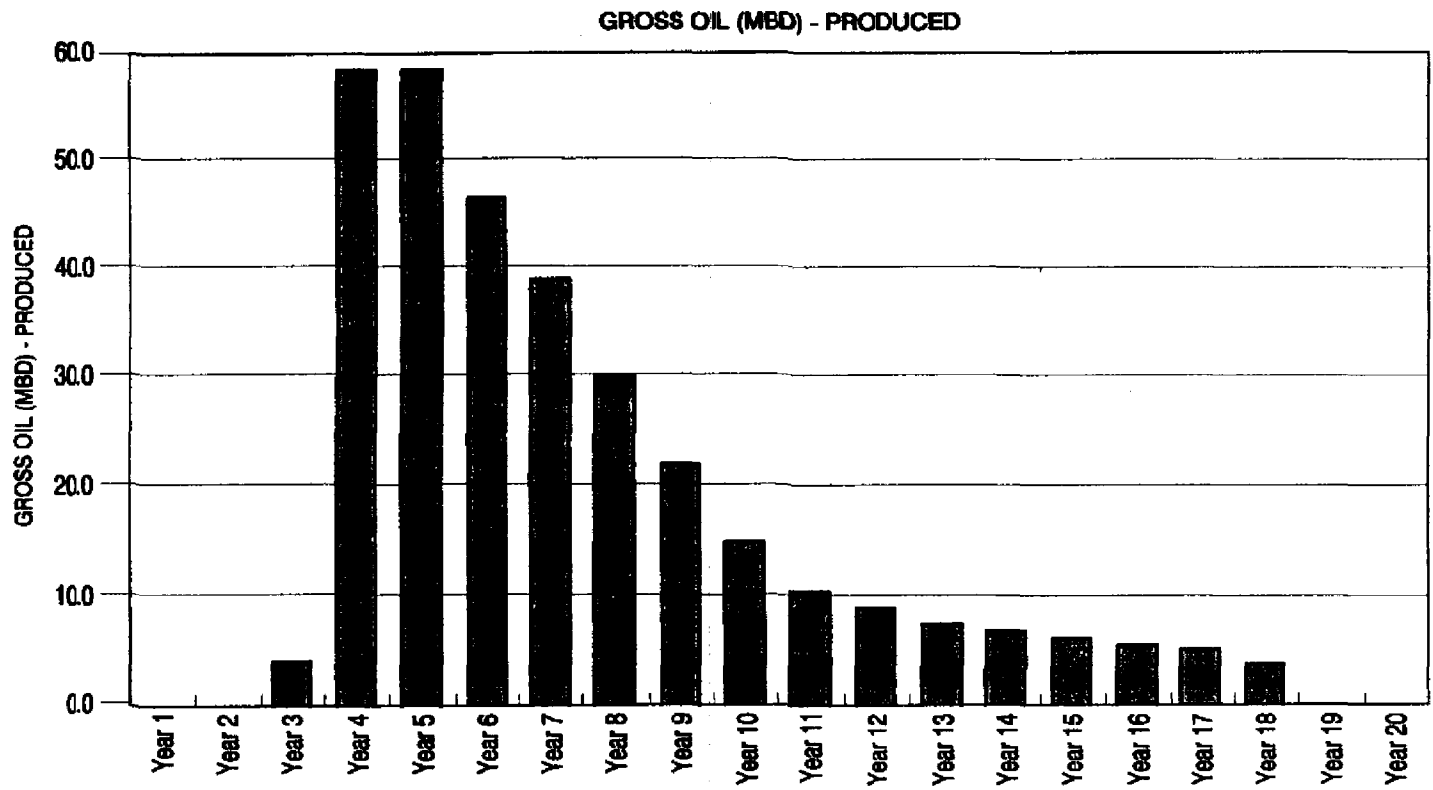

■ GROSS OIL (MBD) - PRODUCED

BP EXPLORATION (ALASKA) INC.

**LIBERTY DEVELOPMENT PROJECT
PRODUCTION PROFILE**

DATE:
Rev. April 2000

SCALE:
N/A

FIGURE:
2-4

3. GEOLOGY AND RESERVOIR DEVELOPMENT

3.1 GENERAL RESERVOIR DESCRIPTION

The Liberty # 1 well confirmed the presence of hydrocarbons on Federal lease OCS-Y-1650 in March 1997. The discovery is located about five miles offshore in Foggy Island Bay, southeast of the Duck Island Unit (Figure 3-1). Three other wells exist in the area (Tern Island #1A, #2A and #3) and provide additional data related to the discovery. A three dimensional seismic survey covers the accumulation and is used to map the top of the reservoir and define the prospect limits. The well and seismic data yield an oil reserve estimate of approximately 120 million barrels of recoverable oil.

The Liberty #1 well established the presence of producible hydrocarbons within the Kekiktuk Zone 2 reservoir. The Liberty accumulation is similar to the nearby Endicott Field, operated by BPXA. Both fields have structural-stratigraphic traps involving north-west trending faults and reservoir truncation by the Lower Cretaceous Unconformity (LCU). The Liberty Field is bounded to the south-west by Fault "A" (or the "Tigvariak" Fault), and to the north-east by Fault "B" (Figures 3-1 and 3-2).

The Zone 2 reservoir is in truncation across the entire Liberty field and the LCU depth map represents top reservoir structure in the field area (Figure 3-2). The LCU truncates younger strata south of Fault "A" and older strata north of Fault "B" (Figure 3-3). The structure dips regionally to the south-east and the updip trap is formed by reservoir truncation at the LCU (Figure 3-4).

Tern Island #3 and Liberty #1 encountered a "tar mat" in the Zone 2 reservoir which lies below the base of the movable oil column. In the Liberty #1 well, the tar mat lies at the base of Zone 2, with an overlying oil column to the top of the reservoir. No gas was encountered in the well, but pressure data indicates the presence of a gas cap, similar to the Endicott Field. In Tern Is. #3, a tar mat exists from the top of the Zone 2 reservoir, overlying a water leg in the lower portion of the reservoir (about 11,050 feet true vertical depth [TVD] and deeper). No movable hydrocarbons are evident in the Tern Is. #3 well. Top tar represents the base of producible hydrocarbons in the Liberty Field and this limit is constrained by the Liberty #1 and Tern Is. #3 wells. This type of basal "tar mat" is common in North Alaska oil fields, such as the Endicott and Prudhoe Bay Fields. The top of the tar mat is not structurally flat in these fields and variations of several hundred feet are observed.

Experience with developing the Endicott Field allows BPXA to determine the most efficient method to maximize oil recovery in the Liberty Field. Twenty-three total wells will be drilled for initial development, including 14 production wells, six water injection wells, two gas

injection wells (one of which will be pre-produced), and one disposal well (Figure 3-2 and Table 3-1). All of the wells will be drilled from one offshore gravel island location. The producer to injector ratio (2.3:1) is lower than Endicott's 3:1 ratio. This is due to an increase in the number of water injectors necessary to maintain reservoir pressure and improve recovery. The field will be developed with two gas injectors located near the structural crest and six water injectors located downdip to form a partial peripheral waterflood (i.e. a waterflood restricted to the downdip portion of the field). All of the produced water will be treated and reinjected with additional volumes of sea water. Approximately 90 percent of the produced gas will be reinjected, with the remaining 10 percent used as fuel to power facilities.

Due to the relatively simple structure and high quality nature of the Liberty reservoir, producers can be concentrated locally in regions of high net pay. The initial Liberty full field model includes phasing in the start-up of the producers and injectors. With pressure maintenance a primary objective in the Liberty reservoir management, wells will be brought on line by alternating between producers, water injectors, and gas injectors as needed.

The Tern Island #1A and #2A wells have proven that there is one or more Zone 1 accumulations north of Fault "B" that are not in fluid communication with the Liberty Field. Tern Is. #2A flowed 87 barrels of oil per day from Zone 1 at a depth of about 11,400' TVDss. This is about 350 feet deeper than the base of tar in Tern Is. #3. Tern Island #1A flowed oil from a broad interval that is deeper than known water in the Liberty Field (about 10,750' to 11,400' TVDss). It is uncertain if the Zone 1 oil tested in Tern Is. #1A and Tern Is. #2A are part of the same accumulation. It is possible that Fault "B" separates the Tern Is. #1A/#2A Zone 1 accumulation(s) from Liberty, or it is possible the Zone 1 hydrocarbons are stratigraphically trapped in thin discontinuous sands and the trap is independent from the faulting. Further drilling will be required to understand the nature of the Zone 1 accumulation(s) and assess the possibility for commercial development. BPXA proposes evaluating the Zone 1 accumulation(s) from the Liberty Field development island, where it can be appraised at reasonable costs.

The proposed development plan includes provisions for evaluating additional productivity of the reservoir as new well information is obtained. The major design feature to allow for taking advantage of additional information gained from this evaluation is the inclusion of more well slots than needed for initial development of the currently delineated Liberty reservoir. Those slots could be used in the future for appraisal or development well drilling. If other economically recoverable prospects are defined by drilling from this island, the plan would be to use existing island infrastructure for production of those hydrocarbons. In effect, this could extend the life of the project facilities by continuing production over a longer time period than envisioned for the Liberty prospect alone.

3.2 SHALLOW HAZARDS

In summer of 1997, BPXA conducted a shallow hazards survey of the proposed development area. The geophysical systems used for the survey included a high resolution

seismic profiling (CDP) system, an intermediate seismic system, a high frequency seismic profiler, digital side scan sonar, and digital fathometer.

No shallow hazards were discovered as a result of that survey. Geophysical data and the interpretive results were submitted to the MMS under separate cover in February 1998, prepared in accordance with specification NTL 89-2, Section G.

3.3 HYDROGEN SULFIDE

Minor amounts (<10 ppm) of hydrogen sulfide (H₂S) were encountered while testing the Liberty #1 well. BPXA will follow standard safety procedures typically used on the North Slope of Alaska for this level of hazard. These procedures will be described in a H₂S Contingency Plan to be submitted to MMS for review and approval prior to the start of drilling operations.

TABLE 3-1
ESTIMATED WELL DEPTHS

| Well # | Type | TVD (feet) | Departure (feet) | MD (feet) |
|--------|----------------|------------|------------------|-----------|
| 1 | Oil Producer | 11,050 | 1,800 | 11,860 |
| 2 | Gas Injector | 10,600 | 9,500 | 14,875 |
| 3 | Oil Producer | 11,050 | 1,700 | 11,815 |
| 4 | Oil Producer | 10,950 | 4,700 | 13,065 |
| 5 | Oil Producer | 11,050 | 1,400 | 11,680 |
| 6 | Water Injector | 11,300 | 8,100 | 14,945 |
| 7 | Oil Producer | 10,950 | 4,000 | 12,750 |
| 8 | Oil Producer | 11,000 | 1,000 | 11,450 |
| 9 | Water Injector | 11,100 | 3,300 | 12,585 |
| 10 | Water Injector | 11,000 | 5,500 | 13,475 |
| 11 | Oil Producer | 10,800 | 7,500 | 14,175 |
| 12 | Water Injector | 11,100 | 4,500 | 13,125 |
| 13 | Oil Producer | 11,200 | 4,800 | 13,360 |
| 14 | Oil Producer | 10,900 | 6,200 | 13,690 |
| 15 | Oil Producer | 11,150 | 2,900 | 12,455 |
| 16 | Water Injector | 11,150 | 6,000 | 13,850 |
| 17 | Oil Producer | 10,950 | 4,800 | 13,110 |
| 18 | Oil Producer | 10,950 | 3,200 | 12,390 |
| 19 | Oil Producer | 10,950 | 4,300 | 12,885 |
| 20 | Oil Producer | 10,800 | 7,800 | 14,310 |
| 21 | Water Injector | 11,300 | 6,100 | 14,045 |
| 22 | Gas Injector | 10,750 | 8,300 | 14,485 |

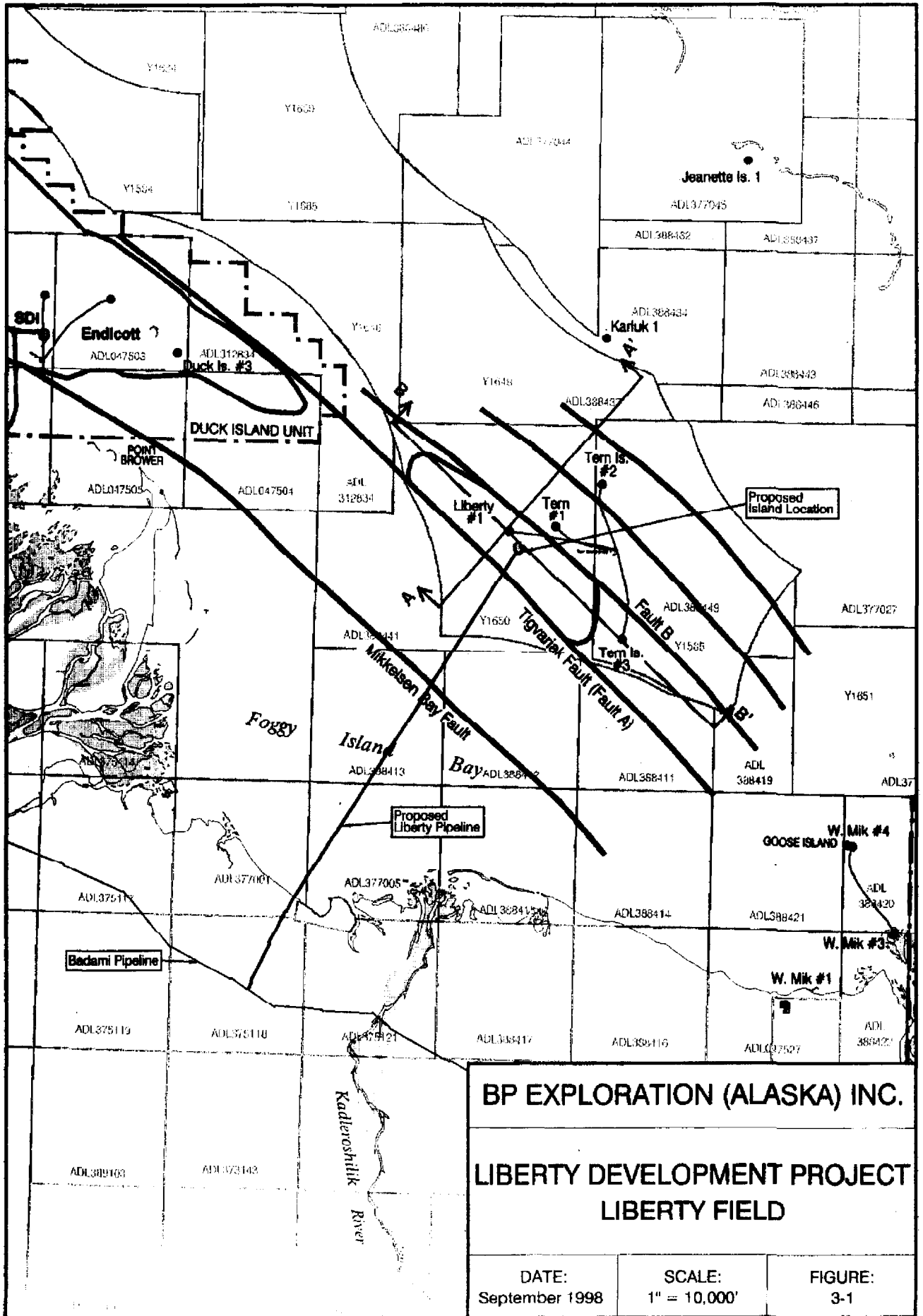

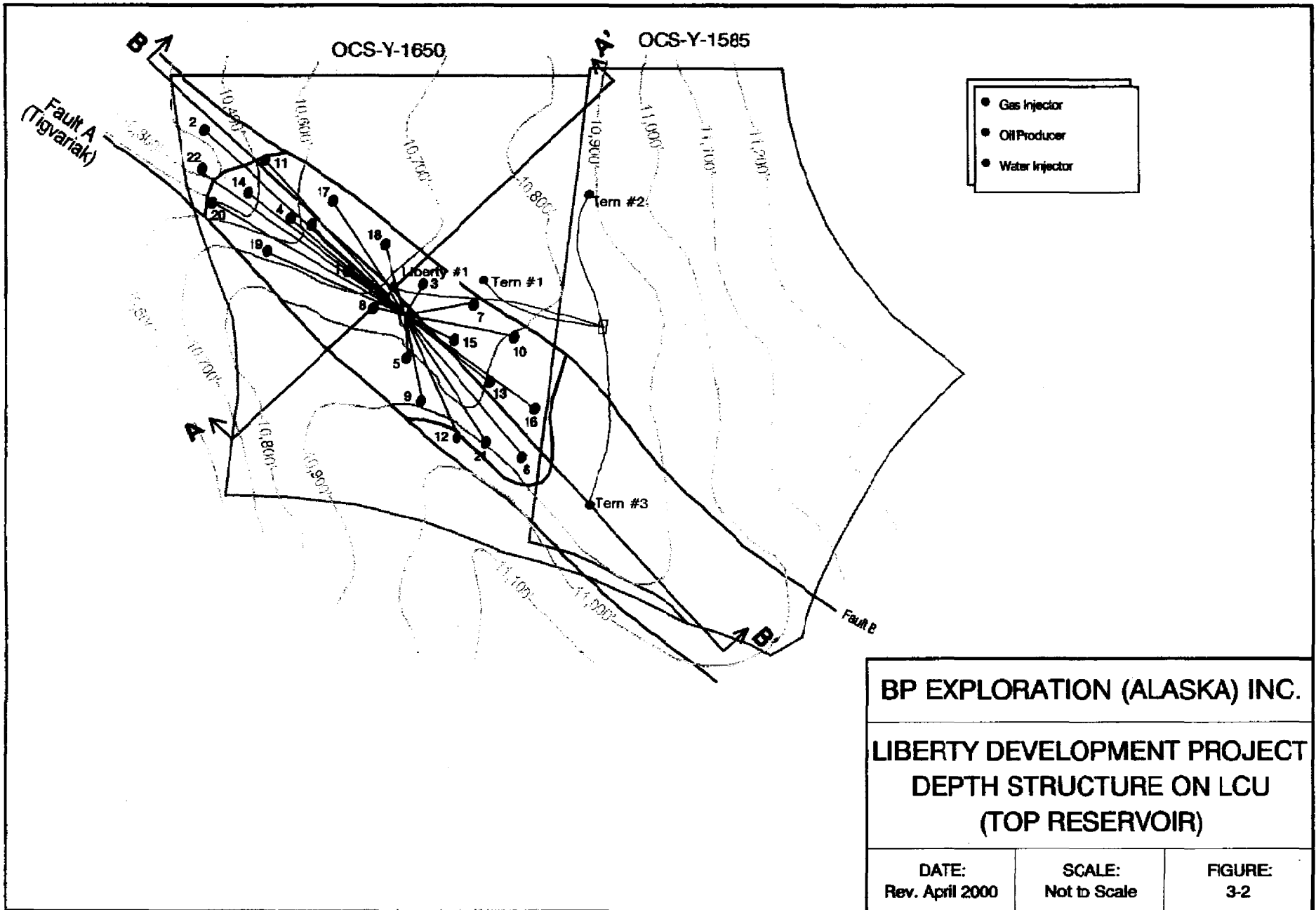

| | | |
|---|-------------------------------|-----------------------|
| BP EXPLORATION (ALASKA) INC. | | |
| LIBERTY DEVELOPMENT PROJECT DEPTH STRUCTURE ON LCU (TOP RESERVOIR) | | |
| DATE: Rev. April 2000 | SCALE: Not to Scale | FIGURE: 3-2 |

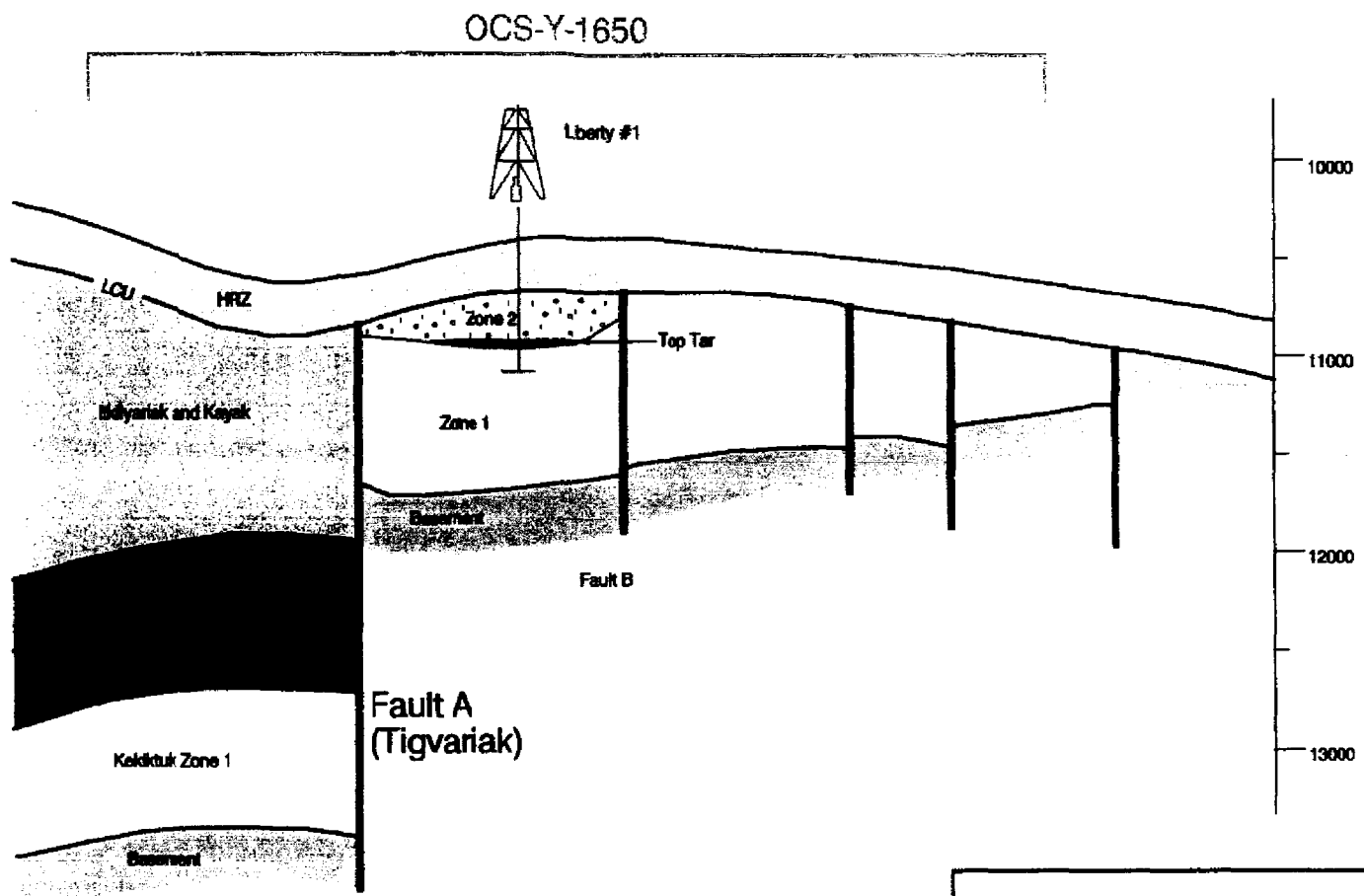

Section A - A'

| | | |
|--|------------------------|----------------|
| BP EXPLORATION (ALASKA) INC. | | |
| LIBERTY DEVELOPMENT PROJECT PRODUCTION PLAN STRUCTURE CROSS - SECTION A-A' | | |
| DATE: September 1998 | SCALE: Not to Scale | FIGURE: 3-3 |

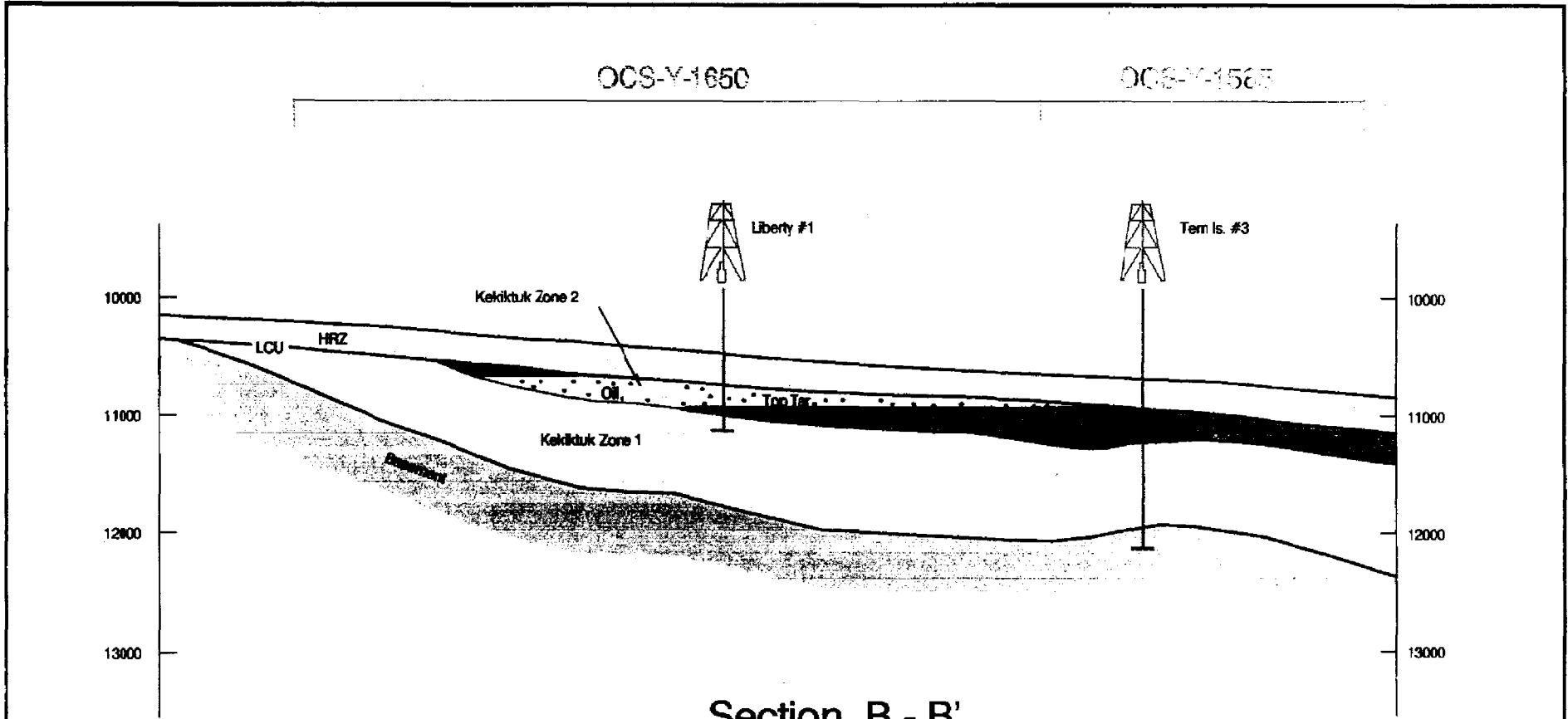

Section B - B'

| | | |
|--|------------------------|----------------|
| BP EXPLORATION (ALASKA) INC. | | |
| LIBERTY DEVELOPMENT PROJECT PRODUCTION PLAN STRUCTURE CROSS - SECTION B-B' | | |
| DATE: September 1998 | SCALE: Not to Scale | FIGURE: 3-4 |

4. PROJECT ACCESS

4.1 ACCESS NEEDS AND OPTIONS

Liberty project transportation needs include the ability to safely transport personnel, supplies, and equipment to and from the site during construction, drilling, and operations in an offshore environment. During construction, large quantities of pipe, gravel, and heavy modules will need to be moved to the site. Drilling operations will require movement of pipe materials, chemicals, and other supplies to the island. During ongoing field operations, equipment and supplies will need to be transported to the site. All phases of construction, drilling, and operation will require movement of personnel to and from the Liberty area. Table 4-1 summarizes basic project transportation needs and identifies the frequency of those needs.

The Liberty area is remote from existing North Slope infrastructure; the nearest transportation facilities are located in the Endicott and Prudhoe Bay units, about seven to 10 air miles west of the site. In the project development process, various options were identified for accessing the site and for moving equipment, supplies, and personnel to and from the site. Several different modes of currently available transportation were considered. The following sections describe the basic features and limitations of each mode. Figure 4-1 shows seasonal limitations associated with operation of each mode of transportation.

4.1.1 Air Access

Year round helicopter access to the Liberty area is planned, and a helicopter landing site is designed on the island. Air operations can be limited by weather conditions and by aircraft availability. In general, air access will be used for movement of personnel and foodstuffs, and for emergency movement of supplies or equipment. BPXA will avoid direct overflights of Howe Island during the Snow Goose nesting and brood-rearing period (one mile separation distance). In addition, helicopters will fly at an altitude of at least 1,500 feet, except for take-offs, landings, and as dictated for safe aircraft operations. BPXA plans ongoing coordination with the resource agencies to identify any other needed air operations constraints.

4.1.2 Ice Roads

Ice roads are commonly used on the North Slope for winter travel from late December through mid-April. Roads across the sea ice are constructed by grading the sea ice or thickening it with water as needed to create a surface suitable for vehicular movement. Floating ice roads, such as planned for access to the Liberty Island, cannot be used for movement of extremely heavy modules.

TABLE 4-1

LIBERTY PROJECT TRANSPORTATION NEEDS

| PROJECT ACCESS NEEDS | FREQUENCY | | |
|--|-----------|--------------|----------|
| | ONGOING | INTERMITTENT | DISCRETE |
| Haul gravel from mine site to construction site | | | X |
| Haul pipeline construction materials | | | X |
| Transport production modules | | | X |
| Spill response - mobilize equipment and personnel to onshore and offshore locations as needed for containment and cleanup (for details see OSCP) | X | | |
| Transport supplies and equipment to the site. | X | | |
| Drill rig transport. | | X | |
| Personnel transport. | X | | |
| Waste handling. Includes hauling back domestic waste, waste stored in barrels, and scrap. In initial years, drilling wastes may also be hauled back. Note that most wastes will be disposed of on site by injection. | X | | |
| Capability for emergency transport of relief rig (for details see OSCP) | X | | |

As described in Sections 2 and 9, a system of ice roads will be built to support project construction, and, in subsequent years, to support drilling and production operations.

4.1.3 Marine Access

Barges and other boats can travel from the Prudhoe Bay area to the Liberty area in the open water season, and will be generally chartered from a local supplier on an as-needed basis to move equipment and supplies.

Seagoing barges will be used to transport large modules and other supplies and equipment from Southcentral Alaska. Movement of these barges around Point Barrow is limited to a short period from mid-August through mid- to late September. A dock for offloading modules onto the island is incorporated into the island design.

To minimize the potential for conflicts with subsistence users, marine vessels transiting between Prudhoe Bay or Endicott to the project area will travel shoreward of the barrier islands.

4.2 ACCESS BY PROJECT PHASE

This section outlines modes of access to the island and the pipeline corridor during each phase of the project (construction, drilling, and production operations). Air, ice road, and marine access will all be required for the Liberty project. The OSCP contains additional detailed information about access logistics and equipment requirements needed to support spill response.

Emergency evacuation will be via helicopter or vessels. Prior to starting construction, a detailed evacuation plan will be completed addressing the construction, drilling, and operations phases of the project.

4.2.1 Construction Access

Liberty construction will begin in December Year 1, and continue through project start-up in November Year 3. An offshore and onshore ice road system will provide access for winter island and pipeline construction (Figure 2-3). Estimated transportation requirements associated with the construction phase of the project are summarized in Table 4-2. This table describes the estimated number of trips required to support the two year construction program, broken out by season and by mode of operation.

During the period January through April or May in the years Year 2 and Year 3, construction workers will access the project area from existing facilities via existing gravel roads and the ice road system. Construction vehicles will be staged at the construction site. Helicopter use during this period may also occur.

By spring breakup, all materials needed to support limited ongoing construction will have been transported to the island over the ice road system. Personnel will access the island during breakup via helicopter; after breakup crew boats may be used.

During the open water season, personnel will continue to access the island via helicopter or crew boat. Any needed construction materials and supplies will be mobilized to the site by barge from West Dock, East Dock, or Endicott. In addition, modules will be sealifted to the site

by ocean-going barge in August Year 2 and Year 3. Two or three barges will be needed to complete the sealift operation. After startup in November Year 3, the number of helicopter flights needed for personnel transport will be reduced.

During breakup and summer Year 3, access to the pipeline corridor will be via helicopter. In the period between completion of hydrotesting and facilities start-up, an estimated one to two flights per week will be required for access to the pipeline corridor, including personnel and equipment access to the tie-in area. Equipment located at the pipeline tie-in location will be accessed by helicopter or approved tundra travel vehicles to minimize harm to the tundra.

In the summer of Year 3, a barge camp may be moored at the island location. If this option is implemented, it would have the effect of reducing traffic associated with personnel transport, as shown in Table 4-2.

4.2.2 Drilling and Production Operations Access

A drill rig and consumables will be mobilized to the site by barge in the summer of Year 2. Mobilization of a rig from most onshore North Slope locations would involve loading the rig onto a barge at West Dock at Prudhoe Bay. In this case, there is a slight possibility that maintenance dredging could be required at West Dock (Dock Head #2) to allow docking of the barge used to transport the rig. This dredging operation would probably consist of using a Crowley Screed barge to back-drag the area at a maximum 6-foot depth, with no over draft dredging. Based on estimates used to permit previous dredging programs at this location, the area to be dredged would extend about 600 feet seaward of Dock Head 2, and about 25 to 100 cubic yards of material would be dredged. Maintenance dredging might also be required if the drill rig is demobilized back across West Dock to an onshore location.

Subsequently, the drilling operation will be resupplied by summer barge or winter ice road travel. This resupply will be integrated with resupply needed to support production operations. Estimated transportation requirements associated with the drilling and production operations phase of the project are summarized in Table 4-2. This table describes the estimated number of trips required to support drilling and production operations, broken out by season and by mode of operation.

After project start-up, activities on the island will include routine production operations, maintenance, and drilling. By February Year 5, drilling is scheduled to be completed, and only production-related site activities will occur. In later stages of the project, infill drilling or required rig workovers could occur. In this case, transportation requirements would be similar to levels experienced during development drilling.

Personnel will be transported to and from the island on a regular rotation. Each winter, ice roads will be used to resupply needed equipment, parts, foodstuffs, and products, and for hauling wastes back to existing facilities. During summer, barge trips will be required between Prudhoe Bay/Endicott and the island for resupply.

During operations, BPXA plans to conduct aerial helicopter surveillance of the offshore and onshore pipeline corridor at least once per week. A helicopter landing site will be

constructed on the tie-in pad and at the landfall pad to allow routine access without damage to the surrounding tundra. During routine production and maintenance operations, visits to the pipeline pads will be infrequent and unlikely to average more than once per week.

Table 4-2
Estimated Liberty Transportation Requirements

| Access Type | Construction | | | Drilling and Production Operations | | |
|----------------------------------|---|-------------------|-------------------|---|------------------|--|
| | Summer | Breakup/Freezeup | Winter | Summer | Breakup/Freezeup | Winter |
| <u>With Camp Barge</u> | | | | | | |
| Aircraft | Year 1: 10-20 daily Year 2: 5-10 daily | 10-20 trips daily | 10-20 trips daily | 3 trips weekly | 1 trip daily | 3 trips weekly |
| Surface | - | - | 400 trips daily | - | - | 400 per season during drilling; 100 per season post-drilling |
| Marine | 80 local round trips in Year 1; 120 local round trips in Year 2; plus sealift, rig mobilization, and barge camp mobilization | - | - | 4-5 trips per month during drilling; 4-5 trips per season post-drilling | - | - |
| <u>Without Camp Barge</u> | | | | | | |
| Aircraft | 10-20 trips daily | 10-20 trips daily | 10-20 trips daily | 3 trips weekly | 1 trip daily | 3 trips weekly |
| Surface | - | - | 400 trips daily | - | - | 400 per season during drilling; 100 per season post-drilling |
| Marine | 100 local round trips in Year 1; 150 local round trips in Year 2; plus sealift, rig mobilization, and barge camp mobilization | - | - | 4-5 trips per month during drilling; 4-5 trips per season post-drilling | - | - |

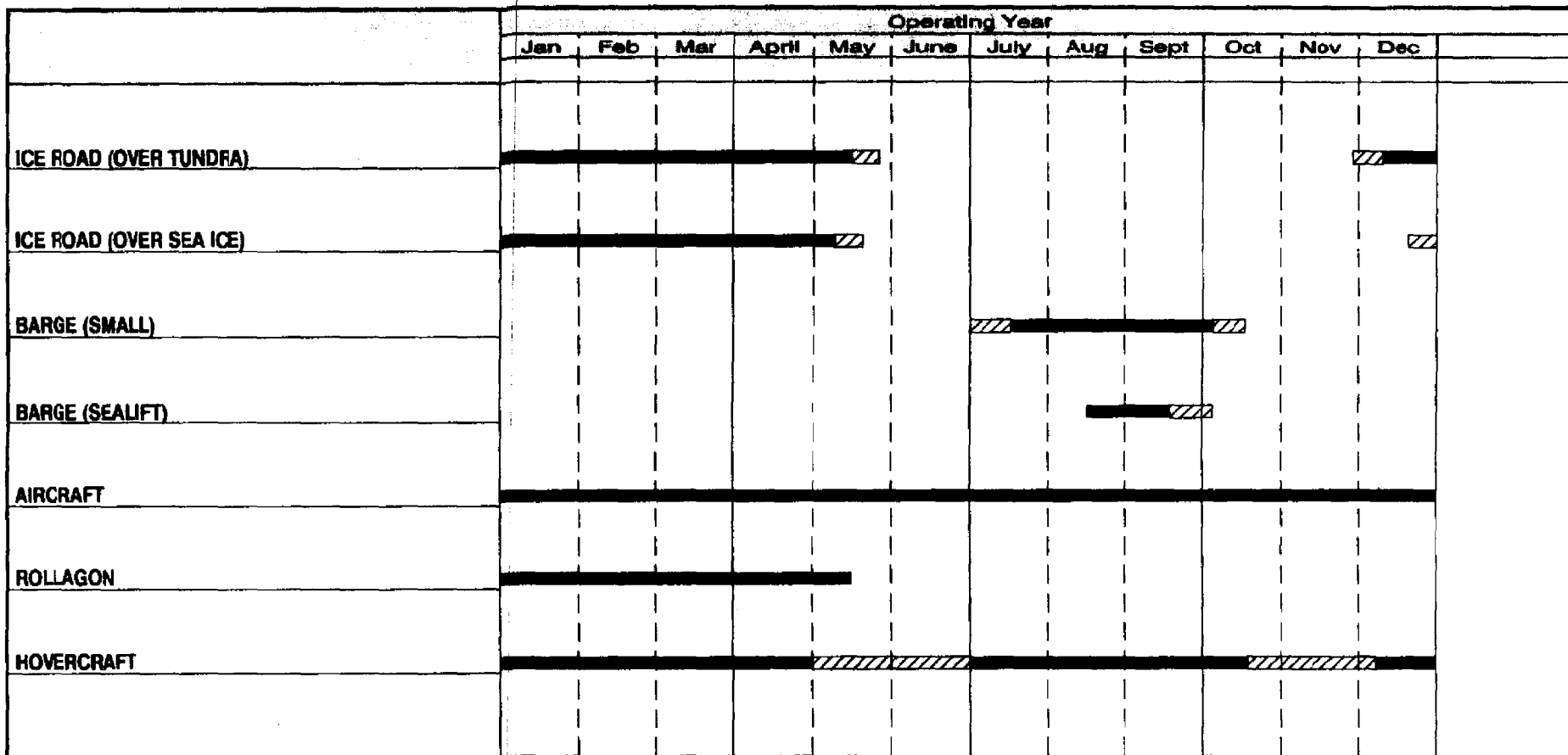

BP EXPLORATION (ALASKA) INC.

LIBERTY DEVELOPMENT
SEASONAL ACCESS LIMITATIONS

DATE:
September 1998

SCALE:
N/A

FIGURE:
4-1

5. GRAVEL ISLAND

A conventional gravel island will be constructed in Foggy Island Bay (Figure 1-2) to support project drilling, production operations, and infrastructure support functions. Island coordinates (NAD27) are:

Latitude 70° 16' 45.3431"N

Longitude 147° 33'29.0511"W

The island will be located in about 21 feet of water. Table 5-1 summarizes island design features.

5.1 ISLAND STRUCTURE

The island will be constructed of gravel hauled from the proposed Kadleroshilik River Mine Site; approximately 790,000 cubic yards of gravel will be required. The proposed island surface has approximate surface dimensions of 345 feet by 680 feet, and design bottom dimensions of 635 feet by 970 feet. The actual island footprint is likely to be larger than the design bottom dimensions. During the process of construction, gravel will be dropped through the water column to build the island structure up from the seafloor. In this process, not all gravel will fall precisely within the design footprint. To accommodate this construction uncertainty, BPXA has identified a construction footprint of about 835 feet by 1170 feet; this footprint includes an extra 100 feet around the perimeter of the design island bottom dimensions.

As shown on Figure 5-1, the island will have a working surface elevation of 15 feet above mean lower low water (MLLW), with a perimeter berm rising to 23 feet above MLLW. From the toe of the island to a bench located six feet above MLLW, the island will have 3:1 side slopes (Figures 5-2 and 5-3). A nearly level, 40 foot wide bench will be located at about six to seven feet above MLLW; side slopes above the bench will be 3:1. A scale model test of the island slope protection was conducted in February 1998 to confirm the final armor and cross section design.

Island slope protection is required to assure the integrity of the gravel island by protecting it from the erosive forces of waves, ice ride-up, and currents. In addition, by reducing the risk of erosion and associated introduction of sediment into the water column, slope protection offers a means to protect water quality.

The proposed Liberty slope protection design incorporates island side slopes and a bench protected with concrete mat slope armor, with a system of overlapping gravel filled bags at the top of the bench (Figure 5-4). The entire slope protection system is underlain by a durable and permeable filter fabric that will prevent leaching of sediment into the water column. The concrete mat provides structural protection, and the purpose of the bench and the gravel bags is to dissipate wave energy and limit ice ride-up potential. The bags also form a berm up to 8 feet high (elevation 23 feet above MLLW) around the island perimeter (except the dock). The position of

TABLE 5-1
DESIGN SUMMARY FOR LIBERTY DRILLING / PRODUCTION ISLAND

| ITEM | DESCRIPTION |
|--|---|
| Surface Dimensions (approximate) | 345 by 680 feet |
| Bottom Dimensions (approximate) | 635 by 970 feet |
| Height (working surface) | 15 feet above MLLW |
| Dock Size | 150 by 160 feet |
| Gravel Volume | 773,000 cubic yards |
| Concrete Blocks (4 foot by 4 foot blocks, plus variable size blocks) | 17,000 blocks (about 7,600 cubic yards of concrete) |
| 4 CY Gravel Bags (Polyester) | 4,200 bags (about 16,800 cubic yards of gravel) |

the bags does not allow frequent exposure to damaging waves and ice, and loss of gravel bag fabric debris is not expected. In the event that bags were damaged, effects would be negligible, because the bag fabric will be polyester, which is heavier (sinks in seawater) and is about four times stronger than the polyethylene bags used in construction of islands used for exploratory drilling in the 1980's. The concrete mat is composed of individual concrete blocks approximately 4 by 4 feet in size, linked together with stout chain and shackles (Figures 5-5 to 5-7). It will be secured to soil anchors placed in the island gravel fill. The bag system consists of 4-cubic yard polyester overlapped bags.

Maintenance procedures designed to prevent loss of bag material to the sea will be implemented. The bags will be inspected annually, before breakup. Any damaged bags would either be repaired, or removed and replaced.

A steel sheetpile dock on the south side of the island will allow transport of the drilling rig, processing equipment modules, and supplies onto the work surface.

In March 1998, BPXA conducted a geotechnical investigation at the island location. Five holes were drilled: one to an approximate 74 foot depth below mudline, and four to about 50 to 58 feet below mudline. Soils types were generally sands and gravels overlain by silts.

Before construction can begin, technical review and verification of the island structural design must be completed in accordance with the requirements of 30 CFR 250.902 - Platform Verification Program Requirements (see Section 10.2).

5.2 ISLAND SURFACE LAYOUT

The Liberty Island surface layout is shown in Figure 5-1. Key to this layout is a single row of wells along the center of the island with adjacent process facilities. This enables the wells to tie directly into the process and gas compression modules.

The facilities layout locates the gas compression module on the far north end, followed by the crude separation/treating module, which also contains the seawater treatment plant (STP) and power generator. The process control room and motor control centers (MCC) are located in a control module at the south end of the process module. The disposal well and gas injectors are located at the far north end of the well row adjacent to the gas compression module. The producing wells are adjacent to the oil separation with the waterflood wells adjacent to the STP at the most southerly end of the well row. The high pressure and low pressure flares are located off the Gas Compression Module on the north end.

The PLQ and utility module are located on the southeast side of the island providing for the maximum separation from the process equipment and gas injection/oil production wells. The warehouse/shop is located south of the control module.

The long axis of the island is orientated approximately north-northwest to south-southeast to accommodate the predominant east wind across the short axis of the island. This reduces the risk of a gas release or fire/smoke reaching the PLQ.

The east side of the island is dedicated to drilling. The grind and inject facility will be located near the disposal well on the far north end of the well row. Much of the available work

surface area on the island is available for storage of drilling consumables. This should be sufficient to safely drill and complete five wells before a re-supply is required. The surface layout plan (Figure 5-3) shows location of all fixed structures and the surface location of proposed and future wells.

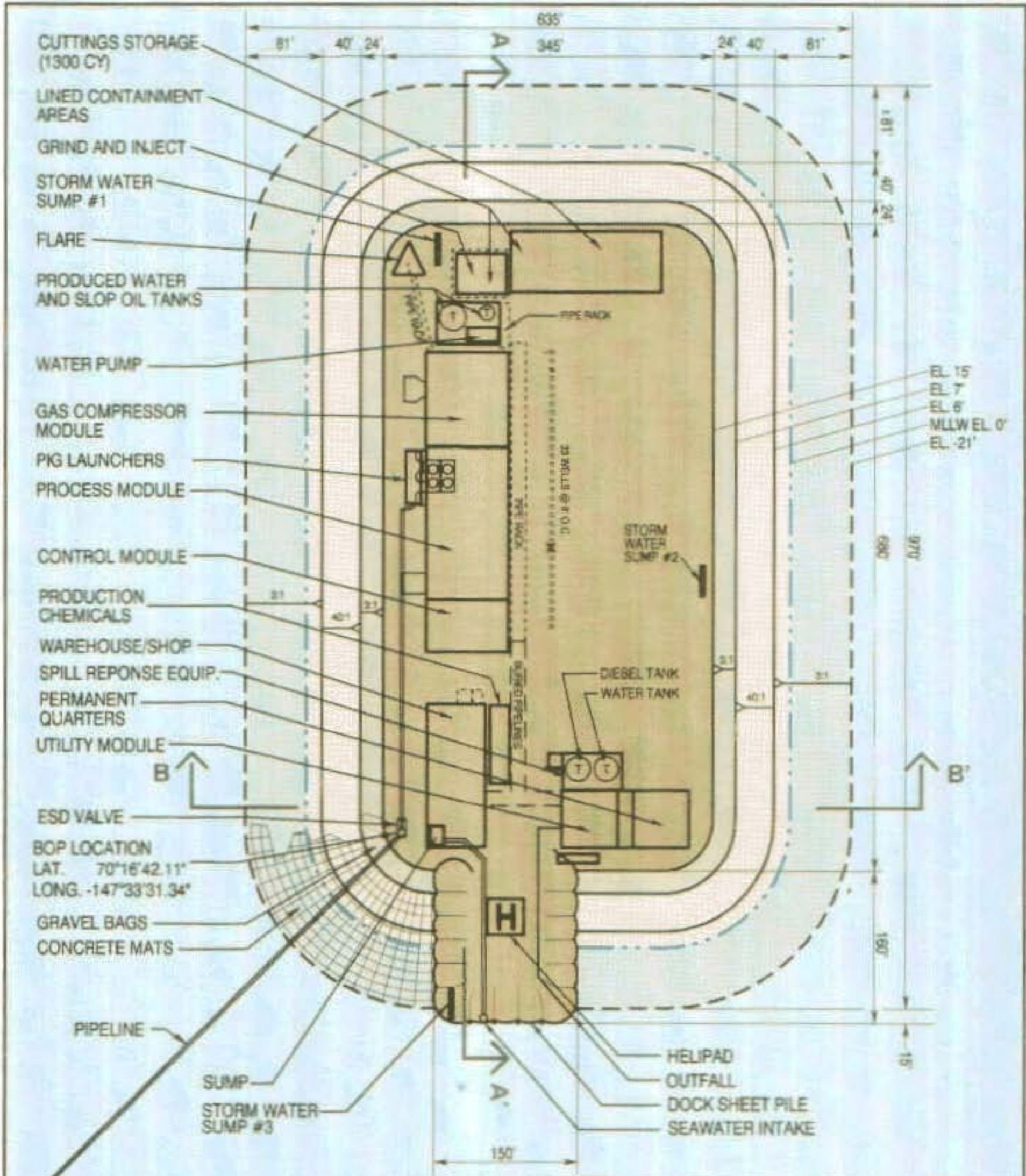

* ISLAND CENTER
 LAT. 70°16'45.3431"
 LONG. -147°33'29.0511"

ALL DIMENSIONS ARE APPROXIMATE

BP EXPLORATION (ALASKA) INC.
 LIBERTY DEVELOPMENT PROJECT
 ISLAND LAYOUT

| | | |
|--------------------------|------------------------|----------------|
| DATE: Rev. April 2000 | SCALE: NOT TO SCALE | FIGURE: 5-1 |
|--------------------------|------------------------|----------------|

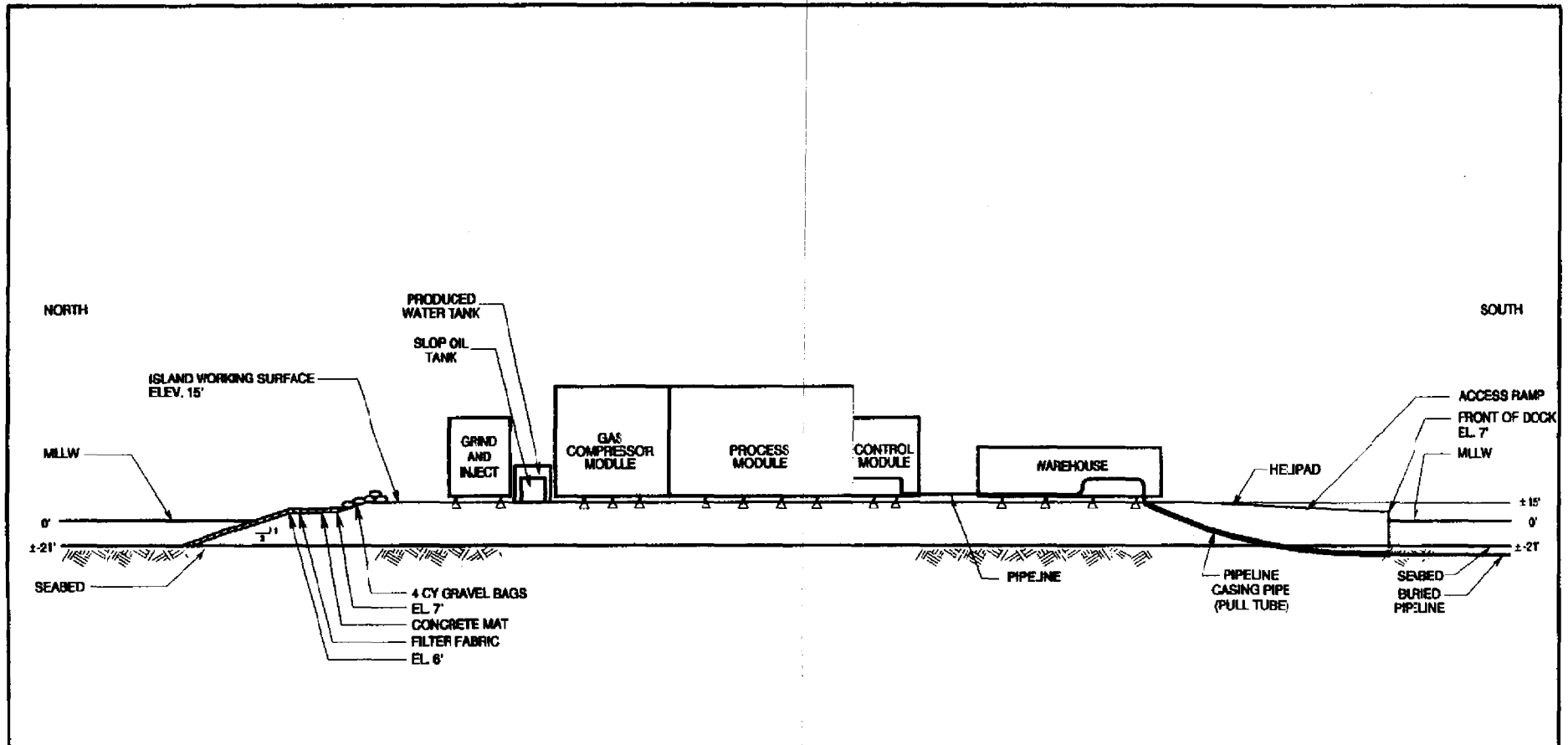

CROSS - SECTION A-A'

| | | |
|---|---------------|----------------|
| BP EXPLORATION (ALASKA) INC. | | |
| LIBERTY DEVELOPMENT PROJECT ISLAND CROSS SECTION A-A' | | |
| DATE: Rev. April 2000 | SCALE: N/A | FIGURE: 5-2 |

ALL DIMENSIONS ARE APPROXIMATE

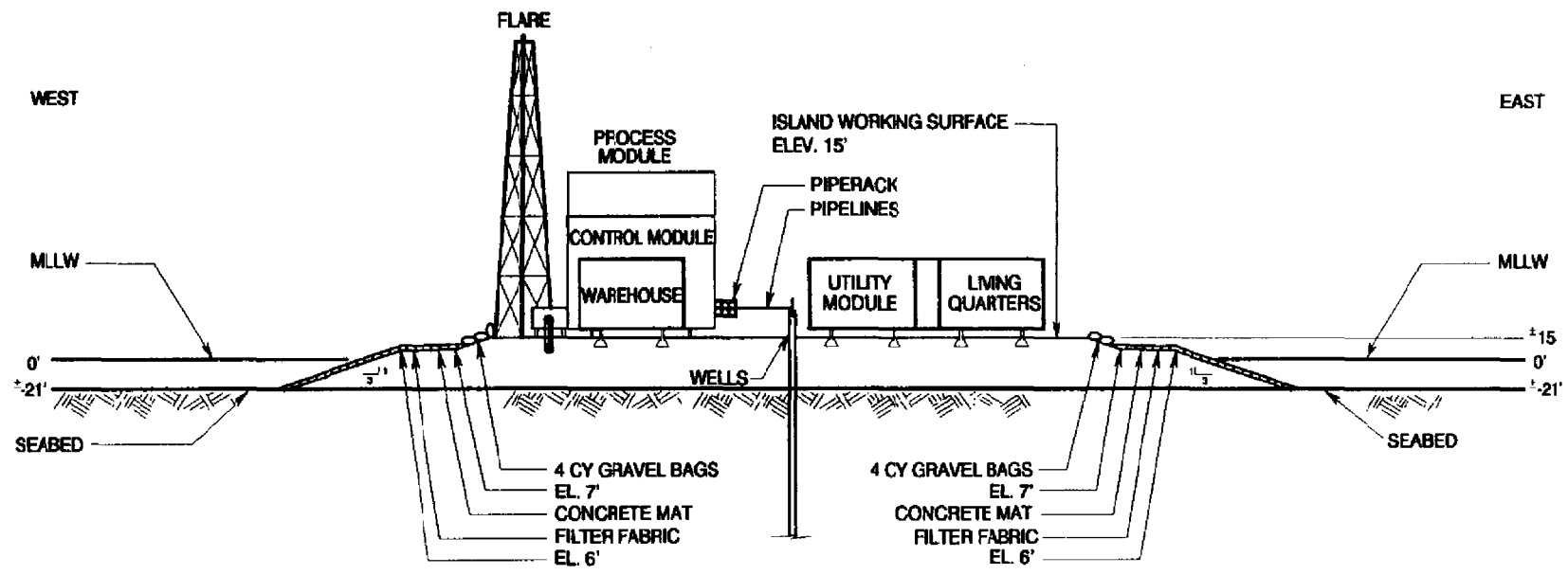

CROSS - SECTION B-B'

| | | |
|---|---------------|----------------|
| BP EXPLORATION (ALASKA) INC. | | |
| LIBERTY DEVELOPMENT PROJECT ISLAND CROSS SECTION B-B' | | |
| DATE: November 1998 | SCALE: N/A | FIGURE: 5-3 |

ALL DIMENSIONS ARE APPROXIMATE

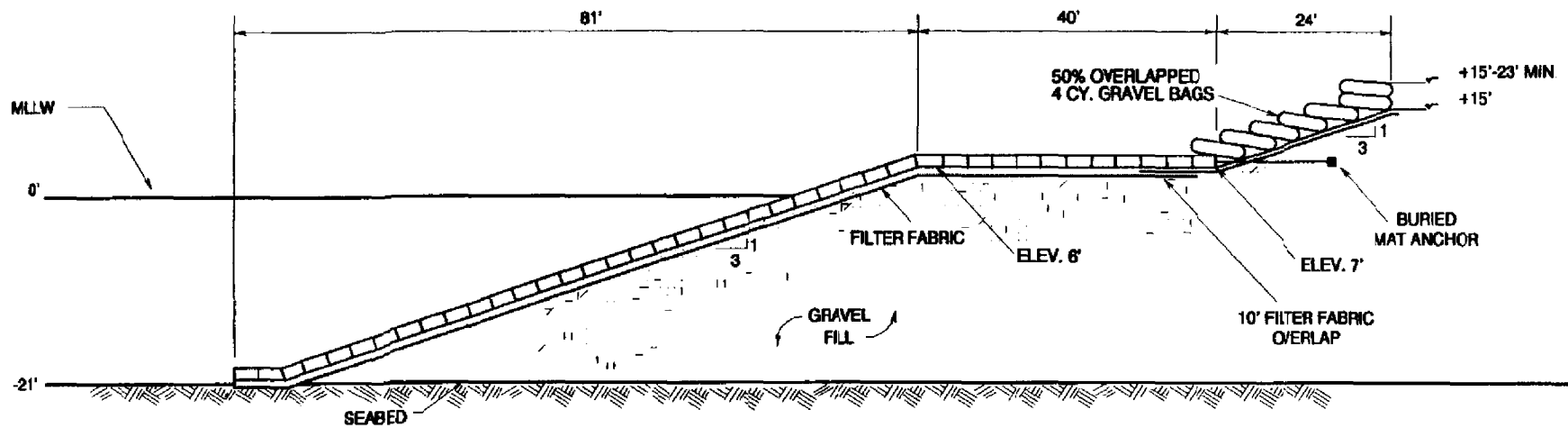

BP EXPLORATION (ALASKA) INC.

**LIBERTY DEVELOPMENT PROJECT
ISLAND SLOPE PROTECTION
CROSS SECTION AND DETAIL**

DATE:
November 1998

SCALE:
N/A

FIGURE:
5-4

ALL DIMENSIONS ARE APPROXIMATE

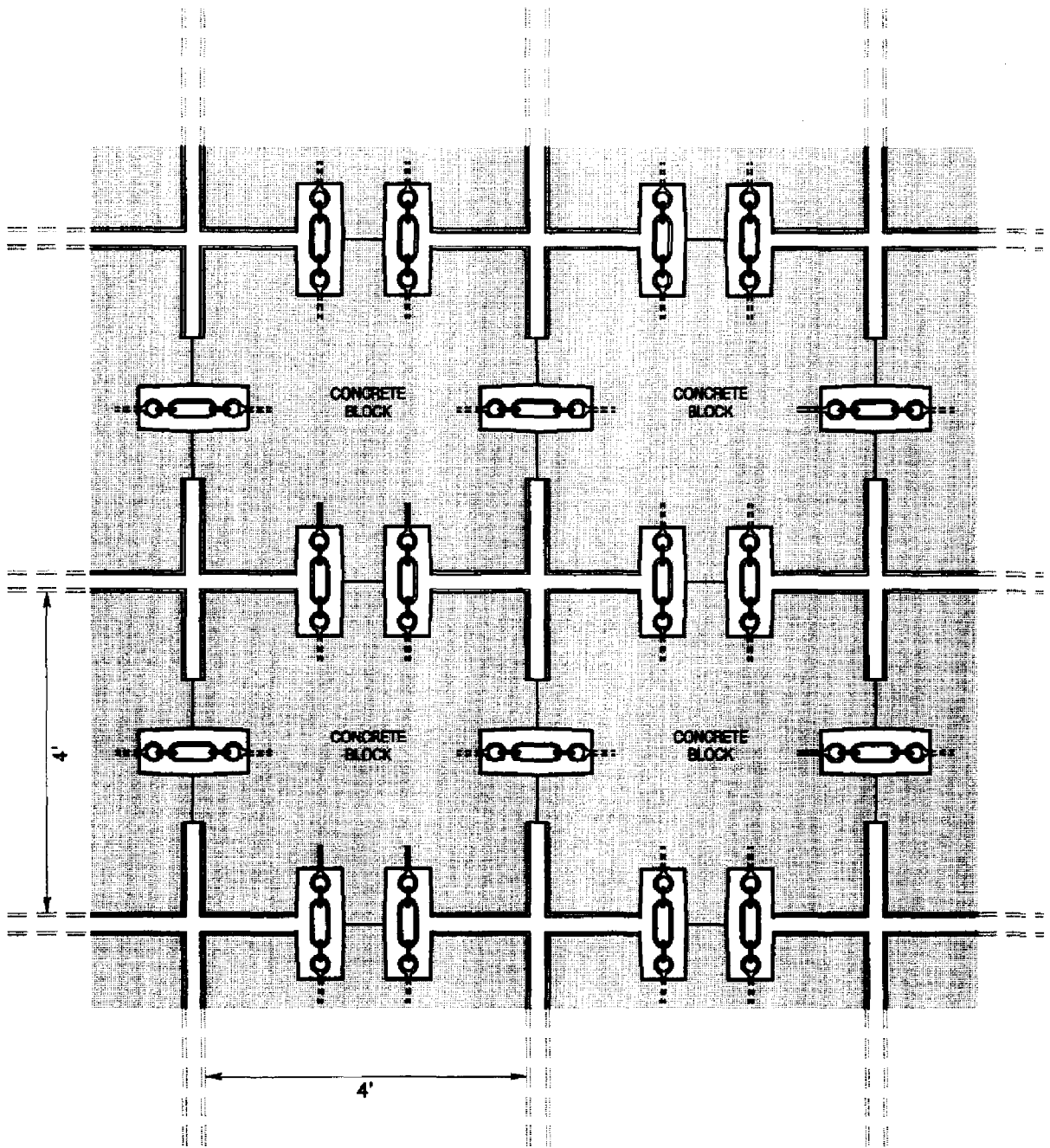

BP EXPLORATION (ALASKA) INC.

LIBERTY DEVELOPMENT PROJECT
 ISLAND SLOPE PROTECTION
 CONCRETE MAT
 LAYOUT

DATE:
November 1998

SCALE:
N/A

FIGURE:
5-5

45 DEGREES TOP
CHAMFER

9"

1" THICK INTEGRAL
CONCRETE BUMPERS
(TYPICAL)

48"

48"

BP EXPLORATION (ALASKA) INC.

**LIBERTY DEVELOPMENT PROJECT
ISLAND SLOPE PROTECTION
CONCRETE BLOCK**

DATE:
January 1998

SCALE:
N/A

FIGURE:
5-6

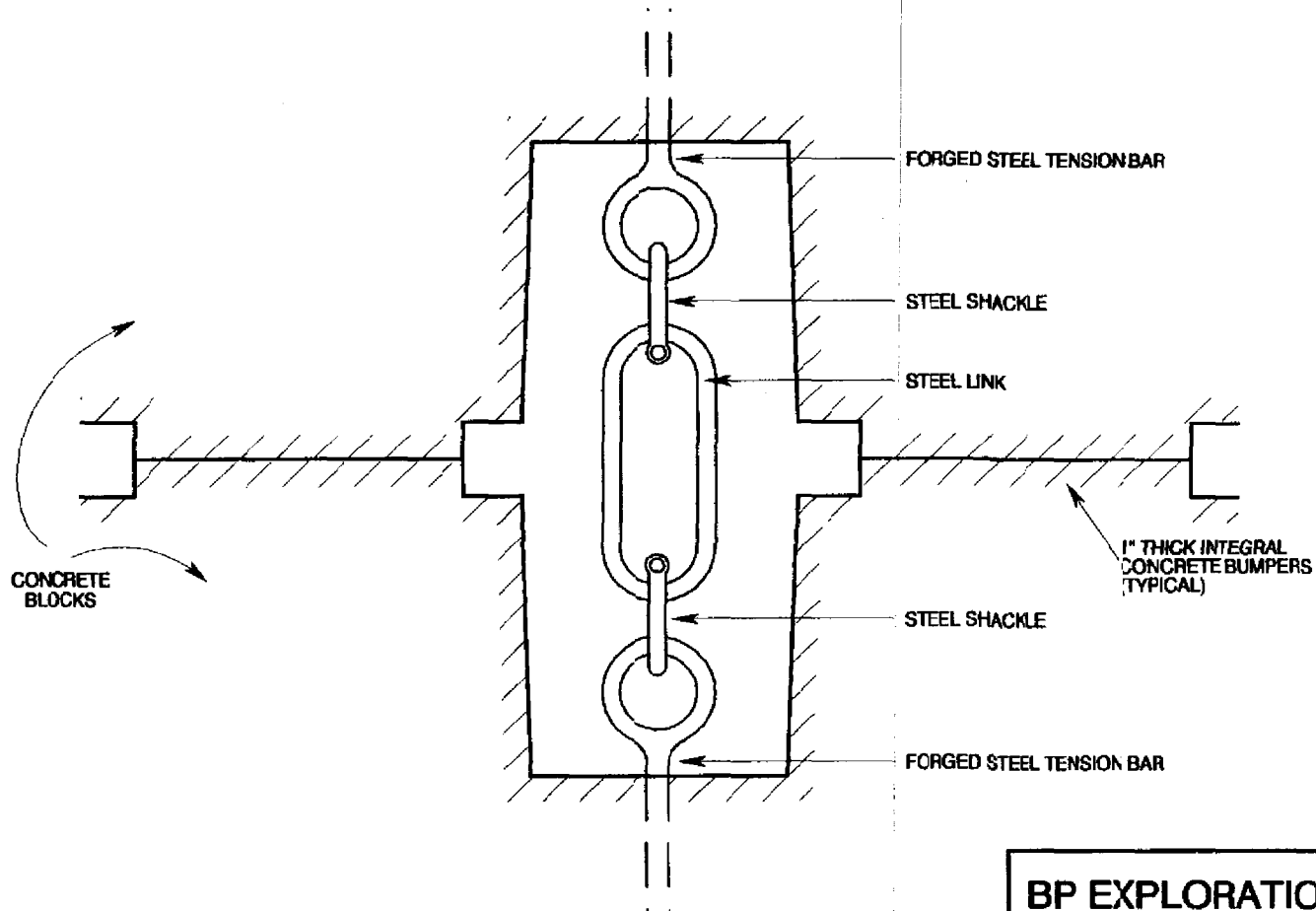

BP EXPLORATION (ALASKA) INC.

**LIBERTY DEVELOPMENT PROJECT
ISLAND SLOPE PROTECTION
CONCRETE MAT LINKAGE
DETAIL**

DATE:
January 1998

SCALE:
N/A

FIGURE:
5-7

6. FACILITIES

6.1 DESIGN BASIS

Design capacities and specifications for Liberty facilities are listed in Table 6-1. Liberty oil is a medium gravity crude with an API gravity of 25° (tested range 22° to 28°), a gas to oil ratio of approximately 800 to 900 scf/stb, and a carbon dioxide content of 12 percent in the reservoir fluid (18 percent in the separated gas phase). The hydrogen sulfide content of the gas phase is approximately 8 parts per million (ppm).

Process facilities will be designed to produce 65,000 barrels of oil per day (BOPD) of sales quality crude oil. (See Section 6.5 for discussion of an option that, if implemented, could increase plant capacity up to 75,000 BOPD.) Waterflood and re-injection of produced gas will be used from start-up to maintain reservoir pressure and improve recovery. Produced gas will be dehydrated, compressed and used for fuel gas, lift gas, and the remainder reinjected. Produced water and seawater will be commingled for waterflood injection. The economic field life is currently estimated to be approximately 15 years. Accordingly, the facilities/pipeline have a minimum operational economic life of 20 years. Note that this operational economic life is not the same as design life - project design criteria used for the pipeline, island, and facilities considered extreme environmental events (e.g. wave, ice, storm, seismic conditions, etc.).

The design reservoir temperature is 225°F and the pressure is 5,200 psig. The surface flowing temperature will vary over time depending on gas to oil ratio, watercut, and oil rate, but is expected to be between 145°F and 210°F. Flowing wellhead pressure will vary from well to well over the life of the project with an expected range of 350 - 3,000 psig depending on watercut and gas-to-oil ratio. Wellhead shut-in pressure will be less than 5,000 psig.

Table 6-1 lists TAPS specifications sales oil delivery at Pump Station 1. Treated crude oil from the Liberty facility will be pumped through the Liberty pipeline to the tie-in point with the Badami pipeline. The commingled stream will then be transported to TAPS via the Badami and Endicott pipelines.

6.2 OIL AND GAS PROCESS SYSTEM

A simplified process flow diagram is shown in Figure 6-1.

6.2.1 Design Philosophy

The facility design philosophy is a single train with limited sparing. [Limited sparing means that expensive major process equipment (with high reliability) will not have an installed spare. If the equipment shuts down, the process will be shutdown and production will be stopped until the plant can be restarted. Limited sparing does not apply to safety related equipment.] If

**TABLE 6-1
LIBERTY DESIGN CAPACITIES AND SPECIFICATIONS**

| DESIGN FACTOR | ITEM | CAPACITY |
|--------------------------------|---------------------------------------|--|
| Plant Capacities | Sales Oil | 65,000 barrels of oil per day |
| | Produced Gas | 120 MMscfd maximum future |
| | Gas Lift Gas (future) | 30 MMscfd |
| | Seawater Treatment | 75,000 barrels of water per day |
| | Produced Water Handling | 100,000 barrels of water per day |
| | Water Injection | 140,000 barrels of water per day |
| Single Well Capacities | Maximum Oil Flow | 15,000 barrels of oil per day |
| | Associated Gas At Maximum Oil Flow | 13 MMscfd |
| | Maximum Produced Gas | 30 MMscfd |
| | Associated Oil At Maximum Gas Flow | 2,000 barrels of oil per day |
| Product Specifications | Sales Oil | TVP 14.2 psia maximum, 1415 psia maximum operating pressure 14.0 psia operating, 0.35 percent BS&W |
| Product Delivery Conditions | Sales Oil at PS-1 | 105°F to 142°F, 85 psig minimum |
| | Gas Injection | 5,000 psig at wellhead, 240°F maximum at wellhead |
| | Gas Lift Gas (future) | 2,500 psig minimum |
| | Produced Water | 400 to 500 ppm oil in water |
| | Seawater | 98 percent removal of all solids 5 microns and greater 20 ppb maximum dissolved oxygen |
| | Water Injection | 2,700 psig and 250°F maximum at wellhead |

the main single train gas compressor (third, fourth and fifth stages) is inoperable, production will be shut down. The operating philosophy for handling equipment downtime and process upsets is to 1) first shut-in, 2) depressure when required, and then 3) solve the problem. No storage capacity is available for off-specification oil (non-sales quality). The plant could be operated at reduced capacity with emergency generators.

Due to the crude oil carbon dioxide and high chloride content, duplex corrosion resistant alloy piping will be used for well production flowlines. Stainless steel piping will be used for all wet gas services due to the high carbon dioxide content. Production and wet gas separators will be internally coated for corrosion protection.

To minimize air emissions, facility design and selection considerations included best available control technology (BACT), new source performance standards (NSPS), and assurance monitoring. Gas turbines will be equipped with dry, low nitrogen oxide (NO_x) combustion systems to minimize NO_x exhaust emissions as needed. BACT requirements also apply to the utility equipment.

In accordance with BP corporate policy, process design incorporated measures to reduce the emissions of "greenhouse gasses", notably carbon dioxide. These measures include the selection of efficient turbine drivers, minimizing flaring during operation upsets, process heat recovery, seawater deaeration using vacuum stripping rather than fuel gas stripping, and fuel gas pretreatment to reduce carbon dioxide content.

6.2.2 Process Summary

Oil Separation

The wellhead crude oil mixture (oil, water, and gas) will flow from the producing wells to the inlet separator. The inlet separator will operate at approximately 230 psig. Gas and water will be separated from the oil in this vessel. Gas will exit overhead, be cooled and then flow to the suction of the third stage compressor. Produced water will be drained off and routed to the produced water tank for degassing, solids settling and oil skimming. The produced water will then be pumped and blended with treated seawater for waterflood. The inlet separator has sufficient volume to handle swings in the flow (slugs) from the producing wells.

Oil from the inlet separator will be heated to approximately 170°F prior to flowing into the low pressure (LP) separator. A plate and frame exchanger will be used for heating. The heating medium will be supplied by the plant process heat recovery system.

As the warm oil enters the LP separator the pressure is reduced from 230 psig to 60 psig and additional dissolved gas that is in solution with the oil is liberated (a process referred to as flashing). Water will be routed to the produced water tank. From the LP separator the crude will be flashed to 10 psig in the gas boot to achieve the vapor pressure specification. Gas will be separated and routed to the first stage compressor. The gas boot will be operated as a two phase separator.

Sales Oil Conditioning

Crude oil from the gas boot will require additional treatment to meet the TAPS specifications. Crude will be pumped to the oil dehydrator, where an electrostatic grid will reduce the water content. Crude from the oil dehydrator will be cooled to approximately 135°F, pumped and metered, and continuously analyzed to verify it meets specifications. The conditioned crude will be routed to the Sales Oil Pipeline for shipment to TAPS via the Badami/Endicott Pipelines.

Test Separation

A two-phase test separator will be used for individual well testing and clean-up. Individual wells will be routed to the test separator as desired during operations. The wellhead stream will be separated into a gas and liquid stream. The liquid stream will be metered and analyzed for water cut, and the gas stream will also be metered. After testing and metering the outlet oil/water and gas streams will be re-combined and routed to the inlet separator. As needed for individual well clean-up, the re-combined well liquid stream can be routed to the slops tank or LP separator.

Gas Compression and Treating

The two stages of flash gas compression will be from atmospheric pressure to 60 psig and from 60 to 230 psig. The hydrocarbon vapor collected from the produced water and slop oil tanks will also be compressed in this system. The gas from the discharge of the second stage will flow to the suction of the third stage compressor. The third stage compressor will increase the gas pressure to approximately 860 psig. Following the third stage of compression the combined wet gas stream will be dehydrated in a triethylene glycol contactor where water will be removed to a -50°F water dew point. Following dehydration the gas will be routed to the fourth stage compressor where the pressure of the gas stream will be increased to approximately 2370 psig. The fifth and final stage of compression will raise the gas pressure to approximately 4750 psig. Liquids condensed at the suction of the fourth stage compressor will be collected and returned to the production separator where they will be combined with the oil stream. The first and second stage compressors will be electrical driven compressors. The third, fourth and fifth stage compressors will be in tandem and driven by a single 32,000 hp gas turbine.

Gas Lift

A portion of the fifth stage discharge will split to supply gas lift (future) as required. The gas lift gas will be dropped to a pressure of approximately 2,500 psig.

Gas Injection

After the produced gas is dehydrated and natural gas liquids collected, the remaining net gas (minus the fuel gas required) from the discharge of the fifth stage compressor will be reinjected back into the producing formation.

Process Heat Recovery System

Process heat for crude heating, fuel gas heating, and seawater heating will be provided by a closed loop re-circulating heat medium (water/glycol) system. The normal heat source for the heat medium will be process heat recovery from the third and fourth stage (gas) discharge exchangers. An environmental loop heater, fired by fuel gas, will be used to provide heat to plenums and enclosures as well as standby heat for start-up.

Produced Water Treatment

Produced water separated from the crude oil production will be treated and reused in the waterflood program to maintain reservoir pressure. The treatment system will include a produced water surge/skim tank which will de-gas and remove any remaining free oil from the produced water prior to injection. Produced water and treated seawater will be commingled and pumped to a pressure of 2700 psig for reinjection into the formation for pressure maintenance. Hydrocarbon gases released from the produced water in the produced water tank will be recovered by the first stage compressor.

6.3 SEAWATER INTAKE AND WATERFLOOD FACILITIES

The Liberty depletion plan is to maintain reservoir pressure and enhance reservoir recovery with a combination of waterflood and produced gas re-injection. In addition to produced water, approximately 75,000 barrels of water per day of treated seawater will be needed for the Liberty waterflood to maintain reservoir pressure during early production. The Liberty seawater treatment plant (STP) will supply treated water for this use.

The seawater intake system (Figure 6-2) includes measures to minimize the potential for entraining fish in the intake stream. The intake structure consists of an 8-foot diameter pipe installed vertically at the edge of the Liberty island dock (perpendicular to the seafloor), with an internal concrete plug at the base. Approximately 19 feet down from the intake lid at the dock surface (approximately 7.5 feet down from the mean low water level), an 8-foot by 5-foot 8-inch rectangular opening in the side of the pipe allows the inflow of seawater. A collar around the opening is welded to the sheet pile (approximately flush with the dock face).

Just inside the opening is a series of vertical pipes that continuously recycle warm seawater from the STP to prevent the intake from freezing. The recirculation system is designed to raise temperature in the intake 0.5°F over ambient to keep frazil ice from forming on the screens. The system is designed for all recirculating seawater to be drawn back into the seawater sump. The re-circulation pipes will also act as bars to keep out large fish, other animals, and debris.

Downstream of the pipes are two parallel screens located in a vertical position. The dual screen system allows for one screen to be in place when the other is removed for cleaning or repair. For cleaning, the screen closest to the intake pipe will be removed, cleaned, and replaced then the outer screen will be cleaned in a similar manner. The facility operator will be able to remove the screens from the island surface. The intake screen slot size is 0.25 in x 1.0 in (similar

to the Endicott STP intake). Downstream of the screens is a 36-inch HDPE pipe, installed horizontally to intersect the intake and carry seawater, via gravity flow, into a sump, from which seawater is drawn when needed for project operations.

There is a range of operating velocities for the seawater intake. At maximum, the velocity at the bars is 0.46 feet per second (fps), at the first screen it is 0.29 fps, and at the second screen it is 0.33 fps, all below the design criterion maximum of 0.5 fps. This is based on all three pumps in the seawater sump (firewater pump seawater pump and utility water pump) operating at the same time, with maximum flow on the intake. Normal operation would consist of the seawater pump and the utility water pump. Typically, only once a week for a few hours, the firewater pump would be activated to test the firewater system, creating maximum flow on the system, resulting in the maximum velocities noted above. The seawater pump in the seawater inlet facility feeds the STP.

As final design proceeds, BPXA will optimize the intake design with the objective of reducing potential impacts to fish. This design optimization process will address overall intake configuration, including mesh screen sizes, bar placement, and intake velocities.

The STP feed (raw seawater) will be passed through a strainer to remove coarse solids greater than approximately 80 microns. Then hydrocyclones will be used to remove finer solids down to approximately 10 microns prior to deaeration. The reject stream from the hydrocyclones will be routed to the seawater outfall for discharge under an National Pollutant Discharge Elimination System (NPDES) permit.

Downstream of the hydrocyclones, the seawater will be routed to a heat exchanger and then to the deaerator column where oxygen will be removed by vacuum deaeration. Oxygen scavenger will be injected in the column to remove trace amounts of remaining oxygen to approximately 20 parts per billion (ppb). Corrosion inhibitor and scale inhibitor will be added to the treated water stream. Treated seawater and produced water will be combined downstream of their respective booster pumps. Injection pumps will be used to raise the treated water pressure to 2,700 psig for injection into the reservoir.

Biocide, antifoam, oxygen scavenger, corrosion inhibitor, and scale inhibitor will be used in the seawater treatment system.

6.4 PROCESS SAFETY SYSTEMS

The process safety systems for Liberty are designed to automatically return the wells and the processing facilities to a safe state following an emergency plant upset. The system will be designed to automatically activate increasing levels of isolation and depressurization as required. The system will initiate four different types of control action depending on the severity of the event. The four types of shutdowns are a Unit Shutdown (USD), Operations Shutdown (OSD), Emergency Shutdown (ESD) and Blowdown Emergency Shutdown. (BESD). They are described as follows:

- USD - initiated, as required for the protection of an individual piece of equipment or area of the facility.

- OSD - initiated through alarm criticality, which requires only the shutdown of the hydraulic wing valve to stop incoming oil, or at operator discretion.
- ESD - initiated through alarm criticality, fire detected in the Process Module, high gas concentration (40 percent lower explosive limit (LEL)) detection. An ESD requires the entire facility to be shutdown and isolated but remain pressured, or at operator depressurized.
- BESD - initiated through alarm criticality, which requires the entire facility to be shutdown, isolated and depressured.

The primary shutdown device is the actuated wellhead surface safety system, which will stop incoming fluids. All production wells will also be equipped with actuated surface and subsurface safety valves which will be activated in the case of a depressurized shutdown.

The Liberty process facilities will be equipped with a shutdown valve (SDV) to isolate the facilities from the pipelines in the case of an emergency.

Instruments for continuously monitoring for the presence of flammable gas and fire will be installed in all areas where there is risk of leakage which could lead to a dangerous escalation. Smoke detection will be installed in the control room/control module as necessary. Fire detection systems will provide alarm only at key locations. Protective action will be by automatic or remote or local manual initiation.

Manual alarm indications will be located at strategic points throughout the facility and a fire protection panel will be programmed in the central computer system, provided with zone indication of detector points. The fire and gas system will be provided with a secure electrical power supply.

When activated, the fire alarm detection system will shutdown and blowdown the facility via the BESD. If an actual fire is identified, the fire suppression system will be activated. If the gas detection system detects a 20 percent LEL gas concentration, the emergency ventilation fans will start, increasing air changes. If the gas concentration continues to rise to 40 percent LEL, BESD will be activated, causing the facility to shutdown and be isolated, and all production wells to be shut in and the facility de-pressured. To ensure proper performance of a deluge sprinkler, the module temperature will be maintained at minimum 40°F. This will be achieved by shutdown of the emergency fans when the module temperature drops below 40 degrees.

The process facility will have a high pressure and a low pressure flare to provide the safe and controlled release of safety emergency vents and pressure relief valve discharges during equipment failures. All pressure vessels will be protected with pressure relief valves and independent pressure and level shutdown instrumentation. The flare and relief system will be designed in accordance with API RP 520/521.

All plant shut down and safety systems will be designed in accordance with API Recommended Practices 14C, Design, Installation and Testing of Surface Safety Systems for Offshore Production Platforms. To assure safe operation of the facilities, complete piping and instrument diagrams and Safe Charts will be developed.

6.5 INCREASED PRODUCTION OPTION

BPXA has evaluated methods by which the planned plant capacity of 65,000 barrels of oil per day (BPOD) could be safely increased with minor modifications to allow peak production of 75,000 BPOD. This evaluation (“debottlenecking”) is a normal oil field operations practice, typically occurring during production. A Liberty debottlenecking study was conducted early to identify means by which plant operating efficiency could be increased. While not proposed at this time, if this option were implemented it would increase plant efficiency to allow flexibility to increase production over short periods to make up for production losses relating to maintenance shutdowns, equipment reliability, or pipeline slowdowns. Before BPXA would decide to implement this option, additional studies would need to be conducted to completely evaluate the effects operating with increased plant capacity might have on recovery of reserves and on the life of the field. If this option were implemented, it would result in occasional increases in peak production rates over current proposed rates, as follows:

- Sales Oil - 75,000 barrels of oil per day
- Produced Gas - 140 MMscfd maximum future
- Seawater Treatment - 84,000 barrels of water per day
- Produced Water Handling - 115,000 barrels of water per day
- Water Injection - 161,000 barrels of water per day

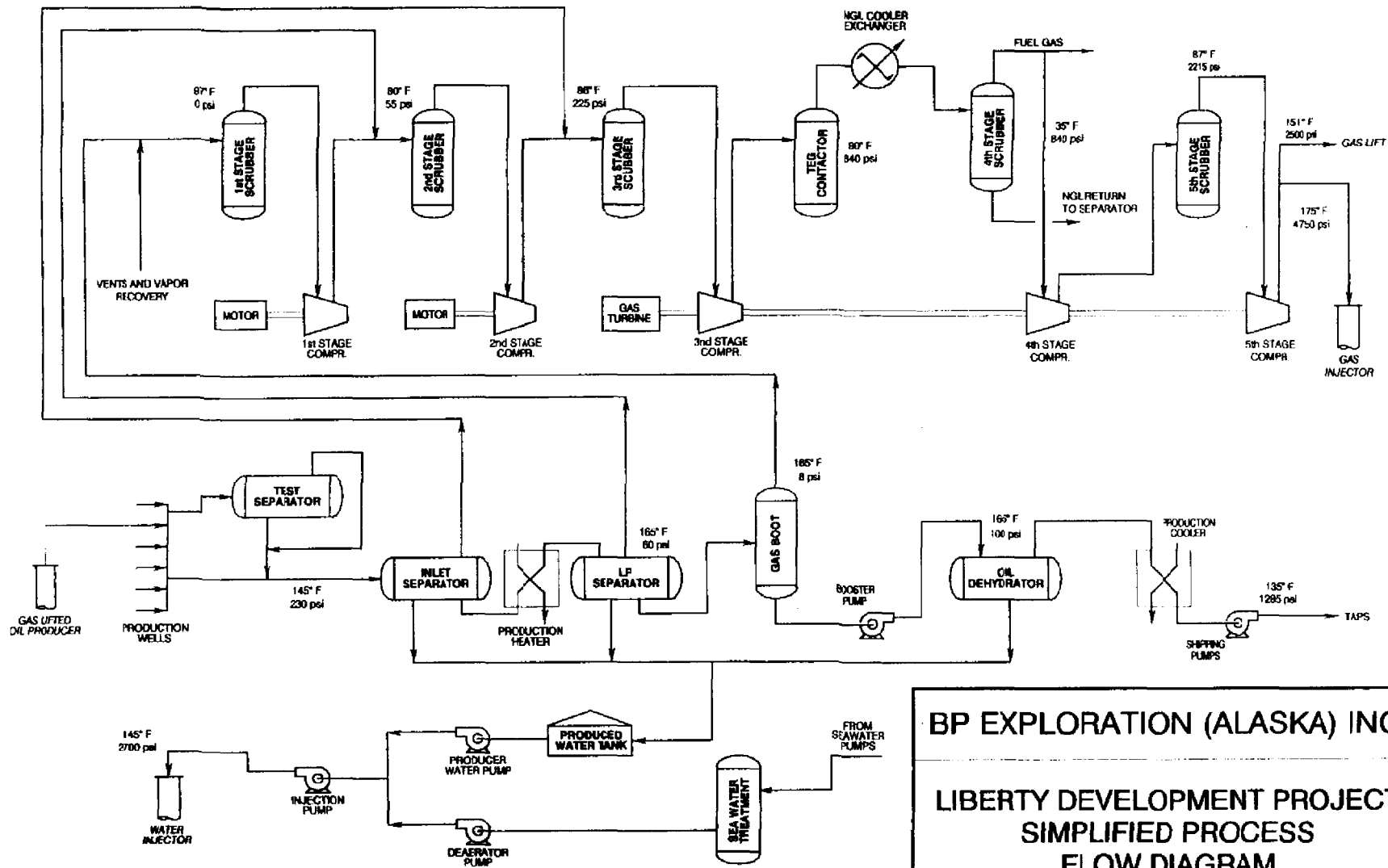

BP EXPLORATION (ALASKA) INC.

**LIBERTY DEVELOPMENT PROJECT
SIMPLIFIED PROCESS
FLOW DIAGRAM**

| | | |
|--------------------------|---------------|----------------|
| DATE: Rev. April 2000 | SCALE: N/A | FIGURE: 6-1 |
|--------------------------|---------------|----------------|

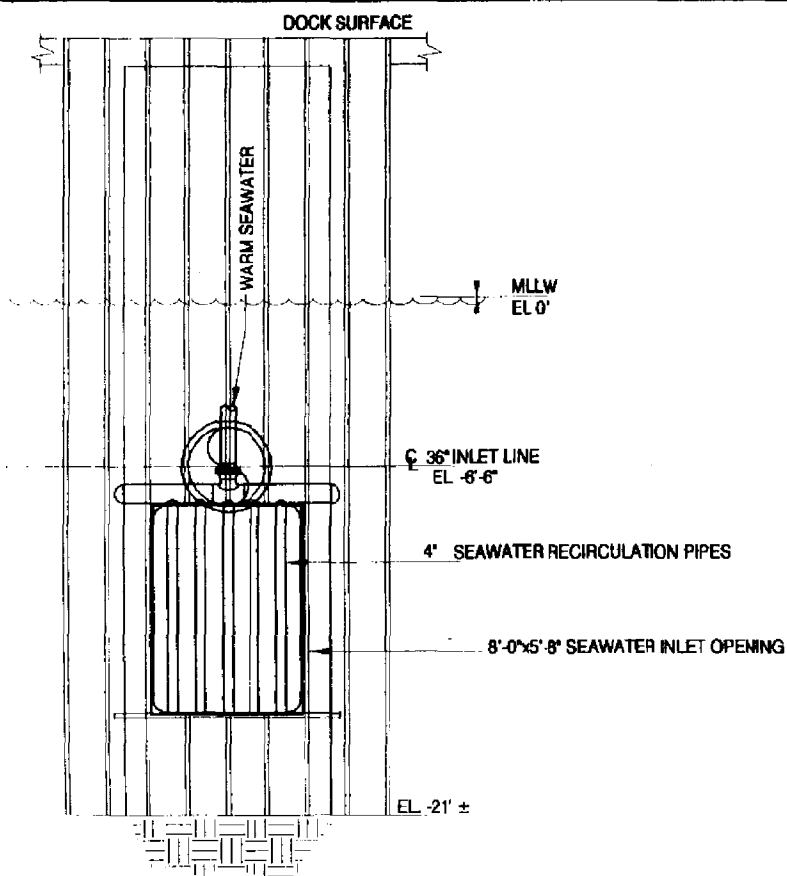

FRONT ELEVATION

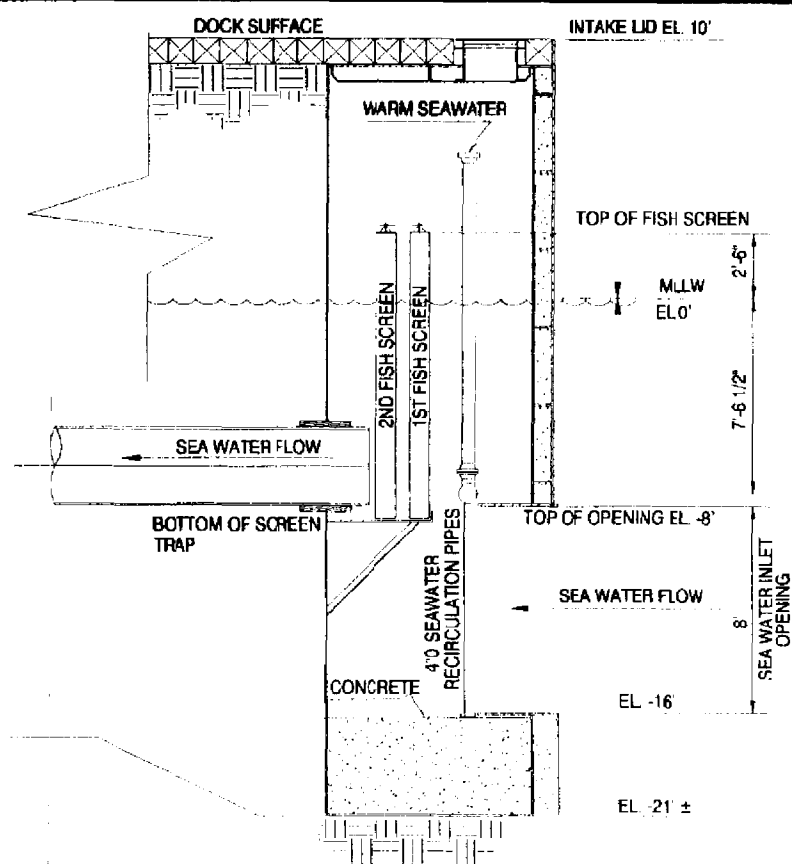

SIDE ELEVATION

BP EXPLORATION (ALASKA) INC.

LIBERTY DEVELOPMENT PROJECT
SEAWATER INTAKE DETAIL

DATE:
September 1998

SCALE:
Not to Scale

FIGURE:
6-2

ALL DIMENSIONS ARE APPROXIMATE

7. DRILLING

7.1 INTRODUCTION

Table 7-1 summarizes the planned development drilling program.

TABLE 7-1
LIBERTY DEVELOPMENT DRILLING PROGRAM

| WELL TYPE | NUMBER |
|-----------------|--------|
| Gas Injectors | 2* |
| Water Injectors | 6 |
| Oil Producers | 14 |
| Disposal | 1** |

*1 pre-produced

** two wells will be permitted; one will be drilled, with the other to be drilled in the event the first disposal well fails

A drill rig and consumables will be mobilized to the site by barge in the summer of Year 2 from the Prudhoe Bay Area. Drilling is scheduled to begin in January Year 3 using electrical power supplied by emergency diesel generators. Drilling will continue until August of Year 3, when the module sealift arrives on the island. After Liberty facilities are commissioned (approximately November Year 3), drilling will resume, and will continue until approximately February Year 5, when all the wells will be drilled. After field startup, the drilling rig will be supplied electrical power from the main gas turbine engines.

7.2 LIBERTY ISLAND AND DRILLING FOOTPRINT

7.2.1 Island Layout

The island layout, as shown in Figure 5-1, allows both drilling and facilities sufficient room to effectively operate. The drilling footprint covers virtually all the eastern half of the island.

The single row of wells offers the most flexibility for utilization of most of the existing North Slope rig inventory, and is located down the center of the island. The water injector wells

will be drilled from the island southern slots so that greater departure is obtained between the living quarters at the south end of the island and the producer/gas injector wells.

7.2.2 Well Spacing

In order to maximize the number of slots available, the well spacing at Liberty will be nine feet. This will allow for the 23 development and service wells programmed for initial development plus additional slots for infill drilling, exploration/appraisal wells, and possible future satellite development. The total number of slots available will be rig-dependent, but a range of 36 to 40 wells is achievable.

7.2.3 Drilling Footprint

The total drilling footprint includes:

- the area of the rig(s) moving from one end of the row of slots to the other
- pipe loading/access space at each end
- area for grind and inject facility, bulk plant, service units, plant support
- area for storage of well consumables

Rig/Slots

The rig/slot area was considered for a variety of North Slope rigs capable of working on, or being modified to, nine-foot centers. Two types of rig are available: wheeled, modular rigs and skidable rigs. The wheeled modular rigs offer maximum flexibility in moving between pads and between slots due to their self-propulsion. The skidable rigs require dismantling and reassembling between pads and even between different rows on the same pad. Because this could be a 14 day operation and is costly, their use on North Slope operations has declined. However, Liberty is a single pad development and, once assembled, the rig can skid along the single row of wells in a matter of hours. The skidding capability comes from having a pair of I-beams either side of the slot/cellar along which the substructure skids using Hillman rollers plus a second pair of I-beams under the service buildings/pipeshed to allow skidding in parallel to the substructure.

The wheeled rigs require more area normal to the line of wells to enable them to back off from wells and move along the line. The skidable rigs require less area normal to the line of wells but more space laterally to the line of wells given their shape.

Service Units

Advantage has been taken of available space on the facilities side of the island to locate the grind and inject facility. The cement bulk plant is likely to be located in the southeast corner of the island close to the utility module. The other service units are mobile and will be located where possible. There is an opportunity to mount service units on the I-beams should a skidable rig be selected.

Well Consumables

Consumables will be stored on the open gravel areas within the footprint. Detailed planning of logistics will be vital for minimizing double-handling of materials for rig moves.

Drilling/Facilities Interface

High-line power and utilities will be provided to the rig from gas turbine generators (after facilities startup), including 13.8kV power, fuel gas (for rig heaters/boilers), seawater, mud transfer lines, cuttings disposal lines, and firewater. These will be included in a utility piperack which will run the length of the line of wells. The flowlines will be designed so that either rig type can access a Liberty well without the need to dismantle flowlines. The I-beams for skidable rigs will be shimmed off the gravel to allow passage of the flowline underneath.

7.3 DRILLING UNIT

The Liberty drill rig has not yet been selected. The design of the drilling footprint and rig/facilities interface has been developed with the goal of not compromising the ability to use either modular wheeled or skidable rig types of various dimensions. This is also valid in that there will likely be more than one rig working at Liberty over the life of the field. Regardless of rig selection, a full inventory of major drilling equipment will be provided.

Safety features will include a surface hole diverter system; a main blowout preventer (BOP) stack consisting of 2,000 psi annular preventer and 5,000 psi ram preventers (x3), adaptor spool, choke and kill lines, choke manifold, BOP control system and remote panels; degasser; drillstring BOP devices. Fire/first aid items will include fire extinguishers, fire hoses, first aid kits, stretchers, breathing packs etc.

Initial rig mobilization will take place by barge in summer Year 2. All the rigs considered for the development drilling program can be mobilized/demobilized by barge. The skidable rigs can also be moved by floating ice road whereas certain wheeled modular rigs cannot.

7.4 WELL DESIGN

7.4.1 Casing Design

The base casing design for oil producers, gas and water injectors is the same, i.e. they have the same casing setting depths. However, different casing sizes apply for each well type as dictated by the completion tubing requirements. The base design is as follows:

- conductor: all wells will have 20 inch conductor driven to 160 feet TVD SS or 200 feet TVD BRT. The conductors will likely be driven with impact hammers consecutively over a period of one to two weeks.
- surface casing: will be set in the SV5 shales at approximately 4700 feet TVD which gives adequate fracture gradient strength to drill intermediate hole either to top reservoir to set casing or beyond the reservoir for "longstring" wells i.e. where intermediate hole/casing is set through the reservoir.

- intermediate/production casing: will be set in the top reservoir to case-off the HRZ Shale. It is anticipated that the oil producers, gas injectors and some water injectors will set an intermediate casing string. Longstring wells will be utilized for certain water injector wells.
- production liner: will be set just into the Kekituk zone #1 allowing sufficient sump to log the zone #2 reservoir.
- production tubing: the production tubing size dictates the subsequent casing sizes and varies for each well type:
 - oil producers - predominantly 4-1/2 inch tubing hence an ultra-slimhole casing design i.e. 9-5/8 inch surface; 7 inch intermediate; 4-1/2 inch liner. Some of the early oil producers may have 5-1/2 inch tubing to enhance early oil production hence a slimhole design i.e. 10-3/4 inch surface; 7-5/8 inch intermediate; 5-1/2 inch liner.
 - water injectors - 5-1/2 inch tubing required, hence slimhole design will be utilized i.e. 10-3/4 inch surface; 7-5/8 inch intermediate; 5-1/2 inch liner. The flank injectors are unlikely to require profile modification and so longstring slimhole wells will be utilized i.e. 10-3/4 inch surface; 7-5/8 inch intermediate to TD. The more crestal injectors may require future intervention for profile modification and so a 5-1/2 inch production liner will be set.
 - gas injectors - 5-1/2 inch tubing is required hence slimhole design will be utilized.

7.4.2 Directional Drilling and Surveying

The preliminary well profiles will all be build and hold through the reservoir section with sail angles below 65 degrees which will allow for wireline and/or coiled tubing intervention on all wells. Kick-off depths will be staggered at approximately 1500 feet TVD and the build rates will be provisionally planned at 2.5 degrees/100 feet maximum for surface and intermediate hole sections. The spider plot of Liberty locations and well trajectories is shown in Figure 3-2. The wells are within a two-mile radius of the island. Table 3-1 lists the true vertical and measured depths for all the wells.

7.4.3 Drilling Fluids & Cementing

Drilling Fluids

Drilling fluids for Liberty will be seawater based, which differs from the normal North Slope drilling fluids which are freshwater based. Given the location of Liberty Island with no year-round supply of fresh water available and limited storage capacity on the island, the freshwater mud systems are not considered a viable option. (Additional information about drilling fluids is included in Appendix A.) The surface hole will be drilled with a seawater spud mud with the required viscosity for effective hole cleaning. Lost circulation materials may be

required. The intermediate hole will be drilled with a non-dispersed low solids seawater/polymer mud with the mud weight being raised to 10.4 ppg prior to drilling the HRZ Shale. The reservoir interval will be drilled with the same system as in the intermediate hole but with a density of 9.4 ppg. A designer drill-in fluid may be considered if studies indicate a need.

Cementing

The cementing program will be based on current North Slope practices. It is anticipated that the surface casing job will utilize excess slurry along with two stage cementing equipment in order to ensure cement slurry back to island surface. The intermediate casing cement will be displaced 1500 feet above the shoe or above top hydrocarbon bearing zone for longstring well designs. Liners will be completely cemented.

7.4.4 Data Acquisition

There will be an electric wireline logging unit on the island to support drilling and completion operations. Open hole logging is anticipated in some upper hole sections and all production hole sections. Some cased hole logging operations will also be carried out. LWD (logging while drilling) may also be utilized.

7.5 COMPLETION DESIGN

Monobore completion strings are planned for oil producers, gas injectors and some water injectors i.e. same size tubing as production liner. This, coupled with relatively low sail angles, will allow profile modification with wireline or coiled tubing techniques. The exception is the flank water injectors where intervention is anticipated to be minimal and hence longstring design will be utilized. Here the 5-1/2 inch tubing will set inside the 7-5/8 inch intermediate casing.

The injectors, both gas and water, will have L80 carbon steel metallurgy throughout the liner, tubing and wellhead/Xmas tree. Oil producers will have 13% Cr steel metallurgy throughout the liner, tubing and wellhead/Xmas tree trim.

The producers and pre-produced gas injector will have surface controlled subsurface safety valves (SSSV). The injectors will have injection valves installed. All SSSV's and check valves will be wireline retrievable. Diagrams of the proposed completion designs are shown in Figures 7-1 through 7-4. All completion and wellhead/Xmas tree equipment will be 5,000 psi rated.

7.6 WASTE MANAGEMENT

Given the remoteness of Liberty to the existing North Slope infrastructure, the processing and disposal of drilling, camp and production waste must be carried out at the island. Minimizing all waste volumes generated will be a priority. Drilling waste management for the Liberty development is a critical process in the drilling operation. Waste disposal must take place concurrently with waste generation as limited cuttings or fluids storage area exist on the island to

accommodate a backlog waiting processing. Section 12 discusses Liberty waste management in more detail.

7.6.1 Disposal Well

The largest waste stream generated during drilling operations is drilling fluid and drilled cuttings. A waste disposal well will be the first well to be drilled at Liberty so that cuttings and fluids from subsequent wells can be processed through the grind and inject facility and disposed down the well. The cuttings and fluids from the disposal well will be transported via ice road to an approved disposal site in the Prudhoe Bay area. As an option, the cuttings and waste mud can be temporarily stored on the Liberty pad for disposal at a later date, either on the Liberty island or at a Prudhoe Bay area facility. Any temporary storage on the Liberty island would be in a bermed, lined area. Once the disposal well and injection facilities are commissioned, drilling wastes will be disposed of downhole in the disposal well. The disposal well preliminary design and injection parameters are described in Appendix A.

Two disposal wells will be permitted but only one will be drilled initially. The second well will only be drilled if the original well becomes damaged or unusable beyond repair. As a contingency, disposal permits for annular injection will be obtained with each permit to drill application. If the disposal well experiences downtime, drill fluids and cuttings can be processed and disposed of via annular injection.

7.6.2 Cuttings Processing and Injection Equipment

Cuttings will be processed by a ball mill or similar grinding equipment to a size capable of injecting down the disposal well. A size classification system using screens and/or hydrocyclones will allow the finely ground cuttings to pass onto the injection pump, while routing the larger cuttings particles to the grinding equipment for further size reduction. Cuttings and mud will be mixed in a slurry and injected by pumping down the disposal well. The mud and cuttings drilling wastes will be processed real-time with the drilling operation (no long term onsite storage available). The mud and cuttings processing equipment may either be part of the rig equipment or a separate stand-alone facility, depending on the exact rig selected.

7.7 LOGISTICS

7.7.1 General

As described in Section 4, because Liberty is not connected by road to the existing North Slope infrastructure, the drilling operation will rely heavily on the ability of storing sufficient drilling equipment and consumables on site for the periods of non-supply between ice roads (January to April-May) and open water season (July to September).

The drilling rig and ancillary equipment will be mobilized via barge to the Liberty island in the summer of Year 2. Drilling consumables (casing, tubing, mud, cement) will initially be transported to the Liberty island to allow drilling to commence in January Year 3. Each spring

prior to break-up and each fall prior to freeze-up, consumables will be re-supplied to allow drilling to continue through these broken ice periods. Re-supply will occur via barge in the summer and by ice road in the winter. Personnel, lighter-weight equipment and freight (including groceries) will be supplied by helicopter. It is intended that the helicopter selected will be capable of under-slinging loads such that drilling, facilities and production spares or replacement equipment can be obtained from the North Slope.

Island Storage Requirements

The drilling footprint on the island will be used for storage of the following items in addition to the rig and its movements:

- Bulk Plant: the plant will include an enclosed cutting station, compressor and small electrical generator to supply power for lights and heat. It is intended that bulks will be blown from the plant to the rig/cement unit during cementing operations.
- Mud Materials: storage silos will be dedicated for barite as well as 1-ton bags. Included in the volume of barite to be stored will be an amount sufficient to increase mud density to handle a well control situation on the longest well drilled immediately prior to a re-supply period.
- Cement Materials: storage silos will be dedicated for cement storage as well as 1-ton bags. Also included will be a scale tank, blend tank, cutting station and required support equipment.
- Tubulars: will be stored in racks on the island.
- Completion Equipment and Wellheads/Xmas Trees: an area will be required for trees and wellheads, packer, safety valves, gas lift mandrels and other completion equipment.
- Diesel Storage: after startup diesel will be provided to drilling from the facilities diesel storage tank.
- Cement Unit: an electric cement unit will be located on the island to support drilling and completion operations.
- Logging Unit and Service Building: an electric logging unit will be located on the island to support drilling and completion operations.

In addition, during the winters when production well drilling is occurring, an additional storage area of approximately 350 by 700 feet will be built on the sea ice on the east side of the island. This site would be used to store tubulars and other clean materials.

7.8 WELL CONTROL

The primary well control for Liberty development drilling program will be the drilling fluid weight used, which will be based on appraisal well data from the Liberty #1 well and from other exploratory wells drilled from Tern Island, plus the nearby Endicott field analogue. The secondary well control equipment is as described in the drilling unit section. In addition to this, the experienced BPXA and North Slope drilling contractor personnel will be certified in

accordance with 30 CFR 250 Subpart O. They will also be using established formal procedures and guidelines to ensure all well control instances are addressed immediately and adequate resources of both personnel and equipment are promptly employed to mitigate the occurrence of a loss of well control (blowout). Provisions for a relief well are discussed in detail in the Liberty Oil Spill Contingency Plan.

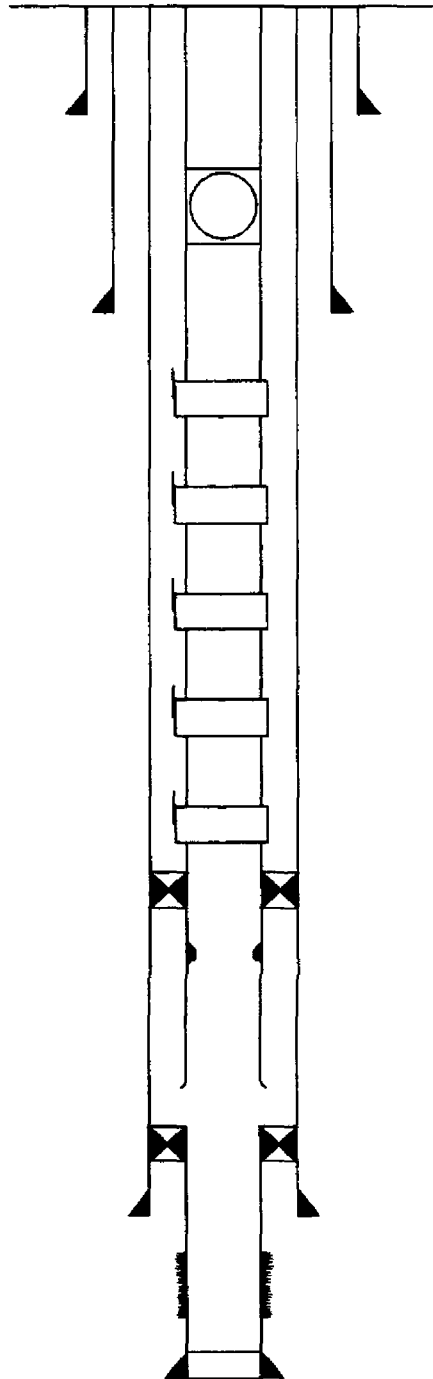

| | |
|---|-------|
| | TVD |
| 20" conductor | 200' |
| 4½" WR SSSV | |
| 9¾" surface casing | 4700' |
| Gas lift mandrel | |
| 4½" 13Cr tubing downdip | |
| 4½" L-80 tubing updip | |
| Hydraulic set 13Cr permanent latched packer | |
| XN nipple | |
| 7" casing | |
| 4½" liner | |

BP EXPLORATION (ALASKA) INC.

LIBERTY DEVELOPMENT PROJECT
4½" MONOBORE PRODUCER

| | | |
|-----------------------|---------------|----------------|
| DATE: January 1998 | SCALE: N/A | FIGURE: 7-1 |
|-----------------------|---------------|----------------|

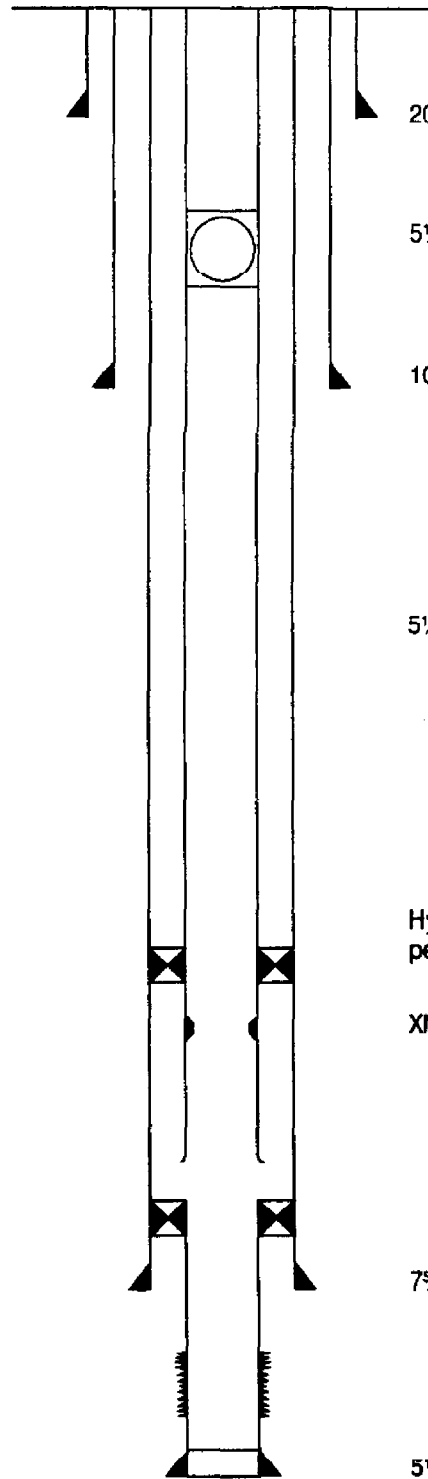

TVD

20" conductor

200'

5½" WR SSSV

10¾" surface casing

4700'

5½" L-80 tubing

Hydraulic set
permanent latched packer

XN nipple

7½" casing

5½" liner

BP EXPLORATION (ALASKA) INC.

LIBERTY DEVELOPMENT PROJECT

5½" PRE PRODUCED

GAS INJECTOR

DATE:
January 1998

SCALE:
N/A

FIGURE:
7-2

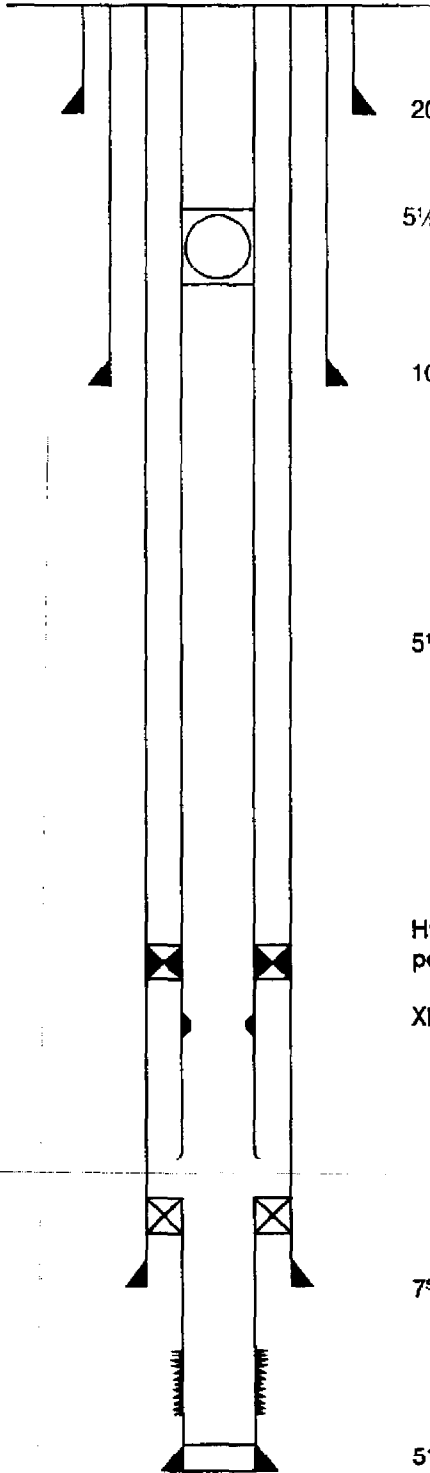

TVD

20" conductor 200'

5½" WR injection valve

10¾" surface casing 4700'

5½" L-80 tubing

Hydraulic set
permanent latched packer

XN nipple

7½" casing

5½" liner

| | | |
|-------------------------------------|---------------|----------------|
| BP EXPLORATION (ALASKA) INC. | | |
| LIBERTY DEVELOPMENT PROJECT | | |
| 5½" GAS INJECTOR | | |
| DATE: January 1998 | SCALE: N/A | FIGURE: 7-3 |

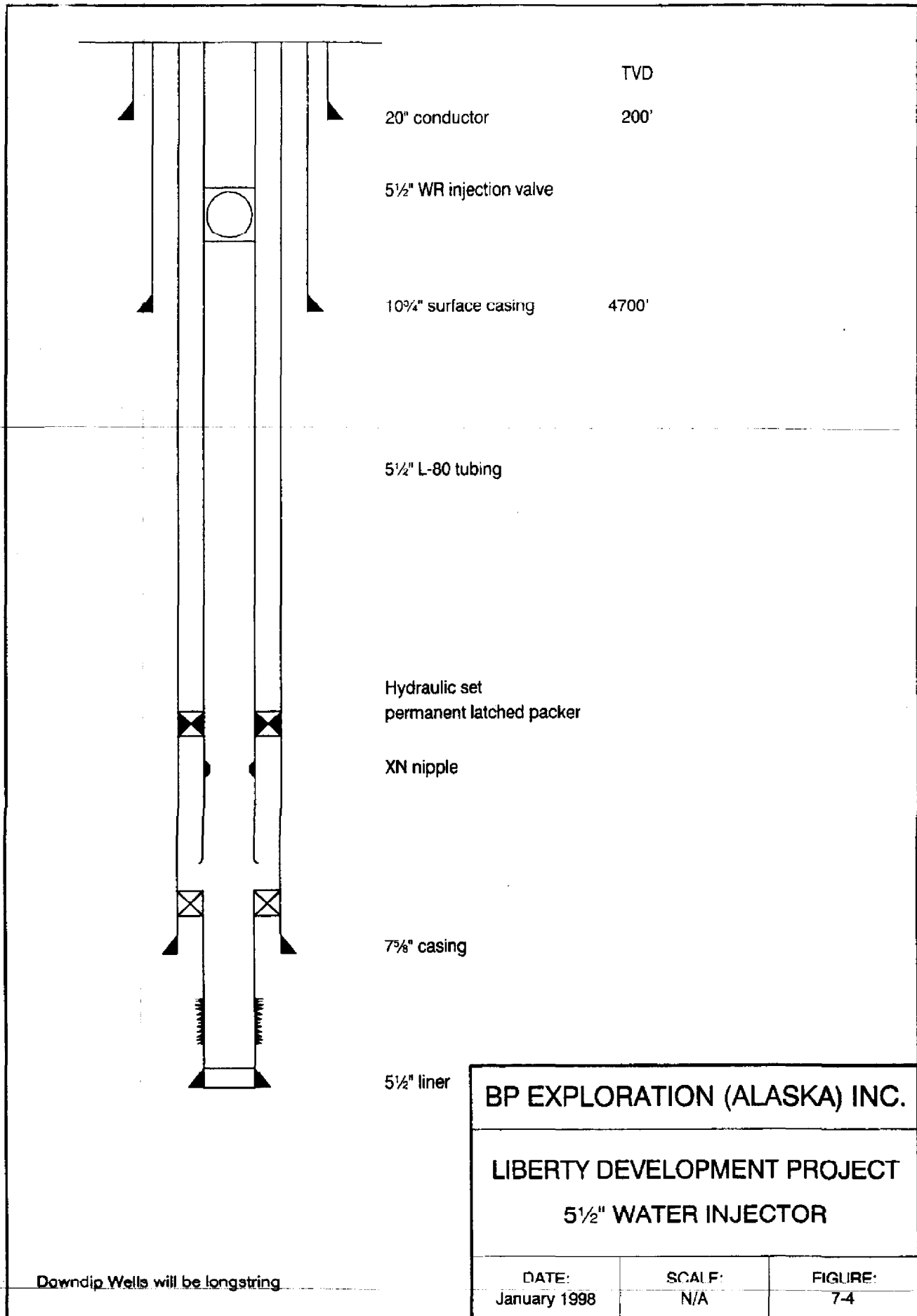

| | | |
|------------------------------|---------------|----------------|
| BP EXPLORATION (ALASKA) INC. | | |
| LIBERTY DEVELOPMENT PROJECT | | |
| 5 1/2" WATER INJECTOR | | |
| DATE: January 1998 | SCALE: N/A | FIGURE: 7-4 |

8. PIPELINE SYSTEM

This section provides a summary of the proposed Liberty pipeline system. More detailed information is provided in the Application for Pipeline Right-of-Way submitted to the Alaska State Pipeline Coordinator's Office (including supporting documents), and in the Pipeline Right-of-Way application submitted to MMS.

8.1 PIPELINE ROUTE

The proposed project pipeline route is shown in Exhibit A and in Figure 1-1. The pipeline route is divided into two segments: offshore and onshore.

The offshore route segment is a nearly straight route from the Liberty Production Island to a landfall located about 6.1 miles to the south-southwest of the island. During preliminary engineering, the offshore route selection was based on preliminary bathymetric data, avoidance of strudel scour zones, avoidance of the Boulder Patch, and on landfall siting criteria, including a location with relatively low coastal erosion rates (long term rate of 2.0 to 3.0 feet per year), the need for a high bank, avoidance of archaeological and cultural sites, and avoidance of salt marsh.

The overland route is approximately 1.5 miles long. It extends south to a tie-in with the proposed Badami sales oil pipeline approximately 1.5 miles west of the Kadleroshilik River. The overland route avoids major lakes, and intersects the Badami pipeline at a new gravel pad.

8.2 DESIGN

Design features for the sales oil pipeline include:

- design flowrate: 65,000 barrels per day
- maximum operating pressure: 1415 psig
- nominal diameter: 12 inches (12.75 inch outside diameter)
- wall thickness (offshore): 0.688 inch
- wall thickness (onshore): 0.281 inch
- pipeline material grade (offshore): API-5L X-52
- pipeline material grade (onshore): API-5L X-65

The onshore portion of the sales oil pipeline will be elevated on standard VSMs, and will have polyurethane foam insulation. Expansion loops will be in an "L" loop configuration, spaced approximately 3,300 feet apart. The pipeline will have a minimum elevation of five feet above the tundra surface.

Automated pipeline isolation valves will be located on the Liberty Production Island and at the Badami tie-in point. At the landfall, an automated isolation valve will be included as part of the pipeline system. Vertical loops are also being considered; these are technically feasible for the shore crossing for Liberty because of the small elevation change along the proposed overland

route (26 feet maximum elevation above sea level) plus the short distance to the Badami tie-in point (about 1.5 miles away). Final selection of a vertical loop versus an automated isolation valve at the shore crossing will be made during the final pipeline design.

New gravel pads will be constructed at the Badami Pipeline tie-in and at the landfall. The landfall pad would be approximately 135 feet by 97 feet, requiring approximately 2,400 cubic yards of gravel; the tie-in pad will be approximately 170 feet by 155 feet, requiring approximately 3,500 cubic yards of gravel. If the vertical loop option is selected, the size of the landfall pad would be probably be reduced. Gravel for both pads will be obtained from the proposed Liberty mine site. Given the exposed nature of the shore crossing and the proximity to the coastline, the RTU facilities will likely need to be contained in an enclosure. However, if a vertical loop were utilized, the enclosure would not be necessary. Provision for pigging the oil pipeline will be provided.

Mass Balance Line Pack Compensation (MBLPC) and Pressure Point Analysis (PPA) leak detection systems will be incorporated into the pipeline design. These systems would work in parallel and provide a redundancy. It is expected that under optimal conditions, these systems would be capable of detecting a leak of as little as 0.15% of volumetric flow in the pipeline. Custody transfer metering will be located on the Liberty Island and a flow meter will be located at the tie-in with the Badami Pipeline to enhance the performance of the leak detection system. Communication links to interface with the Badami and Endicott pipeline leak detection systems and controls will also be provided.

The Liberty project will also incorporate a supplemental leak detection system in its pipeline design. A wide range of leak sensors and leak detection systems was evaluated for the Northstar project and the LEOS system will be installed with the pipeline bundle of that project. Liberty proposes to use LEOS or a similar system incorporating any "lessons learned" from the Northstar project. Such a leak detection system would be capable of detecting hydrocarbon concentrations resulting from leaks less than one barrel of oil per day.

The maximum worst-case spill volume for the pipeline is estimated to be limited to about 1580 barrels. This estimate is based on the worst-case assumption of a guillotine break in the pipe. For a leak less than the combined MBLPC and PPA leak detection threshold, a very small leak (97.5 barrels/day = 0.15% of flow) would only occur over a period of 24 hours prior to detection by the supplemental leak detection system. This scenario would result in an oil loss of about 128 barrels of oil (see OSCP for more information). Details on the installation of these leak detection systems will be provided in the supporting documentation for the application for pipeline right-of-way.

BPXA is committed to continue design evaluation and to identify operational measures that can be implemented as a means of further reducing these worst-case pipeline leak estimates. Such measures include surveillance of the pipeline route, operator monitoring and investigation of suspected imbalances, more frequent meter proving, and implementing operational procedures for pipeline shut-down in the event a leak below the detection limits is suspected but not indicated by the leak detection systems.

The offshore buried pipeline will approach the island in the trench. A pull tube will be used to transition the pipeline from the buried offshore mode to the working surface of the Liberty Island (Figure 8-1).

After construction, the permanent operational right-of-way will include about 37 acres of the OCS, and about 130 acres of State of Alaska lands and waters.

8.3 CONSTRUCTION

The pipeline will be constructed during the winter within a proposed temporary construction right-of-way (250 feet wide onshore, 1500 feet wide offshore). An ice road and/or thickened sea ice will be built within the construction right-of-way to support pipeline construction. An additional temporary site for welding of offshore pipeline strings will be required. This site will be located close to shore on grounded sea ice (generally less than 5.5 feet water depth), artificially thickened as required to support construction equipment (to about 8 feet), on the east side of the pipeline right-of-way. Approximate dimensions of the make-up pad will be 6,000 feet long by 750 feet wide. Also, a 2,000 by 5,000 foot site has been identified as an area (Zone 1) for temporary storage of material excavated from the pipeline trench and as the area for potential disposal of any excess excavated material that cannot be used as backfill in the pipeline trench (Figure 8-2).

Onshore

The overland portion of the pipeline will be supported on VSMs from the transition point between buried and elevated mode to the tie-in with the Badami Sales Oil Pipeline. The above-ground pipeline will include expansion loops or offsets to account for thermal expansion (or contraction) of the pipeline. The bottom of the pipeline will be elevated a minimum of five feet above the tundra surface. Design and installation of the VSMs will be completed following typical procedures used for other elevated pipelines on the North Slope. The VSM piles will be set using a sand slurry.

Offshore and Shore Transition

Offshore, the pipeline will be buried in a trench. The proposed depth of cover over the 12-inch pipeline is a minimum of seven feet (Figures 8-3 and 8-4). Depth of cover is defined as the distance from the original seabed to the top of pipe. In addition, the pipeline will be buried from the shoreline to an inland point where the pipeline transitions from buried to elevated mode.

The transition point will be located to provide protection from coastal erosion expected during the pipeline design life, plus a safety factor (Figures 8-5 and 8-6). This set back accounts for the average long term erosion rate and the maximum expected short term erosion rate. BPXA estimates long term (period from 1949 to 1995) erosion rates of about 2.0 to 3.0 feet per year and short term erosion rates of 12 feet per year at the shore crossing location. The proposed length of the onshore setback is approximately 150 feet (from the 4 foot elevation to the shoreward toe of

the pad). This set back distance also accounts for any ice ride-up in conjunction with the expected coastal erosion.

The transition trench will be up to 250 feet long and as wide as 25 feet at the top. Select backfill (thaw stable material) will be used as necessary to minimize thaw settlement in the transition zone between the offshore segment and the onshore segment (Figure 8-7). The quantity of select backfill expected to be required, based on trench geometry, is approximately 2,800 cubic yards. Valve pads will be located at the landfall transition point if a valve is included in the design at this location (Figures 8-5 and 8-6), and at the tie-in (Figures 8-8 and 8-9).

After laying the pipeline, the trench will be refilled. Cuttings from VSM installation may also be placed in the onshore portion of the trench. In the onshore portion of the trench, the backfill will be topped with a veneer of fine-grained soils and organics, and seeded as needed to promote revegetation. Coarser granular material from the gravel mine or the excavation will be used at the shore crossing as needed to achieve erosion resistance similar to the adjacent, undisturbed material. This plan minimizes any increase in erosion due to construction through coastal bluffs.

Offshore Trenching

The trench in which the offshore pipeline will be laid will be excavated through the sea ice in the winter. The execution sequence of the trenching and pipelaying operations is as follows:

- Thicken sea ice along route. This is required to support the excavation equipment. (Note: where bottomfast ice is present, thickening of the sea ice is not anticipated.)
- Cut a slot in the ice. The slot will be approximately 10 feet wide. The ice will be either cut into blocks using an ice trencher and removed by conventional excavation equipment. The blocks will be transported to a location away from the work site to prevent excessive deflection of the ice in the work area as needed.
- Excavate the trench using conventional excavation equipment. This equipment will include a hydraulic (suction pump) dredge attachment on a backhoe. Excavated material will be backfilled over the pipeline in another area of the trench, or stockpiled in a designated area.

Hydraulic dredging will be used as an alternative to a bucket backhoe, particularly when needed to achieve trench bottom smoothness criteria for pipe integrity, and in cases where slumping of trench side walls requires hydraulic cleanout. It is estimated the hydraulic dredge would be used 5 to 10 percent of the time. Actual use rates and locations of use would be determined by field conditions.

Offshore Pipeline Installation

Pipeline installation will follow immediately behind the trenching spread. One or both of the following techniques will be used to assemble the pipelines: (1) lay and weld, or (2) prefabricate and transport pipeline strings. For the lay and weld method, a sideboom or crane will unload pipe joints from transport vehicles and string the pipe joints end to end along the right-of-way. Each pipe joint is then welded into the pipeline near its final as-laid position. Alternatively,

the pipe joints will be welded into strings up to one mile in length at the make-up site and these strings would be pulled into place and welded onto the end of the pipeline. In both cases, testing of the completed welds would be performed using non-destructive techniques. Field joints will be coated with a corrosion protection coating and cathodic protection anodes will be installed at the designated spacing. Side booms will be then used to control the vertical and horizontal position of the pipeline down through the water column to the trench bottom. Pipelaying will advance at the rate of trench excavation.

Offshore Trench Backfill

If practical, once construction is underway recently excavated trench spoils will be transported and placed as backfill over recently-laid pipeline segments in a continuous process. In initial stages of construction, however, the spoils excavated from the trench will be temporarily stockpiled. As much of spoils as possible will later be removed from the stockpile and transported to be placed in the trench as backfill. After installation of the pipeline, the spoil will be then replaced in the trench. For safety and flexibility two stockpile locations have been identified (Zone 1 and Zone 2), as shown in Figure 8-2.

Trench backfill will include both native spoils as well as select backfill. Select backfill will include gravel and gravel-filled polyester bags, and is needed to assure pipeline stability in the trench during construction and operation. Loose gravel will be used as trench fill material where needed for pipeline stability during construction. Gravel-filled geotextile bags will be placed axially across the pipeline in the trench (Figure 8-10) providing uplift resistance during operation. The bags would then be buried within the remaining backfill material. Using this method, bags would be buried well below the seafloor, and would not be exposed to ice or erosion forces. Bags would be placed as required during construction, depending on the pipeline as-laid configuration (as estimated maximum coverage of 50 percent of the pipeline route is assumed). The bags would be installed using tongs, according to the same general method used to install bags in the island slope protection system. These tongs are specially designed to avoid damaging or breaking the bags.

Table 8-1 lists estimated excavation and backfill quantities, including volumes for the design trench, and excavation limit volumes. The design trench reflects expected construction conditions; the trench excavation limits (Figures 8-3 and 8-4) are a reasonable upper limit estimate to account for uncertainties in actual field conditions and for constructability. This estimate takes into account the potential for the trench walls to form at shallower angles than cut, and allows for the potential for over-excavation if required. For calculation purposes, it has been assumed that the average trench side angle of repose is no more than 1:5.

Excess Backfill Disposal

In the process of trench excavation, BPXA intends to minimize the amount of construction spoil requiring disposal by re-using this material as trench backfill to the maximum extent possible. It is also possible that portions of the ice slot could be reopened and excess spoils placed over the previously backfilled trench to eliminate or further reduce the volume requiring disposal. There are conditions, though, under which some excavated material cannot be

placed back into the trench and will require disposal. One case is where the quantity of excess spoil is greater than can be accommodated over the trench without over-mounding. The amount of mounding over the pipeline is a potential environmental concern. In the area of grounded ice construction (to about the 8-foot isobath), the cap of the backfill will be close to the original seafloor, and will not be greater than 1-foot higher than the original seafloor. A criterion of 2-foot of trench mounding (above original seafloor) has been set for waters outside the 8-foot isobath.

Situations requiring disposal of excess backfill may result due to several factors, including displacement by the pipeline, the use of select backfill (e.g. gravel) when required, and bulking due to the natural swell of excavated materials placed back into the trench. Another case may result from uncontrolled circumstances (e.g., bad weather) that may force construction crews to abandon the site before all operations have been completed, leaving some excavated material on the ice surface. Depending on site specific circumstances, ocean disposal of up to 110,000 cubic yards of dredged material spoils may be required.

Two sites for spoil storage and possible disposal are proposed (Figure 8-2). The first storage site (Zone 1) will be located on the west side of the pipeline right-of-way on grounded sea ice outside the 5-foot isobath. Approximate maximum dimensions of the site will be 5,000 feet by 2,000 feet (230 acres). Zone 1 will serve as the temporary storage location for materials excavated during trenching operations that cannot be directly transported for backfill along the pipeline. BPXA intends to reuse excavated material as pipeline trench backfill to the maximum extent practicable. For excavated spoils that cannot be used as backfill, Zone 1 will serve as the designated disposal site. It will also be the disposal location of materials temporarily stored there if the weather or ice conditions dictate the abandonment of operations prior to completion.

Spoils placed in Zone 1 will be groomed to an average depth of approximately one foot to minimize the potential for mounding on the sea floor once disposed of. The size of the site was selected to provide operational flexibility, and the entire site will not be used for disposal. Material will be stacked on portions of the site over deeper water first, then over shallower water. The maximum quantity of spoils stockpiled or left for disposal on this site at any one time is estimated at 100,000 cubic yards. Assuming that this maximum quantity of up to 100,000 cubic yards of spoils would be disposed of on the site in one foot high stacks, about 27 percent of Zone 1 (about 62 acres) would be used for actual disposal.

Zone 1 was selected based on results of BPXA Boulder Patch surveys and ongoing agency coordination and guidance. A major criterion used in selecting the 5,000 by 2,000 foot site was avoidance of impacts to the Boulder Patch habitats, by not placing the disposal site directly over known Boulder Patch, and maintaining distance from known Boulder Patch to minimize any effects from the disposal activity, given consideration of normal oceanographic conditions. Other important criteria include maintaining a safe distance from active pipelaying operations, reasonable hauling distance, water depth greater than five feet, and local fate and transport mechanisms.

The second disposal site (Zone 2) is a 200-foot wide section along the west side of the pipeline trench from the island to shore. Zone 2a is that segment in water depths less than approximately 16 feet; Zone 2b is that segment located on floating ice, in water depths greater than 16 feet.

Zone 2 is an additional stockpile location and would be used as a disposal location for stockpiled excavated materials in the event weather or ice conditions dictate the abandonment of operations prior to completion. The maximum quantity of spoils stockpiled or left for disposal on this site at any one time is estimated at 10,000 cubic yards. Spoils in Zone 2a will normally be stacked or groomed to maintain an approximate depth of one foot. Spoils placed in Zone 2b will be stacked or groomed to an average depth less than 2 feet. It is BPXA's intent to clear Zone 2 of all construction spoils at the end of construction. This will be accomplished by scraping the ice with heavy equipment, leaving at most, a veneer of dirty ice → a very small amount of sediment remaining in the frozen matrix.

Unfavorable weather may prevent the transportation of all the temporarily stored spoils back to the open trench section, resulting in sections of the trench not being fully backfilled. Trench conditions would be evaluated the following summer, and the need for any additional backfill would be determined.

Pipeline/Island Transition

A pull tube will be used to transition the pipeline from the buried subsea mode onto the island surface (Figure 8-1). As the island is being constructed, the area where the pull tube will be installed will be left open. The tube will then be placed in the island, with limited reworking needed to properly position the tube. Fill will then be placed around the tube to complete the island. Minor seafloor excavation will be required as part of island construction to install the pull tube, which will extend out from under the toe of the island and will be buried in the seafloor.

During pipeline construction, a steel cable will be pulled through the pull tube from the island to the ice sheet. The cable will be attached to the end of the last pipeline string. The pipeline string will be lowered to the bottom of the pre-excavated trench, and winched toward the entrance of the pull tube and up through the pull tube almost to the top of the tube. The final tie-in welds will be made on the ice sheet after which the pipeline will be winched completely up through the pull tube. At the same time, the offshore pipeline will be lowered into the trench.

Pipeline Temporary Abandonment

It is possible that weather or ice conditions could dictate a temporary or seasonal abandonment of the pipeline before construction is completed. Therefore, there will be an abandonment and recovery plan in place for the Liberty offshore pipeline. Abandonment of stockpiled soil is covered in the above subsection on "Excess Backfill Disposal".

The offshore pipeline will be installed into the excavated trench using sidebooms equipped with roller cradles. Approximately four sidebooms with a predetermined spacing and with predetermined cradle elevations will progressively lower the pipeline into the trench while maintaining their spacing and elevations as the sidebooms proceed along the pipeline trench.

If the pipeline must be abandoned, an abandonment head will be welded to the pipe and a cable will be attached to the head. This cable will then be maintained at a predetermined tension and the sidebooms advanced in the same manner as for regular pipeline installation until the end of the pipeline approaches the first sideboom. The sidebooms will then proceed to lower the roller cradles to predetermined abandonment elevations. At this point, the sidebooms will resume moving along the trench in the pipelay direction, the pipeline end will pass the rollers, and the abandonment cable (tensioned) will ensure a controlled laydown of the pipeline. The cable will remain attached to the pipe end and the recovery of the pipeline would be performed in the reverse sequence as the abandonment. The abandonment head welded to the pipeline end will have a shape that ensures a smooth transition from the small cable diameter to the larger pipeline diameter. A smooth transition is needed to prevent the pipeline from jumping from the roller during abandonment and to guide the rollers below the pipeline during recovery.

The cable would then be slackened and lowered into the trench in the case of a seasonal abandonment. Recovery from a seasonal abandonment may require divers to recover the cable and excavate any soil deposited over the pipeline using hand jetting equipment.

Hydrotesting

Hydrotesting of the pipelines will be completed by May Year 3. Several options for test fluids are being considered, including glycol, a water/glycol mixture, or seawater. If any glycol is used, the test fluids would be recovered and returned to the vendor for future use, recycling, or approved disposal. If seawater is used it will be discharged in accordance with the terms of a General NPDES permit.

8.4 SAFETY AND LEAK PREVENTION MEASURES

The proposed Liberty pipeline includes the following measures to assure safety and leak prevention:

- The pipeline route in Foggy Island Bay is shoreward of the barrier islands, thus affording protection from large ice keels which could gouge the seabed.
- The present design calls for trenching the pipeline in the seabed so that the top of pipe is at least seven feet below the original seabed (this is more than 5 times the deepest measured ice gouge in the vicinity of the pipeline route). The trench will then be backfilled over the top of the pipes.
- The oil pipeline will have much more wall thickness (over 2.5 times) than design codes require for internal pressure. This adds weight and also makes the pipe stronger. The oil pipeline will have thicker walls than the 48-inch diameter Trans-Alaska Pipeline.
- The pipeline is designed to accommodate severe bends without leaking in the event of an ice keel or in the event of the predicted maximum permafrost thaw subsidence.
- The pipelines will be coated on the outside and protected with anodes to prevent corrosion.

- The shore transition is buried to protect against storms, ice pile-up, and coastal erosion. The shore transition valve pad will be elevated and set back from the shoreline.
- A best available technology leak detection system will be used during operations to monitor for any potential leaks (see OSCP for more detail).
- A supplemental leak detection system may be incorporated into the pipeline design building on the experience and lessons learned from Northstar.
- Intelligent inspection pigs will be run during operations to monitor pipe conditions and measure any changes.
- The elevated overland pipeline section will be conventional, proven North Slope design.
- The line is designed with no flanges, valves, or fittings in the subsea section to eliminate the possibility of leaks from such components.

8.5 MONITORING AND SURVEILLANCE

BPXA will conduct long-term monitoring and surveillance of the pipeline system. The purpose of this monitoring and surveillance program will be to assure design integrity and to detect any potential problems. The program will generally include visual inspections/aerial surveillance and pig inspections.

Visual inspections of the pipeline system will be conducted by aerial surveillance on a weekly basis. The goal of these surveys will be to visually detect a pipeline leak, either by evidence of a sheen on the water surface or by staining of the tundra or snow. Pipeline isolation valves will be inspected on a regular basis.

In addition to visual observations/inspections, BPXA will conduct a regular oil pipeline pig inspection program to assess continuing pipeline integrity. Three types of data collection pigs will be used:

- wall thickness measurement pigs
- 3D geometry pigs (axial, vertical, and lateral)
- mechanical damage pigs

The OSCP provides detailed information on the proposed pipeline surveillance and monitoring program.

**TABLE 8-1
PIPELINE TRENCH EXCAVATION AND BACKFILL VOLUMES**

| Pipeline Segment | Design Trench | Excavation Limit |
|--|----------------------|-------------------------|
| Offshore segment | | |
| Length (feet) | 32,400 (6.1 miles) | 32,400 (6.1 miles) |
| Excavation (cubic yards) | (323,000) | (724,000) |
| Maximum Native Backfill (cubic yards) ¹ | 256,000 | 657,000 |
| Maximum Select Backfill ² (cubic yards) | 67,000 | 67,000 |
| Affected Area (acres) | 39.5 | 73.6 |
| Onshore transition | | |
| Length (feet) | 150 (0.05 miles) | 150 (0.05 miles) |
| Excavation (cubic yards) | (1,900) | (2,200) |
| Maximum Native Backfill (cubic yards) ³ | 200 | 400 |
| Maximum Select Backfill ² (cubic yards) | 2,100 | 2,500 |
| Affected Area (acres) ⁴ | 0.2 | 0.3 |
| Total Pipeline | | |
| Length (feet) | 32,550 (6.15 miles) | 32,550 (6.15 miles) |
| Excavation (cubic yards) | (324,900) | (726,200) |
| Maximum Native Backfill (cubic yards) | 256,200 | 657,400 |
| Maximum Select Backfill (cubic yards) | 69,100 | 69,500 |
| Affected Area (acres) | 39.7 | 73.9 |

¹ Excess native offshore construction spoil (maximum 100,000 cubic yards) designated for ocean disposal

² Includes thaw stable gravel and gravel-filled bags

³ Excess native onshore construction spoil (maximum 400 cubic yards) designated for mine site backfill/rehabilitation

⁴ Includes extension of backfill "cap" beyond trench excavation limits

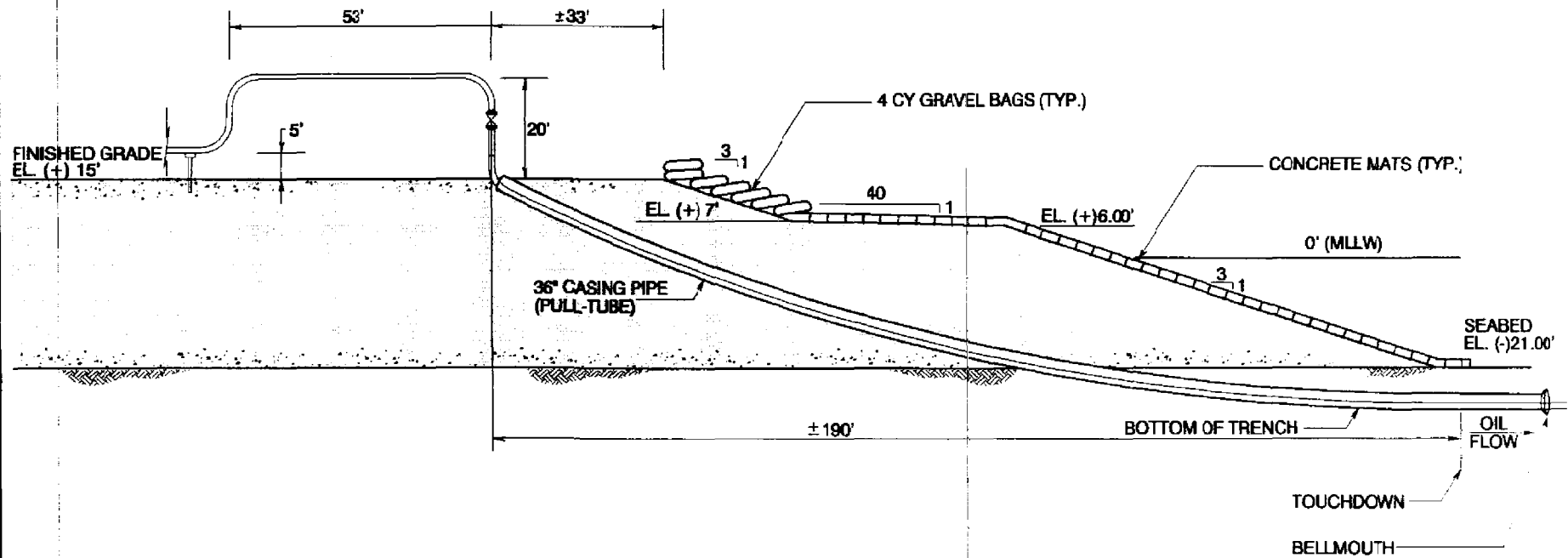

ALL DIMENSIONS ARE APPROXIMATE

BP EXPLORATION (ALASKA) INC.

LIBERTY DEVELOPMENT PROJECT
ISLAND APPROACH
CROSS - SECTION

DATE:
Rev. April 2000

SCALE:
NOT TO SCALE

FIGURE:
8-1

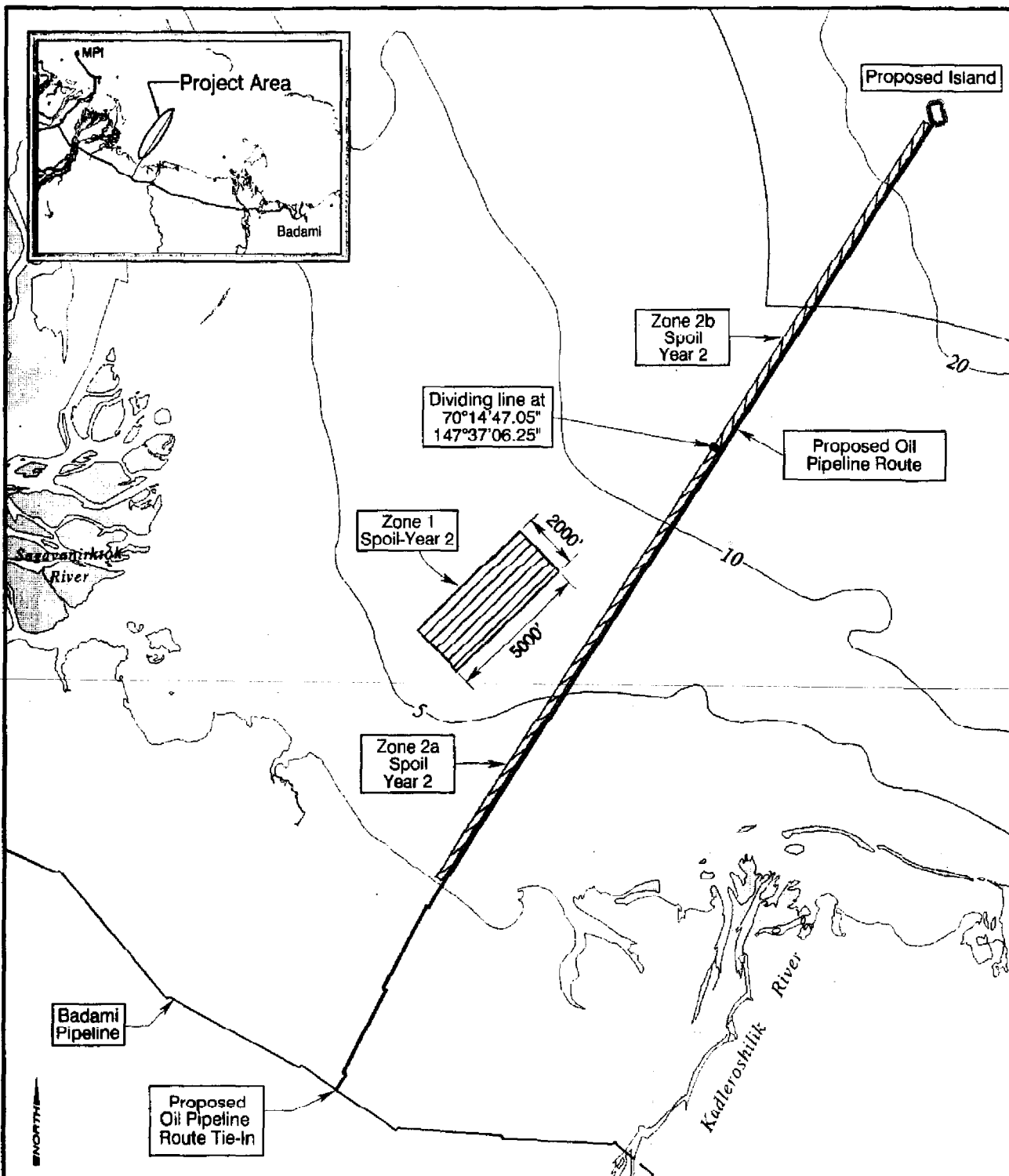

BP EXPLORATION (ALASKA) INC.

**LIBERTY DEVELOPMENT PROJECT
PROPOSED DREDGED MATERIAL
SITES ZONES 1 & 2**

DATE:
Rev. April 2000

SCALE:
1" = 5,000 Feet

FIGURE:
8-2

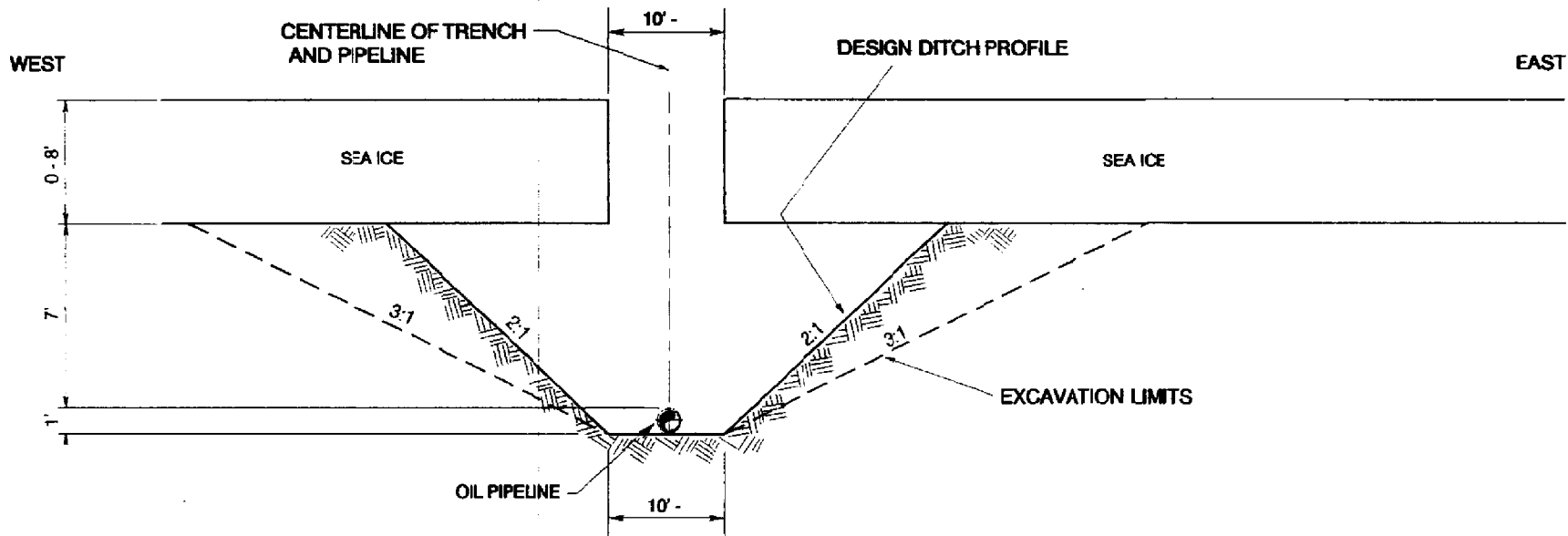

NOTES:

1. PIPELINE DEPTH OF COVER IS 7 FEET MINIMUM.
2. TRENCH SIDE SLOPES ARE VARIABLE, DEPENDING ON SOIL CONDITIONS.

ALL DIMENSIONS ARE APPROXIMATE

| | | |
|---|---------------|----------------|
| BP EXPLORATION (ALASKA) INC. | | |
| LIBERTY DEVELOPMENT PROJECT TRENCH SECTION SHALLOW AREA 0' - 8' | | |
| DATE: Rev April 2000 | SCALE: N/A | FIGURE: 8-3 |

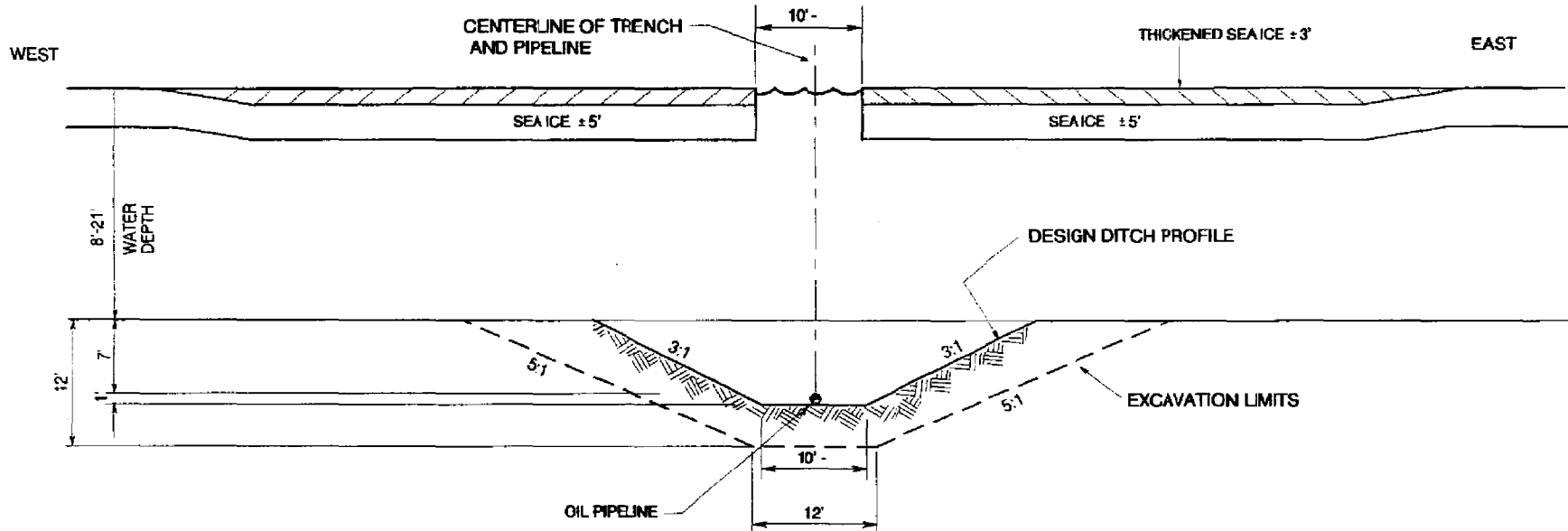

NOTES:

1. PIPELINE DEPTH OF COVER IS 7 FEET MINIMUM.
2. TRENCH SIDE SLOPES ARE VARIABLE, DEPENDING ON SOIL CONDITIONS.

ALL DIMENSIONS ARE APPROXIMATE

BP EXPLORATION (ALASKA) INC.

LIBERTY DEVELOPMENT PROJECT
 DEEP TRENCH
 INTERMEDIATE / DEEP AREA 8' - 21'

DATE:
 Rev. April 2000

SCALE:
 N/A

FIGURE:
 8-4

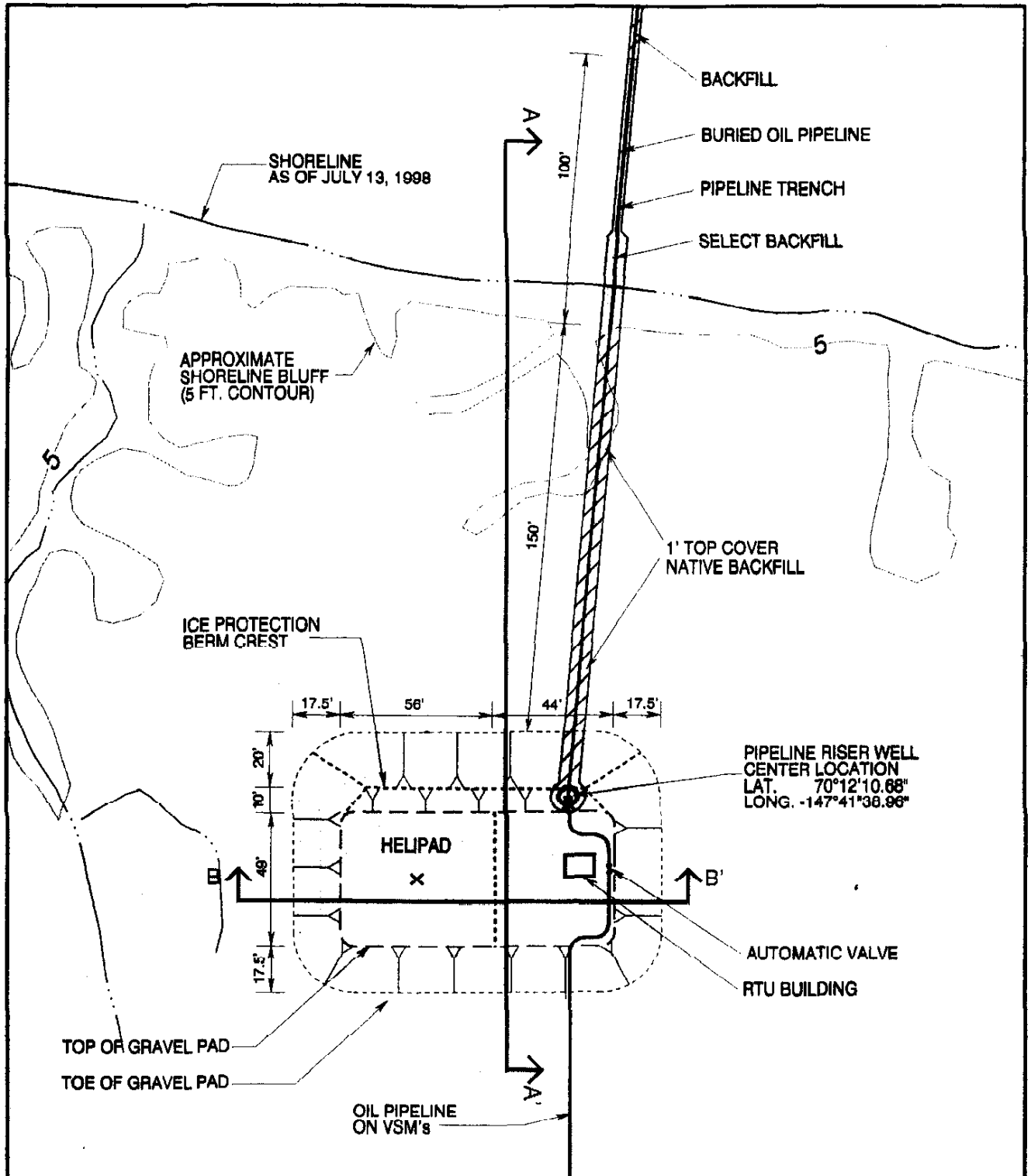

X PAD CENTROID
 LAT. 70°12'.10.6515"
 LONG. -147°41'.40.8034"
 NAD27

ALL DIMENSIONS ARE APPROXIMATE.
 LOCATION OF VALVES TO BE
 DETERMINED DURING DETAILED DESIGN.



| | | |
|--|------------------------|----------------|
| BP EXPLORATION (ALASKA) INC. | | |
| LIBERTY DEVELOPMENT PROJECT LANDFALL VALVE PAD LAYOUT | | |
| DATE: Rev. April 2000 | SCALE: NOT TO SCALE | FIGURE: 8-5 |

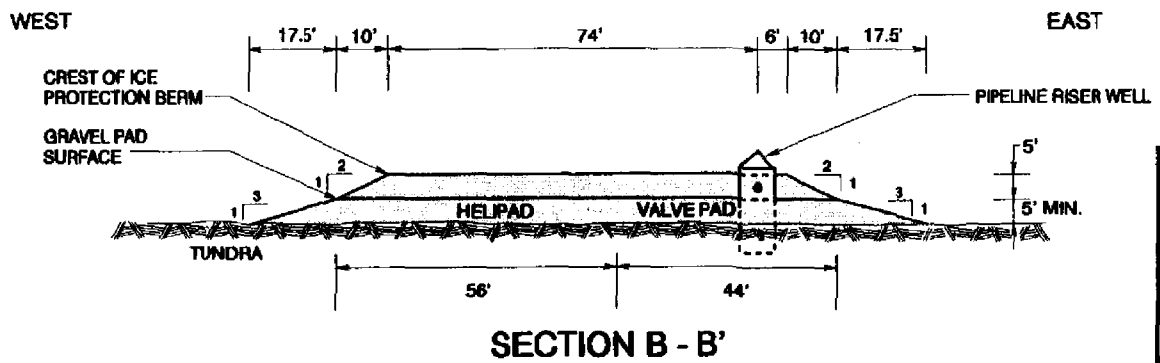
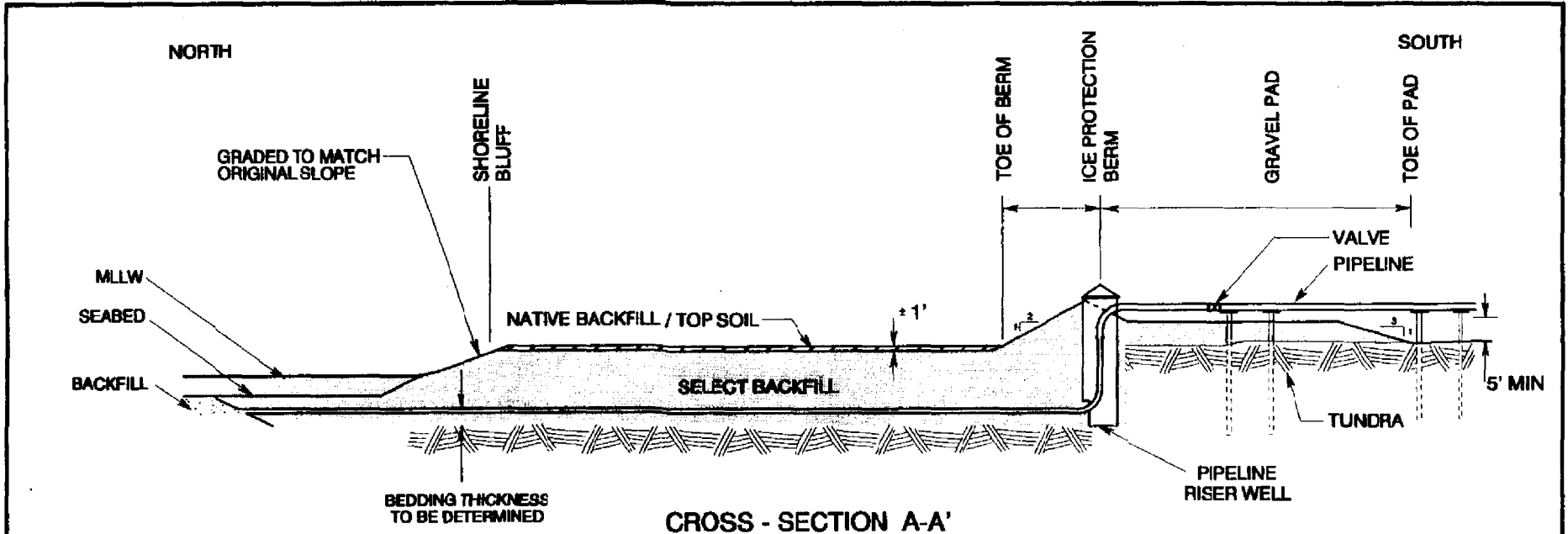

ALL DIMENSIONS ARE APPROXIMATE.
 LOCATION OF VALVES TO BE
 DETERMINED DURING DETAILED DESIGN.

| | | |
|--|------------------------|----------------|
| BP EXPLORATION (ALASKA) INC. | | |
| LIBERTY DEVELOPMENT PROJECT LANDFALL VALVE PAD CROSS - SECTIONS | | |
| DATE: Rev. April 2000 | SCALE: NOT TO SCALE | FIGURE: B-6 |

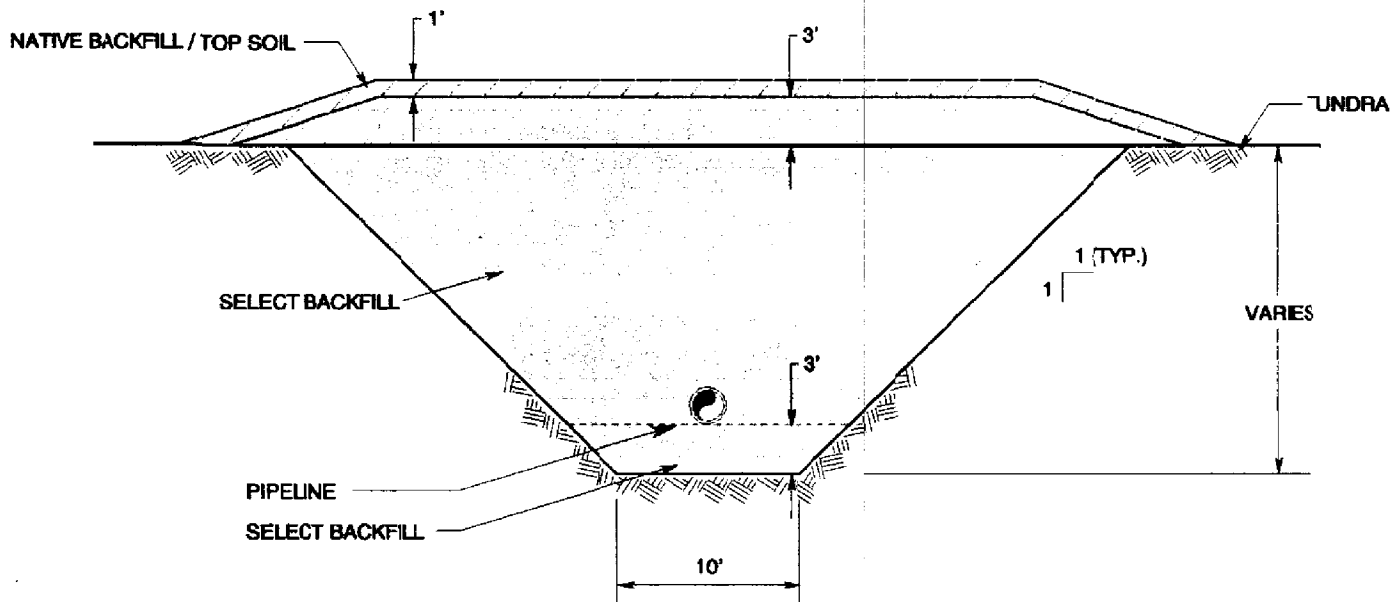

ALL DIMENSIONS ARE APPROXIMATE

BP EXPLORATION (ALASKA) INC.

**LIBERTY DEVELOPMENT PROJECT
TYPICAL ONSHORE PIPELINE TRANSITION
BACKFILLED TRENCH SECTION**

| | | |
|--------------------------|---------------|----------------|
| DATE: Rev. April 2000 | SCALE: N/A | FIGURE: 8-7 |
|--------------------------|---------------|----------------|

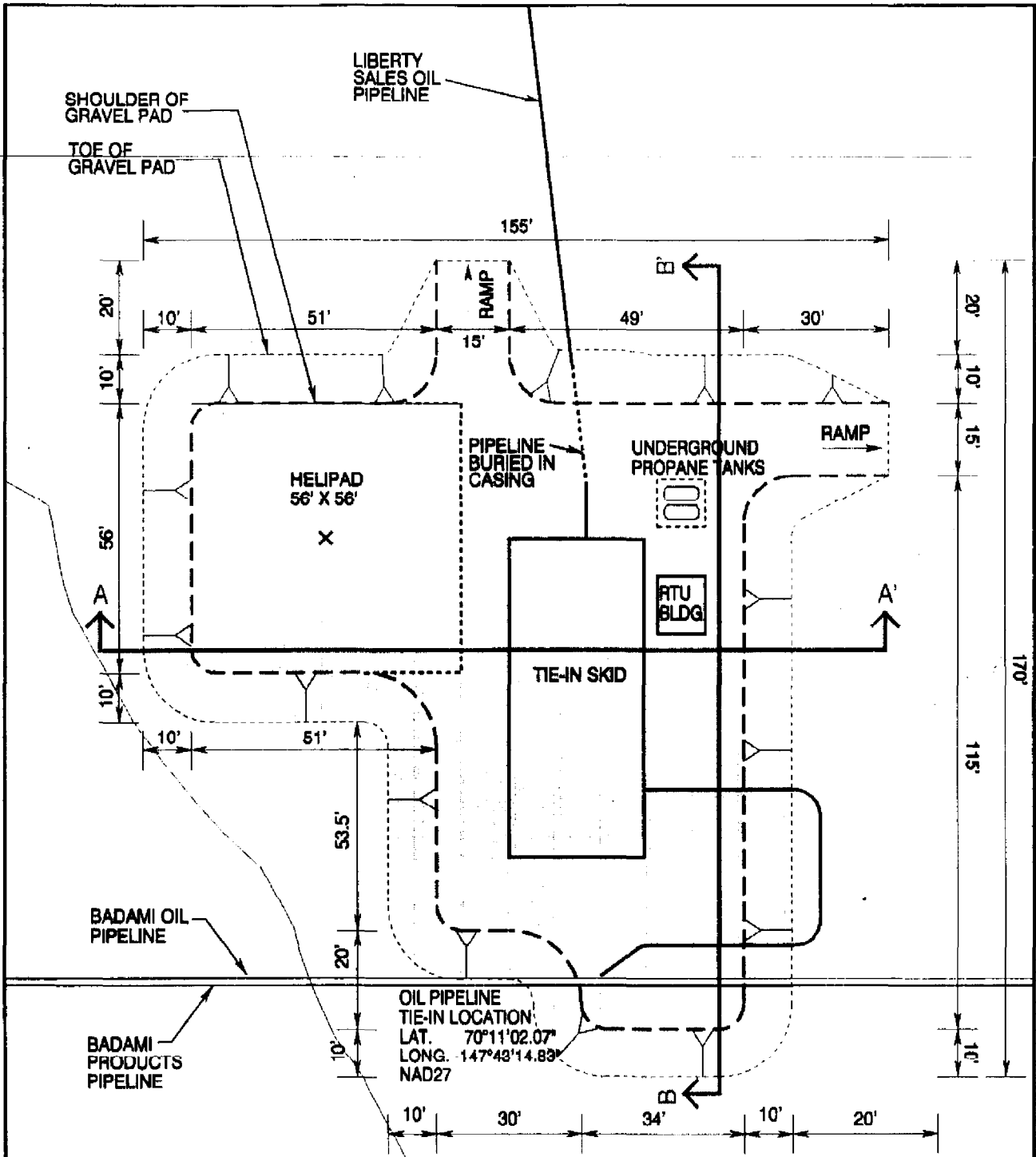

X PAD CENTROID
LAT. 70°11'03.1287"
LONG. -147°43'14.8048"
NAD27

ALL DIMENSIONS ARE APPROXIMATE.
DIMENSIONS AND LOCATIONS OF
FACILITIES TO BE DETERMINED
DURING DETAILED DESIGN.



BP EXPLORATION (ALASKA) INC.

**LIBERTY DEVELOPMENT PROJECT
BADAMI TIE-IN PAD
PLAN VIEW**

| | | |
|--------------------------|------------------------|----------------|
| DATE: Rev. April 2000 | SCALE: NOT TO SCALE | FIGURE: 8 8 |
|--------------------------|------------------------|----------------|

WEST

EAST

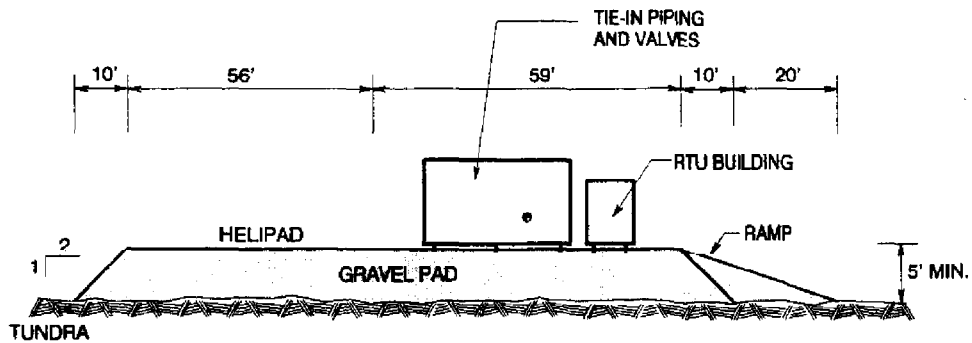

SECTION A - A'

SOUTH

NORTH

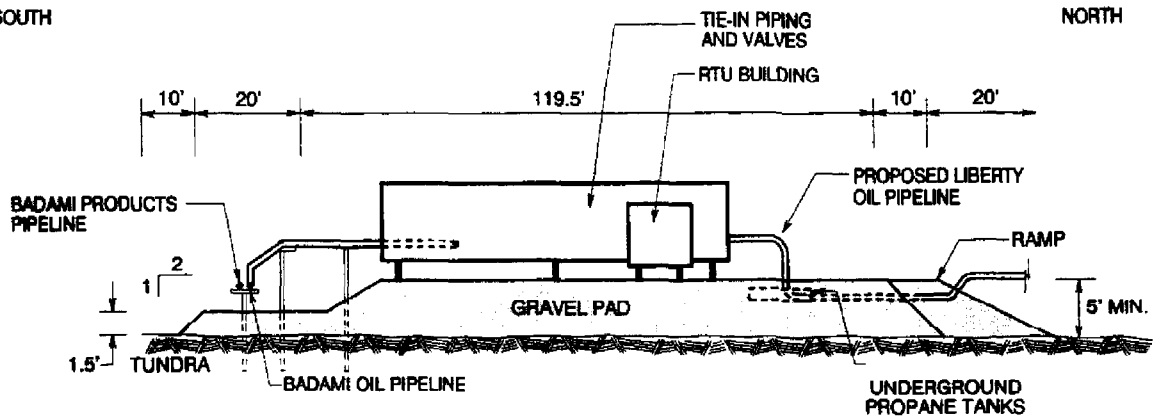

SECTION B - B'

BP EXPLORATION (ALASKA) INC.

LIBERTY DEVELOPMENT PROJECT
TIE-IN PAD
CROSS SECTIONS

ALL DIMENSIONS ARE APPROXIMATE

DATE:
Rev. April 2000

SCALE:
NOT TO SCALE

FIGURE:
8-9

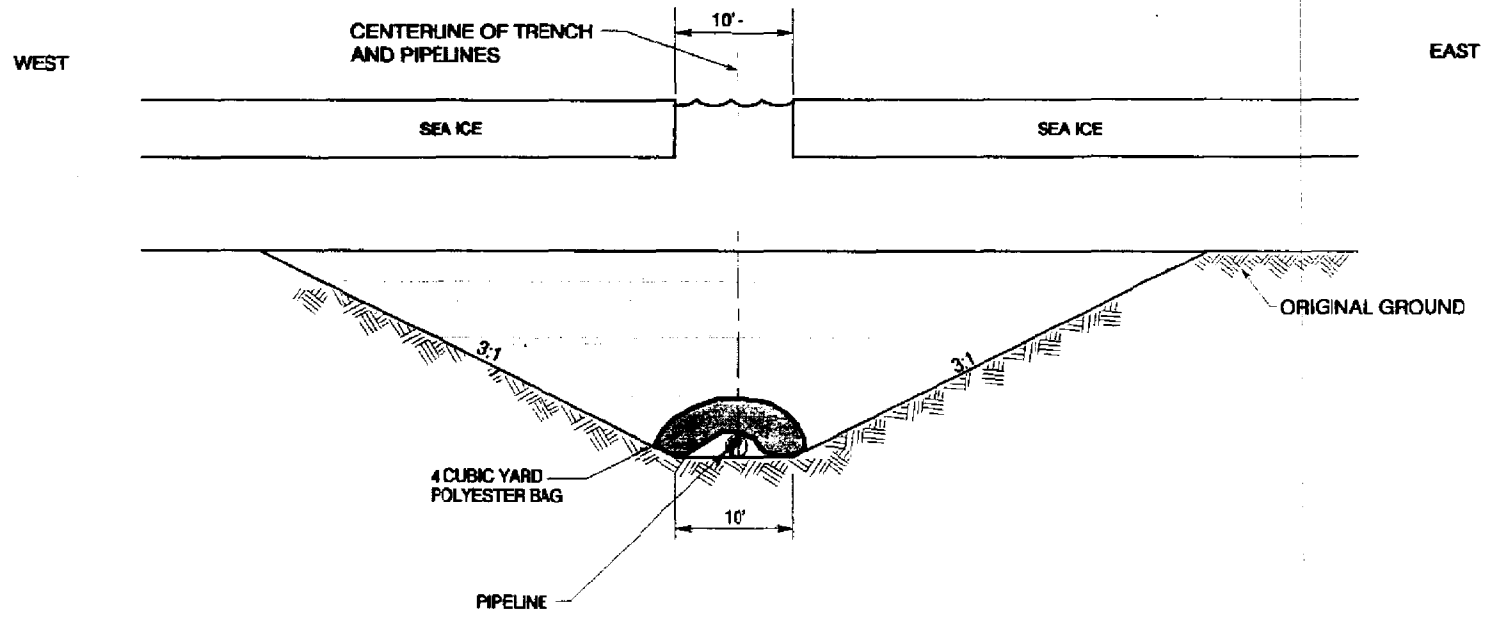

NOTES:

1. PIPELINE DEPTH OF COVER IS 7 FEET MINIMUM.
2. TRENCH SIDE SLOPES ARE VARIABLE, DEPENDING ON SOIL CONDITIONS.

ALL DIMENSIONS ARE APPROXIMATE

| | | |
|--|---------------|-----------------|
| BP EXPLORATION (ALASKA) INC. | | |
| LIBERTY DEVELOPMENT PROJECT DETAIL OF GRAVEL BAG PLACEMENT OVER PIPELINE | | |
| DATE: Rev. April 2000 | SCALE: N/A | FIGURE: 8-10 |

9. INFRASTRUCTURE AND SUPPORT FACILITIES

This section describes support utilities and infrastructure associated with production and pipeline operations, as well as onshore and offshore facilities to be developed or used directly in support of this project.

9.1 UTILITIES AND INFRASTRUCTURE

9.1.1 Seawater Inlet Facilities

Seawater will be drawn through the seawater intake sump, primarily to provide seawater for the Seawater Treatment Plant (STP) (approximately 75,000 barrels per day). Other uses include potable water, drilling, and firewater (normally no flow). Seawater for the STP, potable water, and drilling will be chlorinated immediately downstream of the seawater lift pumps to a target concentration of approximately 0.1 part per million (ppm) chlorine. The firewater pump will take seawater directly from the sump without chlorination. Brine from the potable water treatment process will be discharged to the sea under an NPDES permit.

9.1.2 Infrastructure

Permanent Living Quarters / Utility Module

The PLQ / utility module will provide life support for personnel on the island, including standby power generation, potable water, sewage treatment, living accommodations, medic room, and offices. The PLQ will be of modular construction, will have a minimum footprint on the island, and will be closely linked to the utility module. The wood frame three story structure will be sized for a combined operations and drilling crew of 75 people. After the infrastructure sealift and hook-up, up to 134 people could be housed in the PLQ on a temporary basis. The utility module will contain the following:

- Standby diesel generators with 3,000 barrel adjacent storage tank
- Switchgear and transformers
- Potable water system with 2,100 barrel adjacent storage tank
- Domestic wastewater treatment facility
- Incinerator and trash compactor
- Laboratory

Warehouse/Shop

The building housing the warehouse and shop facilities will be a pre-engineered steel frame building designed for maintenance, welding, storage, hazardous material storage, and

safety briefings. A mezzanine level may be incorporated to meet space requirements and to keep the building footprint to a minimum.

The firewater pump will be located in the seawater intake sump inside the warehouse. There will be no discharges associated with the seawater intake sump. The firewater system will be tested annually with the firewater discharged to the sea (note that the firewater pump will be tested more frequently with the discharge recycled to the sump).

Helipad

A helicopter pad will be located on the island, and will meet appropriate FAA and USCG guidelines. Exterior floodlights will be provided for passenger off-loading with flush mounted lighting around the perimeter of the helipad. A lighted windsock will be located on the PLQ.

Process Control Room

The process control room will be located in the control module with remote connections to the process area. The control module will be separated from the main process area by a distance of approximately five feet. The control room will not be continuously manned. There will be a fully functional control console located in the process module to allow the operator to respond to or make process changes from either location. Full time fire/gas and process alarm monitoring will be performed from a monitoring station located in the PLQ.

9.1.3 Electrical Power

Power Generation

Early Year 2 construction work will be completed with diesel-fueled mobile equipment. The support infrastructure facilities will be powered by standby diesel generators from late August Year 3 until the main turbine generator is running on fuel gas.

Once the facility is operational, power requirements for drilling of approximately 3,200 kW will be supplied by high-line power. Drilling will be supplied with standby power of 850 kW from the utility module emergency diesel generators. The utility electrical loads will be shed as required to provide drilling their essential power requirements. Early drilling (before plant commissioning) will be powered by diesel generators.

Once all production facilities are installed and operational, the base load power requirements, excluding drilling, will be approximately 21,700 kilowatts (kW). This electrical load requirement will be provided by one 100 percent gas fired turbine generator (no spare). Essential power will be provided by two nominal 2,000 kW diesel generators. These units will be installed with the infrastructure.

Essential Power

Two diesel generators will be required to supply power for the majority of the essential power situations. A 3,000 barrel diesel storage tank will be located permanently on the island.

The two standby generators are diesel fueled units rated for 2,600 kW each. These generators and associated switchgear will be installed and commissioned soon after completion of the island, and will supply the PLQ / utility module, and the grind and inject facility. In the event of only one generator being available, a loadshed system will reduce load to the capability of one generator. Loads which may become necessary during an extended outage can be manually repowered; the system operator will be required to ensure the total load on the standby system does not become excessive. If the load from the essential system falls below the generating capability of one machine (e.g. low heating requirements), the system controls will shutdown one unit automatically.

The diesel generators will provide power for infrastructure, drilling, and grind and inject facility until commissioning of the main power turbine generators. Ultimately, the essential power will be tied to the main power system at the distribution voltage. Automatic start capability will provide power to standby loads within the PLQ, utility module, warehouse, grind and inject facility, and process/compression/STP modules. Diesel supply for permanent operations will be delivered by barge in the open water season (estimate of two trips per season), and possibly by ice road in the winter (estimate of two trips per season).

Critical and life safety loads will be supplied by an uninterruptable power supply. Standby loads will include priority heating, lighting, ventilation, heat trace, turbine starting motors, and controls. The firewater pump will be a self-contained diesel unit.

Electrical Design Basis

The enclosed area of the process module and buildings containing production equipment will be designed as Class I Division II. All control and control module/switchgear buildings will be designed as non-hazardous. Normal air changes are provided by the heating, ventilation, and air conditioning (HVAC) system. Additional exhaust fans, under emergency gas-leak conditions, will ensure the minimum explosive limits of 20 percent of the LEL will not be reached during normal operation.

The HVAC system will maintain a minimum temperature of 40°F in all process buildings. Electrical heaters in the control room and the control module buildings are connected to the essential electrical bus. Heating for the environmentally controlled area of the process module and the pump house will be provided by utilizing the heat media (monoethylene glycol or equivalent) system. All ventilation and exhaust fans are connected to the essential electrical bus. Ten percent of all lighting fixtures in the process area will be connected to the essential lighting transformer. All lighting in the quarters, office, and warehouse will also be connected to this transformer, as are floodlights on hinged poles which provide outside lighting.

9.2 SUPPORT FACILITIES

In addition to the major project components (gravel island, production facilities and infrastructure, and pipeline system), a system of project support facilities will also be required for construction and operation of this project. These include:

- a system of winter ice roads
- a gravel mine site
- onshore freshwater sources

9.2.1 Ice Roads

A system of ice roads will be built to support project construction, as shown on Figure 2-1. The ice roads will extend in a corridor along the coastline from the Endicott Causeway to the shore crossing location at Foggy Island Bay, in a corridor from the island to the Badami Pipeline tie-in to support pipeline construction, in a corridor from Pt. Brower to the island, and from the island to the proposed mine site to support island construction. Additional ice road spurs will be constructed as necessary to interconnect the ice road system, and to access existing permitted water sources. The use of ice roads allows on-ice trench excavation and pipe laying activities, and the bulk hauling of gravel and other materials to the island and pipeline route locations with virtually no impact to the marine or terrestrial environments.

The trunk road built on grounded sea ice and ice roads constructed onshore will have a traveled surface approximately 40 feet wide. Typically, ice roads constructed on the tundra to access water sources will be approximately 6-inches thick, with a traveled surface about 30 feet wide.

The ice road built in support of pipeline construction in the pipeline corridor will be contained within the pipeline construction right-of-way, and will be sufficiently thick to support numerous passes of heavy construction equipment. The ice road connecting the mine site to the island will be about 50 feet wide and approximately 6-inches thick onshore. Offshore, this road will consist of two distinct segments: a section constructed on grounded sea ice, and a floating section. The floating section of the sea ice will be thickened approximately eight feet to support heavy loads required for island construction.

In addition to the ice road system, three ice pads are also planned to support construction. These include the pipe stringing and two stockpile/disposal areas needed for pipeline construction (see Section 8). During the winters when production well drilling is occurring, an additional storage area of approximately 350 by 700 feet will be built on the sea ice on the east side of the island. This site would be used to store tubulars and other clean materials.

Ice roads will be constructed by using snow cover and water to form an initial trail. Snow fences may be required to gather snow. Ice thickness will be increased by spraying additional water until the road is the desired thickness (about 6 inches onshore). Additional water will be added as necessary for road maintenance. Construction will be scheduled to begin as soon as conditions are appropriate. The ice roads and pads will thaw in the summer season.

In subsequent years, an ice road system will be constructed to access the island. The location of the coastal trunk road will remain essentially the same from year to year. The ice road segment from the trunk road from the island will be located in the same general corridor as the road built to support pipeline operations or as the road from Pt. Brower to the island; the

location will be adjusted as necessary each year to accommodate existing offshore ice conditions.

9.2.2 Gravel Sources

Approximately 865,000 cubic yards of gravel will be required for island construction, for the pipeline landfall valve pad, for pipeline trench select backfill, and for the tie-in with the Badami pipeline. In addition, it is estimated that approximately 125,000 cubic yards of gravel would be required to construct an island from which to drill an emergency relief well, if one is ever required. Thus, a source of approximately 990,000 cubic yards of gravel is required to meet immediate and potential long term project needs.

The preferred source of gravel is a new mine site, developed specifically for this project, in the Kadleroshilik River flood plain. The plan would be similar to that for other recent mine sites developed on the North Slope, including the East Badami Mine Site, the proposed Northstar mine site in the Kuparuk River and the Kuparuk Dead Arm Mine Site. The general approach of these mining and reclamation plans is to minimize the effects of mining and to create conditions that improve fish habitat. The detailed Liberty Mining and Reclamation Plan was developed in coordination with the state and federal agencies, and will meet Alaska Department of Fish and Game criteria for mine site development.

An onshore gravel mine will be developed to meet project gravel requirements for construction of the island, select pipeline trench backfill material, the pipeline landfall pad, and the Badami pipeline tie-in pad. The mine will be developed in two phases, to support the two year construction schedule. As a contingency, the mine site also contains a reserve area with sufficient gravel resources for construction of a separate, smaller island for the drilling of an emergency relief well, if ever necessary for emergency response requirements.

The mine site (Exhibit A) lies approximately 1.4 miles south of Foggy Island Bay on a partially vegetated gravel island in the Kadleroshilik floodplain. The ground surface elevation of this island is approximately six to ten feet above MSL. The development mine site is approximately 31 acres in size, with the primary excavation area developed as two cells. One cell will be developed each winter construction season. The Phase 1 cell will be approximately 19 acres to support gravel island construction, and the Phase 2 cell will be approximately 12 acres to support pipeline construction, for a total disturbed area of approximately 31 acres. The planned reserve area is approximately 22 acres, for a total planning mine site size of approximately 53 acres.

The gravel mining and rehabilitation plan was developed with the objective of minimizing environmental impacts through mitigation features incorporated into the project design. Each mine cell will be developed, gravel extracted, and site rehabilitation initiated within a single winter construction system.

Mining is scheduled to begin in January Year 2. Unusable material will be stripped from the site and stockpiled in a designated reserve area. Gravel will be removed in two 20 foot lifts. After useable gravel has been removed from the mine, materials unsuitable for construction (e.g.

unusable materials stockpiled during mining) will be placed in the mine excavation. These backfilled materials will be used to contour one side of the cell and create a shallow shelf area to improve future habitat potential of the site.

After mining the Phase 1 cell is complete, the mined site will be connected to the active channel of the Kadleroshilik River. During spring breakup, the mine site will flood with fresh water, forming a deep lake adjacent to the river. Over time, coastal storm surges flooding into the mine site may create brackish water conditions.

The Phase 2 cell will be developed in a similar manner, except that the berm separating the two mine cells will be breached, expanding the original flooded site to create a larger lake. The breached berm should turn evolve into a series of islands in the new deep water lake. Backfill (e.g. materials stockpiled during Phase 2 mining and excess material from onshore pipeline trench construction) will be used to enhance the shallow shelf area created in the Phase 1 cell to improve future habitat potential of the site.

Upon rehabilitation, the flooded mine site will provide several benefits. Deep water sources connected to streams and rivers are uncommon in this area. The excavation will create potential overwintering habitat for fish in an area where this type of habitat is limited. BPXA is planning to use backfill to create shallow water habitats in conjunction with flooding the mine site for rehabilitation. The pit may also provide a source of water for offshore ice road construction (if brackish water is present the source cannot be used to construct onshore ice roads).

9.2.3 Construction Camp/Support

Construction during the period from December Year 1 to summer Year 3 will be staged from existing or on-site facilities. BPXA plans to house the majority of the summer work force in existing onshore facilities until the infrastructure sealift. After installation of the infrastructure modules, the permanent living quarters will be ready for occupancy. An additional temporary camp housing up to 125 workers may also be installed during the summer of Year 2; sanitary and domestic wastewater from this camp would be discharged in accordance with the Arctic General NDPEs permit.

As an option, summer Year 3 facility installation, hook-up, and commissioning might be supported from a construction barge camp moored near the island (Figures 9-1 and 9-2). In this case, the camp would probably be in a size range of approximately 150 feet by 380 feet (possibly two connected barges), and would have camp facilities mounted on the barge deck. The camp could house about 200 personnel to support construction and possibly drilling operations. If the barge camp is used, it would be mobilized to the island site in August Year 3. There is some chance that the barge might be over-wintered at the site, and remain there until summer Year 4. The camp would normally be moored adjacent to the island, but might be temporarily relocated occasionally as needed for construction flexibility.

When the camp barge is brought to the island, the barge would be moored to the island dock (if two barges are used they would be moored securely alongside each other). Mooring

lines would be attached as required to ensure a safe and secure facility. A gangway would allow access between the barge and the island.

Approximately 50,000 gallons of diesel fuel would be stored on the barge as fuel for the camp according to U.S. Coast Guard regulations (33 CFR Subpart C) and best industry standards. Wastewater from the camp barge will be treated on board, and discharged in accordance with federal regulations. Camp solid waste will probably be hauled back to the Prudhoe Bay area for recycling, treatment, or disposal in existing approved facilities.

Temporary diesel storage capacity will be required on the island to support drilling and construction. Temporary tank storage would be mobilized to the site over the ice road after island construction and filled by truck just before breakup. Once facilities modules are installed and operational, this temporary storage capacity will no longer be needed. An estimated maximum of 21,000 barrels of temporary diesel storage will be required, and the largest single tank volume would be 5,000 barrels. Tanks will meet all relevant industry, ADEC, and MMS requirements for leak prevention and secondary containment.

Diesel will need to be delivered to the site as needed to maintain the supply needed to support construction and drilling. A maximum of seven deliveries are estimated (one by trucks in winter Year 2, two by barge in summer Year 2, two by trucks in winter Year 3, and two by barge in summer Year 3). Temporary diesel storage will no longer be required after the facilities plant begins operating.

9.2.4 Water Sources

As shown on Exhibit A, existing permitted water sources will be used for ice road construction and other water needs. These sources include existing and abandoned gravel mine sites, as well as several tundra lakes and ponds. It is estimated that the total quantity of freshwater required for project construction is approximately 120 million gallons. During operations, an estimated 20 million gallons would be needed for ice road construction.

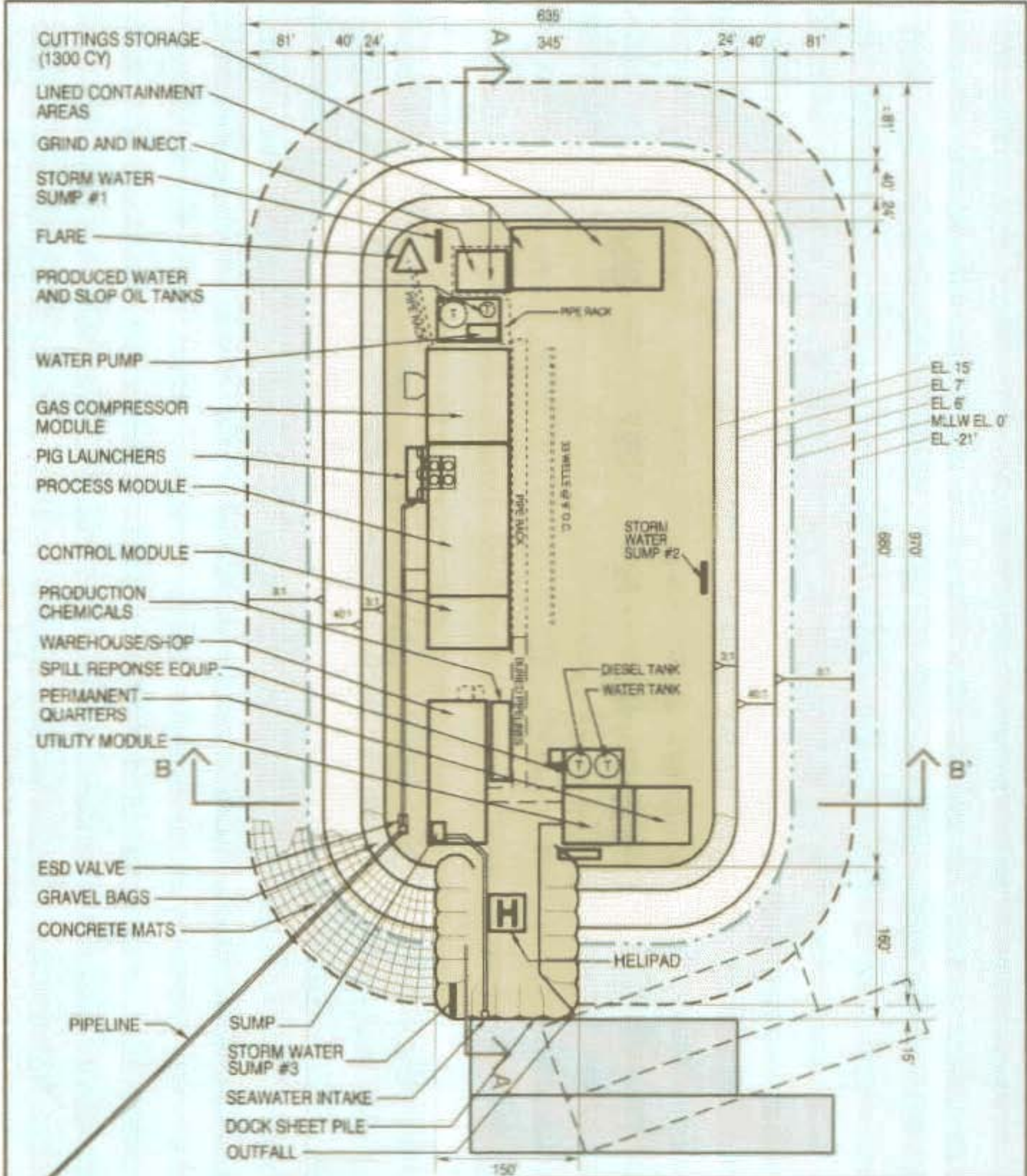

BP EXPLORATION (ALASKA) INC.
LIBERTY DEVELOPMENT PROJECT
ISLAND LAYOUT
WITH CONSTRUCTION CAMP
(OPTIONAL CONFIGURATION)

| | | |
|--------------------------|------------------------|----------------|
| DATE: Rev, April 2000 | SCALE: NOT TO SCALE | FIGURE: 9-1 |
|--------------------------|------------------------|----------------|

PREFERRED POSITION
 ALTERNATIVE POSITION

ALL DIMENSIONS ARE APPROXIMATE

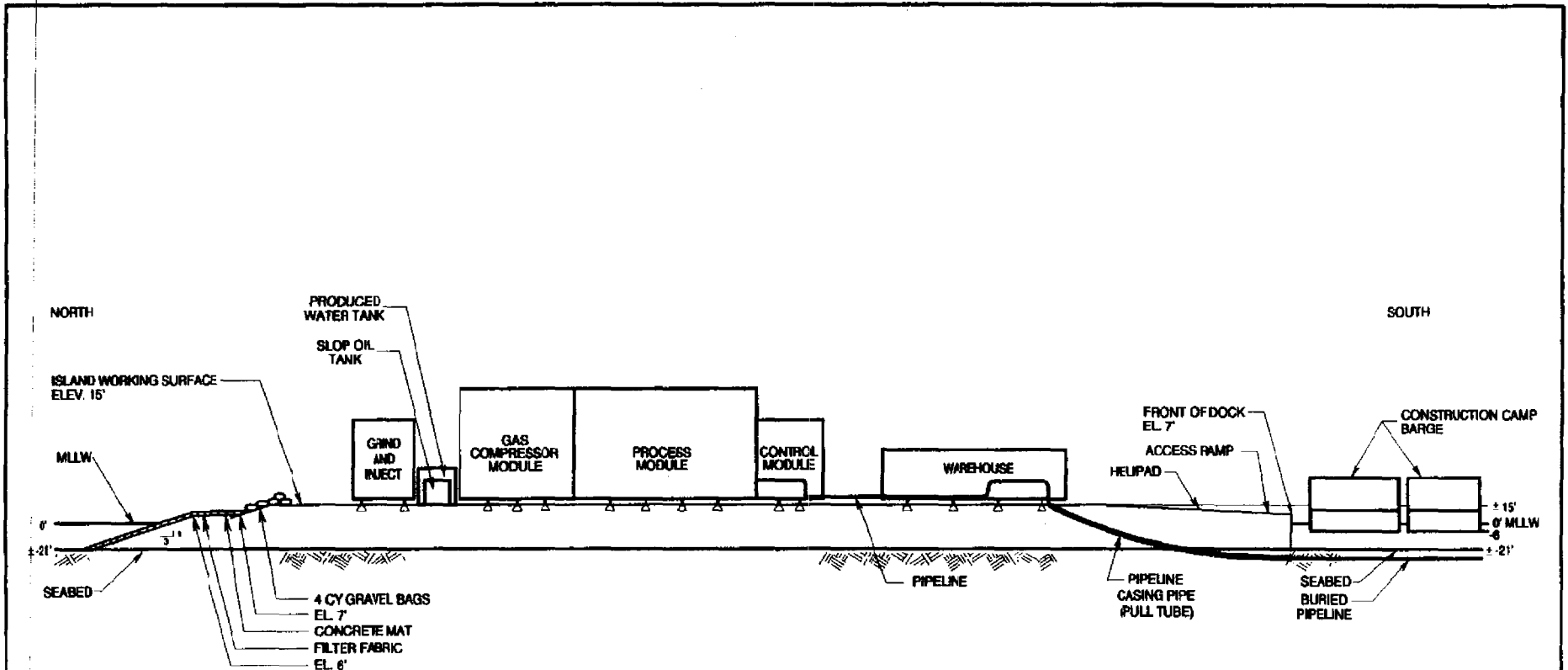

CROSS - SECTION A-A'

BP EXPLORATION (ALASKA) INC.

LIBERTY DEVELOPMENT PROJECT
 ISLAND
 CROSS SECTION A-A'
 WITH CONSTRUCTION CAMP
 (OPTIONAL CONFIGURATION)

DATE:
 Rev. April 2000

SCALE:
 N/A

FIGURE:
 9-2

ALL DIMENSIONS ARE APPROXIMATE

10. DESIGN REVIEW AND ASSURANCE PROCESSES

In addition to approval of this Development and Production Plan, there are several detailed design review processes that must be completed before BPXA can begin project construction. These include MMS and State of Alaska review and approval of pipeline design; MMS review and approval of the island structural design through the Certified Verification Agent process; and various MMS approvals for drilling and safety systems design and installation features.

10.1 PIPELINE DESIGN REVIEW

Both the MMS and the Alaska State Pipeline Coordinator's Office (SPCO) must review pipeline right-of-way applications and issue a lease before pipeline construction. Under the terms of an agreement between MMS and SPCO, it is planned that SPCO will complete design review to assure compliance with both state and federal pipeline design and operating standards.

The State has very broad statutory authority and scope of review over applications for rights-of-way. In making a decision to issue a lease, the Commissioner of Natural Resources must consider whether or not:

- the proposed use of the right-of-way would unreasonably conflict with existing uses of the land involving a superior public interest
- the applicant has the technical and financial capability to protect state and private property interests; and
- the applicant has the technical and financial capability to take action to the extent reasonably practical to:
 - prevent any significant adverse environmental impact, including but not limited to, erosion of the surface of the land and damage to fish and wildlife and their habitat
 - undertake any necessary restoration or revegetation
 - protect the interests of individuals living in the general area of the right-of-way who rely on fish, wildlife, and biotic resources of the area for subsistence purposes
- the applicant has the financial capability to pay reasonably foreseeable damages for claims arising from the construction, operation, maintenance, or termination of the pipeline; and
- the applicant has agreed that in the construction and operation of the pipeline the applicant will comply with, and require contractors and their subcontractors to comply with, applicable and valid laws and regulations regarding the hiring of residents of the state.

As part of its decision process, the SPCO will conduct an extensive review of the application to assure the technical integrity of the design. As part of this review, SPCO will likely evaluate structural and mechanical design, proposed leak prevention and detection methods, geotechnical information, ice gouge potential, strudel scour potential, adequacy of the proposed quality assurance program, pipeline operations procedures, monitoring and surveillance, and other factors affecting the overall technical performance of the pipeline system. SPCO will probably require assistance through third party reviewers for certain aspects of the technical review. BPXA submitted an initial pipeline design basis document to SPCO for review in March 1998; this document supplements information provided in the August 8, 1997 application. In addition, the Liberty Quality Assurance Plan has been approved. A Construction Plan must be reviewed and approved before construction may begin, and a Surveillance and Monitoring Plan must be reviewed and approved before pipeline operation begins.

MMS will also require submission of detailed pipeline design information for review and approval prior to construction. The design basis document to be provided to SPCO will provide the basis for the MMS detailed pipeline application.

10.2 ISLAND DESIGN REVIEW

Island structural design must be reviewed and approved by the MMS prior to construction through the third party Certified Verification Agent (CVA) process. Under this process, BPXA will prepare and submit an Island Design Plan to the MMS. An independent third party CVA will then review the gravel island and slope protection design to assure integrity over the life of the project, including:

- wave heights and periods
- currents
- winds
- water depth
- tide data
- storm surge
- ice effects
- air and sea temperatures
- geotechnical conditions
- loadings
- soil stability
- seafloor survey results (shallow hazards surveys)
- design life
- design loadings
- material specifications

10.3 OTHER MMS REVIEWS

In addition to the major MMS DPP, pipeline and design approvals, numerous other major and minor authorizations are required before drilling and/or construction can commence. These are summarized in Table 10-1.

Table 10-1

MMS Review and Approval Authorities

| REGULATORY AUTHORITY (30 CFR PART 250:) | DESCRIPTION |
|--|---|
| 250.204 | Development and Production Plan (this document) |
| 250.301(b)(2) | Approval of the method of disposal of drill cuttings |
| 250.401 (a)(3) | Fitness of drilling unit |
| 250.402 (b) | Welding, burning, and hot tapping plan. |
| 250.414 | Application for Permit to Drill (includes detailed safety and operational information) |
| 250.415 | Sundry Notices (minor changes in drilling plans) |
| 250.417 (h) (1) | Hydrogen sulfide contingency plan |
| 250.513 | Well completion |
| 250.613 | Well workovers |
| 250.802 (e) | Safety-systems design and installation features (requires detailed design review of process facilities) |
| 250.803(b)(8) | Fire fighting system |
| 250.901 | Applications for approval of platform (CVA design review process described in Section 10.2) |
| 250.909 | Foundation (soils investigations; site investigation; including shallow hazards and geological surveys) |
| 250.1007 and .1010 | Application for approval of pipeline right-of-way grant: (described in Section 10.1) |
| 250.1102 (b) (2) | Oil and gas production rates |
| 250.1105 (c) | Bottomhole pressure survey. |
| 250.1107 | Enhanced oil and gas recovery operations |
| 250.1200 (b) | Measurement of liquid hydrocarbons |
| 250.1201(b) | Gas production |
| 250.1501 | Application for approval of training program |
| 250.1503(f) | Submission of training programs for well completion, well work-overs and well control |
| 250.1504(d) | Submission of training programs for production safety systems course |

11. EMPLOYMENT

The Liberty Development Project is expected to generate approximately 300 construction jobs, 100 drilling jobs, and 50 maintenance/operational jobs. BPXA has a policy of preferring to hire Alaskan workers and contracting with Alaskan firms, so most of this work will be expected to generate economic multiplier effects within Alaska.

Island construction, pipeline construction, final fabrication of facilities, and drilling and processing will take place on-site on the North Slope. Project engineering personnel are currently located primarily in Anchorage and in Houston, Texas. Anchorage will be the site of most module and other material fabrication, and mobilization of the sealift to the North Slope work site. Pipe fabrication and insulation could take place in Fairbanks.

Construction will generally be conducted with one shift present at the work site and one out on break. Given the shift nature of North Slope activities no permanent population increase in the nearshore area is expected to result from the Liberty development.

Drilling is scheduled to be a continuous operation lasting for about two years. Two crews will be on the island at any time, serving 12 hour shifts. Crews will be shifted in and out on a 14-day basis. Thus, approximately 25 workers will be drilling at any given time and each drilling position will employ four full-time workers. The initial development drilling phase is anticipated to have a duration of approximately 19 months.

Once production starts, one operations crew will be on the island at any time, with one out on break. The majority of the operations personnel on the island will work day shift, with a minimal operating staff on the night shift. The operations crews will be required for the lifetime of the field, currently estimated to be approximately 15 years.

Direct economic effects from the Liberty development (job creation, increased revenue flow) will take place mostly on the North Slope and in southcentral Alaska. Liberty's relatively small size in relation to existing North Slope fields will not result in any significant increase in demand on local (i.e. Alaskan) contractor or vendor services aside from the initial construction phase outlined above.

BPXA has made a commitment to hire local workers on the North Slope and within Alaska. In a partnership with Arctic Slope Regional Corporation (ASRC), the Alaska Native corporation for the Arctic Slope region, BPXA has begun the Itqanaiyaqvik Employment and Training Initiative aimed at helping ASRC shareholders and other residents of the North Slope Borough prepare for oil and gas employment opportunities. New projects like Liberty will require operations staff, drilling, maintenance and other support staff — graduates from these training programs will be candidates for these positions with BPXA or subsidiaries of Arctic Slope Regional Corporation, such as Alaska Petroleum Contractors and Houston Pipeline Company, who will be involved in Liberty construction and operations.

BPXA has made a commitment to hire local workers on the North Slope and within Alaska. In a partnership with Arctic Slope Regional Corporation (ASRC), the Alaska Native corporation for the Arctic Slope region, BPXA has begun the Itqanaiyaqvik Employment and Training Initiative aimed at helping ASRC shareholders and other residents of the North Slope Borough prepare for oil and gas employment opportunities. New projects like Liberty will require operations staff, drilling, maintenance and other support staff - graduates from these training programs will be candidates for these positions with BPXA or subsidiaries of Arctic Slope Regional Corporation, such as Alaska Petroleum Contractors and Houston Pipeline Company, who will be involved in Liberty construction and operations.

The first two phases of this initiative are underway; these involve an adult "job shadowing" program; and the ALVA (Alliances of Learning and Vision for Under Represented Americans) program with the University of Alaska aimed at preparing selected candidates for technical or engineering professional degree programs. Both of these programs are built on an earlier high school "job shadowing" program sponsored by BPXA, which involves high school students selected from the North Slope School District visiting the oil fields for professional orientations and "job shadowing" in an area of interest.

As of September, 1998, 23 North Slope residents have been through the "job shadowing" program, with 21 now employed in oil field jobs. Also this summer, seven Native students successfully completed the first ALVA program. The high school job shadowing program is intended to feed candidates into either the university preparatory program or the adult job shadowing program, which is aimed at getting people ready to go to work. Most graduates of the BPXA adult job shadowing program are already working in oil field jobs.

All construction, drilling, and operations work will be conducted in accordance with BPXA worker safety standards and procedures. To ensure that safety objectives are met, BPXA will follow a structured process to identify safety hazards and risks, identify means to avoid hazards and risks, and implement safety procedures, including training and reporting. Advance safety planning and risk assessment are also integrated into the project design process. In addition, work will comply with relevant state and federal worker safety requirements, including Alaska State Department of Safety and Health Construction Code, Alaska State Safety and Health Codes (DOSH), Federal Safety and Health Codes (OSHA), and the MMS Safety and Environmental Management Program.

12. ENVIRONMENTAL SAFEGUARDS

This section outlines measures taken to assure environmental protection, including protection of biological resources, pollution prevention, minimization of discharges and emissions, and management of wastes. The Environmental Report contains a detailed analysis of the affected environment, environmental impacts, and project mitigation.

12.1 HABITAT AND WILDLIFE PROTECTION

The overall Liberty project has been planned and designed to minimize adverse effects to biological resources. In addition, the project incorporates mitigation measures to offset impacts from construction and operations.

The island, the pipeline, and excess material disposal sites were sited to avoid impacts to the Boulder Patch. In addition, use of filter fabric underlying the island concrete mat slope protection will minimize post-construction sediment release into the water column. Most civil construction, including pipeline installation, gravel hauling and fill to build the island, and sheet pile driving for dock construction will be completed before the open water season in the first or second construction year, at a time when relatively few wildlife are present and there is less potential for adverse effects. Construction work just prior to and during the open water season the first construction year will include installation of slope protection, construction of foundations, and module delivery. Modules would also be delivered in the second year. Any reworking of the island side slopes would occur before or just after breakup, with the intent of minimizing the scope of activities during the open water season that could result in water quality impacts and associated impacts to the Boulder Patch. These activities are scheduled to occur before the fall whaling season begins.

Implementation of an approved Oil Spill Contingency Plan will effectively limit the potential for adverse impacts to wildlife and habitats as a result of a spill. Also, a comprehensive training program will be implemented to assure that all personnel are appropriately trained in wildlife avoidance and interactions, and fully understand the need for protection of subsistence wildlife resources and for protection of endangered species. In accordance with the requirements of the Marine Mammal Preservation Act, BPXA will seek Incidental Harassment Authorizations and/or Letters of Authorization addressing incidental or small take of marine mammals, including preparation and implementation of a project polar bear interaction plan. BPXA will avoid overflights of Howe Island during Snow Goose nesting and rearing, and will continue to coordinate with the resource agencies to identify any other needed air traffic constraints.

12.2 POLLUTION PREVENTION

Liberty project planning includes pollution and spill prevention measures, as well as spill response preparedness. For the overall project to be authorized, it must meet the requirements of:

- 30 CFR Subpart C - MMS Pollution Prevention and Control
- 30 CFR Part 254 - MMS Oil Spill Contingency Plan requirements
- 18 AAC 75 - State of Alaska Spill Prevention and Response regulations

MMS Pollution Prevention regulations require the lessee to take measures to “prevent unauthorized discharge of pollutants into offshore waters”, and require the lessee to “not create conditions that will pose unreasonable risk to public health, life, property, aquatic life, wildlife, recreation, navigation, commercial fishing, or other uses of the ocean”. These regulations also require that “all hydrocarbon-handling equipment for testing and production such as separators, tanks, and treaties will be designed, installed, and operated to prevent pollution; and that “maintenance or repairs which are necessary to prevent pollution of offshore waters ... be undertaken immediately”. These regulations also include requirements for secondary containment and control of surficial drainage.

The proposed project has incorporated design measures to assure that the potential for spills and leaks has been minimized to the extent practicable. These features include:

- island grading plan - surface drainage controlled by flowing to sumps with oil/water separators to handle minor spills (Figure 12-1)
- storage tanks and process facilities located in lined, bermed areas
- pipeline leak detection systems
- pipeline valving plan
- well control design

In addition to spill and leak prevention measures incorporated in design and operations planning, BPXA must develop an approved Oil Spill Contingency Plan (OSCP) addressing activities in federal waters, as well as an Oil Discharge Prevention and Contingency Plan (ODPCP) for activities in state waters and lands. These plans require identification of spill prevention measures, including use of Best Available Technology. The plans also require demonstration of the ability to identify, respond, and cleanup spills with the appropriate equipment in all conditions expected at the site, including open water conditions, broken ice conditions, and frozen conditions.

The spill plan for this project has been developed in coordination with a North Slope-wide effort. This planning effort involved all relevant local, state, and federal agencies with the goal of developing a set of scenarios and associated responses to assure that North Slope operators can respond to spills. Liberty spill planning considered this Slope-wide information, adjusting as necessary to reflect site specific conditions.

12.3 DISCHARGES AND EMISSIONS

A major goal of Liberty project planning has been to minimize waste generation, minimize air emissions (both regulated pollutants and greenhouse gasses), and have zero surface discharges of drilling wastes. As described in Section 12.4, most waste streams will either be disposed of in the waste injection well or backhauled to existing onshore injection facilities.

Project operation will result in several discharges. BPXA has submitted an application for an Individual NPDES Permit for the following discharges: seawater treatment plant backwash; reverse osmosis unit filter backwash; construction dewatering; sanitary/domestic wastewater; and fire test water. The application for the NPDES permit contains detailed information about the quantity and nature of these discharges.

The project will generate air emissions from operation of construction equipment, including marine vessels, from drilling activities, and from operations. Emission sources are inventoried and effects of the project on air quality are detailed in the application for Part 55 Air Quality Permit submitted to the U.S. Environmental Protection Agency. A supplement to the application lists associated emission sources (including composition, frequency, and duration of emissions) on State of Alaska lands and waters. These include temporary construction sources (concrete manufacturing, gravel mine operations, and pipeline construction), as well as permanent sources (power generation equipment at the shore transition pad, and power generation equipment and a heater at the tie-in pad).

In accordance with BPXA corporate policy, the project has incorporated measures to reduce "greenhouse gas" emissions (see Section 6.2.1).

12.4 WASTE MANAGEMENT

The waste management strategy developed for the Liberty Project consists of waste minimization to the greatest extent possible coupled with on-site disposal, primarily in an injection well (see Appendix A), wherever practical. The design considerations associated with implementing this strategy include physical access to the site, on-site storage capability, and regulatory compliance.

Site access varies according to time of year, and limits the ability to haul waste off site during certain portions of the year. Surface access in winter will be via an ice road; access in summer will be by vessel. During both of these times of year, hauling of waste off site is possible, but not necessarily the most cost effective option. In the spring and fall (breakup and freezeup), access to the island will be limited to helicopter transportation. During these times, waste which cannot be managed on-site may have to be stored for transportation to other disposal facilities during the summer and winter travel periods. Due to the relatively small size of the island, on-site storage of waste material will be limited. Therefore, advance planning and on-site disposal options are incorporated in this waste management strategy to the fullest extent practical.

The following sections discuss disposal strategies for each project phase (construction, drilling, and production operations), and identify management options for specific types of wastes expected to be generated during the project.

12.4.1 Strategies by Project Phase

Construction

No on-site waste management infrastructure will be available until infrastructure modules are delivered in the summer of Year 2. Winter island and pipeline construction operations will be supported by ice roads and existing North Slope gravel roads. Solid wastes generated during the initial construction stages of the project will be back hauled to existing approved facilities for recycling, storage, treatment, and disposal. Solid wastes generated during open water island construction activities will be consolidated on-site and transported to shore and managed at approved facilities, or stored on-site until access is available. Portable restroom facilities will be located at the construction sites; and wastewater will be emptied and hauled away or the units exchanged regularly. Wastewater will be handled at an existing North Slope facility. Waste handling from the possible camp barge is described in Section 9.

Drilling

Drilling will commence after island infrastructure has been installed. The first well to be drilled will be the waste injection disposal well. At this stage of the project, other waste management facilities will be available for use, including a solid waste incinerator and a sanitary/domestic wastewater treatment system and grind and inject facility. Due to island space limitations, on-site processing and facilities for drilling waste disposal will be used to the maximum possible extent. These will include tanks for temporary storage of drilling wastes, a cuttings grind and inject facility, a waste injection well, and annular injection.

Production Operations

Again, due to space limitations, on-site disposal options will be used to the fullest possible extent. On-site disposal options include a sanitary/domestic wastewater treatment facility, a waste disposal well, a grind and inject facility, and an incinerator. Waste material that must be transported off the island for disposal will be transported by vehicles using ice roads during the winter months and vessels during the summer open water period. During breakup, this material will be stored until transport options are available or carried to shore using alternative means of transportation, such as helicopters. Production wastes will be injected, or stored and hauled off-site. Solid wastes will be incinerated or hauled off-site. Sanitary and domestic wastewater will be treated and injected, or, as a contingency, treated and discharged.

12.4.2 Management Options by Waste Stream

Non-Hazardous Solid Waste

Non-hazardous solid waste consisting of trash, food wastes, wood debris, metal debris and construction debris will be segregated into burnables, non-burnables and recyclable scrap, and stored in designated containers. Burnables will be incinerated on Liberty Island or transported to existing North Slope processing facilities. Non-burnables and recyclable scrap will be transported to existing North Slope facilities for processing or disposal.

Oily Trash

Non-hazardous oily trash such as oily pit liners, empty oil and grease containers, and oily debris will be collected and stored on-site in designated lined and labeled dumpsters. The waste will be transported to existing North Slope facilities for processing or disposal.

Oily Solids from Vessels

Oily solids from process tanks, vessels, and lines will be slurried and injected in the disposal well or transported to existing North Slope facilities for management. These types of solids are classified as RCRA-exempt wastes and will not be tested prior to disposal.

Drilling Mud

Drilling muds will be disposed of in the waste disposal well or through annular injection. If neither of these options is available (e.g., for the very first well drilled or in the case of well upset), mud will be stored on-site until disposal is available, or transported to existing North Slope facilities for disposal.

Drill Cuttings

Surface hole drill cuttings will be crushed, ground, and injected as a slurry into the disposal well. Below-surface hole cuttings will be ground and injected as a slurry to the disposal well or into a well annulus. Cuttings may be temporarily stored until disposal options are available.

Non-Hazardous Fluid Wastes

Until the on-site waste disposal well is available, waste fluids determined to be non-hazardous, including certain chemicals, tank rinse, sump fluids, and contaminated snow melt, will be properly transported to existing North Slope facilities for disposal. Temporary on-site storage in portable tanks or tank trucks may be necessary.

After the waste disposal injection well is available, non-hazardous fluids will first be evaluated and reused where possible in the drilling process, and if not reusable, injected into the waste disposal well. All types and volumes of materials injected for disposal will be documented to meet agency reporting requirements.

Recyclable/Reusable Fluids

All fluids determined to be recyclable or reusable materials in accordance with state and federal regulations will be managed as such and not as waste products.

Used oil will be segregated from other materials and stored in containers marked with the words "Used Oil". All used oil will be tested to verify acceptability for recycling and inserted into the crude oil stream at Liberty or other North Slope facilities. Testing may consist of a halogens screen and flash point test. Used oil generated from a known source with known inputs (such as from a turbine within the facility) will be evaluated for recycling based on MSDS information.

All other fluids determined to be potentially reusable will, at a minimum, be visually inspected to verify contents. Suitable materials will be labeled with the container contents and stored until reused. Testing will be conducted on fluids which are found to be questionable. All materials determined to be unsuitable for reuse or recycling will be managed as a waste material and characterized for proper disposal.

Hazardous Waste

All wastes determined to be hazardous in accordance with Resource Conservation and Recovery Act (RCRA) definitions will be managed in accordance with all federal and state requirements. Hazardous waste will be placed in drums or other approved containers for storage. All containers will be marked with the contents, the date generated, and the words "Hazardous Waste". All containers will be temporarily stored in areas with secondary containment and fluid collection capabilities. All hazardous waste will be transported to existing approved treatment, storage, and disposal facilities, most likely located in the lower 48 states, for recycling and/or disposal.

RCRA compliance files will be maintained on-site, including information on waste identification, transportation manifests, and all correspondence with state and federal agencies regarding hazardous waste shipments.

Sanitary and Domestic Wastewater

Sanitary and domestic wastewater generated from operations will be treated and injected into the disposal well. Before the waste disposal well is drilled, or in the event that the disposal well is unavailable for injection, treated effluent will be discharged under an NPDES permit.

Sewage Sludge

Sewage sludge generated from camp operations will either be injected in the waste disposal well or back-hauled to existing North Slope facilities for treatment and disposal.

Incinerator Ash

Incinerator ash generated will be characterized in accordance with RCRA guidelines. Ash determined to be hazardous will be managed as hazardous waste. Ash determined to be non-

hazardous will either be injected in the disposal well, or transported to existing North Slope facilities for processing.

Contaminated Snow

During construction and drilling of the waste disposal well, any contaminated snow would be transported to existing North Slope disposal facilities for melting and disposal. Some contaminated snow might be temporarily stored at the point of generation or at a central location in impermeable containers.

After the injection well has been drilled, contaminated snow may be melted on-site and reused as a fluid in the drilling process or injected into the disposal well. Only non-hazardous melt water will be disposed of in the well. Any snow suspected to have the potential for being designated as hazardous will be segregated and melted in a designated bin to recover material for further handling.

Snow contaminated with gravel, soil, trash, wood, and other debris will be stored on the island and melted by natural or mechanical means. Resulting debris will be recovered and properly disposed of according to its characteristics.

Stormwater

Stormwater will be collected in island sumps and injected into the waste disposal well.

Contaminated Gravel

Contaminated gravel and soil will be managed on-site or at other North Slope facilities. Gravel will be remediated and recovered for pad maintenance or other uses where possible. Any needed storage areas will consist of impermeable containment. Remediation may consist of incineration, washing, grind and inject, or other approved technology.

Naturally Occurring Radioactive Material

Naturally Occurring Radioactive Materials (NORM) may be present in some production facilities and BPXA will implement measures to identify and properly handle NORM materials. Well tubulars and piping will be scanned for NORMs when they are pulled from a well or removed from the process. Piping and tubulars that show indications of NORMs (above established background levels) will be properly stored on the island until it is transported to a North Slope area facility and for batch treatment using equipment designed for NORM removal (high pressure water). The resultant water based slurry will be injected in an approved Class II disposal well.

Special Cases

If the following are generated, they will be managed in accordance with the following procedures.

Empty Drums: Due to waste minimization and limited storage space, drum stock will be kept to a minimum. Empty drums will be stored on-site and back-hauled to existing BPXA North

Slope facilities for flushing, crushing, and processing. Empty drum storage will be in secondary containment if there is any threat residual fluids will be released from the drums or if the physical condition of the drums will result in the contamination of snow or gravel.

Aerosol Cans: Aerosol cans that are completely empty (nothing is heard or felt when shaken) will be placed in the non-burnable dumpster. Non-empty cans will be punctured and the contents collected. Punctured cans will be placed in the non-burnable dumpster and the contents will be characterized for proper disposal. Aerosols will not be emptied into facility sumps.

Lead Acid Batteries: Lead acid batteries will be segregated from waste streams and stored inside until transported to existing North Slope facilities to exchange for new batteries with the supplier. Lead acid batteries that are not standard size (e.g., from heavy equipment) may not be accepted by suppliers for exchange and may have to be transported to recycling facilities in the lower 48 states.

Medical Waste: Medical waste will be stored in containers marked "Medical Waste" and will be sent off site to a regulated medical waste incinerator for disposal.

Fluorescent Light Tubes: Fluorescent light tubes will be collected and sent to recycling facilities in the lower 48 states.

Used Oil Filters: Used oil filters will be punctured and hot drained on-site as generated. The collected oil will be screened for halogens and flash point prior to insertion into the crude stream and the drained filter will be placed in the oily trash dumpster.

Radioactive Waste: All radioactive waste will be characterized for disposal as generated. Common sources of radioactive waste are exit signs and smoke detectors. These materials will be stored in containers with the contents clearly identified until being transported off-site for proper treatment and disposal.

Storm Water Sump #1

Storm Water Sump #2

Storm Water Sump #3

| | |
|---|-------------------|
|  | Surface Grade |
|  | Surface Elevation |
|  | Grade Break |
|  | Drainage Swale |



BP EXPLORATION (ALASKA) INC.

LIBERTY DEVELOPMENT PROJECT
ISLAND GRADING AND DRAINAGE
PLAN

DATE:
September 1998

SCALE:
NOT TO SCALE

FIGURE:
12-1

13. OPERATIONS AND MAINTENANCE

The Liberty production facility design is without redundancy, installed spares or bypass capability. Facilities will be staffed on the basis of minimized core staffing consistent with safe, efficient, environmentally sound operation and minimum costs. This requires a design for simple, reliable and unattended operation wherever possible. The project will be staffed with multi-skilled technicians trained to perform all routine plant operations and maintenance (O&M). Specialized maintenance activities such as major equipment overhauls will be performed by external maintenance contractors or by vendor.

13.1 SAFETY EQUIPMENT

13.1.1 Firefighting Philosophy and Equipment

The basic philosophy for Liberty is to attempt a response to a fire in the incipient stage. Upon detection, the plant will shutdown and depressure. All personnel will evacuate the site. Fire protection will be a deluge or foam type sprinkler system. The system will be designed in accordance with API 14G. The electrical equipment in the control module will be protected with small cabinet carbon dioxide extinguishers. Portable fire fighting facilities in the form of dry powder and foam will be provided as necessary. Manual actuation of any fire water systems will be possible either through the central control system and at strategic locations in the plant and camp. Full time fire/gas and process alarm monitoring will be performed from a monitoring station located in the PLQ.

13.1.2 Fire & Gas Detection, Alarm Action and H&V Philosophy

A Fire and Gas (F&G) system will be provided which monitors the plant and provides status information to the central computer system. The system will also provide for automatic or manual operation of fire protection measures.

Instruments for continuously monitoring for the presence of flammable gas and fire will be installed in areas where there is risk of leakage which could lead to a dangerous escalation. Smoke detection will be installed within buildings as necessary. Detection systems will provide alarm only at key locations. Protective action will be by remote and local manual initiation.

Manual alarm indications will be located at strategic points throughout the facility and a fire protection panel will be programmed in the central computer system, provided with zone indication of detector points. The F&G system will be provided with a secure electrical power supply.

When activated, the fire alarm detection system will signal an alarm and shutdown and blowdown the facility via the BESD. The foam fire suppression system will be manually

activated after visual verification of a fire because there are instances, such as a gas jet fire, where extinguishing should only be done after the fuel supply has been cut off. At 20 percent LEL gas detection, the emergency ventilation fans will start, increasing air changes to a minimum of one cubic foot per minute of outside fresh air per square foot of floor space but not less than six air changes per hour. If the gas concentration continues to rise to 40 percent LEL, an ESD will be activated causing the facility to shutdown and isolate. If the module internal air temperature should drop below 40 degrees the emergency ventilation system will be shutdown and a facility shutdown will be initiated if the gas concentration increases to 40 percent LEL.

13.2 CRITERIA

Safety and Loss Control Regulations

The facilities will be designed in accordance with 30 CFR 250 Chapter II "Oil and Gas Operations in the Outer Continental Shelf", 33 CFR 140 Subchapter N, "Outer Continental Shelf Activities", 33 CFR 67 "Aids to Navigation on Artificial Islands and Fixed Structures", 18 AAC 75 - State of Alaska Spill Prevention and Response regulations, API recommended practices, Uniform Building, Fire, Mechanical and Plumbing Codes, 1997 edition, National Electrical Code, 1997 edition, BP Recommended Practices, BP Alaska specifications, and other federal and state regulations and other international standards, as appropriate. The design will be suited to the safe execution of operational requirements as written in the Alaska Safety Handbook (ASH). The following points list measures that will be taken to reduce emissions and/or leaks:

- A regular, systematic walk-through of the plant will enable the operators to identify leaking components and plan their repair or replacement
- Gas detectors will be located around the plant to detect and warn of gas leakage

Control and Monitoring

The Liberty facility design utilizes a central control philosophy that facilitates unattended operation. The technology being employed will allow remote access to process control functions that will enable offsite control supervision and maintenance. Remote control supervision will allow a person at any other site equipped with a data link to monitor the control system operations. An additional option for this type of system allows remote instrument calibration and trouble shooting. The facilities will have supervisory control and data acquisition (SCADA) systems capable of all production control functions, including well testing, volume accounting and pipeline leak detection. The control system will have a human machine interface (HMI) allowing operator control of the plant operation.

Shutdown Systems

Standalone shutdown systems will be provided to generate safe and logical plant shutdowns from field shutdown inputs, manual shutdown stations and the F&G system. These systems will have the capability to generate first out alarm and shutdown sequence, and be able

to record the sequence of events. A hard wired manual push-button ESD system will be provided for selected critical shutdowns. This will be separate from the main Programmable Logic Computer (PLC) based shutdown system. Redundant F&G PLC's will be provided with inputs from the F&G detectors and manual stations, and with appropriate outputs to the ESD/plant shutdown systems. The design of any depressuring system will take full account of temperature effects on equipment metallurgy.

Shutdown systems will have on-line test facilities unless the related equipment can be taken off-line without disruption to production, or the test can be made on line. Use of test facilities will be protected and all test overrides will be alarmed in the central computer system.

After the activation of a shutdown system, the facility must be restarted following a standard reset philosophy. The resets will be activated from the HMI, but will not allow equipment startup without human intervention. The resets will not activate until specific permissives, as required for the equipment and plant, are met.

Flares and Vents

The flare system will be designed in accordance with the required relief capacity for the plant. The flare systems are required to be smokeless in their operation, and have the capability for remote ignition, or instantaneous ignition. Flare and vent systems will have heat tracing to a level appropriate to prevent ice plugging of the flare or vent. Attention will be paid to the metallurgy of any vent subject to the cryogenic affect of high pressure depressurization.

Telecommunications

Operational telecommunications requirements are:

- Communication system providing access to the national telephone network
- Communication links (tie line) with local BP network
- Data transmission capability for PC and MMS connection
- Mobile radio system with effective coverage over the facility area, and
- Mobile radio system linked to Alaska Clean Seas, or other spill response contractor.

Safety System Testing

All pressure and level shutdown field devices and SDV actuators will be tested once per month. The ESD circuit will be tested once per month to verify operation of the system actuates the surface and subsurface safety valves in accordance with MMS regulations. All testing will be done in accordance with API RP 14H. Relief valves certification will be done annually in accordance with MMS regulations.

Equipment Identification

The plant, equipment and main/critical instruments will be identified by a site, tag numbering system. Equipment that can be changed out on a like-for-like basis i.e. relief valves, should use the manufacturers serial numbers as the identifier in addition to the above. The

tagging identification convention will be consistent with the MMS and information management system.

Documentation And Information Management

A documentation and information management philosophy will be prepared. The following information will be prepared for the facility:

- Operations Manual
- Operating Procedures
- Design Dossier
- Safety Manual
- Emergency Procedures
- Engineering Manuals
- Maintenance Manuals
- Training Manual

14. TRAINING

BPXA is developing a comprehensive training program for this offshore development. This training program will address environmental awareness, environmental compliance, comprehensive safety issues, and operations. All construction, drilling, and operations personnel will receive an appropriate level of training in pertinent subject areas. Training will be in compliance with 30 CFR Subpart O - Training, and with the stipulations of Lease Sale 144.

Topics to be addressed in the training program, which is currently under development, include:

- archaeological resource protection
- protection of biological resources and habitats
- subsistence and other socioeconomic issues
- permit compliance
- compliance reporting
- monitoring requirements and reporting
- drilling well control
- well completions
- well workover control
- production safety systems
- training documentation systems
- pollution prevention/best management practices
- spill reporting procedures
- spill response and Incident Command System
- cold weather safety

15. PROJECT TERMINATION

The expected life of the Liberty field is 15 years, and the minimum project operational life is 20 years. However, the actual service life of the project will depend on several factors. Once the island is constructed, infill drilling or possible satellite development could extend the service life of the island, production facilities, and pipeline system. Likewise, since the pipeline system will be operated as a common carrier, BPXA or another entity could continue to use the pipeline for other, future purposes after the Liberty reservoir has been depleted.

BPXA will decide when to abandon the project facilities based on the need for continued use of the facilities. At the time the project is no longer needed, BPXA would either begin abandonment procedures according to the permit conditions and regulations in force at that time, or enter into negotiations to transfer ownership of the project to another entity.

MMS regulations provide specific requirements for well abandonment, but are not prescriptive for island abandonment (removal is required to a depth approved by the Regional Supervisor). OCS pipelines may be abandoned in place, or removed if required by the Regional Supervisor. Laws and regulations pertaining to Alaska Department of Natural Resources and U.S. Army Corps of Engineers approvals for this project also provide for discretion in termination and abandonment procedures.

Actual detailed abandonment procedures will not be determined at this time, but will be developed as a project modification at the time BPXA or any future owner or operator decides to terminate the project. Just as project construction is subject to numerous overlapping local, state, and federal authorities, abandonment will be subject to multiple agency reviews and approvals. In general, most of the Liberty permits issued to authorize construction will contain clauses requiring approval of abandonment procedures. The discretion allowed in identification of termination and abandonment procedures allows for full consideration of the environmental impacts of removal options, and allows evaluation of any benefits from leaving certain facilities or structures in place at the time of abandonment.

Some precedent has been set through approved abandonment of several islands built for exploratory drilling in state and federal Beaufort Sea waters. These abandonment procedures have involved removing island slope protection, removing island facilities, removing wellheads, pilings, and other structures to below the mudline, and plugging and abandoning wells. Natural wave, ice, and current forces then gradually erode the island surface. This procedure was used for Tern Island, which is located about 1.5 miles from the proposed Liberty Island.

BPXA plans to remove bags at the same time other island abandonment activities occur, subject to laws, regulations, and permit requirements in force at the time. A possible technique might be to open the bags, deposit the gravel, and remove the polyester bag material from the site. An alternate technique could be to remove the gravel-filled bags from the site.

16. SINGLE SEASON SCHEDULE OPTION AND CONSTRUCTION CONTINGENCIES

The planned schedule is believed to be fully executable, based on BPXA's and the Alliance contractors' collective long-term experience in North Slope construction and logistics. However, to ensure schedule flexibility, BPXA is retaining an option for single season construction. This single season option is illustrated in Figure 16-1.

Several aspects of project construction and drilling and production operations would differ under a single-season construction scenario. These are outlined below:

- all construction completed in a single year
- a single sealift
- simultaneous drilling operations and module installation and hookup
- increased traffic volumes associated with construction (see Table 16-1).
- reduced length of time temporary diesel storage will be required
- single season gravel mining

Another option to the 2-year Base Case construction schedule that has been considered in project planning is mobilization of the drill rig over an ice road. If BPXA used this option, instead of mobilizing the rig by barge the rig would be mobilized by ice road during the second winter of construction. Temporary diesel storage (about 21,000 barrels) would be required for this option.

In addition, BPXA has identified possible worst case contingencies if unusual weather conditions upset the planned schedule. If extremely warm weather limits ice road construction, thereby curtailing the window of opportunity for island or pipeline construction, BPXA would complete construction during the following winter. Likewise, if unusual ice conditions prevented the module sealift from reaching the Liberty Island, installation would be delayed a year.

Table 16-1
Estimated Liberty Transportation Requirements (Single Season Option)

| Access Type | <u>Construction</u> | | | <u>Drilling and Production Operations</u> | | |
|---|---|-------------------|-------------------|--|------------------|--|
| | Summer | Breakup/Freezeup | Winter | Summer | Breakup/Freezeup | Winter |
| <u>Single Season Option with Camp Barge</u> | | | | | | |
| Aircraft | 5-10 trips daily | 10-20 trips daily | 10-20 trips daily | 3 trips weekly | 1 trip daily | 3 trips weekly |
| Surface | - | - | 400 trips daily | - | - | 400 trips per season during drilling; 100 trips per season post-drilling |
| Marine | 100 local round trips, plus sealift and barge camp. | - | - | 4-5 trips per month during drilling; 4-5 trips per season post-drilling. | - | - |
| <u>Single Season Option without Camp Barge</u> | | | | | | |
| Aircraft | 10-20 trips daily | 10-20 trips daily | 10-20 trips daily | 3 trips weekly | 1 trip daily | 3 trips weekly |
| Surface | - | - | 400 trips daily | - | - | 400 trips per season during drilling; 100 per season post-drilling |
| Marine | 150 local round trips, plus sealift | - | - | 4-5 trips per month during drilling; 4-5 trips per season post-drilling. | - | - |

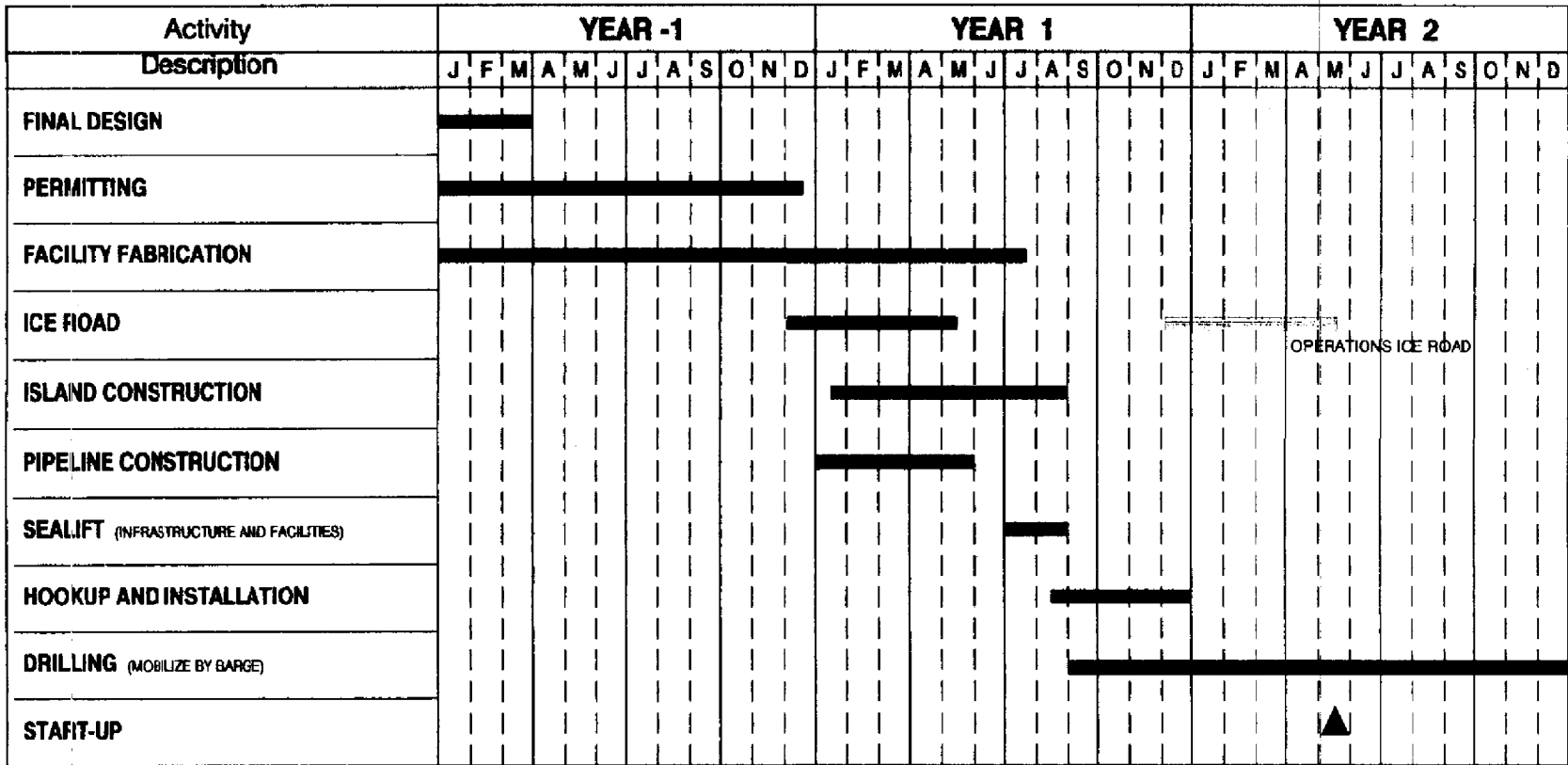

BP EXPLORATION (ALASKA) INC.

**LIBERTY DEVELOPMENT
SCHEDULE SINGLE SEASON
OPTION**

DATE: Rev. April 2000 SCALE: N/A FIGURE: 16-1

APPENDIX A

**LIBERTY DEVELOPMENT PROJECT
WASTE DISPOSAL WELL**

Table of Contents

| | |
|----------------------------------|------|
| Introduction..... | A-1 |
| Geology..... | A-3 |
| Well Construction..... | A-9 |
| Waste Types and Volumes..... | A-14 |
| Operating Characteristics..... | A-17 |
| Waste Confinement..... | A-22 |
| Subsurface Water Salinities..... | A-25 |
| Assurance and Reporting..... | A-26 |

List of Figures

| | |
|------------|---|
| Figure A-1 | Well Bottom Hole Locations |
| Exhibit 1 | Type Well Log |
| Exhibit 2 | Geologic Cross-section (available upon request) |
| Exhibit 3 | Geologic Cross-section (available upon request) |
| Figure A-2 | Structure Map |
| Figure A-3 | Structure map |
| Figure A-4 | Well Construction Diagram |
| Figure A-5 | North Slope Disposal Projects |

Introduction

An integrated approach to managing wastes from drilling rig activities, production operations, maintenance work, and camp living quarters has been developed for BPXA new developments such as the Liberty project. The corner-stone of this approach involves combining the mechanical grinding of drilling solids with deep well injection to permanently dispose of drilling wastes. With this technology, BPXA is working towards eliminating the traditional use of reserve pits for storage or disposal of drilling wastes. The Liberty facility will use the grind and inject method to handle muds and cuttings from drilling operations, as well as the smaller volumes of oily production sediments coming from well workover-stimulation operations and vessel-pipeline cleanouts.

The Liberty waste disposal system will consist of a solids grinding plant; a pipeline network that collects routinely generated and compositionally consistent wastes from the slurry plant, process vessels, and camp sewage; manifolding hookups for intermittent disposal of batch loads; and an injection facility consisting of tankage, pumps, screens, controls, and an injection well. If project life lasts 20 years, total waste disposal could consist of injecting approximately 6.0 million barrels.

Injection capability will be critical to Liberty development because it is remote and isolated from other North Slope infrastructure. The disposal system itself is a key component of the overall BPXA environmental program and goal of zero surface disposal of wastes. The disposal well will be the first well drilled when drilling rig activities begin, targeted for January 2003.

BPXA will apply for the option to drill two disposal wells from the Liberty offshore island. Permitting two wells allows for necessary operational flexibility and redundancy in the event of mechanical well problems; however, it is not anticipated that the second well will be needed. The bottom hole locations of disposal wells WD-1 and WD-2 are shown on Figure A-1 with the other 22 oil reservoir development wells.

The wells are sited in an area where there are no fresh water aquifers below the 1730-foot-thick permafrost. The subsurface geology is very compatible with the proposed disposal process. The receiving zones (sandstones) are extensive, free of any influential faulting in the area, and interbedded with thick shale and siltstones that make up the confining intervals. Similar injectate has been successfully disposed of into these storage reservoirs for many years at Prudhoe Bay in the Class I and Class II Underground

Injection Control programs administered by the U. S. Environmental Protection Agency and Alaska Oil and Gas Conservation Commission respectively.

This document describes the disposal well injection zone, well construction, operation and abandonment plans, and a brief characterization of the waste streams designated for disposal by injection. It was prepared to supplement to the Development and Production Plan (DPP) submitted to the U.S. Minerals Management Service (MMS). The official application to drill will be prepared according to the U. S. Code of Federal Regulations, MMS instructions, and be submitted in time for thorough review.

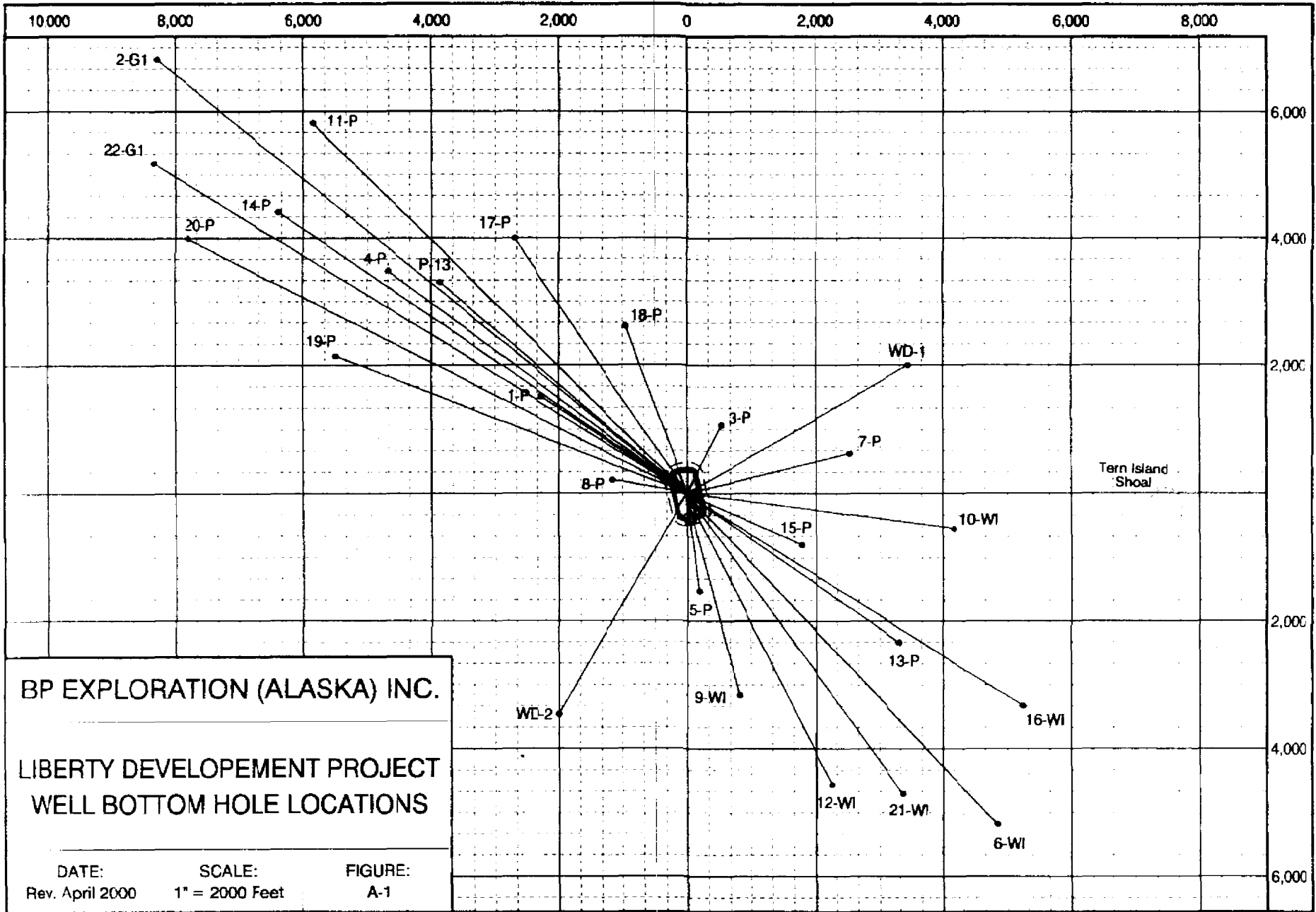

Geology

General Geology

The geology of Tertiary (Paleocene to Oligocene) age stratigraphy in the Liberty area is described with specific reference to the proposed injection and confining zones. A series of informal key markers are identified and correlated from wireline logs. These are summarized in the following table and are shown on the type log (Exhibit 1) and on the regional cross-sections of Exhibits 2 & 3. The markers are strictly litho-stratigraphic, but can be correlated regionally. The intervals comprise siliciclastic rocks in the West Sak, Ugnu and Sagavanirktok Formations overlying a thick shale sequence called the Canning Formation (equivalent in part to the Seabee shale to the west). Structure maps on key marker horizons are presented on Figures A-2 and A-3.

The overall sequence including the Canning, West Sak and Ugnu strata comprise the final regressive sequence in the Middle Brookian of Tertiary (Paleocene to Middle Eocene) age. The overlying Sagavanirktok strata comprise several cycles of transgression-regression in the Upper Brookian section of younger Tertiary age (Upper Eocene to Oligocene).

The Middle Brookian sequence shows a pronounced upward shallowing cycle starting with deep water marine shales (Canning Formation) followed by shelf shales, siltstones and very fine to medium grained sandstone (West Sak Formation). This is capped by shallow shelf and coastal plain / fluvial fine to medium grained sandstone (Ugnu Formation). The strata in this sequence are moderately consolidated. Sandstone porosity is susceptible to degradation by compaction (rather than cementation) due to the presence of ductile lithic sand grains.

The Upper Brookian is composed of a series of transgressive-regressive cycles. Each Upper Brookian sequence typically begins with a major shale unit which is the result of a transgression creating a subsiding muddy shelf. This is overlain by a sand unit recording first regression and then another transgression. The sands are fine to coarse grained (some gravel) and of fluvial to shallow shelf origin. The final transgressive shale is overlain by 3000 to 4000 feet of largely coarse sand and gravel resulting from the final regressive phase of the Sagavanirktok. The Sagavanirktok sands and gravels are loosely consolidated and have maintained much of their original porosity framework owing to their shallow burial. The base of the permafrost intercepts the shallow coarse-grained member of the Sagavanirktok and is evident in all wells in this coastal area.

Detailed Geology of the Proposed Injection and Confining Zones

The geologic subdivisions encompassing the confining and proposed injection zones are shown on the type log, Liberty #1 (Exhibit 1) and on the regional correlation cross-sections, Exhibits 2 & 3. Liberty #1 was selected as the type log based on its proximity to the proposed development area and disposal well site. Other wells near to the development area are the Tern Island #1, #2 and #3 wells. These four wells best depict the expected properties of the confining and injection zones. These, and other wells are included on the regional cross sections for the sake of showing continuity of marker horizons and stratigraphy. The lithologic columns for wells on the cross-sections were purchased from a commercially available source (AMSTRAT), and are not considered to be a completely reliable indication of lithology. However, they are included on the cross sections to help visualize the general lithology.

The following table summarizes the Tertiary stratigraphy and markers used in this report. The markers define two gross injection intervals, bounded by three major regional shale units. Informally, the two injection zones are referred to as the upper and lower injection zones, and the bounding shales are called the upper, middle, and lower confining shales. Otherwise, the stratigraphic terminology follows that of workers at the US Geological Survey (Molenaar, Bird and Kirk, 1986 and Molenaar, Bird and Collett, 1986).

Stratigraphic Summary of Proposed Injection & Confining Zones

| Tertiary Age | Formation / Marker | Depositional Environment/Lithology |
|---------------------|-----------------------------------|--|
| Oligocene | Sag FM. - permafrost barrier | shelf sands overlain by coarse fluvial clastics |
| | -----marker 1 | <i>Top of Upper Confining Zone</i> |
| | Sag FM. - shale barrier | marine shelf mud and sands |
| to | -----marker 2 | <i>Top of Regional Transgressive Shale</i> |
| | Sag FM. - major shale barrier | marine shelf mud and silts |
| | -----marker 3 | <i>Top of Upper Injection Zone</i> |
| late Eocene | Sag FM. - injection zone | marine shelf bars to fluvial deltaic sands and mud |
| | -----marker 4 | <i>Top of Middle Confining Zone</i> |
| | Sag FM. - major shale barrier | deep to shallow shelf shales and siltstone |
| mid Eocene | -----marker 5 | <i>Top of Lower Injection Zone</i> |
| | Ugnu FM. - injection zone | shoreline to fluvial deltaic coastal plain sands |
| | -----marker 6 | <i>West Sak / Ugnu Division</i> |
| to | West Sak FM. - injection zone | shallow shelf shale, siltstone and sandstone |
| | -----marker 7 | <i>Top Lower Confining Zone</i> |
| late Paleocene | Canning FM. - major shale barrier | deep shelf to bathyal shales |

Note : FM. = Formation

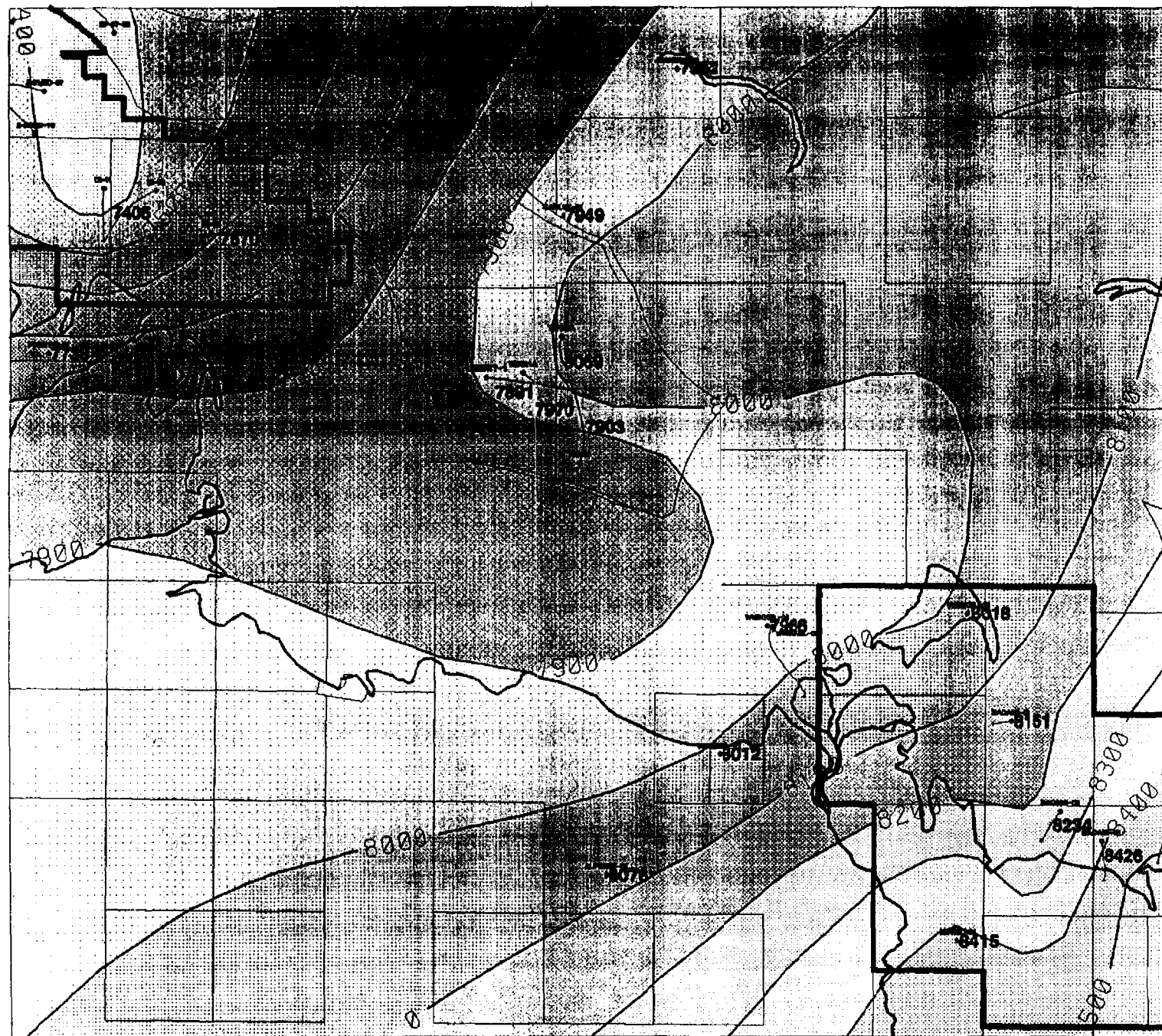

BP BP EXPLORATION (ALASKA) INC.



Contour Interval 100'

BP BP EXPLORATION (ALASKA) INC.

**Marker 7 Structure
Base Injection Zone**

DATE: 11/15/07
BY: J. J. JONES

Basal Confining Zone

Canning Formation: In the Liberty area, the name Canning Formation is used for the thick (2,000-3,000 foot) shale unit which lies beneath West Sak Formation and above the Hue Shale (includes the "HRZ" unit). In the Prudhoe Bay Unit this unit is called the Colville Mudstone, or the Seabee Formation. In this area, approximately the lower third of the Canning Formation is Upper Cretaceous in age and the upper two thirds is Lower Tertiary (Paleocene to Eocene) age. This thick unit chiefly contains shale and shaley siltstone originally deposited as muddy sediments spread on a deep marine slope and basin plain with maximum water depths of around 3,000 to 4,000 feet. The marine slope prograded to the Northeast. These slope sediments are overlain by deposits of the marine shelf, shoreline and coastal plain environments. The transition from the slope to the shelf is marked by the gradational contact (marker 7) of the Canning Formation and overlying West Sak Formation.

The shales and muddy siltstones of the upper Canning Formation are regionally continuous. The contact with the overlying West Sak Formation (marker #7) is gradational and subject to irregularity caused by intertonguing of West Sak fine grained sandstones with the underlying Canning shales.

The Canning Formation contains various discontinuous sand units of deep water turbidite depositional origin. The Badami Sands within the Badami Unit (located about 10 miles southeast of the Liberty Field) are well developed and are the target for oil production development. Near Liberty, Canning sands are less common. The Canning Formation in the Liberty #1 well has an upper slope sand near the top of the formation (about 8100 feet vertical depth subsea (TVDss). This sand is water bearing and appears to be discontinuous since it is absent in the nearby Tern Island wells. No hydrocarbon bearing Canning Formation sands are known to exist in the Liberty Field area.

Lower Injection Zone

West Sak / Ugnu Formations: This interval is approximately 1500' thick in the field area. The top is defined by marker 5 and the base is defined by marker 7. Marker 6 subdivides the interval into the Ugnu (upper) and West Sak Formations (lower). The primary injection target is a blocky sand at about 7500 feet TVDss, located at the base of the Ugnu Formation (above marker 6). The specific net sand interval is about 100 feet thick and has about 24 percent porosity. This sand exists in all wells near the Liberty Field, and is expected to be present at all possible injection well locations. Other less

well developed discrete sands also exist above and below which could also be used for waste disposal because in total they constitute an effective disposal interval.

Middle Confining Zone

Sagavanirktok Formation: This shale interval is approximately 400-500 feet thick in the Liberty area and is regionally correlative across much of central North Alaska. The top is defined by marker 4 and the base is defined by marker 5. This shale is the result of a major regional flooding event at the beginning of the Upper Brookian and forms an effective seal for waste confinement.

Upper Injection Zone

Sagavanirktok Formation: This gross section is approximately 1000 feet thick in the field area. The top is defined by marker 3 and the base is defined by marker 4. Numerous sands are identified as good potential injection intervals. A 110 foot thick sand at 5400 feet TVDss has 27 percent porosity and a 70 foot sand at 6000 feet TVDss has 21 percent porosity. These two sands are more shaley than the shallowest sand at 5000 feet; however they still constitute viable injection targets if the upper injection zone were to ever be used. Other less well developed sand intervals also exist in this and could potentially be used for waste disposal. Water samples were taken from the sands at 5000 feet and 5400 feet for salinity analysis. This is discussed in a following section.

Regionally correlative shales exist within the upper injection zone which will further act as effective barriers to vertical movement. The type log (Exhibit 1) shows three markers (SV1, SV2, & SV3) which mark the base of three shales that are present in all wells in the Liberty area.

Upper Confining Zone

Sagavanirktok Formation: This gross interval is approximately 1500' thick in the field area. The top is defined by marker 1 and the base is defined by marker 3. Marker 2 defines the top of a regionally continuous shale that occurs near the base of the confining zone. Above marker 2 is a thick shaley interval with interbedded sands that will further aid fluid containment.

Structure

Structure maps on the top and base of the proposed injection zone (markers 3 and 7) are shown on Figures A-2 and A-3. These maps were constructed from well data and are not directly constrained by seismic data. The structural dip on the marker horizons is relatively simple with dips of about one to two degrees toward the northeast to east. Examination of the shallow horizons on the 3D seismic data do not indicate any significant offsets due to natural faulting.

Outcrops and Recharge

None of the formations proposed as confining, arresting or injection zones outcrop in the general area. Within the Badami Unit to the east, the top of the upper confining zone is 3500 feet deep and the top of the proposed injection zone is 5000 feet subsea. An examination of regional seismic lines shows that these zones come near or to the surface approximately 25 miles southwest of the Liberty area. Approximately 15 miles southwest, the upper confining zone and subsequently the injection zone is projected to intercept permafrost. The thick permafrost (generally about 2000 feet or greater onshore) is a barrier to recharge and discharge.

References

- Molenaar, C. M., Bird, K. J., Kirk, A. R., 1986, Cretaceous and Tertiary stratigraphy of northeastern Alaska, in Talleur, I. L., and Weimer, Paul, eds., Alaskan North Slope Geology: Pacific section, Society of Economic Paleontologists and Mineralogists.
- Molenaar, C. M., Bird, K. J., and Collett, T. S. 1986, Regional Correlation Sections across the North Slope of Alaska, U. S. Geological Survey Miscellaneous Field Studies Map, MF-1907.

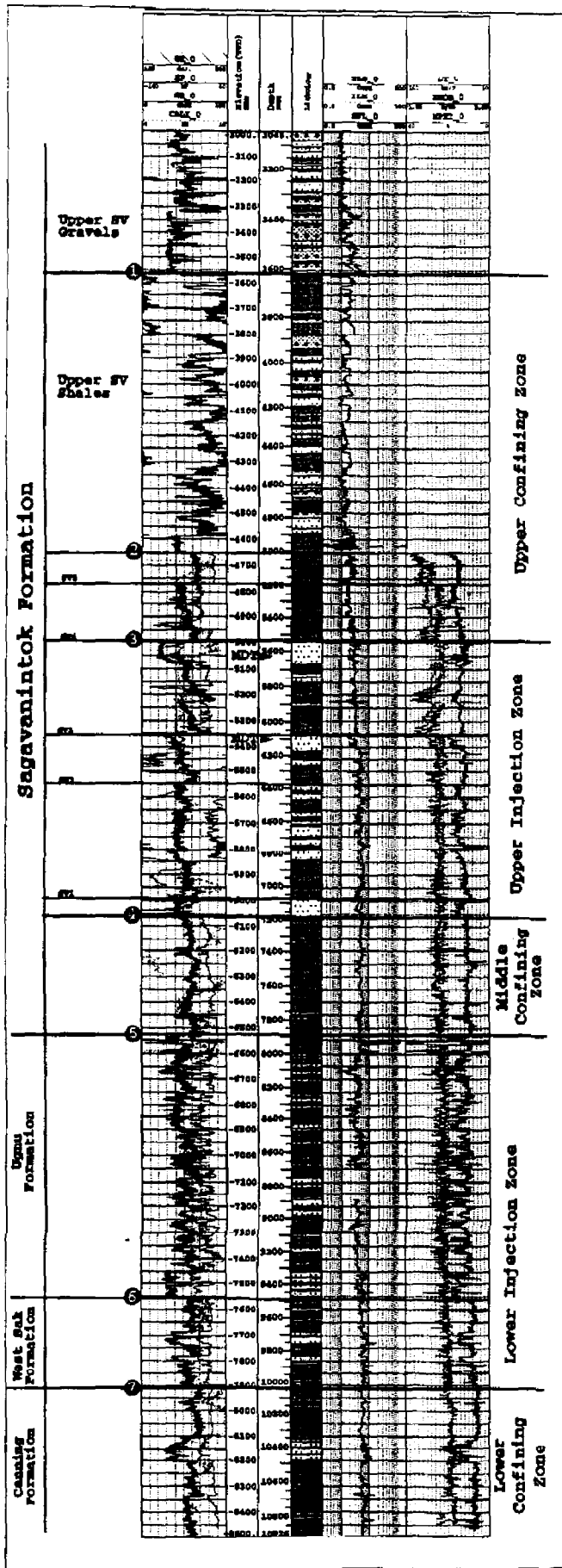

Exhibit 1 Type Log

Proposed
Injection Zone

BP

LIBERTY-01

56-201-00000-00

FORMER: B. D. ERMICZAKOS (AMATA), ET. AL. 14124E EMEKATOS: 13
 MATTYPE: 70-27919808 NEATWEENET IEX: 248
 MOENTAGE: -147-48642826 EMEKATOS NEAF: IEX: 43.8
 0 FOODDATE: 401300-7026 00NNEA OETTO: 14620
 0 FOODDATE: 7796911.092 XEITHAM RUTT: 2000
 00DNOITAM 03TT: Neveer DATE MOHED: 1-AZI-97 @ 18
 DATE FMOOTED: 28-0yv-97 XEITHAM ITAME: 1.2400

| AZTR (ICET) | IN | INT | INT | ATA | BOY | TOP | SP TRAC |
|---------------|-----------|-----------|-----------|-----|-----|-----|---------|
| 3000.0-8000.0 | 1.18 @ 70 | 1.46 @ 70 | 1.04 @ 70 | 0.8 | 204 | 20 | 6.76 |

Exhibit 2 and Exhibit 3

Geologic Cross-sections

These exhibits are not reproduced here due to size and complexity of the drawing. Copies are on file with the MMS and available for review; copies are available upon request from BPXA (contact Karen Wuestenfeld at 564-5490).

Well Construction

Construction Procedures and Details

Up to two disposal wells could be directionally drilled to bottom hole locations with departure of approximately 4000 feet, and to a final vertical depth of approximately 7600 feet. The drilling program for the initial well, WD-1 calls for kicking out from the vertical at 500 - 800 feet, building angle to 40 degrees, and maintaining an accuracy that will allow for hitting within 200 feet of the target at the upper injection zone. The angle will then be allowed to drop to approximately 25 degrees for the rest of the well course. Construction requirements will exceed specifications required by the Title 30 Code of Federal Regulations and State of Alaska regulations.

The well casing, cementing, and completion program is depicted in Figure A-4. The surface hole will be logged as specified to ensure that the surface casing shoe is set near the base of the upper confining zone. This placement, plus the use of Class-G cement as the tail slurry around the casing shoe and cement to surface will ensure good zonal isolation. A full logging program will be run in the lower 9 7/8 hole. The 7 5/8 casing string will be cemented with an excess volume to ensure good bonding between it and the 10 3/4 surface casing. Zonal isolation will be verified by cement bond logging in both surface and intermediate casing strings. Surface and intermediate string integrity will be verified by pressure testing.

The tubing- casing annulus will be isolated above the injection intervals by a hydraulic set packer. A landing nipple to accept a wire line deployed downhole check valve will be installed in the tubing string. The annulus will be filled with corrosion inhibited sea water with a diesel cap for freeze protection. The tubing and tubing-casing annulus will be pressure tested to 3000 psi. Should the well not pressure test satisfactorily the tubing will be removed and the problem corrected before the drilling rig moves off the well.

Injection lines to the well will be heat traced and insulated. The completion tubing will also have heat tracing installed to 1730 feet should it be needed to prevent freezing in an anomalous situation.

Figure A-4

Liberty Disposal Well WD-1

Proposed Completion Schematic

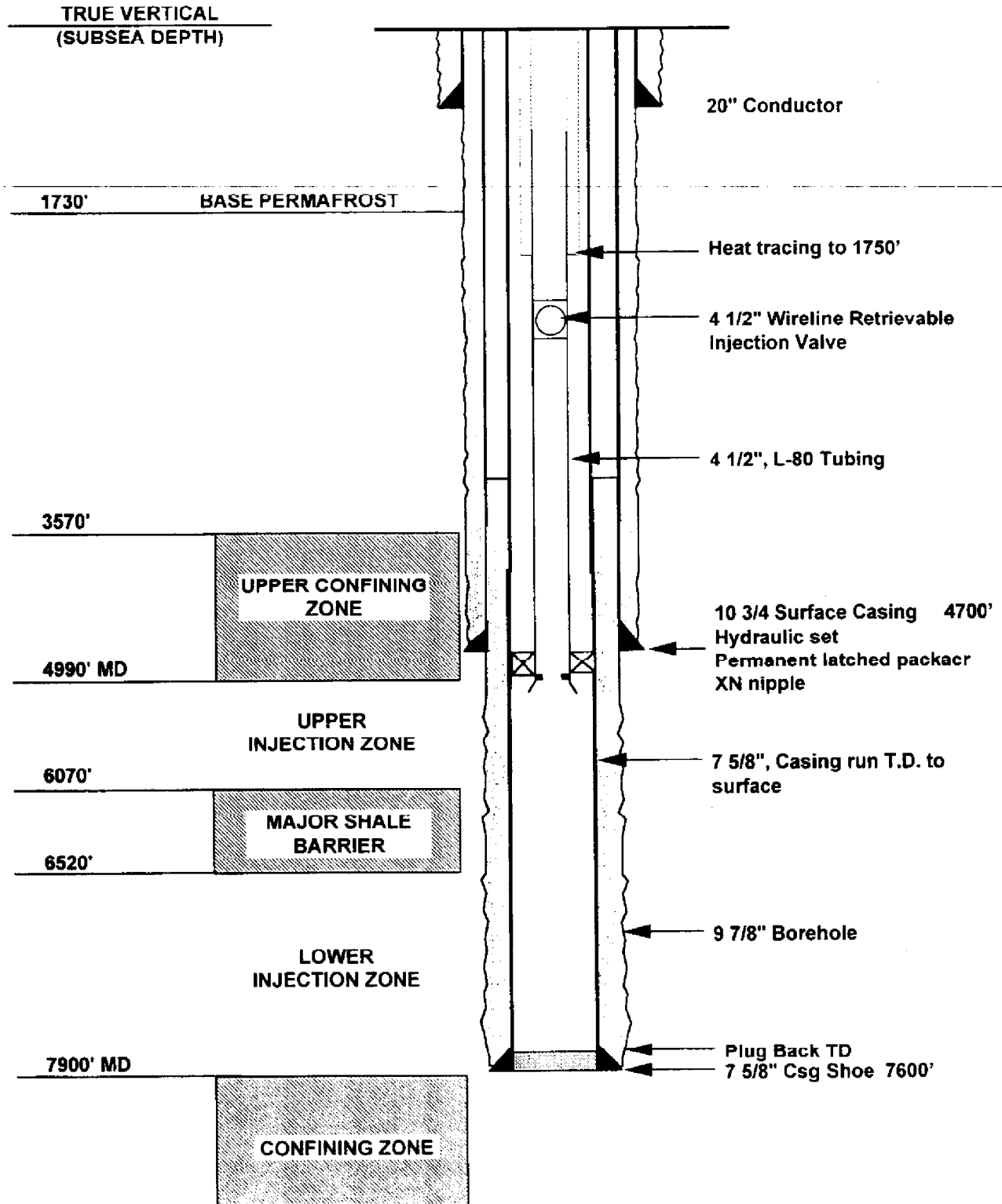

Proposed Drilling and Completion Program : Well WD-1

Surface location : Northern end of drilling row

Bottom - hole target location Azimuth : North 60 degrees East (average)
Departure : 4000 feet at total depth (TD)

Target accuracy 200 ft radius at top injection zone

Estimated start date : February 2001

Maximum angle: +/- 40 degrees

Kick off depth : 500 - 800 feet MD/TVD

| <u>Item and Depths</u> | <u>Feet Subsea</u> |
|-------------------------------|---------------------------|
| 20" Conductor | 200 |
| Base Permafrost | 1730 |
| Upper Confining Zone | 3570 |
| 10 ¼" Casing Shoe | 4700 |
| Upper Injection Zone | 4990 |
| Lower Injection Interval | 6520 |
| 7 5/8" casing shoe | +/- 7600 |
| Lower Confining Zone | 7900 |

Logging Program

Open Hole:

13 ½ Surface Hole : DIL/GR/SP/Caliper (From TD to 500')

9 7/8 Intermediate Hole: DIL/GR/SP/BHC/CNL

Cased Hole:

Cement bond log from 10 ¾ shoe up to surface.

Cement bond log from total depth to 10 ¾ shoe.

Directional survey from total depth.

Freeze Protection Plan

The tubing will be heat traced to +/- 1730 feet. The 4-1/2 X 7-5/8 annulus will be freeze protected with corrosion inhibited sea water with a diesel cap through the permafrost interval. As a contingency, diesel will also be available to pump down the tubing should a problem develop with the annulus systems.

Cementing Procedures

10 ¾ Inch Surface Casing :

Basis: Based on caliper survey, pump excess annular volume with returns to the surface. Lead slurry will be Cold Set III from surface to 500 MD below permafrost. Tail slurry to consist of class-G from 500 feet below permafrost to casing shoe.

Top Job : If no cement returns to surface the MMS will be notified. Appropriate logs and other tests will be conducted and procedures followed as specified by regulations dealing with surface casings.

7 5/8 Inch Injection String :

Basis: Annulus volume with 30 percent excess. Tail slurry to be class-G cement.

Construction Procedures

- Drive 20 inch conductor casing to 200 feet TVD. Move in drilling rig. Install diverter and function test .
- Directionally drill a 13 ½ inch hole to the surface casing point. Rig up and run E-line logs: DIL/GR/SP/ Caliper. Run and cement the 10 3/4 surface casing. Install blow out preventer (BOP) and pressure test per agency regulations.
- Run cement bond log from casing shoe to 500 feet.
- Pick up a bottom hole assembly (BHA) and run in hole. Test the casing to 2500 psi for 15 minutes.
- Drill a 9 7/8 inch hole through the proposed injection interval to a depth of approximately 7600 feet TVD. Rig up and run E-line logs: DIL/GR/SP/BHC/CNL.
- Run the 7 5/8 casing to TD. Cement the string from TD to above the surface casing shoe. Circulate out excess cement.
- Clean out the 7 5/8 casing with bit and scraper, circulate hole clean, displace to clean sea water and pressure test.
- Run a cement bond log from TD to the surface casing shoe.
- Run 4 1/2, L-80 tubing with heat tracing. Freeze protect annulus with corrosion inhibited seawater with diesel cap. Test the tubing and tubing-annulus separately to 3000 psi.
- Install the wellhead and test to 5000 psi. Release drilling rig.
- The drilling fluid program and surface safety system will conform to MMS regulations and to AOGCC Regulations 20 AAC 25.033.

Well Abandonment Plans

Abandonment plans for waste disposal wells will be implemented in accordance with the following procedures. At the time of final abandonment, these plans will be revised to reflect current MMS regulations and/or State of Alaska Oil and Gas Conservation Commission regulatory requirements, as well as utilizing current technology applicable to the condition of the well at the time. These agencies will be notified in sufficient time to witness the abandonment operation.

Placement of Plugs Above Lower Completion Intervals:

Two or more separate intervals could be opened in a disposal well during its life, with the sequence starting at the bottom. Should a lower interval become useless, it will be abandoned to ensure that it does not interfere with future injection activity. Integrity will be verified. Possible isolation methods include the leaving of hard fill-solid, and placement of cement caps, or mechanical plugs above the completion. The areas or intervals below and between plugs will be filled with fluid of sufficient density to control formation pressures. An upper interval would then be perforated. This process may continue up-hole as dictated by operating circumstances. After a well is no longer useful, steps will be taken for final well abandonment.

Final Well Abandonment :

Specific action plans can not be included because perforation intervals may vary depending upon how the disposal process proceeds. Also the type, grade, and quantity of cement used will depend on the well bore geometry and physical conditions existing at the time of abandonment operation. At closure, a rig will remove the tubing and place the appropriate plugs within the 7 5/8 casing. Plugs will be placed across any open perforated intervals, at the base of the permafrost, and below the mud line. The casings will be cut off below the mud line.

Waste Types and Volumes

Types of Wastes

Exploring for and producing oil and natural gas are industrial operations which unavoidably generate some waste. However, the vast majority of these wastes are non-hazardous. These non-hazardous wastes include drilling muds and cuttings, produced water not usable for enhanced oil recovery, and a class of waste termed "other associated waste."

Drilling muds are usually water-based mixtures of clays and weighting materials with small amounts of various additives. (Occasionally, an oil-based mud is used in special drilling applications such as highly deviated wells.) Muds serve to lubricate the drill bit, remove the cuttings from the well bore, and control the pressures in the underground formations. Cuttings are rock fragments removed from the well bore by the mud system.

Produced water that comes to the surface mixed with the oil and gas must be separated before the oil can be sent to the Trans-Alaska Pipeline. The majority of produced water handled each day is treated and then reinjected into the oil reservoir; a process that helps recover additional oil. Produced water that is recycled in this way is not considered to be a waste. At Liberty, most produced water will be returned to the oil reservoir; however, some small amount must be injected into the disposal well.

Other associated wastes specifically includes waste materials intrinsically derived from primary field operations associated with the exploration, development, or production of crude oil and natural gas. "Intrinsically derived from primary field operations" is intended to distinguish exploration, development, and production from transportation and manufacturing. With respect to crude oil, primary field operations include activities occurring at or near the wellhead and before the point where the oil is transferred from an individual field facility or a centrally located facility to a carrier for transport to a refinery or a refiner. It also includes the primary, secondary and tertiary production operations. Crude oil processing, such as water separation, de-emulsifying, degassing, and storage in tankage associated with a specific well or wells, are examples of primary field operations.

In general, the exempt status of an exploration and production waste depends on how the material was used or generated as waste, not necessarily whether the material is hazardous or toxic. Some major associated wastes which are covered by the Resource Conservation and Recovery Act (RCRA) oil and gas exemption are:

- Tank bottoms and pit sludges
- Wastes from well workovers and stimulations
- Pipeline pigging wastes
- Gas dehydration wastes
- Truck/tank/cellar wastewaters
- Spill residues and contaminated soils
- Produced formation sand and hydrocarbon soils

In addition to the three major classes of Exploration and Production (E&P) exempt waste discussed above, oil field operations create some non-exempt, non-hazardous wastes. Oil field wastes not intrinsically associated with the production of oil and gas but which are not hazardous will also be injected into the disposal well.

Typical oil field wastes acceptable for injection can include the following:

| | | |
|----------------------|--------------------------|---------------------------|
| Water Based Cuttings | Frac Sand | Contaminated Gravel |
| Oil Based Cuttings | Crude Oil | Produced Water |
| Water Base Mud | Diesel | Cement Wastes |
| Oil Base Mud | Methanol | Well Completion Fluids |
| Well Workover Fluids | Production Vessel Sludge | Rig Wash |
| Water Gel | Line Pigging Waste | Waste Rinsates |
| Fresh or Sea Water | Natural Gas Liquids | Glycols and Boiler Waters |
| Stimulation Fluid | Well Cellar Fluids | Misc Non-hazardous Waste |

The injection stream will also include domestic wastewater from the camp and stormwater run-off collected on the island surface. Camp wastewater comes from the kitchen, showers, lavatories, laundry, toilets, and any building drains. It typically has a suspended and dissolved solids content of less than one percent. Sewage and sludge are exempt from the regulatory definition of solid waste and are not subject to hazardous waste management under RCRA. The stormwater comes from rain and snow melt collected in surface sumps. Domestic wastewater and stormwater will be injected into the disposal well.

Liberty Injection Stream

The following disposal stream is projected for Liberty over a 20 year life.

The disposal stream can also be broken down in the following way.

The waste disposal system will consist of a solids grinding plant; a pipeline network that collects routinely generated and compositionally consistent wastes from the slurry plant, process vessels and wells; manifold hookups for intermittent batch loads; and an injection facility that consists of tankage, pumps and the disposal well. Treated effluent from the wastewater treatment facility will be piped to the injection facility. Stormwater sumps will periodically be pumped to the injection facility.

Operating Characteristics

Injection Volumes

The following table lists the volumes of liquids and solids to be injected. While both the drilling rig and plant are operating, the average monthly injection is expected to be 32,000 barrels. This would drop to approximately 18,000 barrels when the rig shuts down. A maximum disposal situation could require injecting up to 65,000 barrels per month since plant upsets, scheduled yearly shutdowns, well treatments, and workovers generate large volumes in short periods. It is therefore necessary to be able to inject this higher volume in any given month.

After the initial drilling program of 20 months, the rig will operate infrequently. Therefore, the expected cumulative injection over a 20 year project life is 6.0 million barrels.

Below is a summary of the waste disposal picture on a monthly and cumulative basis.

Injection Volumes and Rates

| | Injection Volumes - Barrels | | |
|----------------------------------|-----------------------------|---------------|--------------|
| | <u>Liquid</u> | <u>Solids</u> | <u>Total</u> |
| Normal Monthly Injection | | | |
| Rig Drilling | 29,800 | 2,200 | 32,000 |
| Rig Not Drilling | 18,000 | 14 | ~18,000 |
| Maximum Monthly - Rig Drilling | 62,300 | 2,700 | 65,000 |
| Expected Project Volume (20 yrs) | -- | -- | 6,000,000 |
| (including stormwater) | | | |
| Expected Solids Volume (20 yrs) | -- | -- | 70,000 |

Injection Pressures

Field experience from Prudhoe Bay solids disposal projects provides the basis to estimate pressure trends that will occur as the disposal process proceeds. The following tabulation shows the range of injection pressures that are estimated to occur through the life of a single well. This includes the time from when it is initially completed in a deep interval, through abandonment of that interval as it might become plugged with solids, and further through the well life as a shallower interval was used for storage. The intent is to use the deeper sandstone intervals as long as solids can be transported into and through the formation. However, progressive plugging may occur at any given set of perforations and ultimately further wellbore stimulations become ineffective, and a lockup situation evolves. In the event of a lockup situation, that interval would then be abandoned and an upper section of the well would be perforated.

The range of injection pressures are well above the fracture gradient for the receiving sands (approximately 0.65 psi/foot of depth). By necessity, the pressures must be at these levels since the receiving reservoirs must be fractured for a slurry, solids- type placement process to work. It should also be emphasized that the expected pressures, as shown, reflect operation of a well when no major plugging of the wellbore or region adjacent to it has occurred. Periodically, the solids being transported and the filter cake additives in the mud will combine to begin a gradual plugging of the then-existing fracture faces and matrix porosity. When this occurs, if injection operations cease and the wellbore is not flushed adequately with clear fluid, the pore throats and flow channels will become plugged. To re-initiate communication with the reservoir, surface pressure may sometimes have to be temporarily surged above those pressures listed in the attached table. This temporary surge acts the same as a stimulation procedure and flow can once again be established. This type of operation will be done with clean water.

Except for the necessary brief stimulation exercises, it is expected that injection pressures would generally be at or below the indicated levels, which are viewed as maximum levels that would occur as lockup of a completion interval progressed.

The following table summarizes the ranges of injection pressure expected to occur during the life of a single well under different operating conditions.

Range of Expected Injection Pressures

| | | Water (S.G.=1.0) | Mud/Solids (S.G.=1.3) |
|-------------------------------------|-----------------------------|---------------------|--------------------------|
| Upper Sand (+/- 5300 ft) | | | |
| <i>Expected Maximum Bottom Hole</i> | | | |
| <i>Pressures</i> | New Completions | 3,500 | 3,500 |
| | Old Completions | 4,900 | 4,900-Lockup |
| | Injection Gradient (psi/ft) | 1.0 | 1.0 |
| <i>Expected Maximum Surface</i> | | | |
| <i>Pressures</i> | New Completions | 1,300 | 700-1,300 |
| | Old Completions | 2,800 | 2,400-Lockup |
| Lower Sand (+/- 7300 ft) | | | |
| <i>Expected Maximum Bottom Hole</i> | | | |
| <i>Pressures</i> | New Completions | 4,950 | 4,950 |
| | Old Completions | 6,450 | 6,450-Lockup |
| | Injection Gradient (psi/ft) | 0.9 | 0.9 |
| <i>Expected Maximum Surface</i> | | | |
| <i>Pressures</i> | New Completions | 1,800 | 900-1,800 |
| | Old Completions | 3,300 | 2,400-Lockup |
| Type of Fluid Behavior | | Newtonian | Non-Newtonian |

Tubing-Annulus Corrosion

While some of the injected fluids will be corrosive relative to bare steel, serious degradation should not occur since most fluids are virtually non-reactive. Prior to injection; acids, caustics, and chemicals have been used, processed, handled, and are spent and virtually dead. These same wastes have been injected at the Prudhoe Pad-3 disposal facility for over 19 years and no corrosive tubing failure has occurred on any of those three wells. The critical subsurface tubulars are protected by tubing/packer/seal isolation and a non-reactive fluid placed in the tubing/casing annulus. The annulus fluid will consist of 8.6 lb/gal. inhibited seawater with a commercial inhibitor at the recommended concentration topped off with inhibited diesel through the permafrost zone.

Corrosion control is a subjective term since corrosion can rarely be eliminated, even at great cost. The function of well tubing and packers is to protect the casing strings from internal corrosion, stress, and abrasion. When the tubing deteriorates it is replaced. Should corrosive action weaken any internal down hole component or the surface piping, that part will be replaced.

Mechanical Integrity

An injection well has mechanical integrity if there is no significant leak in the tubular goods and if there is no fluid movement through vertical channels adjacent to the wellbore that transmit fluids outside the injection zone.

The first component of mechanical integrity may be demonstrated by a pressure test. The casing-tubing annulus will be pressure tested to 3000 psi when constructed and to 2000 psi when injection commences. The results will be reported to the MMS within 45 days. Additional pressure tests are performed after well workovers which affect the casing-tubing annulus and when necessary for diagnostic purposes. In addition, pressure monitoring of the annulus fluid permits an ongoing analysis of changing conditions. A small tubing-packer-seal leak or a casing leak to the formation would be detected relatively soon via this route. In the situation of a significant loss of tubing/packer integrity, the wellhead pressure would immediately be noted on the annulus. Pressure testing will initially be conducted yearly to verify internal integrity of the system. The MMS will be notified in advance of running these routine mechanical integrity tests so that a representative can witness it.

The second component of testing involves running either a temperature, oxygen activation, or tracer log to demonstrate the lack of fluid movement through the cemented

annulus adjacent to the wellbore that extends outside the injection zone. The log will be run according to good operating practices and interpreted by a knowledgeable log analyst. One of the acceptable diagnostic logs will be run within 45 days after receiving the permit, provided the well is in service.

Annulus Pressure Monitoring

The tubing-casing annulus volume will vary, and the annulus fluid itself will expand and contract due to temperature changes. Therefore, pressure monitoring for leaks, either internally from the tubing/packer/wellhead seal system or externally in the long casing string annulus, must take these fluctuations into account.

With an 8.6 lb/gal. fluid in the annulus, the internal hydrostatic pressure balances the original formation gradient. If a lighter fluid was present, an external casing leak would be reflected by a uniform rise in annulus pressure caused by the natural subsurface hydrostatic gradient. A heavier annulus fluid would bleed off to the formation and this would be reflected in a uniform loss of annulus pressure and fluid volume. An internal leak from the tubing/packer side would be seen as the annulus pressure tracking the rise and fall of the injection pressure. Any of the above events would initiate an annulus pressure test and other diagnostics to pinpoint the location of the problem.

Waste Confinement

Reservoir Fracturing/Solids Storage

The sandstone intervals that will be subjected to fluid and solids injection will initially fracture at a gradient of 0.65 psi/foot of depth. With injection pressures that may reach 1.0 psi/foot, fractures will occur. To maintain an open system for storage will require an internal pressure greater than the fracture gradient and thus the pore pressure of adjacent reservoir rock.

In the deeper sands, solids storage is expected to occur predominantly between the faces of a conventional planar fracture. When that fracture becomes filled and/or plugged, a second major fracture should occur with a somewhat different directional orientation. These fractures should all propagate in the vertical plane. Progressively, that completion interval may ultimately reach a lockup point and become useless.

In the intermediate sands, it is conceivable that a dendritic system would develop in which multi-conjugate fractures develop as appendages of a main single fracture. Alternately, secondary systems might also originate near the wellbore.

Should the upper disposal zone be required, it would be perforated in its basal area. Fracturing should be significantly different from fracturing which occurs at 7300 feet. Because this sand is not as consolidated, a dendritic variation may develop which could also involve rock solidification and movement along the fracture faces. This would further enhance solids storage and limit the dimensions of fracture growth.

The mechanisms of solids transport and placement will vary with depth because of the different rock properties controlling mechanical behavior in the different injection intervals. While it is hard to predict definitively what a fracture system will look like, the storage domain can be bounded based on years of slurry injection and extensive tiltmeter field tests, coupled with other field and laboratory experiments.

Comparing the Liberty disposal operation with other projects indicates vertical fracture growth might be in the 250 foot range. A maximum case might be 500 feet. The relationship of the Liberty project with others can be seen on the attached table (Figure A-5)

**Figure A-5
North Slope Solids Disposal and Fluid Confinement (11/97)
Comparisons to Northstar, Badami and Liberty Projects**

| <u>Facility</u> | <u>Injection Volume (Bbls)</u> | <u>Solids Volume (Bbls)</u> | <u>Instant Rate *(BPM)</u> | <u>Injection Depth (Feet)</u> | <u>Distance to Other Wells (Feet)</u> | <u>Fluid Confinement Data</u> |
|----------------------------|--------------------------------|-----------------------------|----------------------------|-------------------------------|---------------------------------------|---|
| CC-2 | 9 MM | 675 M | 3-10 | 3500 | +/-2000 | J-pad located 2500 ft. away but may be off fracture direction. N pad at 7000 ft. and Q-pad at 5200 ft. Three year average rate 4.4 BPM. |
| Pad-3 | 10 MM | +/-200 M | 1-5 | 2000 | 600-1000 | DS-6 located on strike with numerous wells within 1200 ft. All surface casings set below injection depth. Suspect horizontal fracture of limited radius and small reservoir pressure buildup. Shales at base of permafrost are sealing. |
| DS4-19 | 38 MM | <0.1% | 8-30 | 5930-6900 | 400-1500 | Produced water disposal prior to slurry injection. |
| DS4-19 | 8 MM 4 MM | 2000 M <0.1% | 22-27 22-27 | 5622-5627 5622-5627 | 400-1500 | Solids disposal test at high rates. Numerous pad wells within 400-1500 ft. Seismic events indicate communication up to +/- 4200 ft. Communicated with offset well 3/7/97 which terminated test. |
| Endicott P-18 | 6 MM | <0.1% | 1-6 | 7200 | +/-300 | Several wells within 300 ft. at injection depth. No reports of uphole fluid migration. Reservoir pressure build up at 300 psi level. |
| GC-1 | 158 MM | <0.1% | 7-40 | 5000 | 300-3000 | No annular communication problems at adjacent wells or on surrounding pads at 3000 ft. Pressure at outlying pads up +/-200 psi. (Volume thru 1/96) |
| GC-2 | 138 MM | <0.1% | 7-27 | 5000 | 300-3000 | |
| GC-3 | 83 MM | <0.1% | 7-10 | 5000 | 300-3000 | |
| Proposed Northstar Project | 116 MM 4 MM | <0.1% 80 M | 3-20 3-5 | 4000-6500 4000-6500 | +/-2200 +/-2200 | Produced water disposal volume (Maximum case). Project operational wastes. Average slurry injection rate is 1 BPM. Distance to other wells is 2200 ft., more at depth. Surface casings set below upper confining zone. Project startup - late 1999. |
| Badami Project | 4.3 MM | 60 M | 3-5 | 5000-7200 | +/-2300 | Distance to other wells is 2300+ ft. Surface casings set in upper confining zone. Average rate during slurry injection is 1 BPM. Well certified for operation in November 1997. |
| Proposed Liberty Project | 6.0 MM | 70 M | 3-5 | 5000-7600 | ---- | Injection operations similar to Badami & Northstar. Injection well separation +/- 2000 ft. expected. Average rate during slurry injection is 1 BPM. |

*(3PM = Bbls per minute)

Comparison With Similar Disposal Projects

There are six waste injection projects that can be used as analogies to Liberty. Five of them are on the North Slope and one in Canada. Their relevance is as follows.

- Prudhoe Bay CC-2 Facility :

This disposal plant has been in operation for over eight years, grinding up drill cuttings for injection into a single well. Disposal volume is over 9 million barrels. With a solids content estimated at 7-8 percent, 675,000 barrels of solids have been injected through an open hole completion at 3500 feet. The facility and well have operated without significant problems and no negative environmental impact. Oversight is provided by the Alaska Oil and Gas Conservation Commission.

- Prudhoe Bay Pad-3 Facility :

Since 1979 this facility has injected 10 million barrels of wastes which often included a significant volume of solids. At an estimate of 2 percent, this means 200,000 barrels of solids have been injected. These three closely spaced wells are completed at 2000 feet, just under the permafrost with 30 feet of separation. They are located about 600 feet from the edge of a development drilling pad with over 40 wellbores. Extensive logging and field testing have not detected any up-hole channeling or other problem. Oversight is by the Region 10 Environmental Protection Agency Office and the Alaska Oil and Gas Conservation Commission.

- Prudhoe Bay DS4-19 Demonstration :

Operations were initiated at this facility during the Spring of 1995 to test the feasibility of using grind-inject technology for reserve pit closure on a large scale. Injection rates were high with solids slurry placed in the same zones as those proposed for Liberty. The single injection well performed as planned and no uphole communication was detected by the many surrounding pad development wells until March 17, 1997. At that time approximately 2 million barrels of reserve pit muds and cuttings had been disposed of at injection rates of 22-27 barrels per minute (31.680 - 38.880 barrels per day). A detailed report on the surface breaching has been made to the Alaska Oil and Gas Conservation Commission. That report can be made available on request.

- Endicott Island Disposal Well :

At the Endicott oil field (Duck Island Unit) just west of Liberty, disposal well 2-02/P18 has injected over 6 million barrels since 1987. The solids content is less than one percent. The well is located on a drilling island with 55 other wells, all on 10-foot centers at the surface. Waste disposal at a depth of 7000 feet has been confined even though numerous wellbores pass within several hundred feet of the disposal well perforations. Oversight is by the Alaska Oil and Gas Conservation Commission.

- Badami Disposal Project :

The Badami disposal well was completed and went through extensive integrity testing in November 1997. It was certified to dispose of drilling muds/cuttings, production and domestic wastes, and other non-hazardous wastes; as planned for Liberty. The well was completed at 7100 feet. Approximately 600,000 barrels have been injected since November 1997. The average solids content is 11 percent. Oversight is by the Environmental Protection Agency and Alaska Oil and Gas Conservation Commission. Its relationship to Liberty can be seen on the attached table.

- Lloydminster, Alberta Canada, Celtic Formation Fines Disposal Project :

Approved by the Canadian Government, this plant has operated for several years disposing of large volumes of formation fines and sand generated by a steam flooded oil reservoir. Injection rate is reportedly high, at a depth of 2000 feet. No other operating details are known.

Formation Water Salinity in the Injection Zones

Log data shows the formation water in the injection zones to be saline in the Liberty area. The water salinities were calculated from logs using the industry standard Humble and the Archie equations. NaCl equivalent salinities were determined from standard nomographs. The results show the water salinities in the range of 15,000 - 35,000 ppm NaCl equivalent.

Formation water samples were taken in the Liberty #1 well with the Schlumberger MDT tool. Depths are shown on the type log, Exhibit 1. The samples were analyzed and gave the following results:

| | Depth feet (measured) (depth) | Measured salinity (ppm NaCl) | Humble calculated salinity (ppm NaCl) | Archie calculated salinity (ppm NaCl) |
|----------|--|------------------------------------|--|--|
| Sample 1 | 5612 | 27160 | 34700 | 32800 |
| Sample 2 | 6094 | 12550 | 31800 | 32500 |

The mud filtrate salinity was 1100 ppm NaCl so any contamination would have caused lower salinities to be measured and the samples represent a lower bound. The first sample compares well, but there could be some filtrate contamination in the second sample.

Summary Comparisons

The above data is consistent with log and fluid sample measurements obtained to the west at Endicott and to the east at Badami. The Endicott and Badami facilities have received no-underground-sources-of-drinking-water rulings from the Alaska Oil and gas Conservation Commission and the Environmental Protection Agency respectively.

Assurance and Reporting

Prior to facility startup a Waste Control and Analysis Plan will be developed that provides specific guidance to field operators. It will outline procedures for handling, classifying, sampling, analyzing, and recording waste volumes prior to injection in the disposal well. It will ensure that all activities and wastes disposed of will meet the criteria for exempt or non exempt non-hazardous waste.

Analysis of Injected Fluids

BPXA requests the option of disposing of third party waste from other offshore activities such as exploration drilling in the Liberty disposal well. Since the complex is not connected to a road system, uncontrolled third party access is not possible. Only RCRA exempt and non-exempt non-hazardous wastes will be injected.

Non-hazardous fluid determinations may be made based on laboratory data, material safety data sheets, and generator knowledge. "Personal knowledge" of a waste product may be substituted for analytical data according to 40 CFR 262.11 (c)(2), and therefore sampling and analysis may not be necessary for:

- (1) RCRA exempt oil-gas wastes.
(Chemical analysis is not required unless the operator desires it.)
- (2) Known non-hazardous industrial wastes as described in the Waste Control and Analysis Plan.
- (3) Domestic wastewater streams.
- (4) Stormwater run-off

The main waste generators are the drilling rig and grinding plant complex, the process facilities, and the field camp. Waste hard-piped from these sources to the injection facility will not require a manifesting record but will be tracked by a daily injection log. It is the intent of BPXA to do minimal sampling of the hard-piped streams since they are consistently predictable and are all exempt wastes. Operationally driven sampling will be done as needed and will be recorded in the Daily Events Log. Sampling reports will be filed, but no other records or forms will be maintained on these streams.

The intermittent processes that are not hard-piped will require a manifest for each batch operation, and the activity will be entered on other logs. Sampling will occur on the batches as dictated by manifest facts and other concerns. Analysis will be carried out at

the BPXA North Slope laboratory or other approved commercial laboratories prior to disposal.

BPXA intends to do some initial stream characterization work and follow up with periodic "fingerprinting" to confirm that wastes are within permit and disposal guidelines. Other North Slope disposal activities rely on manifest data, individual waste stream characterization, field screening tests, knowledge of a waste's origin, MSDS information, and/or analytical data to ensure that a given waste load can be accepted for disposal. Trained operators at those facilities are critical to proper handling of non-hazardous wastes. In December 1995, BPXA instituted a waste training pilot program which was expanded and implemented Slope-wide in early 1996. Similar or appropriate training will be implemented at the Liberty facility.

BPXA believes the proposed manifest system, operational procedures, and the Waste Control and Analysis Plan (yet to be developed) are sufficient for ensuring proper waste handling. Waste management and injection operations will be handled by trained Environmental Safety Technicians and "Certified Generators and Operators". Additional guidance and support will come from the Slope-based Health, Safety and Environment Supervisor and BPXA's Health, Safety and Environment Department staff in Anchorage.

Reporting

All volumes of material injected for disposal will be documented to meet agency reporting requirements.

APPENDIX B

**LIBERTY DEVELOPMENT PROJECT
ENVIRONMENTAL REPORT SUPPLEMENT**

TABLE OF CONTENTS

| | |
|---|-----------|
| Note to Reader | ii |
| 1. INTRODUCTION | 1 |
| 2. DEVELOPMENT ALTERNATIVES | 2 |
| 3. PROJECT DESCRIPTION | 2 |
| 4. AFFECTED ENVIRONMENT | 2 |
| 5. ENVIRONMENTAL CONSEQUENCES | 2 |
| 5.1 TWO YEAR CONSTRUCTION SCHEDULE..... | 2 |
| 5.2 DETAILED MINING PLAN..... | 5 |
| 5.3 CAMP BARGE DURING CONSTRUCTION..... | 6 |
| 5.4 INCREASED TRANSPORTATION LEVELS..... | 6 |
| 5.5 USE OF HYDRAULIC DREDGING FOR PIPELINE TRENCH EXCAVATION AND CLEANOUT..... | 7 |
| 5.6 AUTOMATIC SHUTOFF VALVE AT SHORE CROSSING..... | 7 |
| 5.7 GRAVEL BAGS ON PIPELINE BEFORE BURIAL..... | 7 |
| 5.8 INCREASED DIESEL FUEL STORAGE ON ISLAND..... | 7 |
| 5.9 INCREASED CRUDE OIL PRODUCTION OPTION..... | 8 |
| 5.10 INCREASED SIZE OF ISLAND FOOTPRINT..... | 8 |
| 5.11 ELIMINATION OF ISLAND STORMWATER DISCHARGE..... | 8 |
| 6. MITIGATION MEASURES | 8 |
| 7. COORDINATION AND CONSULTATION | 9 |
| 8. LIST OF PREPARERS | 10 |
| 9. REFERENCES CITED | 10 |

1. INTRODUCTION

This Environmental Report (ER) Supplement has been prepared in conjunction with issuance of Revision 2 of the BP Exploration (Alaska) Inc. (BPXA) Liberty Development and Production Plan (DPP). The DPP and supporting ER were originally submitted to MMS on February 17, 1998. This ER Supplement meets two major objectives:

1. Identifying and describing additional data concerning the Liberty project available since submission of the February 17, 1998 DPP and ER. This additional data includes reports of 1997 and 1998 field studies and/or analyses.
2. Briefly summarizing any change in project impacts expected as a result of project scope changes (as identified in the Note to Reader in Revision 2 of the DPP).

The basic content of Section 1 of the February 17, 1998 ER, which described the overall purpose and need of the project and the scope of the ER is still valid. The schedule, however, has been substantially changed, as discussed in Section 2 of the DPP. In addition, Table 1-1 of the DPP lists new permits and approvals needed for the Liberty project.

This Supplement is to be used in conjunction with the original February 17, 1998 Environmental Report as follows:

| Environmental Report (2/17/98 version) | Effect of Rev. 2 of DPP and of Supplement |
|---|---|
| Section 1 | See revised schedule information in Rev. 2 of the DPP |
| Section 2 | Supplement describes additional evaluation of alternatives. |
| Section 3 | February 17, 1998 version superseded by Rev. 2 of the DPP |
| Section 4 | Supplement describes additional data forwarded to MMS subsequent to February 17, 1998 |
| Section 5 | Supplement briefly assesses any impacts of scope changes and provides an updated analysis of the effects of project construction on water quality |
| Section 6 | Supplement updates |
| Section 7 | Supplement updates |
| Section 8 | Supplement updates |
| Section 9 | Supplement updates |

2. DEVELOPMENT ALTERNATIVES

Development alternatives for Liberty were identified as part of the conceptual engineering process. BPXA has prepared a more detailed discussion of these alternatives as described in a report submitted to MMS titled; "Liberty Field Development Alternatives, 4/24/98".

In 1999, BPXA retained Intec Engineering to provide a conceptual level comparison of offshore pipeline system alternatives for export of sales quality oil from Liberty. The purpose of the study was to provide additional information about subsea pipeline alternatives for use in the project Environmental Impact Statement.

3. PROJECT DESCRIPTION

The Project Description contained in the February 17, 1998 ER has been superseded by Revision 2 of the DPP.

4. AFFECTED ENVIRONMENT

At the time the February 17, 1998 ER was issued, BPXA and its contractors were in the process of preparing reports on field research conducted in 1997, and planning for field work to be conducted in 1998. Additional information that has been provided to MMS subsequent to issuance of the original ER is listed in Table 1. None of the additional background data collected revealed a need to alter project siting or design.

5. ENVIRONMENTAL CONSEQUENCES

This section describes the general environmental effects of engineering design and schedule changes to the Liberty Development Project, and also provides supplemental information about effects of project construction on water quality.

5.1 TWO YEAR CONSTRUCTION SCHEDULE

BPXA intends to construct the Liberty Project over two years, with gravel island construction starting in January Year 2 and pipeline construction in starting in January Year 3.

TABLE 1

ADDITIONAL INFORMATION SUBMITTED TO MMS IN SUPPORT OF LIBERTY DEVELOPMENT AND PRODUCTION PLAN AND ENVIRONMENTAL REPORT (AFTER FEBRUARY 17, 1998)

| DATE SUBMITTED | DESCRIPTION |
|----------------|--|
| April 14, 1998 | Chemical characterization of Liberty crude oil |
| April 14, 1998 | BPXA estimates of Liberty production data and estimated revenues from the Liberty project by year |
| April 22, 1998 | Field acoustical data collected while drilling the Liberty #1 Exploration Well, in a report: "Under Ice Drill Rig Sound, Sound Transmission Loss, and Ambient Noise Near Tern Island, Foggy Island Bay, Alaska, February 1997", prepared by Greeneridge Sciences and LGL Alaska Research Associates |
| April 22, 1998 | BPXA estimates of Alaskan employment from the Liberty Project |
| April 22, 1998 | A summary and overview of the contents of BPXA's February 13, 1998 Part 55 Air Quality Application for Liberty Project |
| April 27, 1998 | Additional analytic information characterizing the risk and nature of a spill from the products pipeline |
| April 30, 1998 | Field data and engineering analysis of the proposed shore crossing location, in a report: "Coastal Stability Analysis - liberty Pipeline Shore Crossing, December 1997", prepared by Coastal Frontiers Corporation |
| May 29, 1998 | Additional public geologic information in response to scoping comments |
| June 4, 1998 | Video tapes of 1998 ROV survey in Foggy Island Bay |
| June 4, 1998 | Background socioeconomic data and revenue forecasts in a report: "Liberty Development Project", May 1998, prepared by Northern Economics |
| July 13, 1998 | Data report: "Laboratory Testing to Determine Spill Related Properties of Liberty Crude Oil", prepared by SL Ross Environmental Research Ltd. June, 1998 |
| July 20, 1998 | Geotechnical data regarding pipeline route and island location, in report: "Geotechnical Exploration Liberty Development, North Slope, Alaska", prepared by Duane Miller & Associates on July 6, 1998. |

TABLE 1 (CONT'D)

ADDITIONAL INFORMATION SUBMITTED TO MMS IN SUPPORT OF LIBERTY DEVELOPMENT AND PRODUCTION PLAN AND ENVIRONMENTAL REPORT (AFTER FEBRUARY 17, 1998)

| | |
|---|--|
| July 27, 1998 | Results of Summer 1997 and Winter 1998 Boulder Patch Survey, in report: "Liberty Development 1997-1998 Boulder Patch Survey", prepared by Coastal Frontiers Corporation and LGL Ecological Research Associates, July, 1998. |
| August 26, 1998 | Field acoustical data collected in Summer 1997, in a report: "Underwater Acoustic Noise and Transmission Loss During Summer at BP's Liberty Prospect in Foggy Island Bay, Alaska Beaufort Sea", prepared by Greeneridge Sciences and LGL Alaska Research Associates |
| September 11, 1998 | Results of field vegetation site inspections at proposed mine site, shorecrossing pad, and pipeline tie-in September 11, 1998 Trip Report summarizing Wetland and Vegetation Information for Liberty EIS, prepared by LGL |
| September 30, 1998 | Background water and sediment sample data collected in winter 1998, in report: "Liberty Island Route Water/Sediment Sampling, March 28-29, 1998", prepared by Montgomery Watson |
| December 14, 1998 (in letter to Corps of Engineers) | Evaluation of effects of excess dredged material disposal in report: "Draft Section 103 Marine Protection, Research and Sanctuaries Act Dredged Material Disposal Site Evaluation dated November 1998", prepared by URS Greiner Woodward Clyde |
| January 6, 1999 | Assessment of Offshore Cultural Resources in report: "Liberty Cultural Resource Assessment, Foggy Island Bay in Steffanson Sound, Alaska", prepared by Watson Company, Inc. 1998. |
| July 15, 1999 | Effects of construction on Boulder Patch in report: "Liberty Development: Construction Effects on Boulder Patch Kelp Production", prepared by Ban et al, 1999. |
| November 1, 1999 | Analysis of pipeline design alternatives in report: "Pipeline System Alternatives - Liberty Development Project Conceptual Engineering", prepared by Intec Engineering, Inc. |

Project effects will be essentially the same as described in the Environmental Report (LGL et al. 1998); these effects will occur over two years rather than one. No new impacts on the environment will occur; the timing of some of the disturbances will occur in one or the other, or in both, construction years, as opposed to occurring only in one year.

Construction ice roads will be built over two winter seasons. In the first season, roads supporting island construction will be built, and in the second season, roads supporting pipeline construction will be built. With a two year construction schedule, marine mammal disturbance from heavy equipment usage during the construction and use of the ice road complexes will occur over two winters. With a two- rather than a one-season winter construction program, some additional disturbance of ringed seals and polar bears may result from the use of heavy equipment and the presence of human activities on nearshore and offshore ice over two winters instead of one winter. If polar bear den sites, seal breathing holes, or seal birthing lairs are identified in the project area during either year, BPXA will avoid these sites. Regardless of whether the Liberty Development is built over one or two years, ice road complexes are planned to be constructed annually throughout the production life of the development; thus the incremental effects from an additional year's construction season will be negligible.

As previously described in LGL et al. (1998), marine water turbidity levels will increase slightly due to the island and pipeline construction activities, potentially affecting the nearby Boulder Patch benthic communities. With the island construction occurring in year one and the pipeline construction in year two, these turbidity effects will extend over two years. Impacts of this construction are addressed in Ban et al. 1999.

With a two-year construction scenario, gravel removal at the Kadleroshilik River mine site will occur in two winter seasons, not one. Since gravel excavation and transport from the mine site will be limited to the winter season, no additional effects on birds or mammals that may use habitat at the mine site will occur. No additional acreage will be disturbed. Reclamation of the mine site will be conducted after all gravel removal activities have been completed.

With movement of construction vehicles and supplies extended over two seasons, there will be some additional potential for small fuel spills. However, spills are very unlikely given the fuel handling and transport procedures practiced by industry on the North Slope. Fuel and other contaminant safe handling practices will be followed throughout the two-year construction season and throughout the operational life of the Liberty Development.

The overall effects of a two-year construction schedule will be of little additional consequence to the environment or biological resources in this region, since during each year a different area will be affected (island site versus pipeline corridor). There will be cumulative effects over two successive seasons rather than one, but the net increase in impact on the environment will be negligible.

5.2 DETAILED MINING PLAN

A detailed gravel mining and rehabilitation plan was developed subsequent to submittal of the February 1998 Environmental Report. The final plan was based on project gravel needs

and site investigation. The surface acreage in the mine site area is approximately 53 acres, which represents a "planning footprint". Within the 53± acres, it is estimated that approximately 31 acres will be directly affected by mining to support project development. The remaining 22± acre "reserve area" is available to support temporary mining activities (stockpiling on an ice pad) and future emergency gravel supply.

Phased development of the mine is currently planned, with the proposed 31± acre excavation area developed as two cells, to match the two year project construction schedule. One cell of the mine would be developed each winter construction season, with gravel extracted and site rehabilitation initiated by breakup of that year. Mining plans for the primary excavation area, as well as for the reserve area, are similar.

The mine site is in a region of riverine barrens and flood plain alluvium. From aerial photo interpretation and a site visit, it is estimated that the 53 acre mine site area is about 40 percent dry dwarf shrub/lichen tundra, 10 percent dry barren/dwarf shrub, forb grass complex, and 50 percent river gravels. The site investigation showed evidence of grazing by caribou and muskoxen.

5.3 CAMP BARGE DURING CONSTRUCTION

BPXA is considering using a barge as a temporary construction camp adjacent to Liberty Island to support module installation. The camp barge will provide more space for personnel and supplies, thus increasing human activities at the island during that open water season. The barge and associated human presence will generate waste that must be handled and transported away from the site, and this may also increase the potential for barge-to-island spills of contaminants. These effects are expected to be minimal and restricted to the open water season of Year 3 only (and Year 4 if the barge is overwintered). If an intense storm develops when the barge is moored to the island, there is a potential for accidental spills of materials on the barge as it is buffeted by seas or as the barge is moved to the lee of the island.

The camp barge will provide lodging and work space for personnel during facilities installation on the island. This will reduce the frequency and number of shore-to-island trips of vessels and aircraft that would be required to transport people and supplies to the Liberty Island construction site. This would reduce the disturbance to the region's wildlife from helicopter and crew boat travel, reduce the potential for contaminant spills from boat and helicopter activity, and reduce the potential for accidents associated with vessel and aircraft movement.

5.4 INCREASED TRANSPORTATION LEVELS

BPXA has revised upward the original estimates of crew boat, barge, helicopter, and vehicle over-ice transport activities associated with construction and operation of the Liberty Development (Table 4-2, DPP). In addition, diesel fuel supplies for permanent operations will be delivered by barge during summer and possibly by ice road during winter. No impacts on the environment that have not already been described (LGL et al. 1998) will occur from these

revised traffic forecasts. Increases in vessel, vehicle, and aircraft traffic will increase the potential for accidents and contaminant spills. Standard North Slope industry practices for fueling and transport of fuels, lubricants, and other potential contaminants will minimize spills. More frequent on-ice vehicle activity may increase disturbances to ringed seals and polar bears, and more frequent helicopter overflights and vessel trips to the island may increase disturbance to marine mammals, waterfowl, and marine and coastal birds.

5.5 USE OF HYDRAULIC DREDGING FOR PIPELINE TRENCH EXCAVATION AND CLEANOUT

Hydraulic dredging equipment may be employed to improve precision of the trenching for pipeline installation during the final stages of trenching to clean out the bottom of the trench and to smooth the grade upon which the pipe string will be laid. The hydraulic dredging equipment is fitted to a backhoe and is operated from the ice surface concurrent with placement of the pipeline in the trench. Sediment pumped from the trench will be piped back into or adjacent to the trench. More information regarding the effects of pipeline construction on water quality is provided in Ban et al. 1999.

5.6 AUTOMATIC SHUTOFF VALVE AT SHORE CROSSING

An automatic shutoff valve will be fitted in the oil pipeline at the shore crossing. The option of using a vertical loop will be considered in final design. The original design included a manual shutoff valve at the shore crossing location. In the event of an offshore pipeline rupture, an automatic valve would close and limit the size of the oil spill. The automatic valve (versus a manual valve) will reduce the volume of crude oil spilled into the environment from the offshore segment of the pipeline by about 1020 barrels, under a complete pipeline rupture scenario. Less crude oil would be spilled into the marine environment, thereby reducing impacts on marine organisms and habitats. The use of a vertical loop is also expected to reduce the size of a spill versus the size that could be expected if a manual valve were in place.

5.7 GRAVEL BAGS ON PIPELINE BEFORE BURIAL

After excavation of the pipeline trench and placement of the pipe string, BPXA will place gravel-filled geotextile bags over the top of the pipeline in the trench. A backhoe fitted with specially designed tongs will be used to place the bags so as to not rupture the fabric during installation. Spoil removed from the trench will then be placed back into the trench over the pipeline string, completely burying the gravel-filled bags at depth. There will be no additional environmental effects from using gravel-filled bags to anchor the pipe string.

5.8 INCREASED DIESEL FUEL STORAGE ON ISLAND

BPXA has calculated that approximately 21,000 barrels of diesel fuel will be stored temporarily on the Liberty Island during construction. This increased volume of diesel is required

to meet demands from drilling and construction activities; a much smaller volume (3,000 barrels) will be needed after construction. With increased diesel fuel storage comes increased potential for accidents and spills. BPXA has recognized this risk in its spill response planning, and will implement best management practices for fuel handling on the island to minimize the potential for spills of diesel fuel.

5.9 INCREASED CRUDE OIL PRODUCTION OPTION

BPXA is considering increasing production of crude oil from the field to a peak of 75,000 barrels per day. This increase in production would not increase any discharges permitted under the NPDES nor would this level of production increase other wastes or emissions. No new or additional environmental effects would occur due to an increase in crude oil production.

5.10 INCREASED SIZE OF ISLAND FOOTPRINT

The Liberty island has a design bottom dimension of 635 ft x 970 ft (as opposed to the original design footprint of 630-670 ft x 960-1000 ft). The actual island footprint is likely to be larger than the design bottom dimensions. During the process of construction, gravel will be dropped through the water column to build the island structure up from the seafloor. In this process, not all gravel will fall precisely within the design footprint. To accommodate this construction uncertainty, BPXA has identified a construction footprint of about 835 feet by 1170 feet; this footprint includes an extra 100 feet around the perimeter of the design island bottom dimensions.

This area is slightly greater than the original low estimate, but the additional benthic habitat covered by gravel materials is negligible. Under-ice surveys of the benthic environment in April 1998 confirmed that no Boulder Patch habitat occurs at the island site.

5.11 ELIMINATION OF ISLAND STORMWATER DISCHARGE

Storm water collected on the Liberty Island will be injected into the waste disposal well. Environmental effects of the previously-described stormwater discharge into the marine environment will be eliminated.

6. MITIGATION MEASURES

The February 17, 1998 Environmental Report contains a comprehensive list of mitigation incorporated into project planning, design, construction, and operation. Scope changes identified after submittal of that report (as described in Revision 1 of the DPP) resulted in further mitigation of project impacts. These mitigation measures include:

- elimination of discharges associated with deck drainage

- placing an automated valve or a vertical loop at the pipeline shorecrossing pad (versus the originally proposed manual valve). Use of an automated valve at this location causes an estimated decrease of about 1,020 barrels from a leak resulting from a complete rupture of the offshore oil pipeline with a manual valve
- possible use of construction camp barge would reduce levels of helicopter and vessel traffic needed to support construction
- two season gravel mining plan incorporates rehabilitation measures
- proposed location of disposal site for any excess materials excavated from pipeline trench was selected in consultation with agencies to minimize impacts to marine environment
- commitment to continue consultation with resource agencies on means to reduce impacts of overflights
- supplemental leak detection system (LEOS)

7. COORDINATION AND CONSULTATION

BPXA will continue to involve representatives of the communities in the planning phase of the Liberty Development Project. BPXA managers will meet with the communities periodically in workshops on project specifics such as project design and engineering, and oil spill response planning. The purpose of these meetings will be to provide updated information on the project and to discuss, in greater detail, specific issues.

In ongoing consultation, BPXA will hold community workshops in Nuiqsut, the community closest to the project, and in Kaktovik and Barrow, two other communities potentially affected by the project. BPXA will also coordinate with other North Slope communities. The schedule of the workshops is to be worked out between community leaders and BPX.

Issues to be discussed in the workshops will include:

- Oil spill prevention and contingency planning.
- Island design, pipeline integrity and leak detection.
- Potential marine mammal disturbance. Disturbance to bowhead whales during the fall migration is of particular concern to local residents. BPXA will be prepared to answer questions and discuss marine mammal disturbance issues at these meetings.
- Employment and business opportunities.

BPXA will publish informational newsletters on each of these topics periodically during the year, supplemented with video materials and radio programs.

BPXA will organize a program to incorporate the knowledge of village elders, whaling captains and subsistence hunters into project planning. The program will primarily involve Nuiqsut, the closest community to the Liberty project, but may include, if necessary, Kaktovik and Barrow.

During construction, BPXA will involve community residents and organizations, through the Alaska Eskimo Whaling Commission, in any required monitoring of development activities for potential marine mammal and wildlife impacts. Conflict avoidance agreements (extensions of existing agreements) will be negotiated with the Alaska Eskimo Whaling Commission and the Whaling Captains Associations of Nuiqsut and Kaktovik, consistent with those achieved in the past.

BPXA will involve community residents and organizations in oil spill prevention and response, through Alaska Clean Seas, the industry North Slope spill cooperative. This will include involving village residents in shoreline sensitivity assessments and the organization of village response teams to assist in the event of a spill. This commitment will require training and assistance by the village teams in annual spill drills held in the Prudhoe Bay vicinity.

BPXA will involve community residents and local institutions and organizations in development and implementation of a training program in cultural and environmental awareness for BPXA and contractor employees involved in Liberty development and subsequent production.

8. LIST OF PREPARERS

This overall document has been prepared by BPXA, with assistance in preparation of Section 5 provided by LGL Alaska Research Associates, LTD and by URS Greiner Woodward Clyde.

9. REFERENCES CITED

- Ban, Suzanne M., Colonell, J., Dunton, K., Gallaway, B., and Martin, L. Liberty Development: Construction Effects on Boulder Patch Kelp Production. Report for BP Exploration (Alaska) Inc., May 27, 1999, Anchorage, AK.
- Coastal Frontiers Corporation and LGL Ecological Research Associates, Inc. 1998. Liberty Development 1997-98 Boulder Patch Survey. Final Report. Report for BP Exploration (Alaska) Inc., Anchorage, AK.
- Duane Miller and Associates, Geotechnical Exploration Liberty Development, North Slope, Alaska, July 6, 1998, Anchorage, AK.
- Intec Engineering Inc. Pipeline System Alternatives - Liberty Development Project Conceptual Engineering, November 1, 1999. Prepared for BP Exploration (Alaska) Inc., Anchorage, Alaska. LGL Alaska Research Associates, Inc., Woodward-Clyde Consultants, and Applied Sociocultural Research. 1998. Liberty Development Project Environmental Report. Report for BP Exploration (Alaska) Inc., Anchorage, AK.

Liberty Environmental Report

URS Greiner Woodward Clyde. Section 103 Marine Protection, Research and Sanctuaries Act
Dredged Material Disposal Site Evaluation (Draft Report Version 3.0). Report for BP
Exploration (Alaska) Inc., November 1998, Anchorage, AK.
