

F EIS

AMS Cope
6

HERRING BAY EXPERIMENTAL AND MONITORING STUDIES

FINAL STATUS REPORT

RESTORATION PROJECT NO. 102

Draft - Report still
under review.

**School of Fisheries and Ocean Sciences
University of Alaska Fairbanks
Fairbanks, AK 99775-1090**

October 1993

TABLE OF CONTENTS

PROJECT PARTICIPANTS	iii
EXECUTIVE SUMMARY	1
CHAPTER 1. GENERAL INTRODUCTION AND SITE SELECTION	3
Site Selection	4
CHAPTER 2. ALGAL STUDIES	13
INTRODUCTION TO ALGAL STUDIES	13
ALGAL METHODS	13
<i>Fucus</i> Population Dynamics	13
<i>Fucus</i> Reproductive Potential and Egg Viability	14
Fertility of Floating <i>Fucus</i>	15
<i>Fucus</i> Germling Growth and Survival	15
Growth of Established <i>Fucus</i> Plants	17
<i>Fucus</i> Egg Density	18
Statistical Methods	18
ALGAL RESULTS	19
Population Dynamics	19
Reproductive Potential and Egg Viability	22
Fertility of Floating <i>Fucus</i>	23
Germling Growth and Survival	23
Growth of Established <i>Fucus</i> Plants	24
<i>Fucus</i> Egg Density	25
DISCUSSION OF ALGAL STUDIES	25
CHAPTER 3. INVERTEBRATE STUDIES	62
INTRODUCTION TO INVERTEBRATE STUDIES	62
INVERTEBRATE METHODS	63
Population Dynamics of Selected Invertebrates	63
Sediment Hydrocarbons	63
Barnacle and <i>Fucus</i> Recruitment	64
Oiled Rock/Tile Study	64
Mussel Recruitment	66
Settlement Patterns	66
Grazing By Limpets	66
<i>Tectura persona</i> and <i>Lottia pelta</i> Grazing Study	68
INVERTEBRATE RESULTS	69
Population Dynamics of Selected Invertebrates	69
Sediment Hydrocarbons	70
Barnacle and <i>Fucus</i> Recruitment	70
Oiled Rock/Tile Study	72
Mussel Recruitment	73
Settlement Patterns	74
Grazing By Limpets	74
<i>Tectura persona</i> and <i>Lottia pelta</i> Grazing Study	75
INVERTEBRATE DISCUSSION	76
CHAPTER 4. GENERAL DISCUSSION	192
Physical Differences Among Sites	192
Community Organization	192
Effects of the Oil Spill	194
Recovery Processes	194
Application to other EVOS Impacted Areas	196
To Clean or Not to Clean	197
Recommendations	197
REFERENCES	200

PROJECT PARTICIPANTS

INVERTEBRATES

Raymond C. Highsmith
Institute of Marine Science
School of Fisheries and Ocean Sciences
University of Alaska Fairbanks
Fairbanks, Alaska 99775-1080

Andy J. Hooten
Coastal Resources Assoc. and
Institute of Marine Science
School of Fisheries and Ocean Sciences
University of Alaska Fairbanks
Fairbanks, Alaska 99775-1080

BIOMETRICS

Lyman McDonald
WEST, Inc.
1402 S. Greely Highway
Cheyenne, Wyoming 82007

Dale Strickland
WEST, Inc.
1402 S. Greely Highway
Cheyenne, Wyoming 82007

Wallace P. Erickson
WEST, Inc.
1402 S. Greely Highway
Cheyenne, Wyoming 82007

ALGAE

Michael S. Stekoll
Juneau Center, Fisheries and Ocean Sciences
School of Fisheries and Ocean Sciences
University of Alaska Fairbanks
11120 Glacier Highway
Juneau, Alaska 99803

Peter van Tamelen
Juneau Center, Fisheries and Ocean Sciences
School of Fisheries and Ocean Sciences
University of Alaska Fairbanks
11120 Glacier Highway
Juneau, Alaska 99803

Larry Deysher
Coastal Resources Associates
1185 Park Center Drive, #A
Vista, California 92083

EXECUTIVE SUMMARY

Intertidal studies established in 1990 in Herring Bay, Prince William Sound have continued through the 1992 season. Examination of populations of the dominant intertidal alga, *Fucus gardneri*, revealed that larger plants were removed from the intertidal in affected areas. Where *Fucus* cover was reduced by the oil or clean-up activities, there was often an increase in the abundance of ephemeral algae. Lower abundances of reproductive *Fucus* plants at oiled sites also resulted in fewer *Fucus* eggs settling on those sites. At oiled sites, desiccation and heating are severe due to the lack of a protective *Fucus* canopy, leading to low recruitment of *Fucus* germlings. The growth rate of established *Fucus* plants was greater at oiled sites, probably due to reduced intraspecific competition from lower densities of large plants at oiled sites. Measurements of growth rates indicate it takes *Fucus* plants about three years to reach reproductive status. To develop a thick *Fucus* canopy in the high intertidal, larger plants must be present both to seed an area with eggs and to protect germlings from desiccation stress. Canopies expand outward from the edge as young plants are protected by nearby larger plants.

The limpet, *Tectura persona*, continued to show lower densities at oiled sites than control sites, with differences most pronounced in the upper and mid-intertidal. Differences in *T. persona* densities increased between most control and oiled site pairs in 1991 compared to 1990. In the lower intertidal zone of coarse-textured sites, however, two of the oiled sites now have higher densities of *T. persona* than their matched controls. Densities differences of the limpet, *Lottia pelta*, were also greater between most matched control and oiled sites in the mid-intertidal during 1991 compared to 1990, but in 1992 this species appears to be recovering more rapidly than *T. persona* at most sites. The periwinkle, *Littorina sitkana*, was less dense in the mid- and lower intertidal over the study period at four of the seven oiled sites compared to controls. Other invertebrates studied generally occurred in low densities in Herring Bay, and few differences between oiled and control sites were detectable.

Initially, barnacle recruitment was lower in quadrats on tar-covered rocks, compared to scraped quadrats, but differences disappeared at most sites over time. Barnacles have successfully colonized both oiled and non-oiled substrates so that by 1992 there were no differences in abundance of surviving adults between treatments. *Fucus* germlings and filamentous algae continued to have lower densities and percent cover on oiled than non-oiled substrates. Exceptions occurred on oiled plots when barnacle tests provided suitable substrate for *Fucus* colonization.

Results of the several Herring Bay studies have been incorporated into an interaction web to elucidate potential oil spill effects on community dynamics. Direct and indirect effects of the oil spill were identified and recovery of intertidal populations relative to various interactions were evaluated.

Recovery is taking place in lower and middle intertidal zones and normal community interactions are returning. The upper intertidal, however, continues to exhibit damage and recovery of this zone may take an additional 2-5 years.

CHAPTER 1. GENERAL INTRODUCTION AND SITE SELECTION

Crude oil spilled from tankers can directly affect shore organisms in two ways. Physically, the oil can smother organisms, resulting in death or limiting acquisition of resources such as food, light, or nutrients. Because of the toxicity of oil the growth rates of organisms, reproductive potentials, and survivorship can all be reduced. There may be additional effects of shoreline cleaning methods which can negatively effect intertidal plants and animals, with the magnitude of the impact varying with the intensity of the effort and the method utilized. Finally, due to reductions in the abundances of some organisms, other organisms not directly affected by an oil spill but which interact strongly with the damaged populations may also be influenced.

In March, 1989, the Exxon Valdez ran aground on Bligh reef in northeastern Prince William Sound spilling 11 million gallons of North Slope crude oil. The spilled oil was transported by currents and prevailing winds to the south and west, impacting the shorelines of southwest Prince William Sound. Prior to the oil spill, knowledge of intertidal communities in the spill region was restricted to a few sites or general characterizations of community structure over a wider area of Prince William Sound (Feder and Bryson-Schwafel 1988; Rosenthal *et al.* 1982).

Extensive cleanup operations were conducted throughout Prince William Sound to remove oil from impacted shorelines. Various shoreline treatments were used, such as hand cleaning, washing with varying water pressures and temperatures, repeated washings, and wide scale use of bioremediation. The treatment activities contributed to the death or removal of invertebrates and algae from oiled shorelines. Hot water, high pressure washing conducted from OMNI and MAXI barges was applied to many sites and clearly contributed to removal of organisms (Lees *et al.* 1993).

In late 1989, a series of monitoring programs were initiated to document the effects of the oil spill on intertidal biota throughout the impacted area (Highsmith *et al.* 1993). The goal of this Coastal Habitat Injury Assessment (CHIA) project was to document effects on various organisms due to the spilled oil and subsequent clean-up. In 1990 experimental studies were begun in Herring Bay, Knight Island, Prince William Sound, which were designed to compliment these overall monitoring programs by experimentally assessing intertidal community dynamics and mechanisms of recovery. This experimental approach went beyond simple species inventories, allowing a more comprehensive assessment of the Exxon Valdez Oil Spill (EVOS) impacts on physical and biological interactions mediating community structure. The manipulative experiments were designed to evaluate the strength of important species interactions and the role of physical factors in community structure.

Site Selection

Since no pre-spill data existed for Herring Bay, sites for these studies were selected by pairing sites from oiled and unoiled areas in the bay. The use of post-spill comparisons among control and impacted sites has been a common approach in assessing the effects of oil, and only in a few cases have pre-spill baseline data been available (Chan 1974; Jackson *et al.* 1981; Crothers 1983). A major assumption of any study where the sites are chosen after a perturbation is that the control sites represent pre-disturbance conditions. In the present case, the intertidal communities at the control sites were assumed to be similar to those at the oiled sites before the spill.

The southeast corner of Herring Bay retained ice until early April 1989, essentially excluding the oil slick. Therefore, control sites were restricted to the southeastern corner of the Bay. To minimize differences in exposure to wind and wave energy, most oiled study sites were established in the southwestern section of Herring Bay. Figure 1.1 shows the locations of all the oiled and control sites used in the studies presented here. The general procedure for selecting sites was to identify a workable area in the control section of the bay and then find an oiled area which resembled the control site as closely as possible. Site pairs were matched in as many physical characteristics as possible. The criteria used for matching sites included similarity in substrate composition, slope, directional and solar aspect, wave exposure, and, occasionally, the presence of patchily distributed organisms. Table 1.1 lists all pairs of sites and gives some of their physical characteristics and possible shoreline treatments.

Despite attempts to minimize physical differences between oiled and control sites, some differences remained. Control sites were more often subjected to fresh water influence because of large streams entering that portion of the Bay (Fig. 1.1). Salinity and temperature measurements at the water surface and at 1 meter depth were recorded weekly at oiled and control sites in 1990 and 1991, and twice during 1992. Differences in water temperature were occasionally detected between oiled and control sections of the bay (Figs. 1.2, 1.3). These differences, however, were small, within 1°, compared to seasonal and weekly fluctuations of up to 10°. For 57% of the sampling dates, the surface salinity was significantly higher on the oiled side of the bay than on the control side (Figure 1.2). The salinity at 1 meter did not show as many differences as the surface salinity, but differences were detected on twelve of the sampling dates (Figure 1.3). Again, the differences between oiled and control areas were minor relative to seasonal and weekly fluctuations. Fresh water tends to depress species richness and reduce densities of some intertidal invertebrates and possibly algae, compared to areas where salinity is more constant (Barnes 1980), the small differences in Herring Bay would probably only be biologically significant, if at all, in the uppermost intertidal zone.

Physical disturbance seems to have a greater impact on intertidal shorelines at control sites in Herring Bay. The control site, 2333C, had a greater number of rebar stakes upturned and missing from all three tidal levels compared to its matched oiled site, 2333X (Table 1.2). In 1992, 2333C again had several rebar stakes disturbed where the oiled site remained intact. The source of this disturbance is unknown, but ice scouring is a strong possibility. Ice has been observed in the southeastern section of the bay in spring 1991 and can be seen in aerial photographs taken in spring 1989 and 1990. Ice has not been observed at any time in the southwestern section of the bay.

Due to both freshwater and ice scouring, the control sites in Herring Bay would be expected to have lower population densities than the oiled sites. This expectation means that our results probably underestimate the actual differences. Observed lower densities of plants or animals at oiled sites compared to control sites would indicate reductions first to a level equal to control levels in addition to the observed reductions to below control levels. In addition, some decreases in plant or animal populations may have occurred at oiled sites but were not detected in our studies since the reductions were to levels equal to those of control sites.

Since our sites were not selected randomly, but were hand picked, the generality of our results is limited to the specific sites we have studied. Attempts to generalize the effects of the EVOS over the entire spill area, including Herring Bay, have been made elsewhere (Highsmith et al. 1993), and the data collected by the present studies and the CHIA studies are directly comparable due to similar sampling designs. For these reasons, we have not attempted to statistically generalize our results beyond the sites studied. More generalized statistical tests would only allow us to generalize over the sites studied and not over Herring Bay or Prince William Sound. We do, however, compare our population dynamic results with those of the CHIA studies to show generalities of our results. Compared with most other experimental ecological work, our studies are well replicated. Not only do we have adequate replication within site pairs, which is the equivalent of most good ecological studies, but we have replicated the experiments over space. This spatial replication is rarely performed by other studies, yet their results are often applied over much broader geographic areas with little or no evidence in support of generalizations.

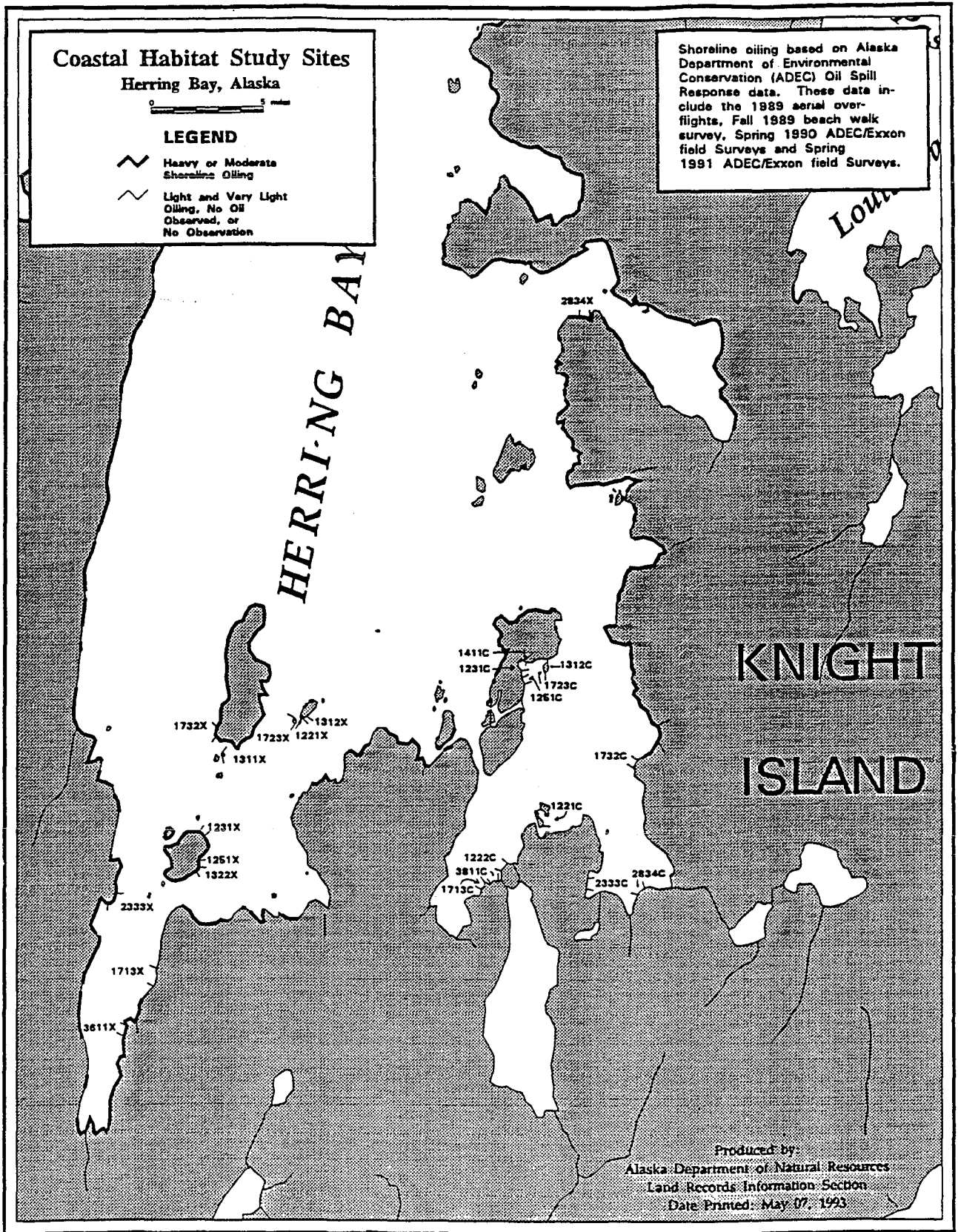

Figure 1.1a. Map of the study area showing the locations of all of the study sites. The shoreline which is in the unoiled category includes shorelines in which oiling level may not have been recorded, so that some shorelines will appear "unoiled" on the map even though they may have been heavily oiled.

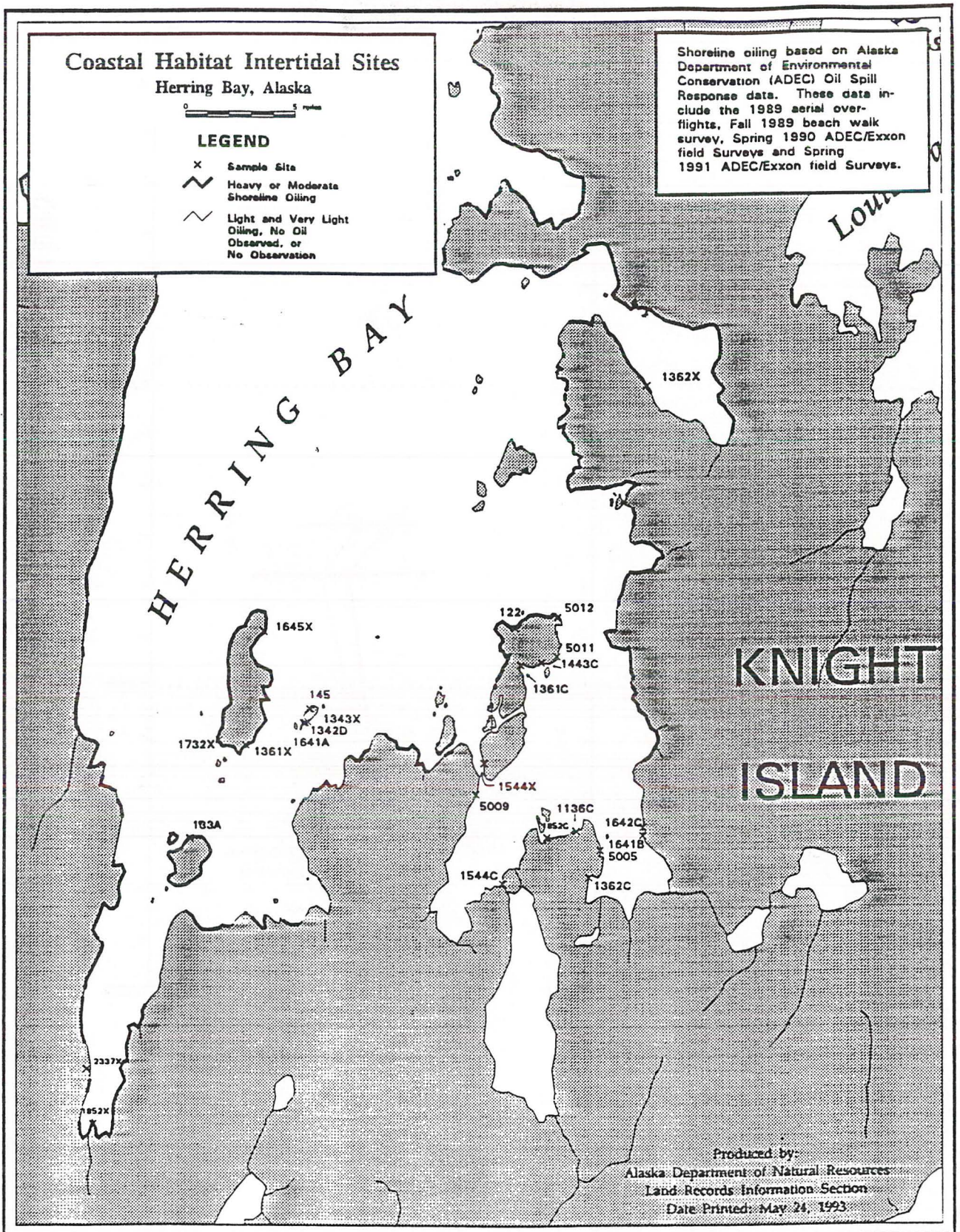

Figure 1.1b. Map of the study area showing the locations of all of the study sites. The shoreline which is in the unoiled category includes shorelines in which oiling level may not have been recorded, so that some shorelines will appear "unoiled" on the map even though they may have been heavily oiled.

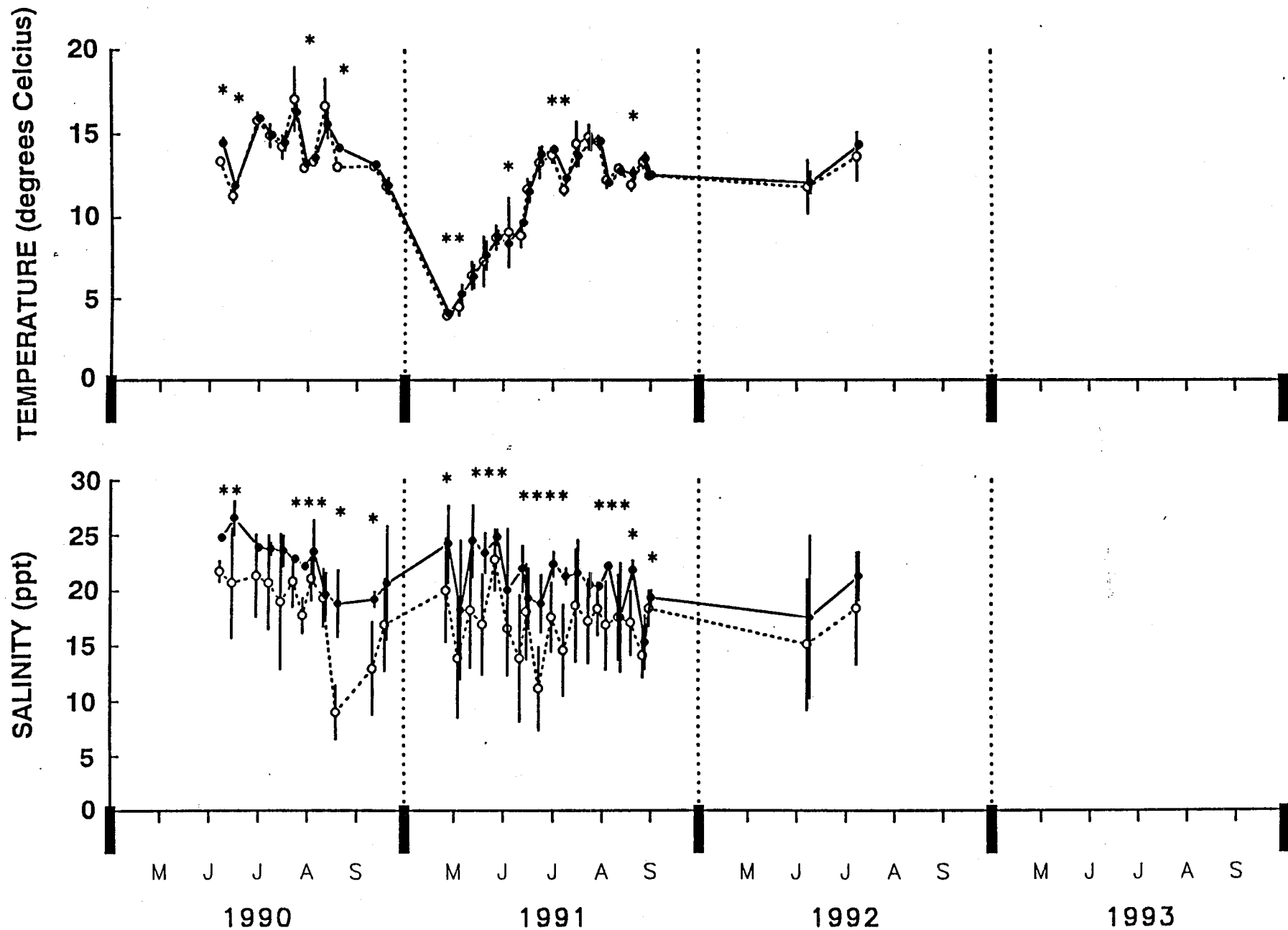

Figure 1.2. The temperature and salinity at the water surface at oiled and control areas of Herring Bay. Error bars represent one standard deviation, and asterisks indicate statistical differences detected using t-test. The layout is the

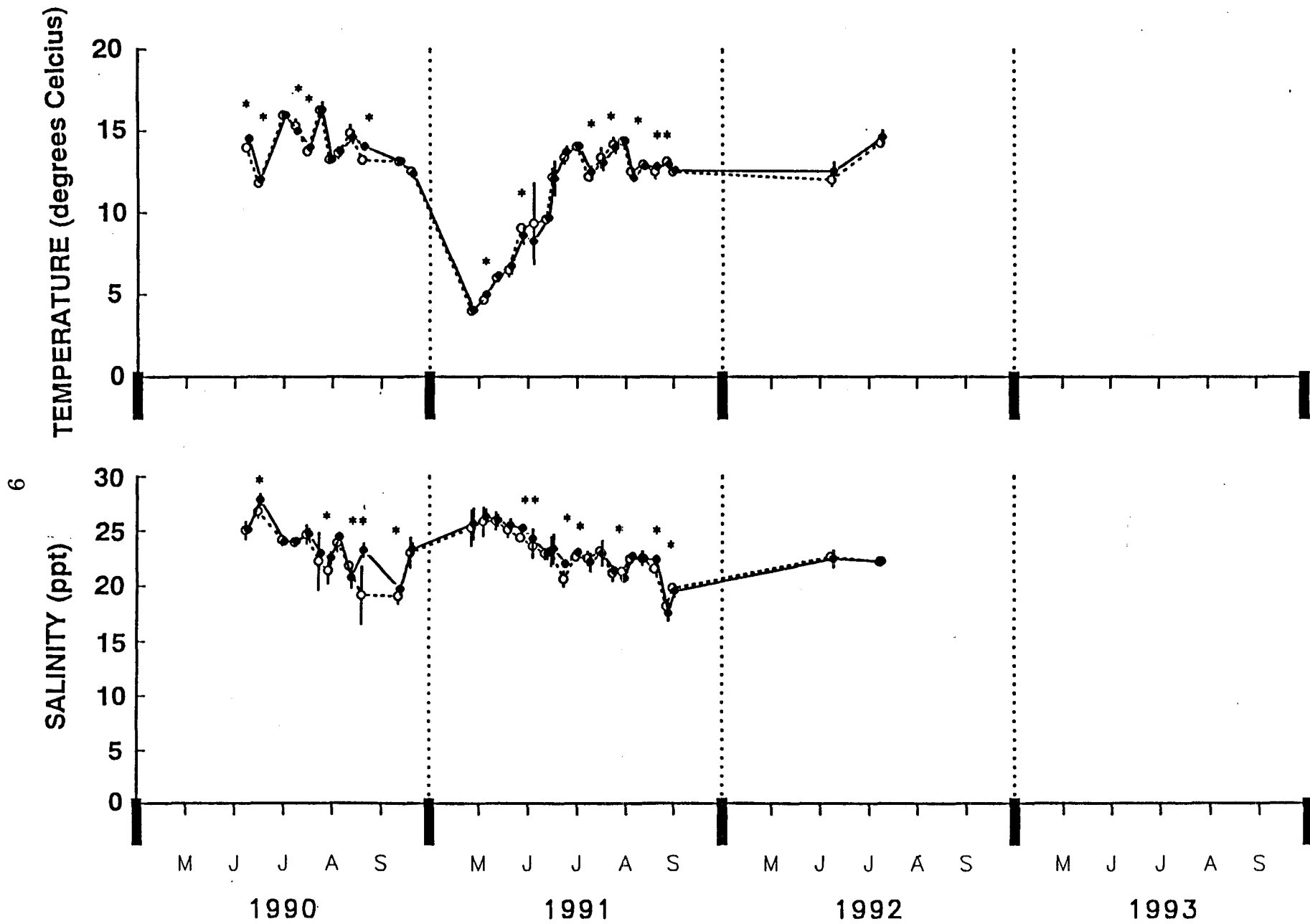

Figure 1.3. The temperature and salinity at 1 meter depth at oiled and control areas of Herring Bay. Error bars represent one standard deviation, and

Table 1.1. Characteristics of study sites including the length, magnetic orientation, slope, oiling level, and probable cleanup treatment applied. The cleanup treatments used were OMNI=Omni boom, BIO=bioremediation, HWHP=Hot Water High Pressure, and HWLP=Hot Water Low Pressure. The studies done at each study site are also indicated by the following codes: PDX=Population Dynamics, RX=Rock Exchange, GR=Growth of Fucus, ED=Relative Fucus Egg Density, LC=Limpet Caging, GGS=Germling Growth and Survival, LG=Limpet Grazing, BR=Barnacle Recruitment, and MD=Mussel Density. There were three habitats studies were carried out in: SR=Sheltered Rocky, VW=Vertical Walls, and CT=Coarse Textured. The Exxon segment number is also given.

Site	Habitat	Studies	Length(m)	Orientation	Slope	Oiling level	Cleanup treatment	Segment
1136C	SR	PDX ¹	35	330	30	none	no treatment	KN5006
1221C	SR	RX GR ED	105	40	19	none	no treatment	KN5006
1221X	SR	RX GR ED	20	45	26	heavy, moderate	OMNI, HWHP, BIO	KN0145
1222C	SR	RX ED	40	350	23	none	no treatment	KN5007
1322X	SR	RX ED	16	90	21	heavy, moderate	OMNI, HWHP, BIO	KN0133
1231C	SR	PDX LC ED	55	45	23	light, very light	no treatment	KN5012
1231X	SR	PDX LC ED	32	50	21	heavy, moderate	OMNI, HWHP, BIO	KN0133
1251C	SR	LC GGS	22	350	31	light	no treatment	KN5011
1251X	SR	LC GGS	29	60	23	heavy, moderate	OMNI, HWHP, BIO	KN0133
1312C	SR	LG ED	34	100	18	light	no treatment	KN5011
1312X	SR	LG ED	20	118	20	heavy, moderate	OMNI, HWHP, BIO	KN0133
1342D	SR	BR	3	115	90	heavy, moderate	OMNI, HWHP, BIO	KN0133
1641A	SR	BR	3	260	90	heavy, moderate	OMNI, HWHP, BIO	KN0133
1641B	SR	BR	--	225	90	very light	no treatment	KN5004
1642C	SR	BR	--	225	90	very light	no treatment	KN5004
1443C	SR	BR	--	--	90	light	no treatment	KN5011
1343X	SR	BR	--	115	90	heavy. light	HWLP	KN0145
1361C	SR	MD	27	60	--	light	no treatment	
1361X	SR	MD	37	110	--	heavy, moderate	OMNI, HWHP, BIO	KN0133

Table 1.1. Continued.

Site	Habitat	Studies	Length(m)	Orientation	Slope	Oiling level	Cleanup treatment	Segment
1362C	SR	MD	27.5	78	--	very light	no treatment	
1362X	SR	MD	23	--	--	moderate, light	no treatment	KN0133
1411C	SR	LG ED GGS	22	130	21	light	no treatment	KN5011
1311X	SR	LG ED GGS	15	55	26	heavy, moderate	OMNI, HWHP, BIO	KN0133
1544C	SR	BR	--	--	90	none	no treatment	KN5007
1544X	SR	BR	--	--	90	light	no treatment	KN5001
1645X	SR	BR	--	315	90	heavy, moderate	OMNI, HWHP, BIO	KN0133
1713C	SR	LG GGS	45	275	36	none	no treatment	KN5007
1713X	SR	LG GGS	39	250	40	moderate, light	OMNI, HWLP	KN0127
1723C	SR	RX GR ED	35	270	15	light, very light	no treatment	KN5012
1723X	SR	RX GR ED	29	230	23	heavy, moderate	OMNI, HWHP, BIO	KN0145
1732C	SR	PDX	38	260	27-51	light, very light	no treatment	KN5002
1732X	SR	PDX	42	290	28-37	heavy, moderate	no treatment	KN0133
1746X	SR	BR	4.5	270	90	heavy, moderate	no treatment	KN0133
1838C	SR	PDX ¹	9.5	260	31	light	no treatment	KN5006
1852C	SR	LC	34	330	25	none	no treatment	KN5006
1852X	SR	LC	41.5	355	33	heavy, moderate	OMNI, HWHP	KN0129
3811C	VW	PDX LG	24	305	90	none	no treatment	KN5007
3611X	VW	PDX LG	33	255	90	moderate	OMNI	KN0128
2333C	CT	PDX	51	60	16	very light	no treatment	KN5004
2333X	CT	PDX	42	95	18	moderate	OMNI, HWHP	KN0131
2337X	CT	PDX	55	110	14	moderate, light	OMNI, HWLP, BIO	KN0130
2439X	CT	PDX	--	190	17	moderate	BIO	KN5000
2834C	CT	PDX	37	270	14	very light	no treatment	KN5004
2834X	CT	PDX	30	290	14	moderate	OMNI, HWLP	KN0121

Table 1.2. The number of plots in the 2333C/2333X site pair with disturbed rebar stakes following the winters of 1991 and 1992 at three tidal levels (MVD). The maximum number of plots per category was six.

MVD	CONTROL		OILED	
	1991	1992	1991	1992
1	4	2	5	0
2	6	2	2	0
3	6	5	0	0
TOTAL	<u>16</u>	<u>9</u>	<u>7</u>	<u>0</u>

CHAPTER 2. ALGAL STUDIES

INTRODUCTION TO ALGAL STUDIES

In Herring Bay, intertidal habitats are dominated by the alga, *Fucus gardneri* (Silva). This perennial brown alga occurs at all tidal levels. It is well suited to study as all phases of its simple life cycle are easily observed in the field or lab. A single plant releases both eggs and sperm which fuse to form a zygote. Zygotes travel to the substrate in a thick mucus released from the receptacles of adult plants. After settling, zygotes begin dividing and grow into germlings and eventually adult plants.

This study assessed the damage to populations of *Fucus* and other algae by the *Exxon Valdez* oil spill. The goal was to ascertain how the oil spill has affected the various life history stages of *Fucus* and to detect changes in abundance of *Fucus* as well as other algae found in the study area. Factors limiting or enhancing the recovery of *Fucus* have been identified and investigated, and potential recovery monitored.

ALGAL METHODS

Fucus Population Dynamics

The population structure of *Fucus* was monitored at five pairs of control and oiled sites, including 3 sheltered rocky and 2 coarse textured site pairs. Each site had 6 permanently marked, randomly placed quadrats (20x50 cm) in each of three tidal levels, giving a total of 18 quadrats per site. At each site, six transect heads were located along the base of the *Verrucaria* zone, approximately at mean higher high water. The length of the site was measured and divided by six, giving a segment length. The segment length was then multiplied by a random number (0-1.0) after subtracting the quadrat width (20 cm) from the segment length. Adding the quadrat width to the new number gave the location of the first transect head. Each of the subsequent transect heads were located by adding the segment length to the location of the previous transect head. The upper right corner of each quadrat was located by measuring the length of the transect at one meter of vertical drop (MVD), subtracting the length of the quadrat (50 cm), and multiplying by a random number. This was done for all three MVDs on each transect. The same random number was used for all MVDs on a given transect. A different number was generated for each transect.

The size-frequency distribution of *Fucus* was determined in each quadrat by measuring the length of all visible *Fucus* plants to the nearest 0.5 cm without removing plants from the substratum. Each plant was classified into one of six reproductive categories and one of five general condition categories. The six reproductive categories were 1) non-reproductive, 2) slightly swollen receptacles with evident conceptacles present, 3) swollen receptacles with light conceptacles

present, 4) fully swollen receptacles with dark conceptacles and no mucus present, 5) fully swollen receptacles with dark conceptacles and mucus evident, and 6) receptacles depleted and decaying. The five condition classes were 1) plant with at least some undamaged blades, 2) stipe only with no blades and no regrowth, 3) stipe only with no normal blades but regrowth from damaged tissue evident, 4) holdfast only with no stipe or blades, and 5) holdfast only with regeneration evident. Also, the number of receptacles on each reproductive plant was recorded once during the first summer and on all sampling dates during subsequent field seasons. Percent cover of all organisms was estimated by placing a 50-point grid over the quadrat. All drift algae were removed before assessment of percent cover. The study plots were monitored every two weeks during a three-month period in the first summer, 1990. In the second season, 1991, the quadrats were visited on three occasions, once each in April, June, and August and, during the third year, 1992, once each in May and August.

***Fucus* Reproductive Potential and Egg Viability**

In 1991, the relative fertility of *Fucus* at oiled and control sites was assessed by measuring the rate of egg release from randomly selected receptacles on plants. In addition, the viability of the released eggs was determined. Plants for this study were collected from the same sites as those used for the population dynamics study (see above). The nearest plants with undamaged receptacles to the origin of 0.5 m radius semicircular areas on either side of each quadrat were collected. Plants were collected three times during the summer and within two days of population dynamics monitoring. Plants at paired oiled and control sites were collected on the same day. For each plant collected, one randomly chosen receptacle was cut from the plant, rinsed in freshwater for about 10 seconds, blotted dry, and placed between two paper towels in the dark at 8-10°C for 24 hours. The receptacles were then weighed and placed in resealable plastic vials with 20 ml of sterile seawater and placed in an incubator at 8-10°C with a photoperiod of 16:8 (L:D) at 50-80 micromoles/m²/s light. During the 48 hour incubation period the samples were shaken every 8 hours to prevent released eggs from attaching to the walls of the vials. After the incubation period the receptacles were removed from the vials and 2.0 ml of 0.1% Calcoflour stain was added and allowed to be absorbed by any living cells for 30 minutes. Then 7.0 ml of 20% formalin was added to each bottle.

The total number of eggs released by each receptacle was determined by estimating the number of eggs in each vial. Each sample was thoroughly mixed and transferred to a 9 cm petri dish. The number of eggs in 10 randomly chosen fields of view of a dissecting microscope (25X) were counted. These ten counts were then extrapolated to obtain an estimate of the total number of eggs in each vial.

The viability of the eggs produced by each receptacle was also evaluated. After the number of eggs was determined, the egg solutions were transferred to

centrifuge tubes and centrifuged for less than 10 seconds or allowed to settle for at least 16 hours. Four drops of concentrated samples were transferred to a microscope slide and examined under a fluorescent microscope. The number of unfertilized (non-fluorescent) eggs and fertilized eggs (fluorescent) were counted until 100 eggs were examined. If less than 100 eggs were examined, then up to 5 additional slides were prepared until 100 eggs had been examined. If after examination of six slides there were still less than 100 eggs examined, the number counted for all slides was recorded.

Fertility of Floating *Fucus*

To assess the possibility of recolonization of denuded shorelines by drift *Fucus* plants, the reproductive potential of drift plants was determined. To obtain drift plants, a skiff was driven at about 1.5-2.0 m/s, and any plants within 1 m of the bow of the skiff were collected. Collections were made along three transects on each sampling date. Each transect originated from an oiled site in the southwest finger of Herring Bay. The sites were 2333X, 3611X, and 1852X. Starting as close as was safe to the shoreline, the skiff was driven in a random compass direction until the shore was encountered at which time the skiff was driven in a new random compass direction. Each transect was run until 10 plants had been collected. The three sampling dates were 22 May, 3 June, and 8 August 1991.

After collection, the plants were treated exactly the same as the plants collected in the *Fucus* reproductive potential and egg viability study above.

***Fucus* Germling Growth and Survival**

In 1991, petri dishes (9x60 mm) were seeded with approximately equal densities (144 eggs/cm²) of *Fucus* eggs in the lab at Juneau and incubated for about one month (Table 2.1). The seeded plates were then shipped in a cooled container to Herring Bay. The seeded plates were paired with unseeded plates and bolted to rock surfaces at 1 and 2 MVD at three pairs of matched oiled and control sites. Four pairs of plates were placed at each level at each site. The locations of the four transect origins were determined using the same procedure as for the population dynamics study. The percent cover of *Fucus* was estimated on each plate in the field about once every ten days. Two complete sets of plates were deployed over the summer. The first set was placed in the field in May and the second in June (Table 2.1).

To investigate differences in desiccation rates among sites and how these differences may affect germling survival, drying rates were measured at the first MVD plate locations and these were correlated to the estimated percent cover of *Fucus* on the plates. Desiccation rate was measured by placing freezer container lids with wetted cotton balls on them in the field and measuring the weight loss over time. One lid and cotton ball combination was placed near each set of 1 MVD

plates at all sites as the tide receded and exposed the plates. The lids and cotton balls were collected just before they were again covered by the rising tide. Due to time constraints and limited periods of hot, sunny weather, these observations were carried out only once, in June 1991 after the second set of plates was placed in the field.

The effect of whiplash motions of adult *Fucus* on survival of germlings was also investigated experimentally. Plates with germlings on them were mounted on a plywood board and suspended just under the water surface in an area subjected to wave action. One end of the board was weighted to keep the board vertical. Herbivores were excluded from the board since it was suspended in open water by ropes attached above the tideline. Adult *Fucus* plants were suspended above four of the plates by sandwiching the stipes of the adult plants between the plywood and another board bolted to the plywood. Three other plates served as controls with no adult *Fucus* plants.

Due to rapid, high mortality of germlings on the petri dishes, a second set of similar experiments was initiated in 1992. This set of experiments used handmade ceramic tiles (6x8 cm) with grooves of three widths (0.80 mm, 0.50 mm, and 0.15 mm) and two depths (1.50 mm, 0.30 mm) scored into them before firing. The tiles were made with Pine Lake Red Stoneware clay and fired at cone 10 with no glazes or colorants. The six different sizes of grooves (3 widths x 2 depths) were randomly ordered horizontally on each tile (Fig. 2.1). The tiles were attached to the substratum with a screw through a central hole in the tile. Three grooves were above the mounting hole and three below it.

The effects of a number of factors on germling survival were investigated using these tiles. To evaluate the effects of adult *Fucus* canopy, tidal level, oiling history at the site, and prior seeding, eight plates were deployed at each of three control and three oiled sites. Four plates were placed at the 0.5 MVD and four at 1.0 MVD. At each level, pairs of plates were separated by one meter. One randomly chosen group was designated a *Fucus* canopy treatment and the other had no *Fucus* canopy. If a *Fucus* canopy was present in the no *Fucus* canopy treatment, the plants able to cover the tiles were removed. If there was no *Fucus* canopy in the *Fucus* canopy treatment, then *Fucus* plants taken from the same tidal height were transplanted just above the tiles by chipping off the rock with the plant attached and using Z-Spar marine epoxy putty to secure the rock and plant in place. Each tile pair consisted of one seeded and one unseeded tile. The seeded tile was inoculated with *Fucus* eggs gathered from plants in Juneau. After inoculation the tiles were incubated in sterile seawater for about one month before shipping to Herring Bay and deployment in early July (Table 2.1). At the time of deployment, all germlings were about 0.5mm in length. The location of the upper left tile of each quartet was determined by measuring the length of the site, subtracting 1 meter and multiplying by a random number.

In addition to the factors mentioned thus far, the effect of herbivores on germling survival was investigated using additional plates deployed at the same time. Herbivores were excluded by encasing tiles in Vexar mesh (about 3.5mm mesh size) and securing the tile and cage to the substratum with a screw (Fig. 2.1). To control for cage effects, tiles were also placed in a cage open at the bottom, allowing herbivores access. Uncaged control tiles were also used. All tiles were seeded and all *Fucus* canopy was removed from around the tiles. At each of the six sites, two sets of the three treatments were deployed, one at 1.0 MVD the other at 2.0 MVD. The 1 MVD set used the no *Fucus*-canopy, seeded tile from the preceding experimental design as the control tile. The two caging treatments were placed next to the control tile. The 2 MVD treatments were placed directly below the 1 MVD caging treatments.

For all tiles, the number of germlings in each groove was counted immediately before placement in the field, and an area between the first and second grooves equal to the width of the widest groove was also counted to assess survival outside of grooves. After two months in the field, the tiles were retrieved and the same counts were taken. After counting, the tiles were returned to the field.

Growth of Established *Fucus* Plants

To determine growth rates of *Fucus* plants in Herring Bay and estimate recovery time for these plants, individual plants were tagged and monitored for subsequent growth. Six randomly chosen plants in each of 3 size categories at each of three tidal levels were tagged by gluing a small uniquely labeled tag next to the plant with marine epoxy. The plants were chosen by finding the nearest plant in the specified tidal level to a randomly selected point on the shore. The randomly selected points were located using the same procedure to locate the quadrats in the population dynamics study except that the quadrat length and width were not subtracted from the segment or transect lengths. The distance from each point to the chosen plant was recorded for each selected plant, giving an estimate of plant density of the various size categories at each site. Eighteen plants in each size category were marked at each of two pairs of control and oiled sites. The size categories consisted of small plants (2-4.5 cm length, medium plants (5-10 cm), and large, reproductive plants (>10cm). All plants were marked and measured between 16-19 May 1991. If plants were reproductive, the number of receptacles was counted for each plant. Plants were remeasured on 22-23 August 1991 and 27-28 July 1992.

If tags or plants were lost or the plants grew into a new size class, then new plants were located and tagged by selecting the nearest plant to the original, randomly located point. After each sampling period, the number of plants in each size class at each tidal height was restored to at least six by this retagging procedure. Sample sizes can be greater than six if plants from a smaller size class grew into the next larger size class and there was no mortality in the larger size

class. Since growth is the variable of interest here only positive or zero growth values were used in the analyses, eliminating any negative growth resulting from damage to the plant.

Fucus Egg Density

The number of *Fucus* eggs settling on oiled and control beaches was estimated by deploying acrylic plates designed to catch *Fucus* eggs (Fig. 2.2). The plates were 5x10 cm and had nine grooves etched in them. The width of the grooves (125 μm) was slightly larger than the width of an average *Fucus* egg (75 μm). Eggs falling on the plates would be likely to be trapped in the grooves. The plates were set out for one day at a time for three (1992) or four (1991) days in a row. A plate was placed at each of three tidal levels (0.5, 1.0, 2.0 MVDs) along four transects, for a total of 12 plates per beach. One transect was placed at either end of the site and the remaining two transects were equally spaced between them. This experiment was performed at four pairs of oiled and control sites in May, June, and August in 1991 and 1992. Two of the sites used in 1991 were also used in 1992, but two new sites replaced two old sites in 1992. In August 1991 and on all sampling dates in 1992, the distance and direction to the nearest fertile *Fucus* plant for each plate was recorded.

Statistical Methods

The same basic statistical procedure was followed for most observations. For any given type of data, comparisons were ultimately made for each pair of sites only, but, where appropriate, the pooled estimate of variance for all sites of a given habitat type was used. Raw data for all pairs of sites were checked for homogeneity of variances using Levene's test at the $p=0.10$ level. If variances were unequal, then the data were transformed using either an arcsin (percent cover data) or log transformation (all other data), and Levene's test was again applied on the transformed data. If either the raw or transformed variances were equal, then a one-way ANOVA was performed on all sites and contrasts between oiled and control sites within a pair were used to detect differences between oiled and control sites. If neither the raw nor the transformed variances were equal, then a regular t-test was used to compare each pair of sites. Before applying the t-test, however, raw data variances for each pair of sites were tested for homogeneity using the F-max test. If variances were not equal, then the raw data was transformed using either of the two transformations mentioned above and the F-max test was again applied. If the transformation failed to alleviate the heteroscedasticity, then a regular t-test with Satterthwaite's correction for non-homogeneous variances was applied to the raw data. In some cases, simple t-tests were performed without attempting to use a pooled estimate of variance. When these simple t-tests were employed the procedure above was applied as if neither the raw nor transformed data had homogeneous variances for all sites. In a small number of cases involving multifactorial experiments, two- or three-way ANOVAs were used on the raw data if variances were judged to be homogeneous

according to a F-max test. In cases where variances were not homogeneous, log transformations were used. The transformations did not always cure the heteroscedasticity, and in cases where variances remained non-homogeneous the ANOVA was carried out on the raw or transformed data, whichever had the more homogeneous variances. In cases where this was done, the fact that the assumptions of ANOVA were violated is indicated in the presentation of the data. All figures and tables represent raw means and one standard error of the mean. Statistical significance is indicated by one star ($p < 0.05$), two stars ($p < 0.01$), or three stars ($p < 0.001$).

ALGAL RESULTS

Population Dynamics-Sheltered Rocky Sites

At site pair 1231C/1231X, a gently sloping sheltered rocky pair, there were fewer large plants (>10 cm) at the oiled site in the first and second MVDs during the first two years of sampling (Fig. 2.3). In the first MVD only one difference was statistically significant, due to low densities and high variability. On all dates in the first two years at the second MVD, all differences in large plant abundance were statistically significant. On the last sampling date in 1992 in the third MVD there were more large plants at the oiled site. Medium sized (5.5-10.0cm) plants also showed lower abundances initially at the oiled sites during the first year in the first and second MVDs, but only two of these differences were statistically significant. There were more medium sized plants at the oiled site at the end of the second summer (3 MVD) and in the third year (2 MVD), although only three of the differences were significant (Fig. 2.3). On most dates, small plant density, 2.5-5 cm, was less in the first MVD at the oiled site in 1990, but there were no differences in subsequent years (Fig. 2.4). In the second MVD, however, there were more small plants at the oiled site in all years with significant differences in the second and third years. The oiled site had significantly more germlings (0-2 cm plants) in the second MVD during the first year and early in the second year of sampling (Fig. 2.4). There were no other significant differences for this size class.

A more steeply sloped sheltered rocky pair, 1732C/1732X, had few significant differences in plant densities of plants in any size category (Figs. 2.5, 2.6). In the third year of sampling, there were more germlings in the second and third MVDs at the control site (Fig. 2.6).

At the vertical wall sites, 3811C/3611X, there were significantly more large plants (>10 cm height) at the control site in the first MVD during the first two years of sampling (Fig. 2.7). Differences were no longer significant in 1992 due to an increase in plant density at the oiled site. In the second MVD there were more large plants in the third year only at the oiled site. There were no differences in the number of large plants for any year in the third MVD. Medium sized plants (5.5-10 cm) showed significantly lower abundances in the second and third MVDs

at the oiled site on a few dates in 1990 (Fig. 2.7). By 1992, plant numbers were increasing at the oiled site for all three MVDs. Small plants (2.5-5 cm) were also significantly less abundant at the oiled site in the first and third MVDs on half of the sampling dates in 1990 (Fig. 2.8). There were no other significant differences in the abundance of small plants except in the third MVD in 1992. The trend, however, was toward higher abundances at the oiled site in 1991 and 1992. Germlings (0-2 cm) were significantly less abundant in the third MVD at the oiled site during all three years, but there were more germlings in the second MVD at the oiled site at the end of the first summer (Fig. 2.8). In the third MVD, germlings tended to be significantly more abundant at the control site until the end of 1992.

At sites 1231C/1231X, there were more reproductive plants at the control site in the first and second MVD, but due to low numbers and high variability, the differences were significant on most sampling dates only in 2 MVD (Fig. 2.9). There were no differences in the third MVD. A similar pattern occurred for receptacles per quadrat, with significant differences on all dates in 2 MVD and spring of 1992 in 1 MVD. For site pair 1732C/1732X, there was only one significant difference in the number of reproductive plants in the third MVD in 1991 in which there were more plants at the control site (Fig. 2.10). There were no significant differences in the number of receptacles per quadrat, although there were consistently more receptacles at the control site in the first MVD until the end of 1992 (Fig. 2.10). For 1991 and early 1992 at site pair 3811C/3611X, there were significantly more reproductive plants and receptacles per quadrat on control sites in the first MVD (Fig. 2.11). The only other significant difference was the number of reproductive plants was greater at the control site in the second MVD in 1990.

The percent cover of *Fucus* and other algae was also different between control and oiled sites in some cases. At the 1231C/1231X site pair, *Fucus* cover was lower, but not significantly so, at the oiled site in the first MVD for all three years (Fig. 2.12). *Fucus* cover was significantly lower at the oiled site in the second MVD through June 1991. Although there was not any convergence of *Fucus* cover in the first MVD as of 1992, cover tripled from 1990 to 1992 in the second and third MVDs at the oiled site. Weedy, ephemeral species had higher cover at the oiled site in the second and third MVDs through the middle of 1991 but differences were only significant in the third MVD (Fig. 2.12). Likewise, the 1732C/1732X site pair showed higher cover of ephemeral algae at the oiled site in the second and third MVDs on some dates in 1990 (Fig. 2.13). At this site, however, there were no differences in the cover of *Fucus*. Once in 1991, however, the cover of ephemeral algae was greater at the control site. Similar patterns can be seen in the percent cover data for the 3811C/3611X site pair (Fig. 2.14). *Fucus* cover was significantly lower at the oiled site at all levels with significant differences in the first and third MVDs. In the third MVD differences were only detectable through August 1990, but, in the first MVD, the differences extended into 1991. Percent cover of *Fucus* tended to increase at the oiled site in the second

and third MVDs in 1991 and 1992. Ephemeral species had significantly higher percent covers at all tidal levels at the oiled site in 1990 and early 1991 (Fig. 2.14). The percent cover of ephemerals at oiled sites tended to decline over time, especially in the first MVD, converging to control values.

Population Dynamics-Coarse Textured Sites

Algae were sparse in the first two MVDs at the two coarse-textured site pairs, so only third MVD results are reported. The size distribution of *Fucus* plants at the coarse textured sites (Fig. 2.15, 2.16) showed patterns somewhat similar to those given above for sheltered rocky sites. Germlings (0-2 cm) tended to be more abundant at the oiled sites with significant differences occurring on three sampling dates at site pair 2333C/2333X (Fig. 2.15). At the other site pair, 2834C/2834X, there were no differences in the number of germlings (Fig. 2.16). At both site pairs there was no difference in the abundance of small plants (2.5-5.0 cm) in 1990 but, in 1991 and 1992, they became more abundant at oiled sites (Fig. 2.15, 2.16). There were significant differences at site pair 2333C/2333X on all 1991 and 1992 dates, but there was only one difference at the 2834C/2834X site pair in 1991. The medium sized plants (5.5-10 cm) at both site pairs tended to become more abundant at the oiled sites in 1991 and significantly so in 1992. Larger plants (>10 cm) tended to be more abundant at control sites in 1990 and 1991, but this difference was only significant on the first sampling date at the 2333C/2333X site pair. In 1992, large plants became significantly more abundant at oiled sites at both site pairs. There were no significant differences in the number of reproductive plants or the number of receptacles per quadrat at either coarse textured site pair (Fig. 2.17). The number of reproductive plants and receptacles was much lower compared to sheltered rocky site. In the first two years, there were always more reproductive plants and receptacles per quadrat at the control sites, but due to high variation and low numbers, none of these differences were statistically significant.

In the third MVD, the percent cover of *Fucus* was significantly lower at the oiled sites in 1990 on a few sampling dates at both coarse textured site pairs (Fig. 2.18). In 1992 at the 2333C/2333X site pair, *Fucus* cover was significantly higher at the oiled site. There were no differences in the percent cover of ephemeral algae at either site pair (Fig. 2.18).

Both coarse textured site pairs showed similar temporal patterns (Figs. 2.15, 2.16). In 1990 at the oiled sites, there were fewer large plants and more germlings at each site pair. In 1991, the abundance of small plants had increased at both oiled sites, and in 1992 there were increases in the number of medium and large plants at both oiled sites. Thus, at both oiled sites, a cohort of plants can be seen to recruit in 1990 and grow to larger size classes in subsequent years. This recolonization can also be seen in the gradual increase of the percent cover of *Fucus* at both oiled sites (Fig. 2.18).

Population Dynamics-Reproductive Plant Quality

Examination of reproductive plants at all sites, both sheltered rocky and coarse textured, revealed that at oiled sites reproductive plants were shorter than those at control sites in the second and third MVDs early in 1990, in the first and second MVDs at times in 1991, and in all MVDs in 1992 (Fig. 2.19). Also, *Fucus* at control sites had more receptacles per plant in the first and second MVD in spring of 1992 (Fig. 2.19). There were no significant differences at other times on in the third MVD. These data include all reproductive plants observed at all sites.

Reproductive Potential and Egg Viability

At all times and at all levels, the average number of reproductive plants, out of 12 possible, collected at the three pairs of sheltered rocky sites was greater at control sites than at oiled sites (Table 2.2). However, differences were only significant in the first MVD during the second and third sampling periods and in the third MVD during the third sampling period. This result indicates that there were fewer reproductive plants at oiled sites and is consistent with the reproductive plant densities observed in the population dynamics study (Fig. 2.9, 2.10, 2.11).

The wet weight of the collected receptacles was significantly greater at control sites relative to oiled sites in the third MVD during the second sampling period and in the second MVD during the third sampling period (Table 2.2). In addition, similar, but not significant, reductions in receptacle weight at oiled sites can be seen in the second MVD during the second sampling period and in the third MVD during the third sampling period.

There were two significant differences in the total number of eggs produced by receptacles from oiled and control areas (Table 2.2). In the second MVD during the first sampling period, more eggs were produced by the oiled receptacles. In the first MVD during the second sampling period, more eggs were produced by receptacles from control sites.

The proportion of eggs which were viable was significantly greater at oiled sites during the first sampling period in the second and third MVDs (Table 2.2). However, during the second sampling period in the second MVD the proportion of viable eggs was greater at the control sites. The direction of these differences is the same as for the number of eggs produced. Combining these two data sets, suggests that the number of viable eggs released by oiled receptacles is greater early in the season in the second and third MVDs, but later in the season receptacles from control beaches release more viable eggs. Late in the season, all released eggs were viable and there were no differences in the egg release rate.

Fertility of Floating *Fucus*

No significant differences were detected in the egg release rates between drift and attached plants (Table 2.2). However, the proportion of viable eggs was greater for attached plants in the second and third sampling periods. During the last sampling period, all eggs produced by attached plants were fertile compared to 38.1% for drift plants. Since there was no variance for the attached plants, no statistical test was performed. At all times, the wet weight of receptacles from drift plants was greater than for attached plants. Drift receptacles were about twice as heavy as attached receptacles.

Germling Growth and Survival

In 1991, there were dramatic decreases in the estimated percent cover of germlings in the petri dishes immediately after placing them in the field, probably due to physical conditions in the upper intertidal area. Measurements of field desiccation rates indicated that oiled sites had higher drying rates than control beaches (Table 2.3). The estimated percent cover of germlings was negatively correlated with drying rate (Fig. 2.20). Where desiccation was greater, fewer germlings survived.

A *Fucus* canopy can also lower survival of germlings. Young germlings may be knocked off the substrate by the fronds of large plants being moved about by wave action. Germlings growing on plates subjected to whiplash from large plants showed much higher mortality than germlings without large plants present (Table 2.4). On rock surfaces, germlings probably have a refuge from whiplash in small cracks and crevices.

The effect of groove size on germling recruitment and survival, was statistically analyzed by treating each tile as a block and the different size grooves were compared using a one-way ANOVA. These tests were performed on either raw or log transformed data whichever had homogeneous variances indicated by a F-max test. Contrasts were used to make comparisons of different types of grooves. For each variable, five contrasts were tested: 1) grooves versus no grooves, 2) deep grooves versus shallow grooves, 3) narrow versus medium width grooves, 4) narrow versus wide grooves, and 5) medium versus wide grooves. This procedure was done, rather than making all possible comparisons, because it is both more powerful and allows specific hypotheses to be tested.

The initial seeding densities on the grooved tiles varied between groove widths but not depths (Fig. 2.21). There were more germlings in wider grooves than in narrower grooves. This was probably due to the increased surface area of wider grooves compared to narrower grooves. There were also more germlings in grooves than out of grooves. This can be attributed to the tendency for eggs to gather in grooves. Any slight movement of the tile immediately after seeding, before the eggs have attached to the substrate, would cause some of the eggs to

fall into the grooves. To account for the differences in initial seeding densities, the percent survival of germlings was calculated by dividing the number of germlings observed after two months in the field by the initial number of germlings. Due to natural recruitment of germlings, it was possible for this value to be greater than 1. A higher proportion of germlings survived in grooves than out of grooves (Fig. 2.22). Survival rate was higher in medium and narrow grooves than in wide grooves, but there was no difference between deep and shallow grooves. Natural recruitment was monitored on the unseeded tiles (Fig. 2.23). Germlings never recruited naturally onto the tiles outside of the grooves. Natural recruits were more abundant in medium grooves compared to narrow grooves. No other differences of groove size were detected for the natural recruitment of germlings.

To examine the effects of *Fucus* canopy, tidal height, and oiling on germling survival, the number of germlings in all sampling areas on each tile were summed yielding a total number of germlings counted per plate. Thus, the dependent variable here is the number of germlings per plate regardless of groove size. A three-way ANOVA on the percent survival of germlings yielded three significant effects. First, there was an effect of site pair, indicating that there were differences in germling survival between site pairs (Fig. 2.24). Second, germling survival was higher in control areas compared to oiled areas indicated by the significant oil effect. Finally, germling survival was greater under *Fucus* canopy compared to no canopy treatments. Natural recruitment of germlings showed similar patterns to germling survival (Fig. 2.24). First, there was a significant site pair effect, indicating differences in recruitment between site pairs. There was also an effect of oiling. Natural recruitment was higher at control sites compared to oiled sites. Finally, there was a trend, but not a significant one ($p=0.123$), that recruitment was greater under *Fucus* canopy. This seems to be especially true at oiled sites which tended to lack natural *Fucus* canopy.

The effect of herbivores on germling percent survival and recruitment was examined in a similar manner by evaluating the number of germlings over entire plates and ignoring groove size (Table 2.5). There were no detectable effects of cage treatment, tidal height, or oiling on the survival of germlings in a three-way ANOVA.

Growth of Established *Fucus* Plants

In 1991 when this experiment was set up, the distance to the nearest plant of the two larger size classes was greater at oiled beaches than control beaches in the first MVD, indicating a lower density of plants at the oiled sites (Fig. 2.25). At sites 1221C/1221X, the largest size class also had lower densities in the second and third MVDs at the oiled site. The smallest plants (2-5 cm) in the first MVD showed a trend towards greater distances at oiled sites.

Because sample sizes were small due to loss of plants, tagged plants from both site pairs were grouped together, yielding a larger number of control and

oiled plants for comparison using simple t-tests. This, however, reduces the generality of the results. During the summer of 1991, small plants in the first MVD grew faster at oiled sites than at control sites (Fig. 2.26). The yearly growth rates, from late summer 1991 to summer 1992, showed that plants of all size classes grew faster at oiled sites in the first MVD (Fig. 2.26). In addition, large plants in the second MVD grew faster at oiled sites.

Fucus Egg Density

The egg capture rate with grooved plates was higher on the control beaches than on the oiled beaches at the 0.5 and 1.0 MVD in all cases during the second and third sampling periods in 1991 (Fig. 2.27) and in one of the four matched pairs during the first sampling period in 1991. At the 2.0 MVD in 1991 there were no differences in capture rate during the first time period. However, during both the second and third time periods there were significantly more eggs at the control beaches in all but one case. In 1992 during all sampling periods, more eggs were captured at control sites at the 0.5 and 1.0 MVD in all but two cases (Fig. 2.28). One of the four pairs had lower capture rates at the oiled site at the 2.0 MVD during each of the first two time periods in 1992. During the final sampling period in 1992 at the 2.0 MVD, three of the four pairs showed lower egg densities at the oiled sites.

In 1992, the distance from each plate to the nearest fertile *Fucus* plant was measured, giving an index of density of reproductive plants (Fig. 2.29). At the 0.5 MVD, the distance to the nearest reproductive plant was greater at the oiled site of all pairs during all time periods except one. At the 1.0 MVD three of the pairs had longer distances to the nearest fertile plant at the oiled sites during the first and third time periods. During the second time period only one pair showed a significant difference at the 1 MVD. There were no significant differences at the 2.0 MVD.

DISCUSSION OF ALGAL STUDIES

The information gathered on *Fucus* size indicates that many larger plants were killed or removed by the oil spill and subsequent clean-up efforts. This result occurred only in the first two meters of vertical drop at sheltered rocky sites, showing that the effects of the spill were concentrated in the upper portion of the intertidal zone in this habitat, but ephemeral algae was also more abundant in the third MVD. At coarse-textured sites, the same result can be seen in the third MVD where algae are found. In addition, the number of reproductive plants and receptacles per quadrat had lower densities in the first two MVDs at oiled sites. The quality (length of plant and number of receptacles per plant) of reproductive plants at oiled sites differed from control sites. At oiled sites, reproductive plants were shorter and had fewer receptacles than at control sites. This result could be due to a larger proportion of relatively young reproductive plants at oiled sites. If this were the case, then the length and number of

receptacles would be expected to increase over time at the oiled sites as plants grow and produce more receptacles. No convergence of length and number of receptacles per plant can be seen in the data as would be expected if young reproductive plants at oiled sites were growing larger. The difference in quality of reproductive plants has not changed over the three year sampling period, suggesting that reproductive plants at oiled sites were damaged.

Lower percent coverage of *Fucus* at oiled sites was a result of the removal of large, reproductive plants. *Fucus* cover was lower at the same oiled sites and tidal levels where the density of large plants was reduced. The loss of the dominant alga also led to increases in the cover of weedy, ephemeral algal species such as *Cladophora*, *Scytosiphon*, and *Enteromorpha*. In many habitats, ephemeral species are indicative of recently disturbed areas where the competitive dominant has been removed (Lubchenco 1978; Sousa 1979).

The CHIA studies (Highsmith et al. 1993) found similar results to those described above at least in Prince William Sound. They documented lower densities of reproductive *Fucus* plants as well as larger plants (12-17.5cm) on oiled sites. There were also fewer receptacles per plant and quadrat at oiled sites. Biomass and percent cover of *Fucus* and ephemeral algae also showed similar patterns to those described in this report. The percent cover and biomass of *Fucus* was lower at oiled sites, and the cover and biomass of ephemeral algae was greater at oiled sites. These results occurred primarily in the first MVD in Prince William Sound. Thus large, mature *Fucus* plants were less abundant at oiled sites in the entire Prince William Sound area, resulting in lower percent cover and biomass of *Fucus*. Highsmith et al. (1993) also observed more attached ephemeral algae and epiphytes on *Fucus* at oiled sites. Since epiphytes were classed with ephemeral algae in this study, the greater abundance of ephemeral algae at oiled sites observed in this study applies over the entire region.

However, the general results described above were not uniform at all sites. Only two, the gently sloping pair 1231C/1231X and the vertical wall pair 3811C/3611X, of the sheltered rocky site pairs sampled showed these patterns. The remaining site pair, the intermediately sloped pair 1732C/1732X, showed little or no effect of the oil spill. The variability between sites may be due in part to different clean-up treatments applied to the sites. Site 1732X was not treated to remove oil but sites 1231X and 3611X were treated (Table 1.1). Though the evidence is circumstantial, it is likely that clean-up efforts caused much of the decrease in *Fucus* canopy. First, observations of adult *Fucus* plants at heavily oiled sites suggest that *Fucus* may be able to withstand a fairly high degree of oiling. Adult *Fucus* plants in other areas have also been observed to be tolerant of oiling due to non-adherence of oil to the thallus and blades of the plants (Crothers 1983), making the plants resistant to the physical smothering of the plants by the oil. Secondly, where the *Fucus* canopy was removed, the rock was mostly clear of oil except for small amounts in cracks and crevices in the rock, and there were often holdfasts still attached to the rock indicating that *Fucus* was once abundant

(De Vogelaere and Foster 1993). There were also very few organisms present at these sites. These observations suggest that these sites were mechanically cleaned of oil in some manner. Finally, photographs of cleaning equipment in action have shown large amounts of floating *Fucus* within the containment boom during and after cleaning. These plants probably came from the rock being cleaned since the density of floating *Fucus* was visually much lower in surrounding areas.

In order for *Fucus* to recover from the damages documented in the Herring Bay studies, plants must settle as eggs and develop into germlings, survive to adulthood and, because of the short dispersal distance of *Fucus* eggs, become reproductive to continue local recolonization of impacted areas. As a result of the reduction of reproductive *Fucus* plants in oiled areas, fewer eggs were found to settle on oiled shorelines. The number of eggs settling on oiled beaches was much lower than on control sites at all tidal levels examined even two and three years after the spill. Differences were greater higher in the intertidal and were observed at six pairs of sites over two years. The density of reproductive plants at these sites was lower as shown by longer distances to the nearest fertile plants in 1992. Because eggs rarely travel more than one meter from the parental plant and are much more abundant near the source plant (McConnaughey 1985), the lower settlement rates observed can be attributed to lower densities of reproductive plants.

After recruiting on rock surfaces, germlings face a variety of challenges before reaching adulthood. In normal situations with a healthy canopy of *Fucus*, germlings are subjected to grazing pressures from molluscan herbivores such as limpets and snails. Although this study did not demonstrate any significant effect of herbivory on germling survival, there still may be significant grazing pressure on slightly older germlings. At very young stages (<1mm in length), germling recruitment may be driven more by whiplash, desiccation, heating, and settlement. As plants grow to greater than 1 mm, herbivores may become more important to germling survival due to higher plant attractiveness to herbivores due to increased energy per plant (Gaines and Lubchenco 1981). If this is true, then effects of herbivores will not be seen immediately but may be detected later in experiments. Germling survival will be monitored in the herbivore experiment in spring 1993, allowing more definite conclusions about the role of herbivores on *Fucus* recruitment. Germlings may also be brushed off the rock surface by adult plants thrust back and forth by wave action (Table 2.4). Cracks and crevices in the rock surfaces may provide a refuge from both herbivory and whiplash (Lubchenco 1984, Fig. 2.22). Conversely, at oiled sites lacking a healthy canopy of adult *Fucus* and associated herbivores, germlings are not subjected to strong herbivory or the whiplash effect of adult plants, but they are subjected to increased heat and desiccation stress (Table 2.3). In the *Fucus* canopy, desiccation is relatively low while outside of *Fucus* beds on exposed rock surfaces desiccation can be severe, especially in the high intertidal (Brawley and Johnson 1991). Experimentally, germling survival was found to be higher where desiccation stress was lower (Fig. 2.20) and under the *Fucus* canopy (Fig. 2.24). Germling survival was also lower at

oiled sites, lacking *Fucus* canopy and subjected to severe heat and desiccation stress. Temperatures exceeding 43°C have been recorded for tiles placed in the high intertidal zone at oiled sites in Herring Bay. Although it appears that cracks and crevices can provide some protection from heat and desiccation stress, cracks alone are not sufficient to allow survival of young *Fucus* germlings. Germling survival is lower without *Fucus* canopy regardless of the presence of cracks. However, cracks do seem to provide protection from whiplash by adult plants and herbivory by allowing newly recruited germlings to grow to sizes (>0.5cm) more resistant to these mortality sources before being exposed to them (Lubchenco 1984). Although germlings recruiting under *Fucus* canopy may face survival challenges in the form of herbivory and whiplash, the alternative of recruiting in areas without *Fucus* canopy seems to present more severe threats to future survival by heating and desiccation stresses.

Growth rates of established *Fucus* plants during the 1991-1992 year were greater at oiled sites in the upper intertidal for all size classes of plants. This is probably a result of lower densities of *Fucus* plants, especially larger plants, at oiled sites resulting in reduced intraspecific competition for light, nutrients, or space (Kendziorek and Stekoll 1984). Once germlings become established at damaged sites, recovery can proceed rapidly due to growth rates of about 7 cm per year. Plants at control sites only grew at a rate of about 3 cm per year.

Recovery of *Fucus* is evident at some oiled sites. For example, at the 1231C/1231X site pair in the second MVD there were more germlings (0-2.0 cm) in 1990 at the oiled site. Later in 1990 and early in 1991 there were more small plants (2.5-5.0 cm), in 1991 there were more medium plants (5.5-10 cm), and in 1992 there was an increase of large plants at the site. Thus, over time the plants grew into successively larger size classes. Similar patterns were found at the vertical wall sites, 3811C/3611X, and the course textured site pair, 2333C/2333X. Recovery has begun in the upper intertidal at sheltered rocky sites but is proceeding more slowly than in lower zones. The number of 5-10 cm and >10 cm plants has increased in 1991 (5-10 cm) and 1992 (>10 cm) at oiled sites in the first MVD to levels similar to control sites (Fig. 2.3, 2.5, 2.7). These increases occurred earlier in lower tidal levels. A similar pattern of recovery was seen in Bristol Bay when larger numbers of small plants were observed in plots cleared of *Fucus* (Kendziorek and Stekoll 1984). Predictably, as the number of plants at oiled sites increased, the percent cover of *Fucus* also increased, especially as the plants grew to larger sizes.

Recolonization will be greatly inhibited by exposure to the terrestrial environment in the upper intertidal where *Fucus* canopy has been removed by the oil spill or clean-up activities. One method by which recovery may proceed in areas which have lost all *Fucus* plants in the high intertidal is expansion of *Fucus* beds from low in the intertidal and recruitment into cracks and crevices. As *Fucus* plants lower in the intertidal or in cracks grow to reproductive status, taking about 2-3 years at linear growth rates of 7.0 cm per year, they will provide

both a source of eggs and protection from harsh terrestrial conditions for germlings. Desiccation will be reduced in areas immediately surrounding the *Fucus* canopy where adult plants cover the rock surface during low tides. The boundaries of *Fucus* beds can slowly expand as plants on the edges grow, become reproductive, release eggs, and provide shelter for newly settled germlings. The rate of expansion can be estimated by considering that eggs do not usually travel more than 0.5 meter from the source plant and that it takes about 3-4 years for a plant to fully mature. Thus the expansion rate would be about 0.5m every 3-4 years.



Figure 2.1. Schematic diagram of a coastal *Fucus* experiment. The and the
 1/2 liter cages used to manipulate fertilizers. To control for cage effects the cages
 were left off at one end of the same cage when that end of the cage
 was open to fertilizers.

FUCUS RECRUITMENT TILES

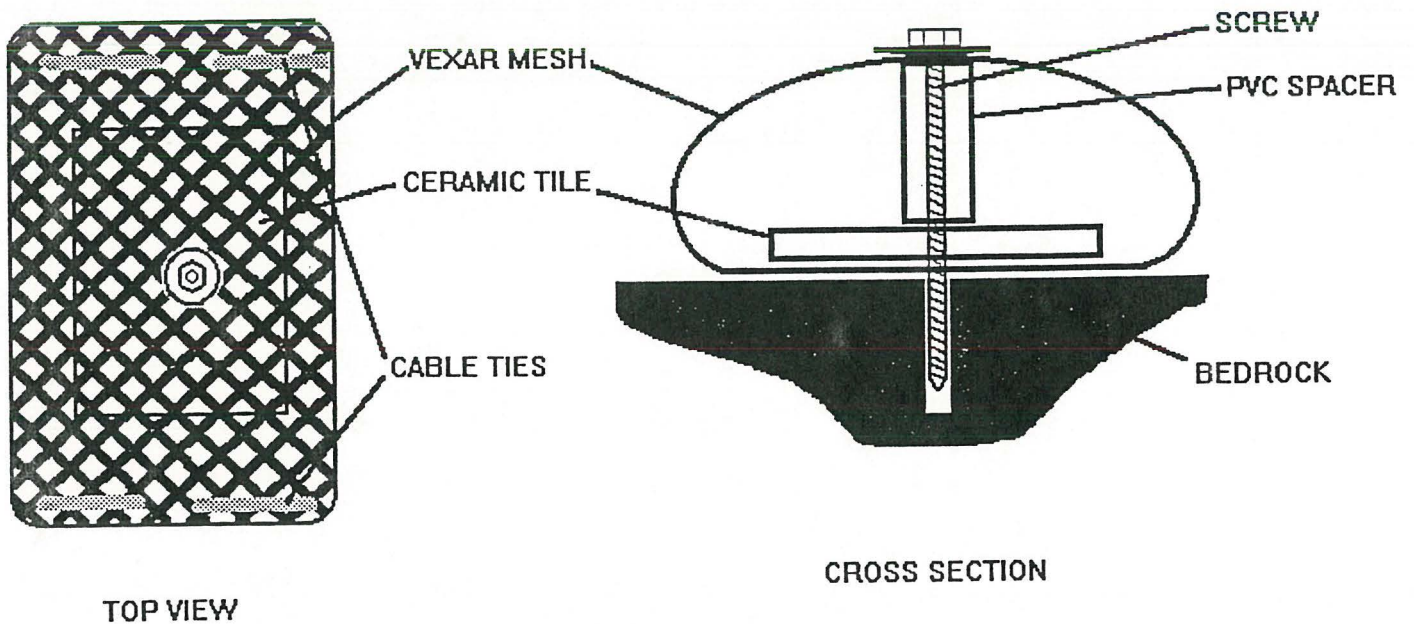
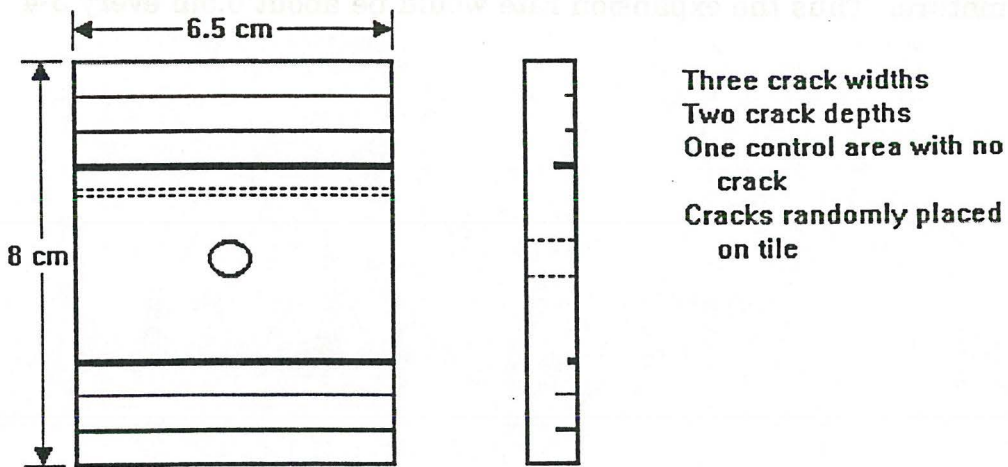
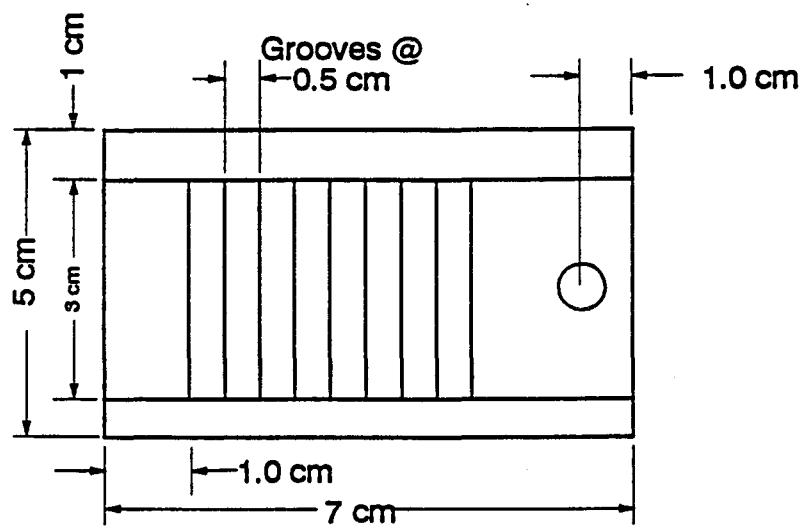

Figure 2.1. Schematic diagram of a ceramic *Fucus* recruitment tile and the vixar cage used to manipulate herbivores. To control for cage effects the cable ties were left off of one end of the vixar cage such that that end of the cage was open to herbivores.

Schematic of Fucus Egg Settling Plate



Typical Cross Section Through Groove

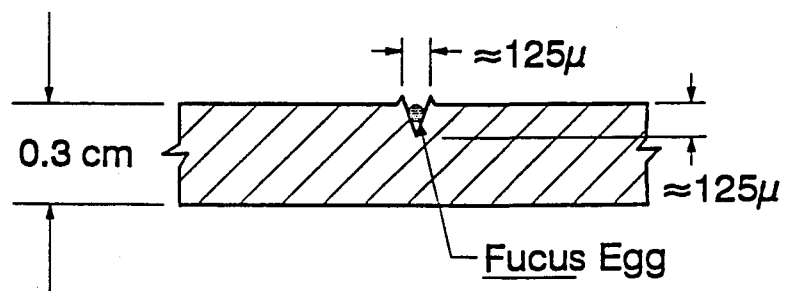

Figure 2.2. Schematic diagram of a *Fucus* egg catcher plate.

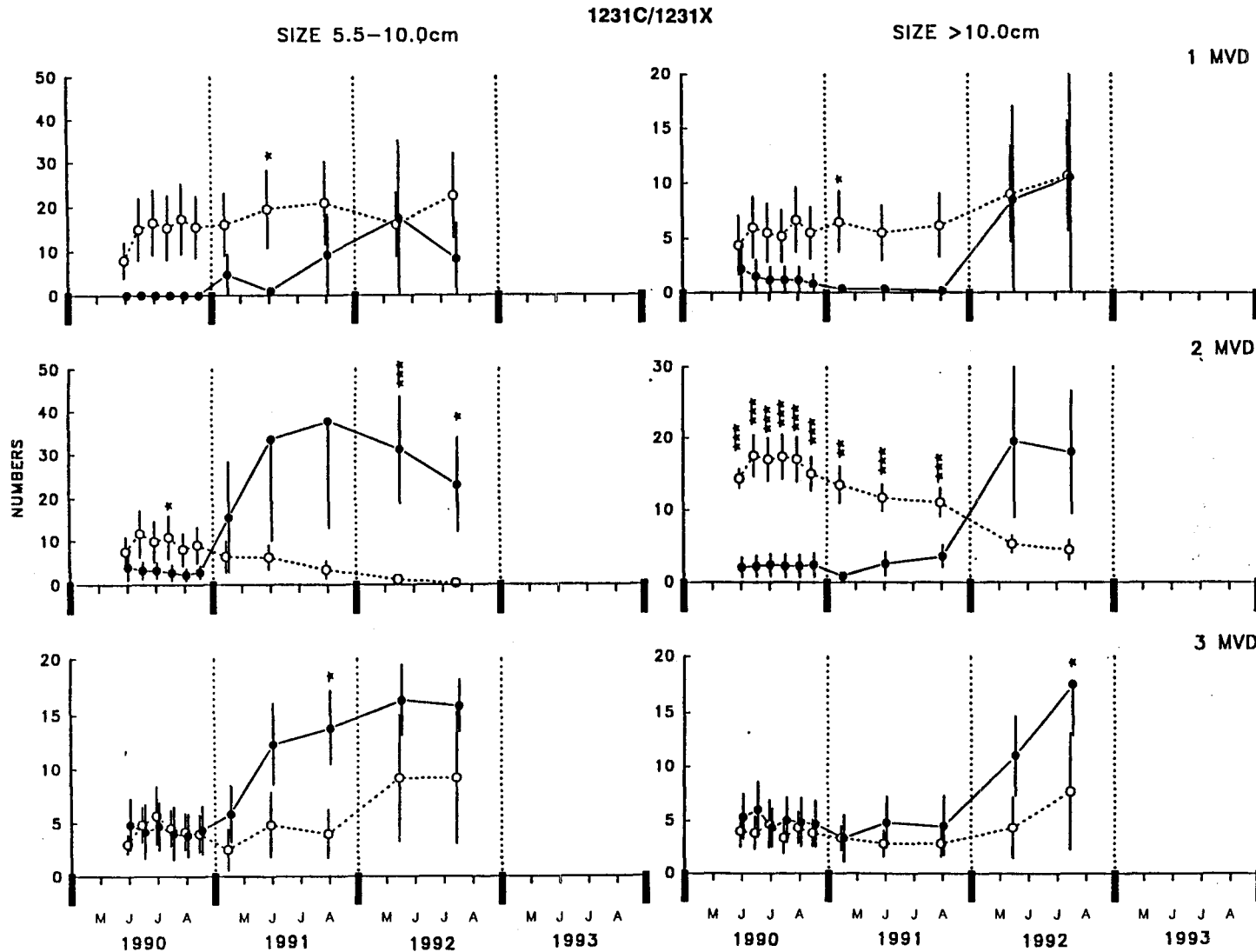

Figure 2.3. The number of medium (5.5-10 cm) and large (>10 cm) *Fucus* plants at the 1231C/1231X site pair. The oiled site is represented by solid circles and lines, and the control site is represented by open circles and dashed lines. The upper 2 graphs are for the first MVD, the middle graphs for the second MVD and bottom graphs for the third MVD. The error bars represent one standard error of the mean. The vertical dashed lines represent divisions between field seasons which ran from May (M on the x-axis) through August (A). Winter months are not represented on the graphs. Stars indicate statistically significant differences between oiled and

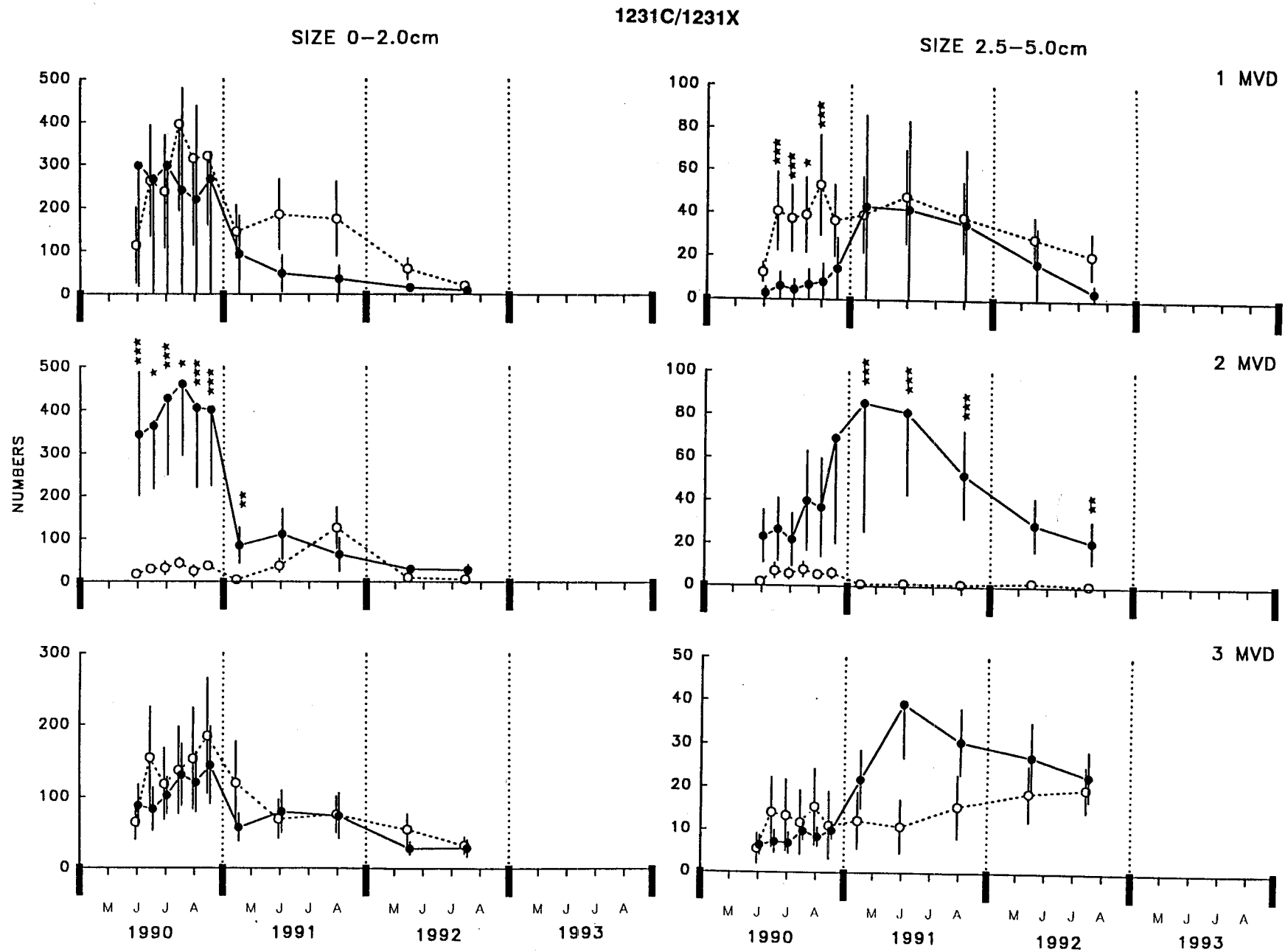

Figure 2.4. The number of *Fucus* germlings (0-2.0 cm) and small (2.5-5.0 cm) plants at the 1231C/1231X site near. Layout is the same as Figure 2.2

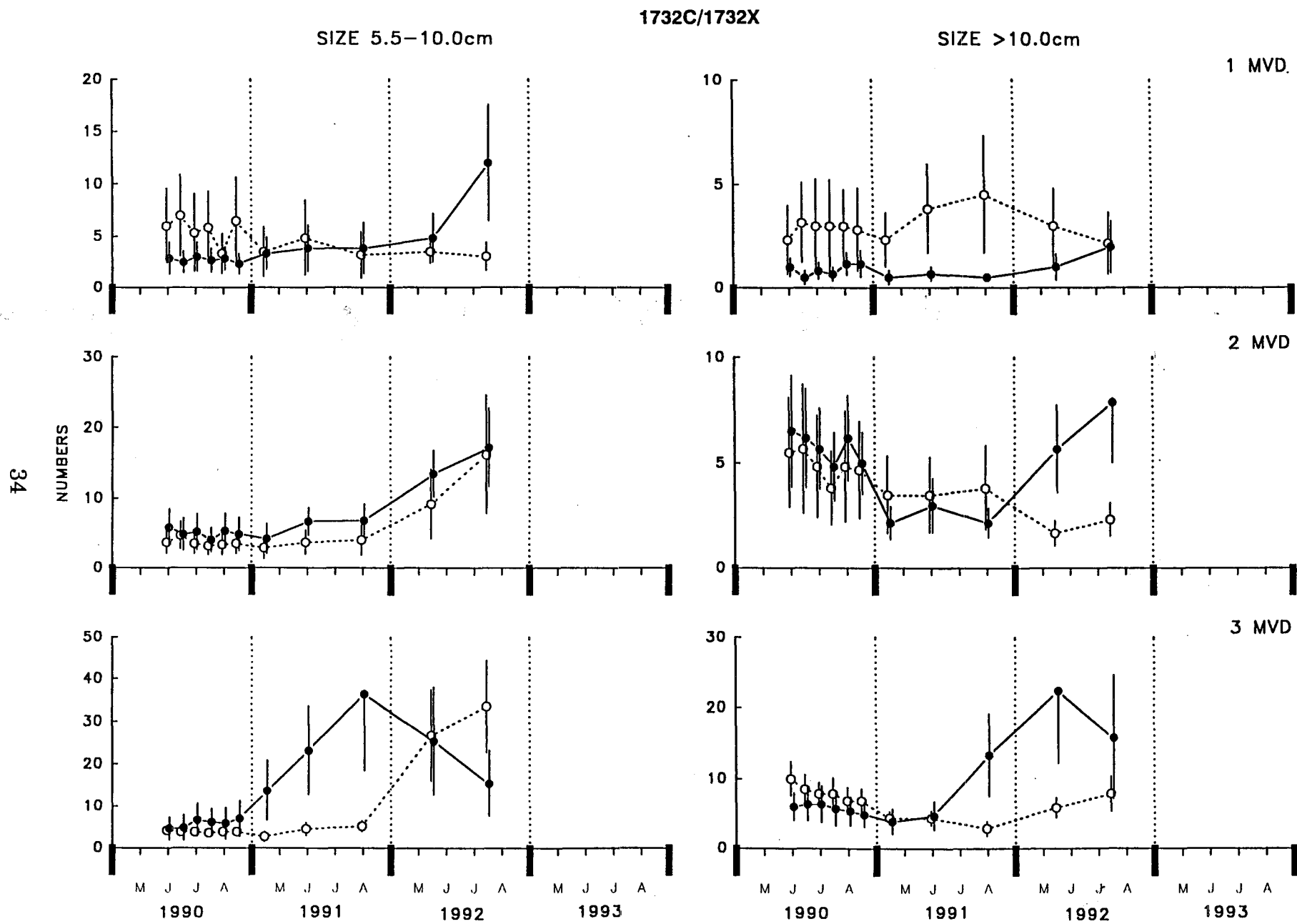

Figure 2.5. The number of medium and large *Fucus* plants at the 1732C/1732X site pair. Layout is the same as

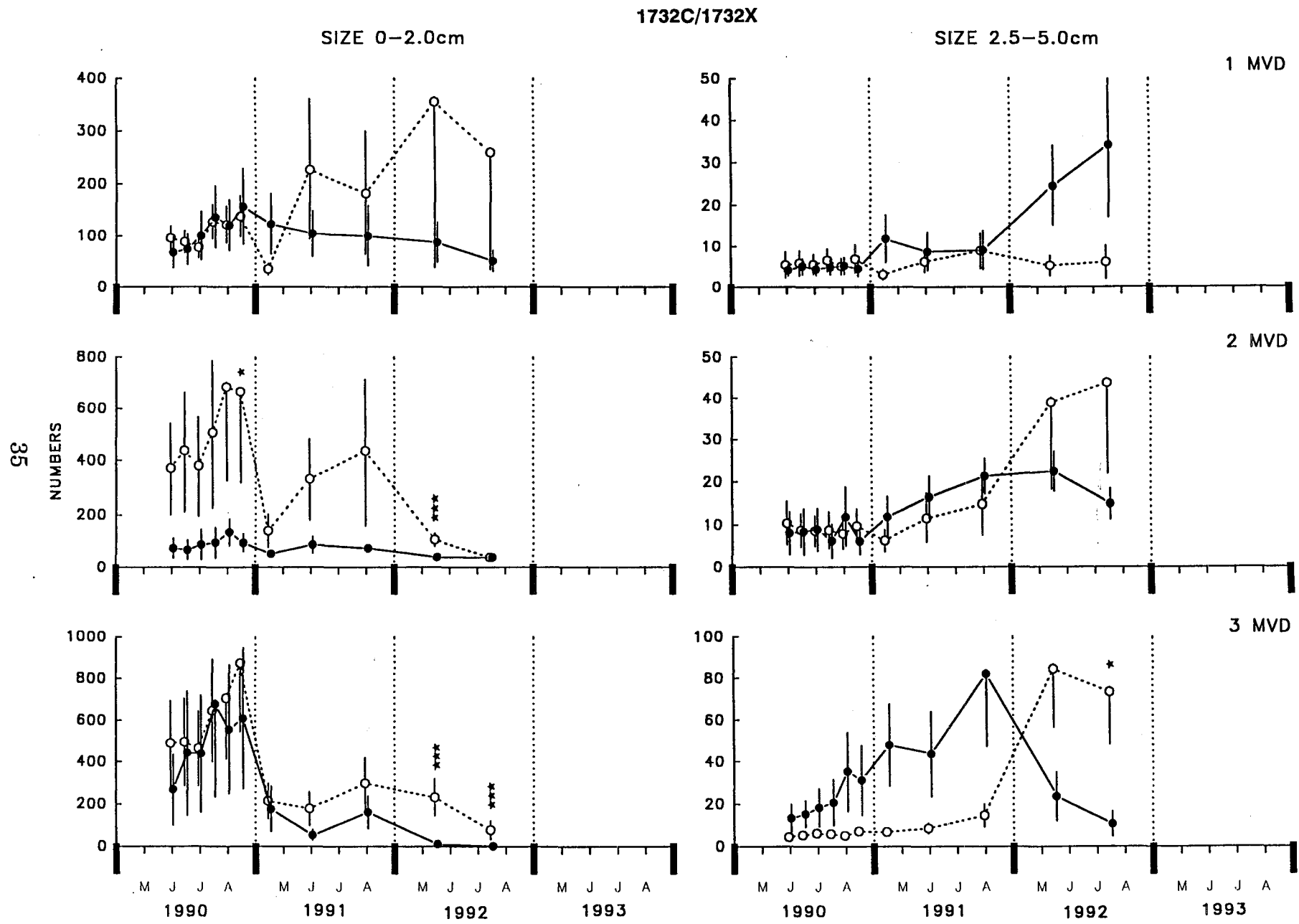

Figure 2.6. The number of *Fucus* germlings and small plants at the 1732C/1732X site pair. Layout is the same as

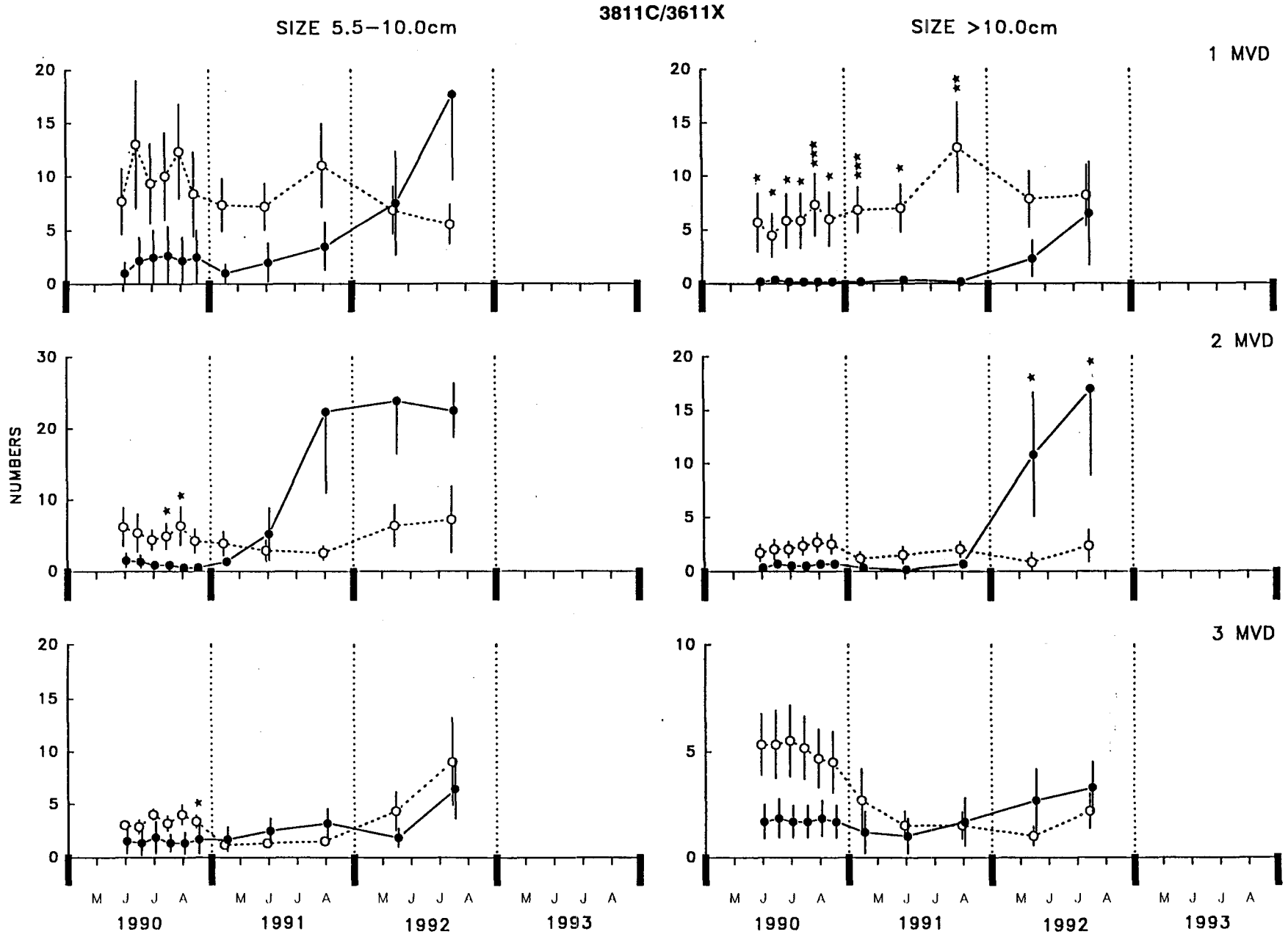

Figure 2.7. The number of medium and large *Fucus* plants at the 3811C/3611X site pair. Lavout is the same as

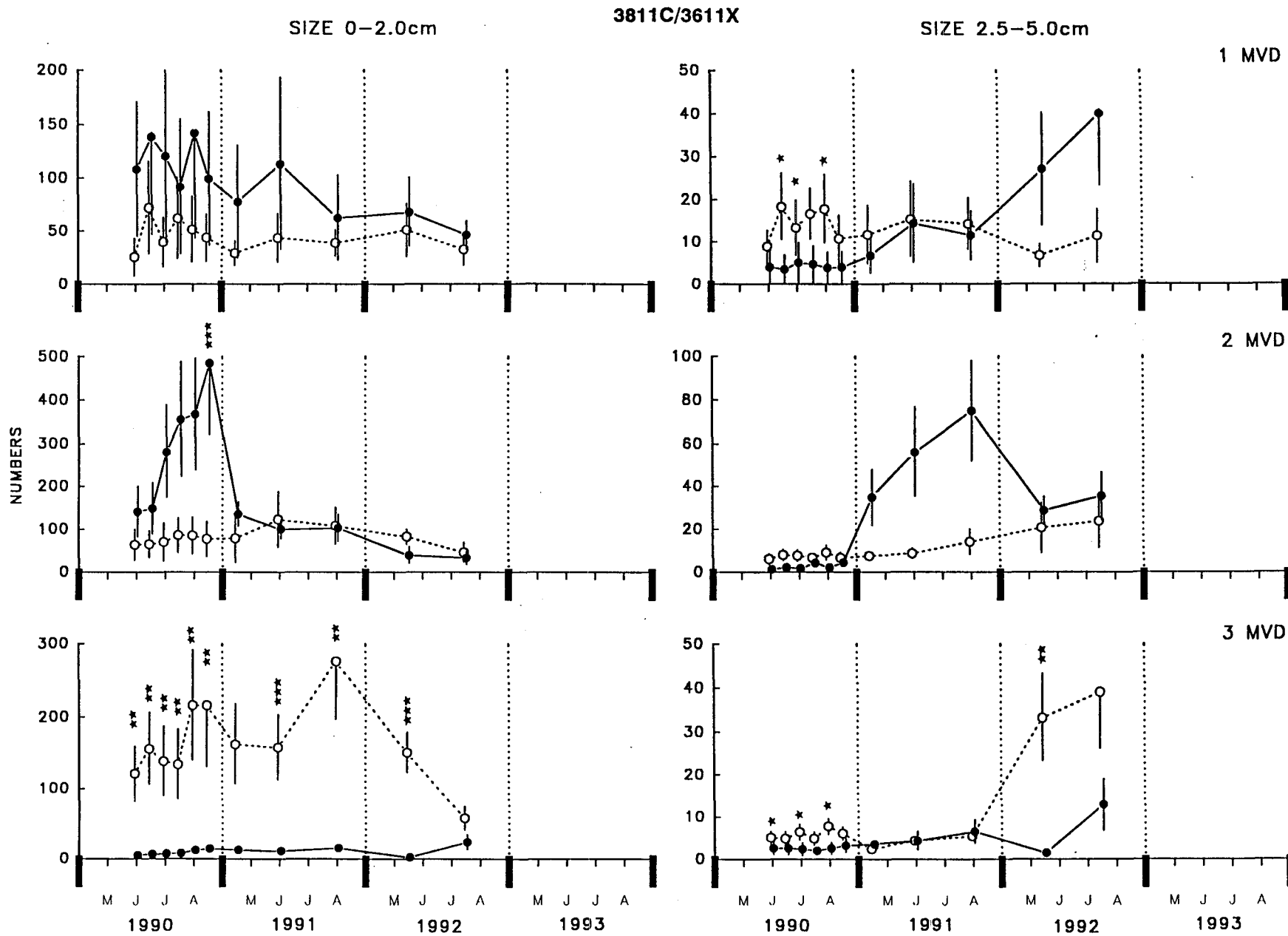

Figure 2.8. The number of *Fucus* germlings and small plants at the 3811C/3611X site pair. Event is the same

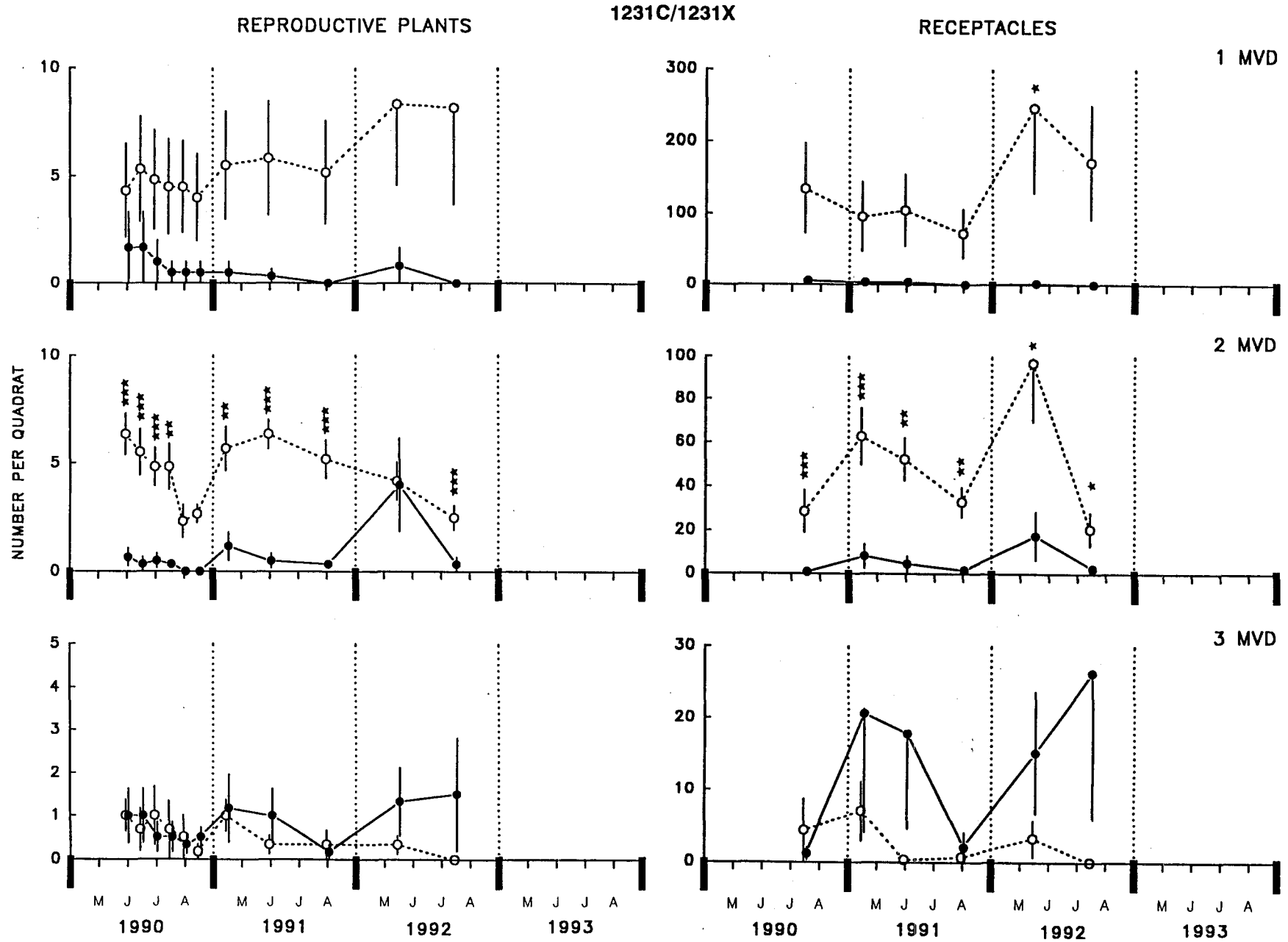

Figure 2.9. The number of reproductive *Fucus* plants and receptacles per quadrat at the 1231C/1231X site pair.

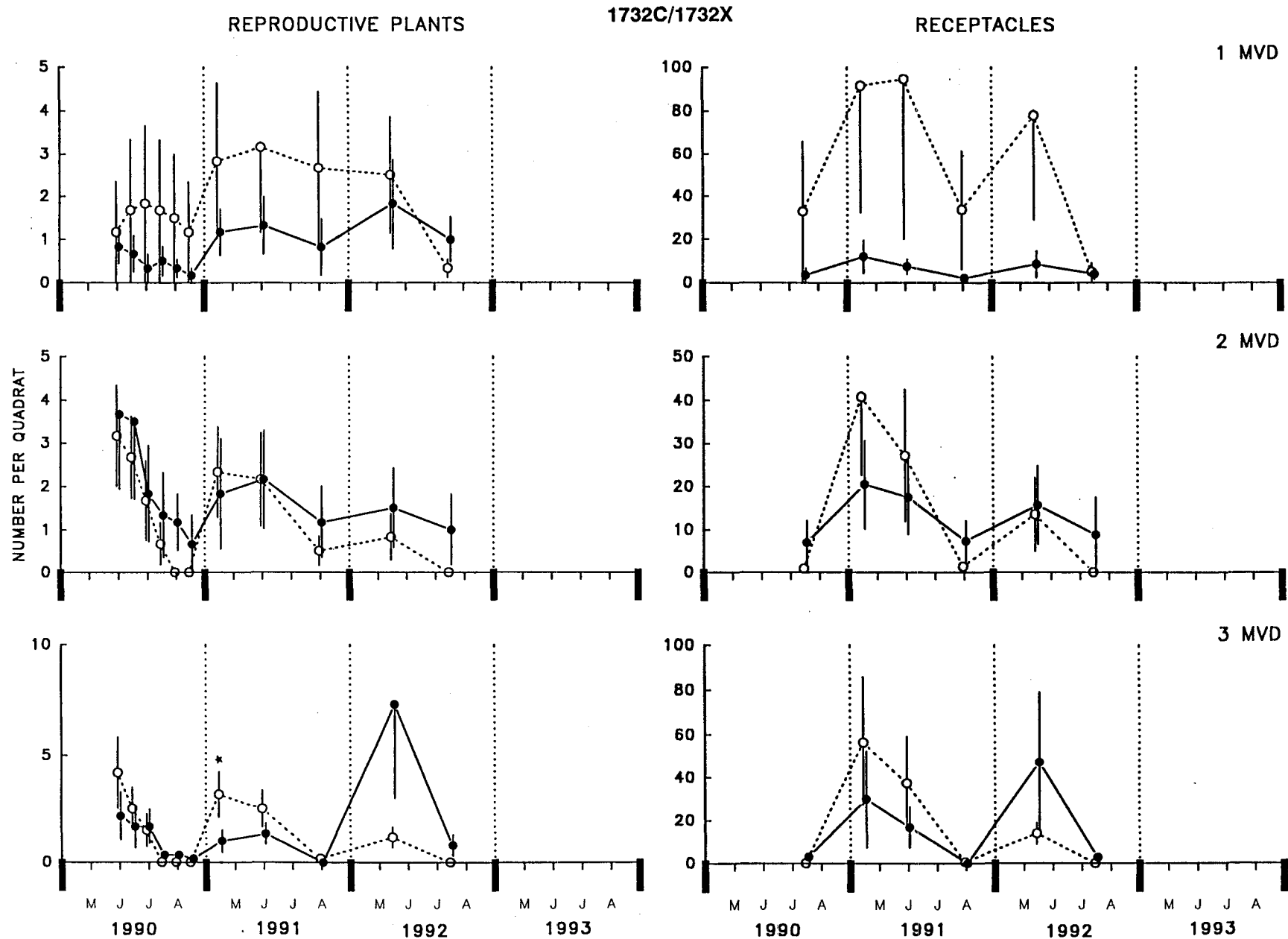

Figure 2.10. The number of reproductive *Fucus* plants and receptacles per quadrat at the 1732C/1732X site pair. Layout is the same as Figure 2.9.

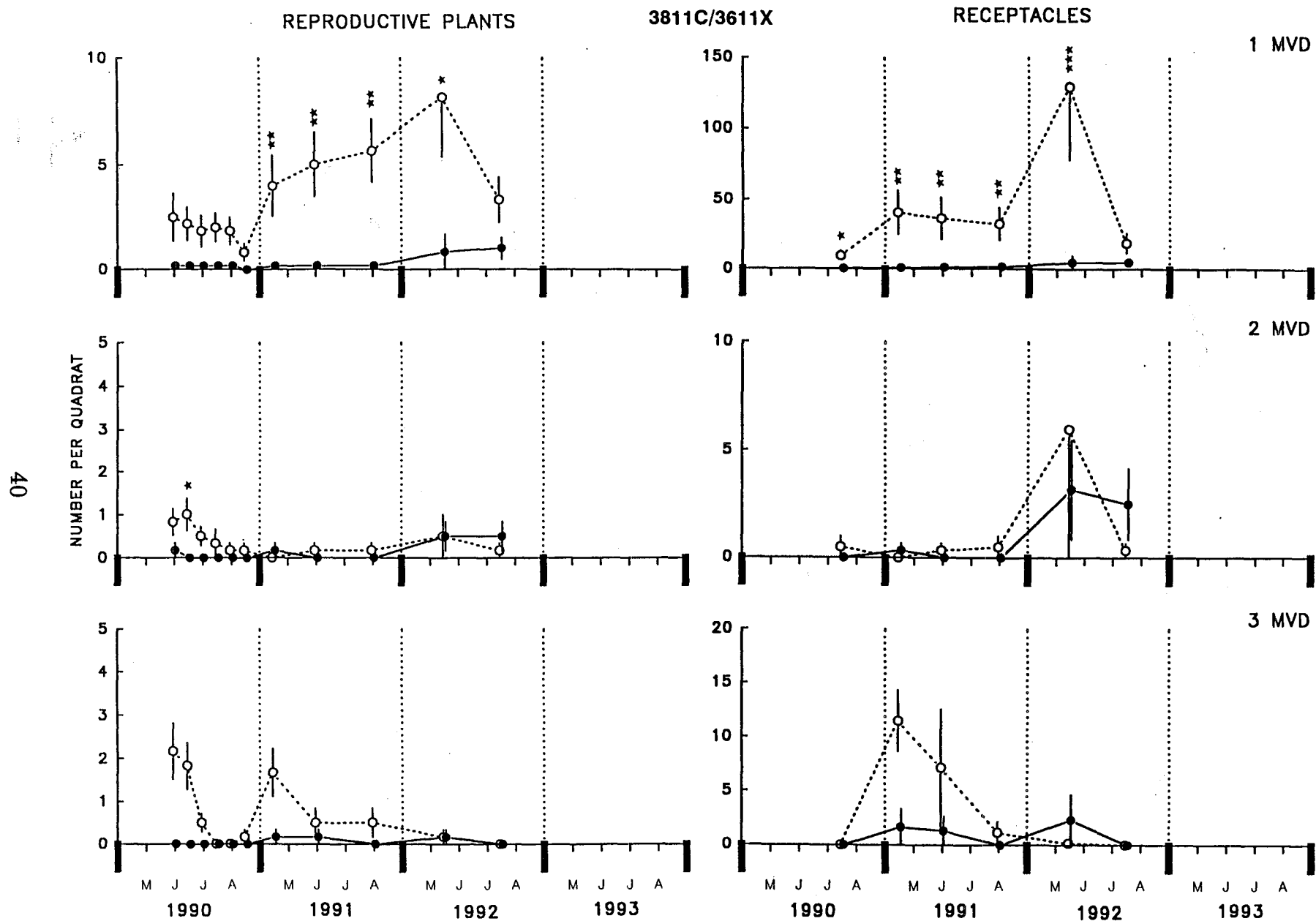

Figure 2.11. The number of reproductive *Fucus* plants and receptacles per quadrat at the 3811C/3611X site pair. Layout is the same as Figure 2.3.

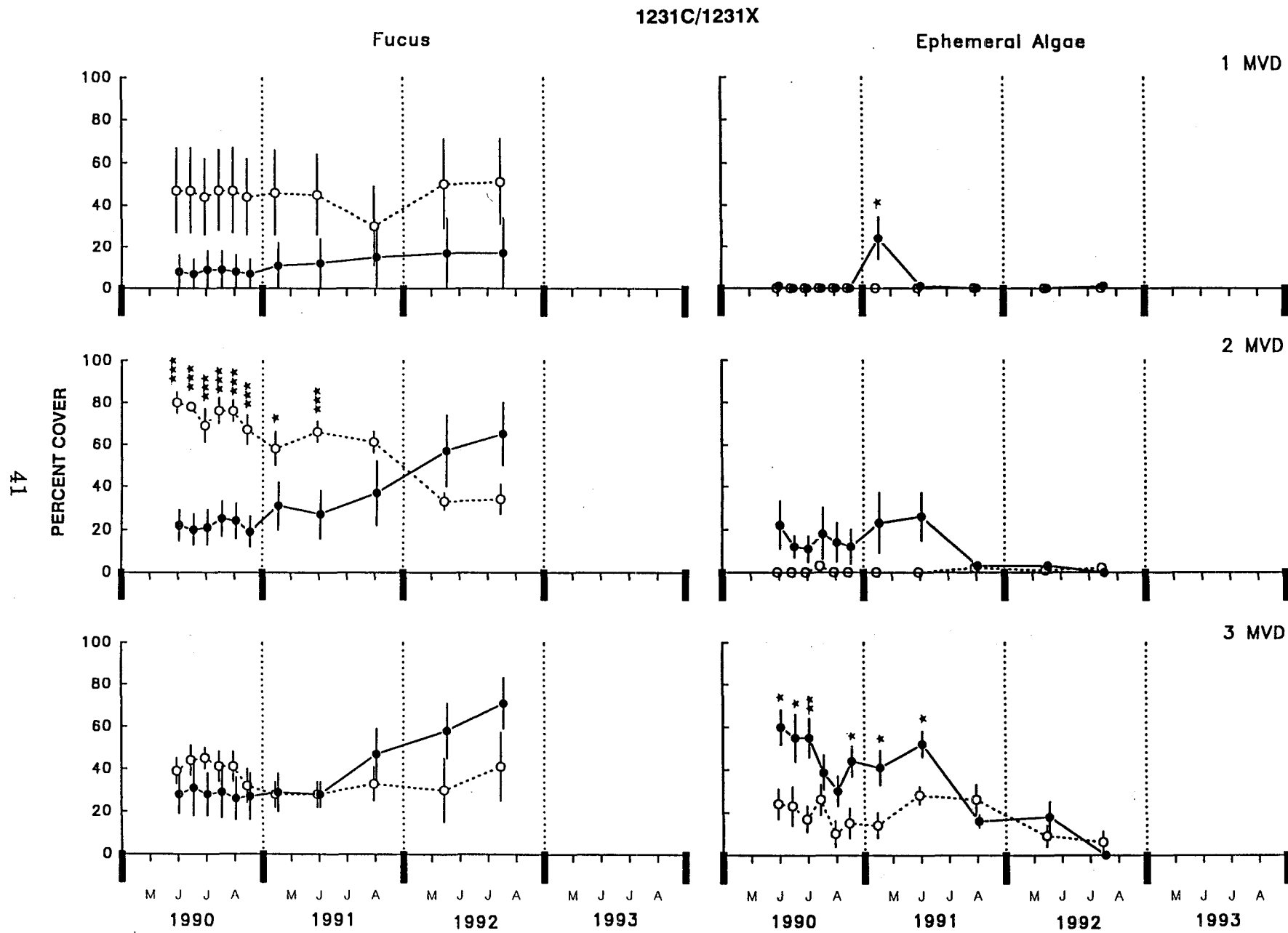

Figure 2.12. The percent cover of *Fucus* and ephemeral algae at the 1231C/1231X site pair. Layout is the same

1732C/1732X

Fucus

Ephemeral Algae

1 MVD

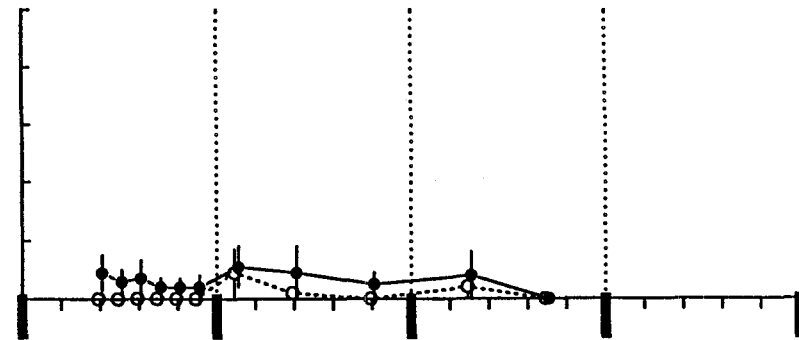
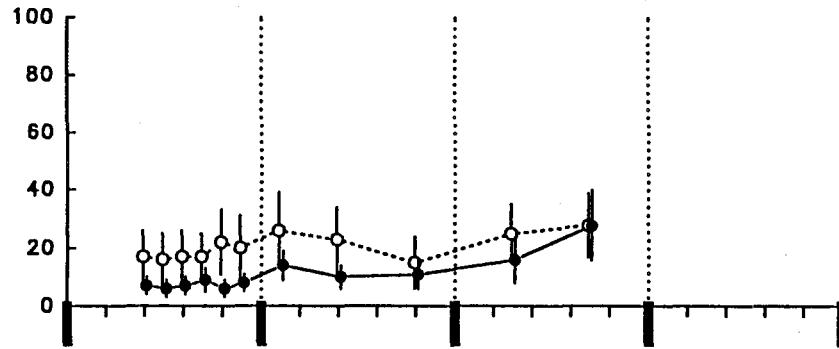

2 MVD

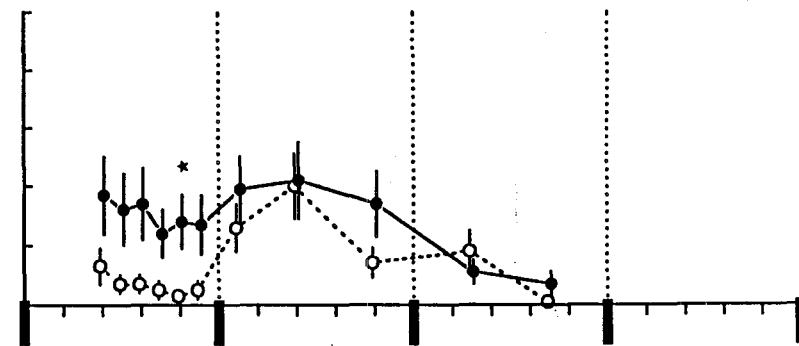
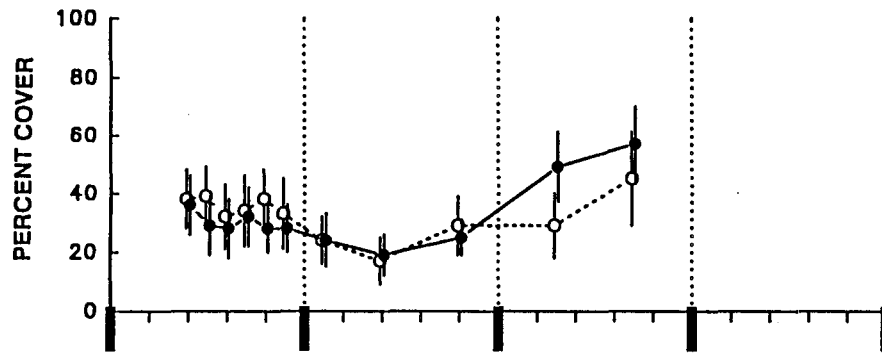

3 MVD

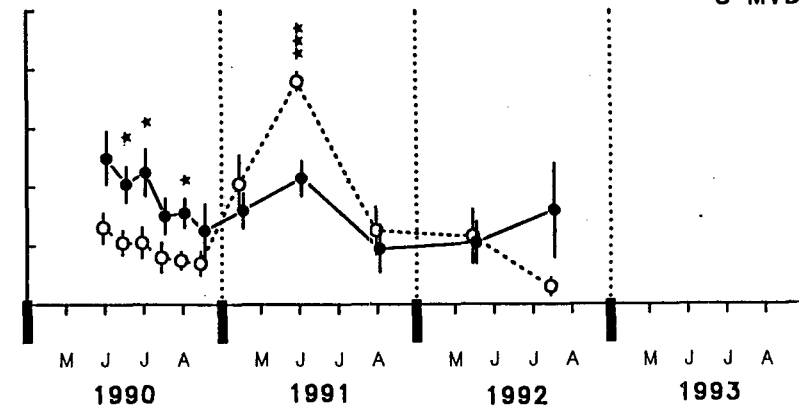
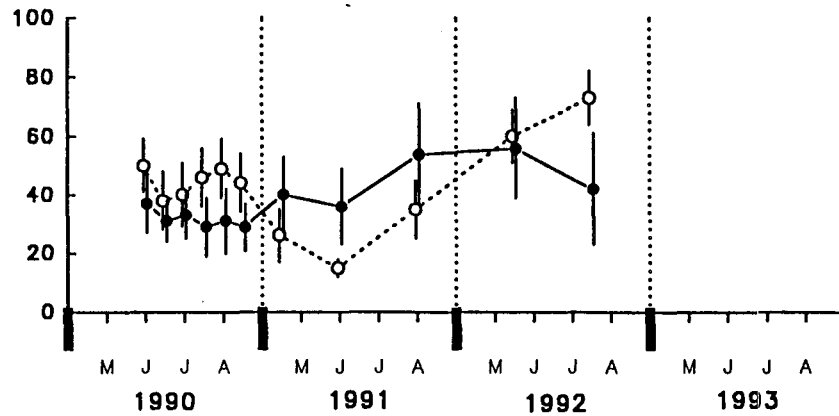

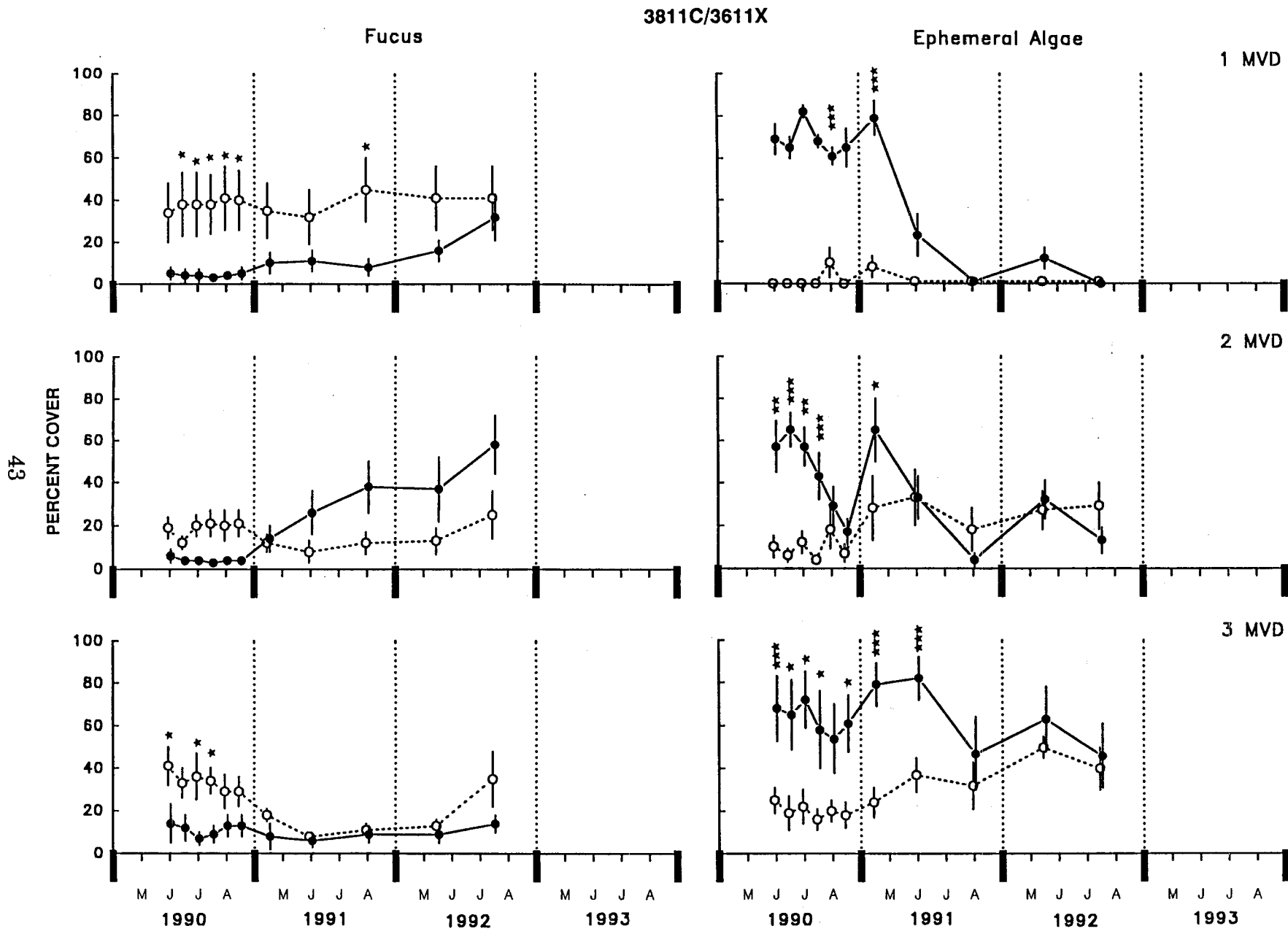

Figure 2.14. The percent cover of *Fucus* and ephemeral algae at the 3811C/3611X site pair. Layout is the same

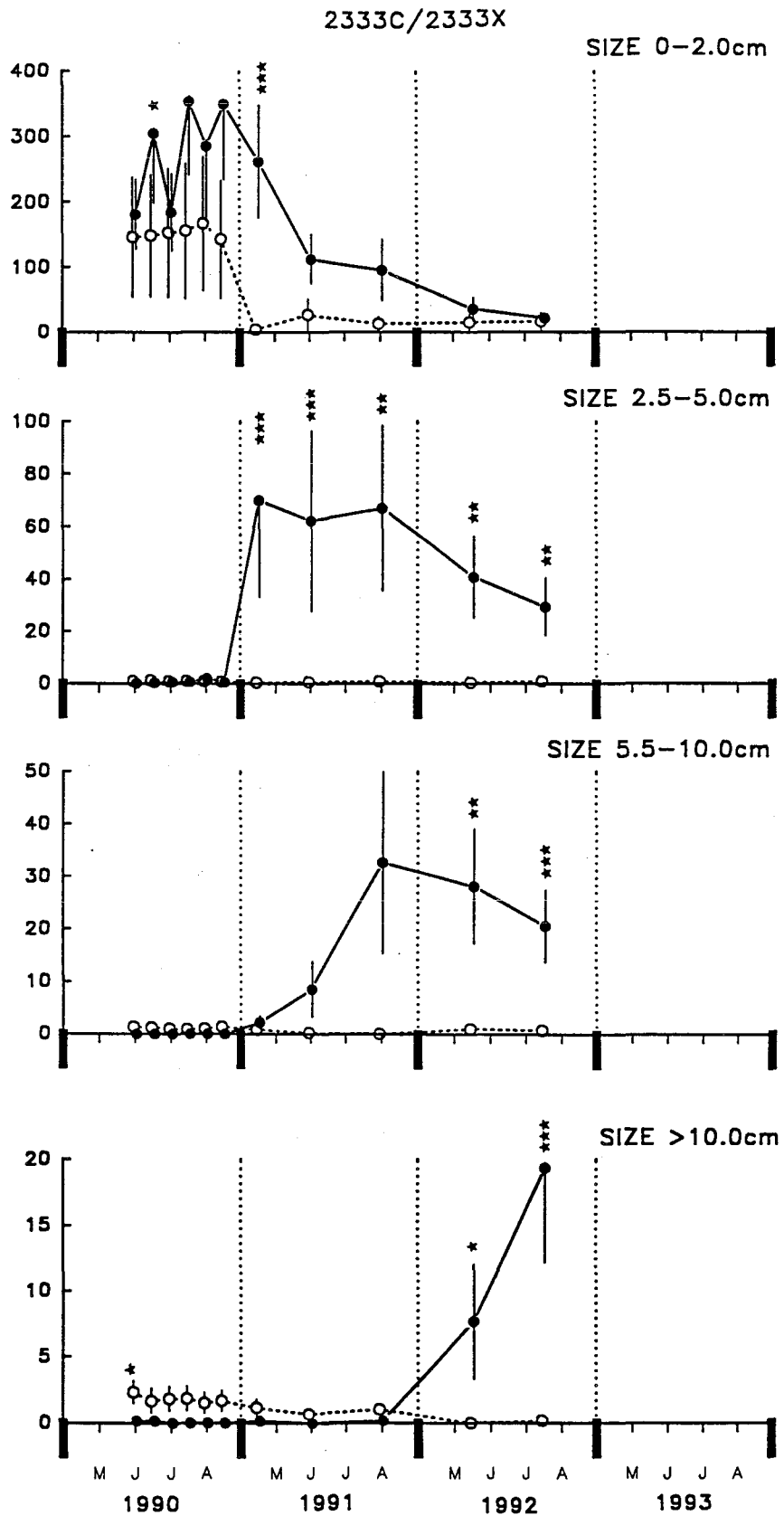

Figure 2.15. The number of *Fucus* plants in the four size classes in the third MVD at the 2333C/2333X site pair. Layout is the same as Figure 2.3.

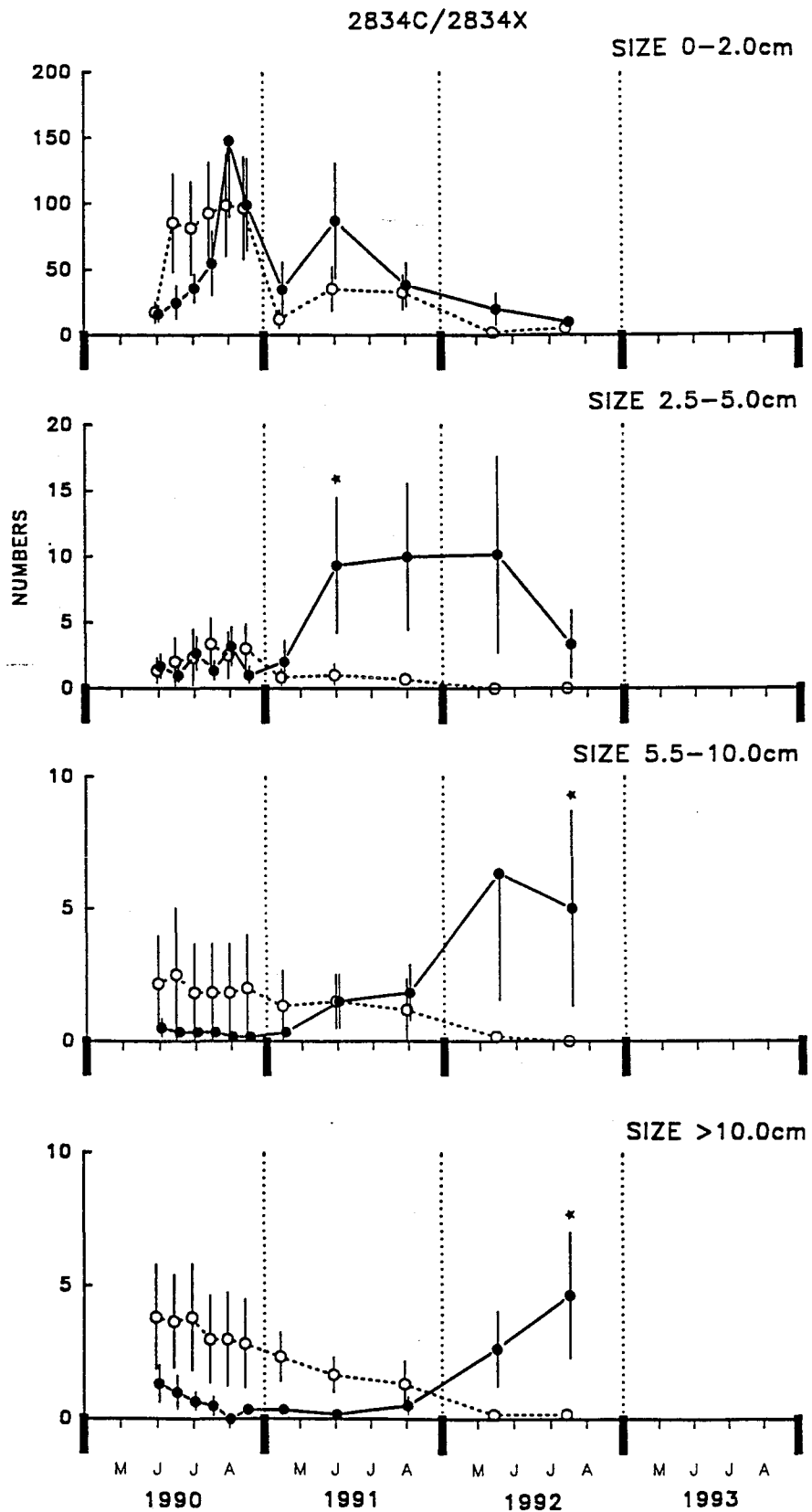

Figure 2.16. The number of *Fucus* plants in the four size classes in the third MVD at the 2834C/2834X site pair. Layout is the same as Figure 2.3.

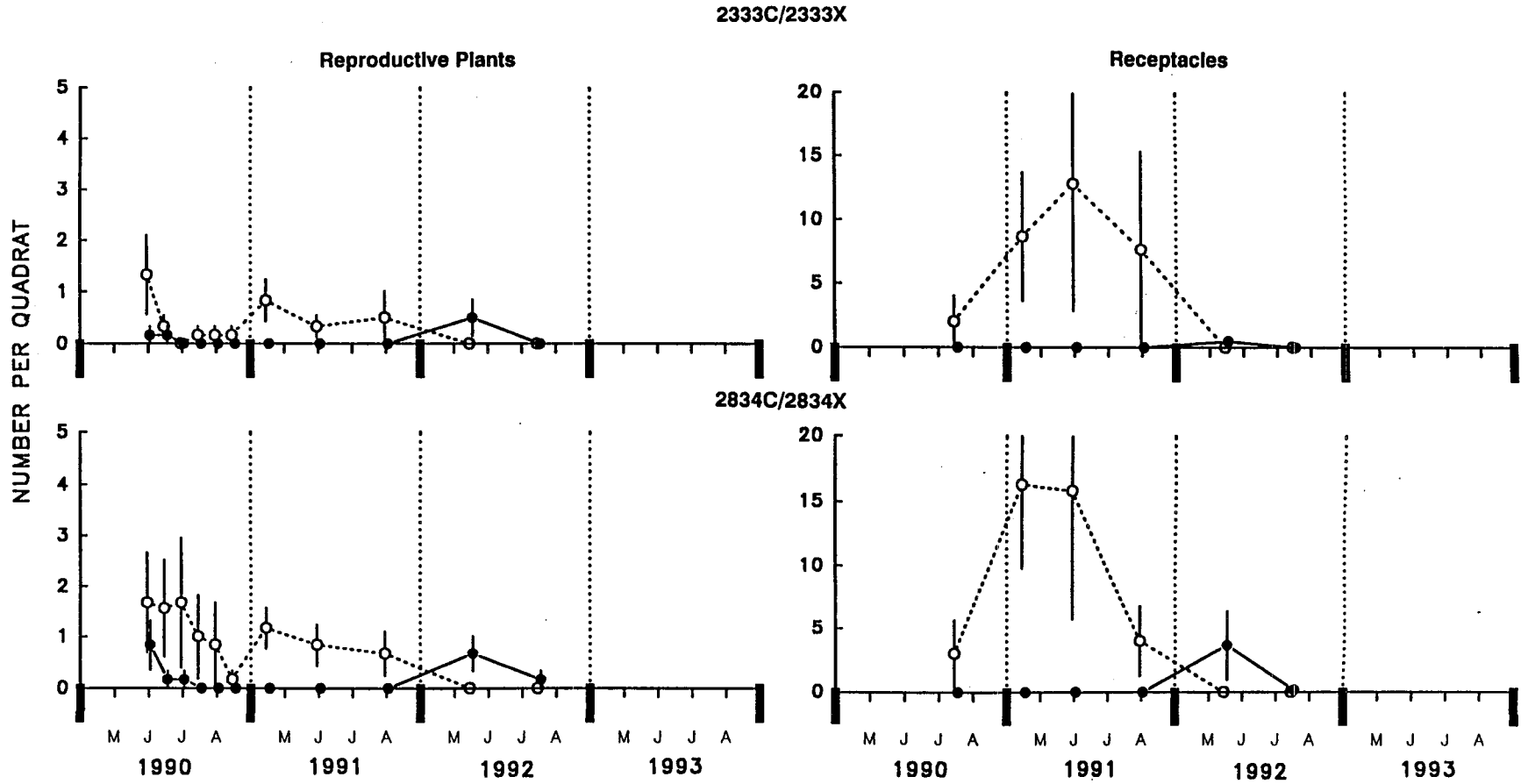

Figure 2.17. The number of reproductive *Fucus* plants and receptacles per quadrat at the coarse textured site pairs. Layout is the same as Figure 2.3.

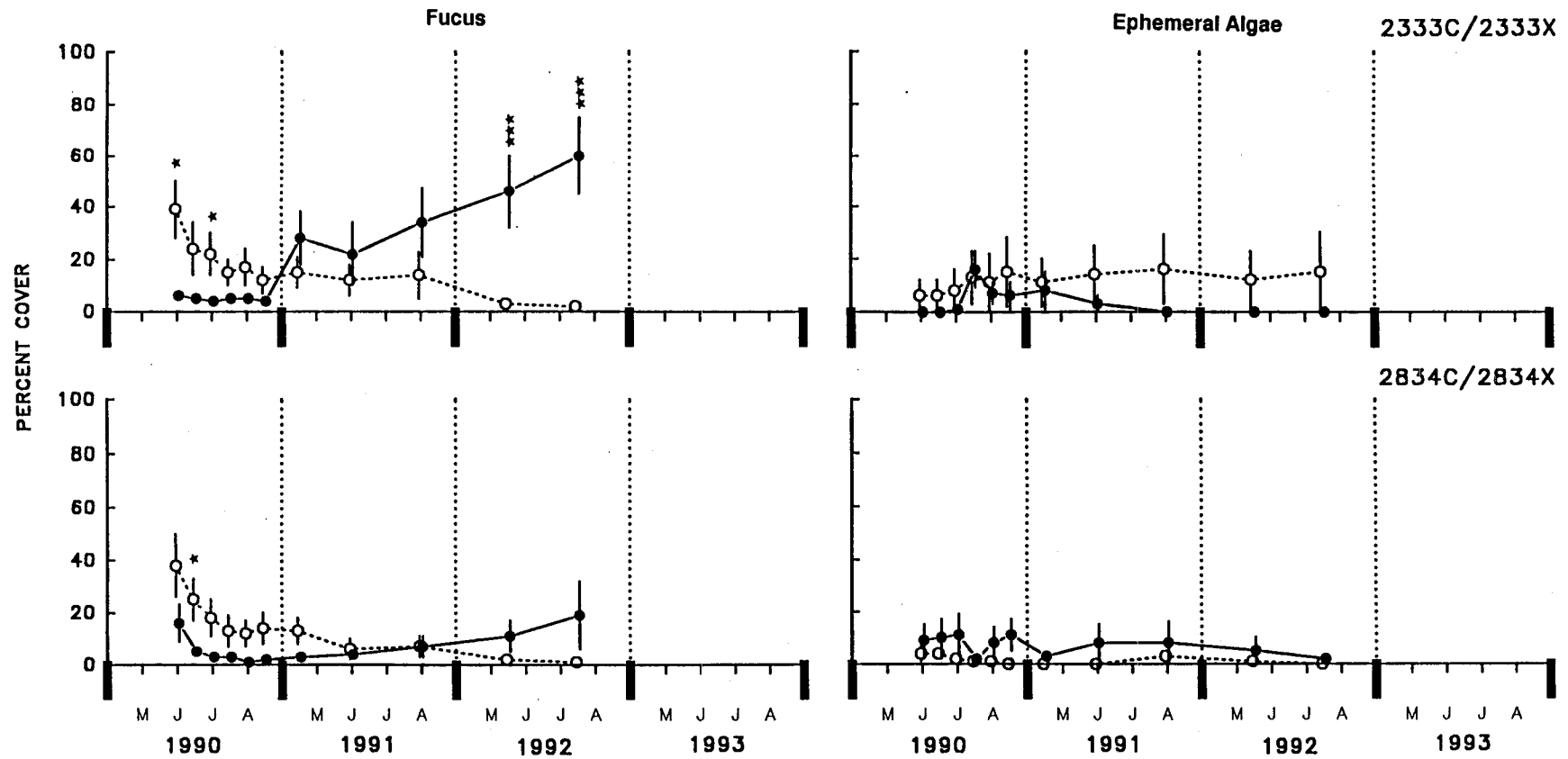

Figure 2.18. The percent cover of *Fucus* and ephemeral algae in the third MVD at the coarse textured site pairs. Layout is the same as Figure 2.3.

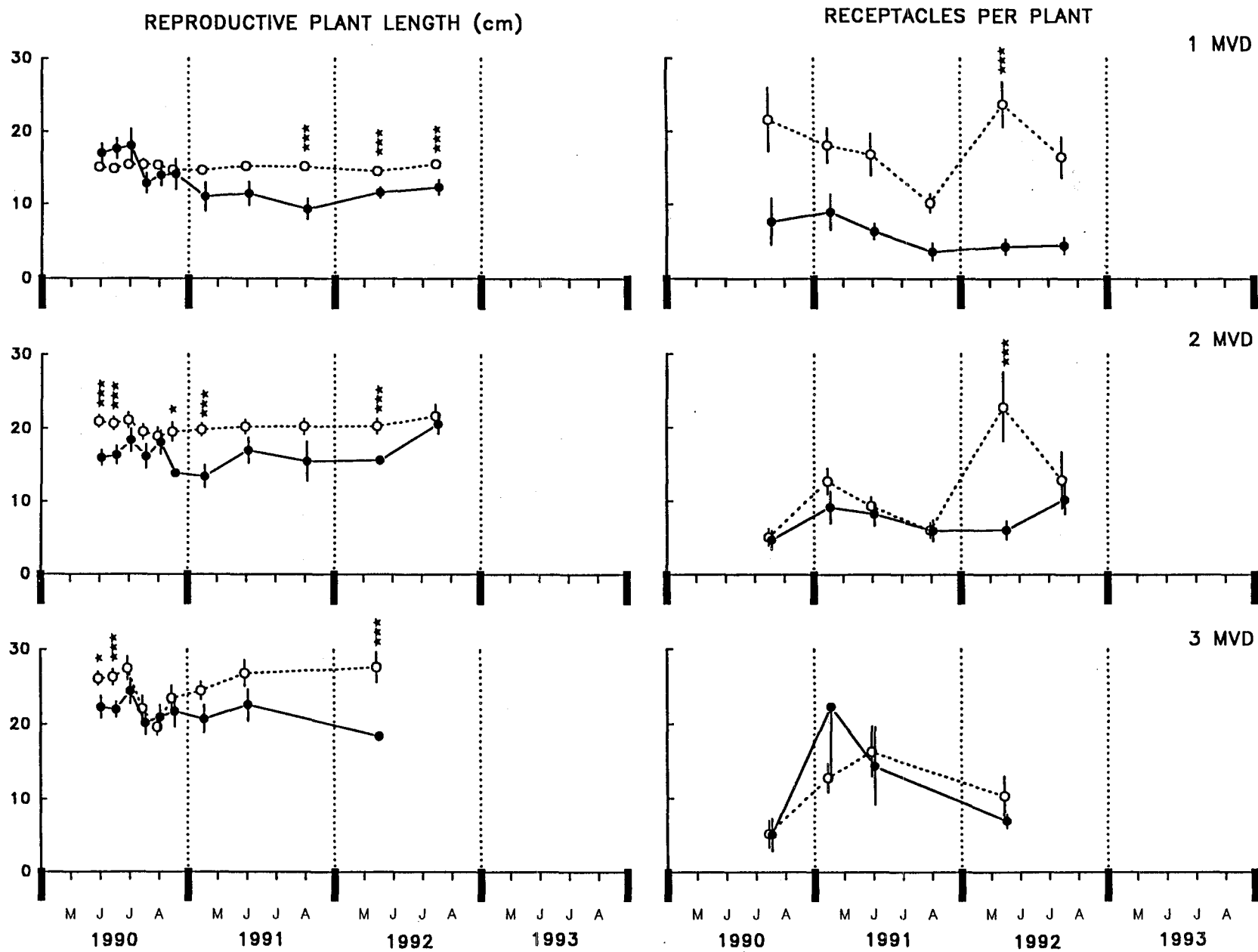

Figure 2.19. The average length and number of receptacles per plant for all reproductive *Fucus* plants at all five site pairs sampled. The top graphs are for the first MVD, the middle graphs for the second MVD, and the bottom

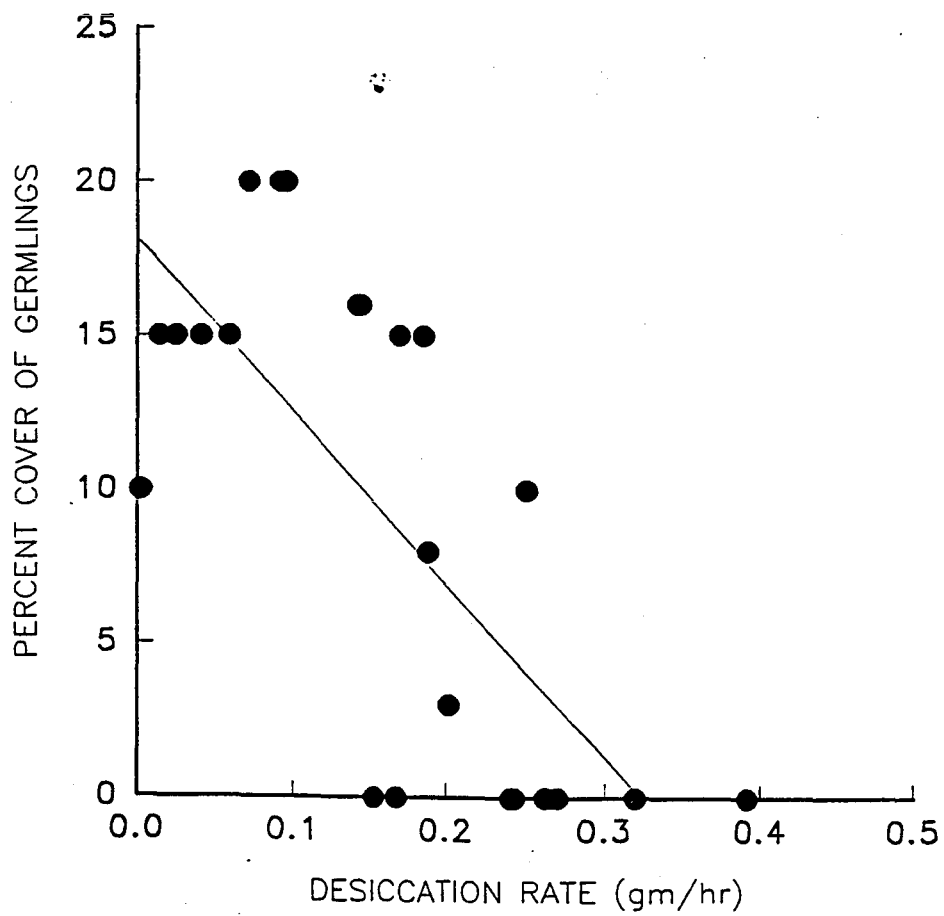

Figure 2.20. The relationship between the measured desiccation rate and the estimated percent cover of *Fucus* on the petri dish plates after being in the field for two weeks. The regression is significant ($r^2=0.524$, $df=22$, $F=24.178$, $p<0.001$).

INITIAL SEEDING DENSITIES

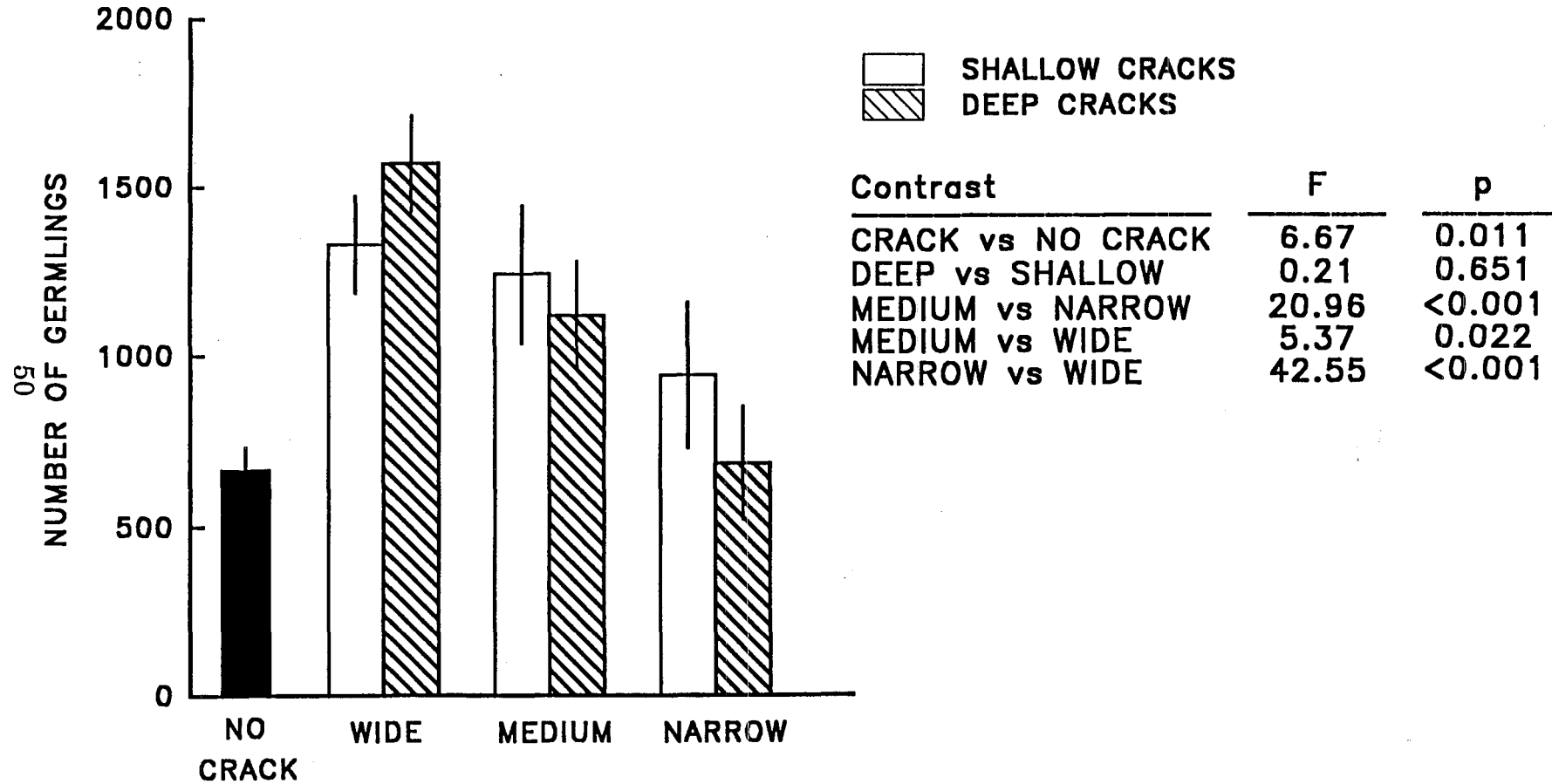

Figure 2.21. The number of germlings in the various sized cracks and out of cracks on the seeded ceramic tiles before they were placed in the field.

PERCENT SURVIVAL OF GERMLINGS

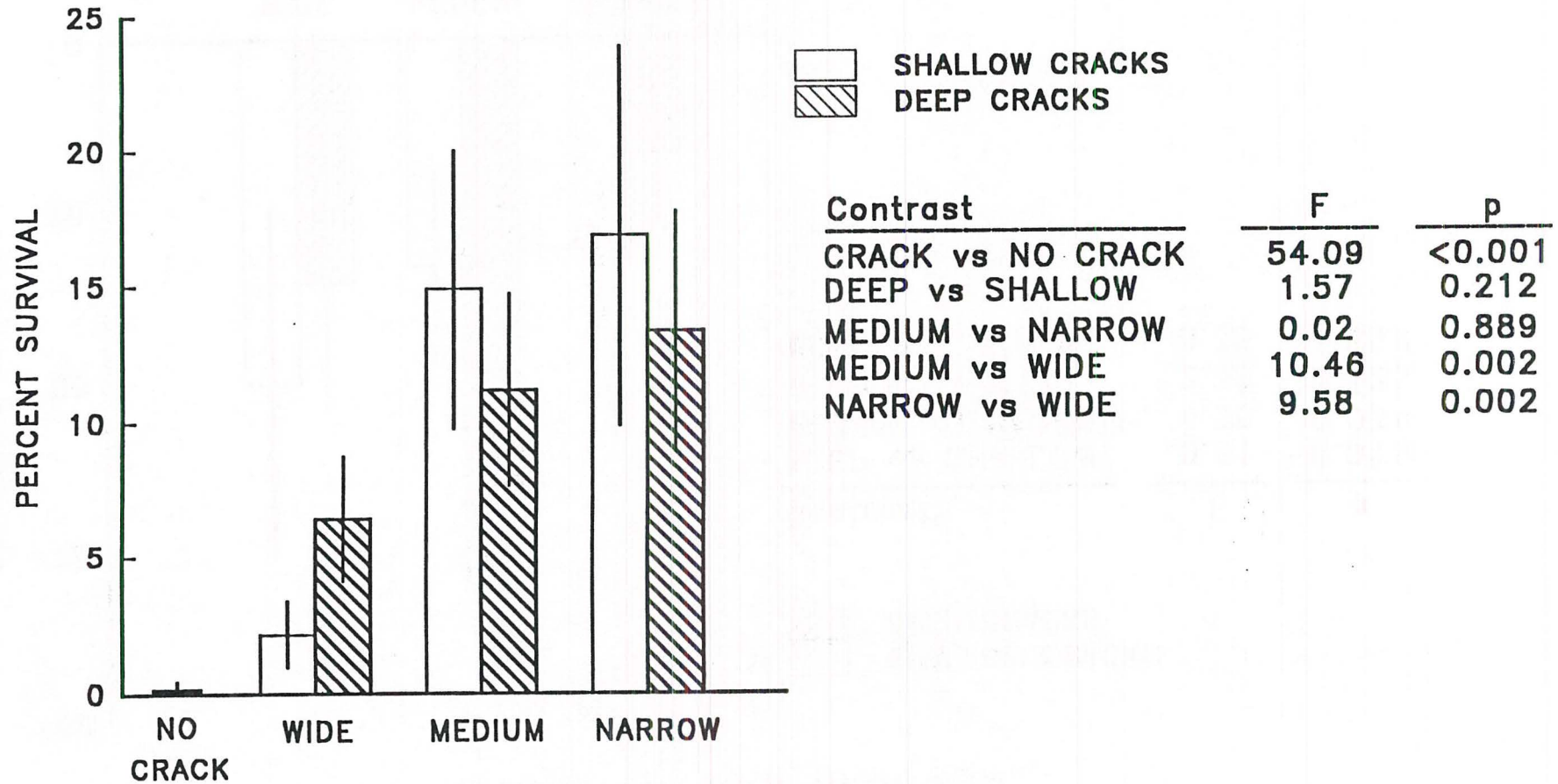

Figure 2.22. The percent survival of germlings, final densities divided by initial densities, in the various sized cracks and out of cracks on seeded tiles after two months in the field.

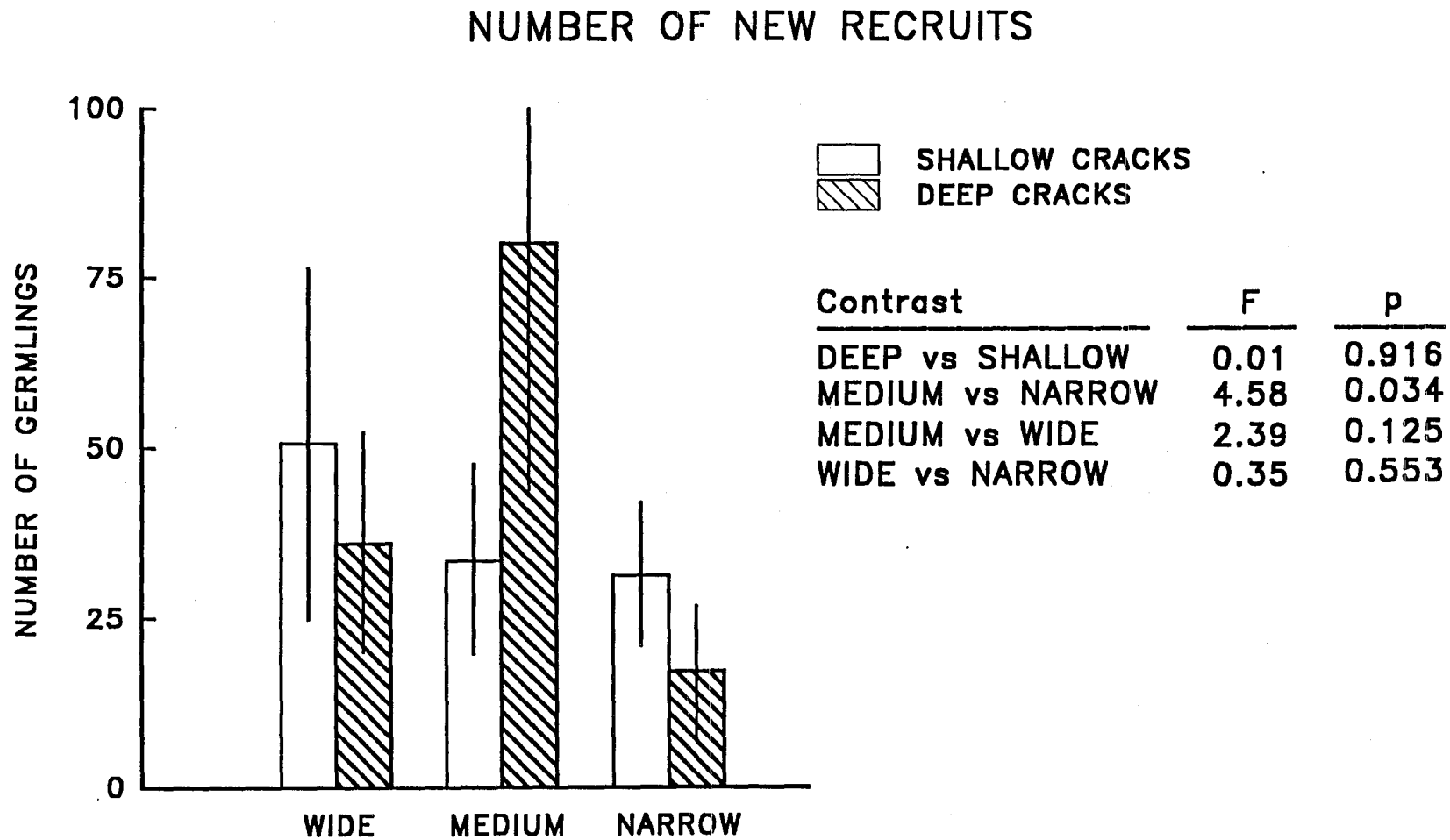

Figure 2.23. The number of new recruits in the various sized grooves on the unseeded tiles after two months in the field.

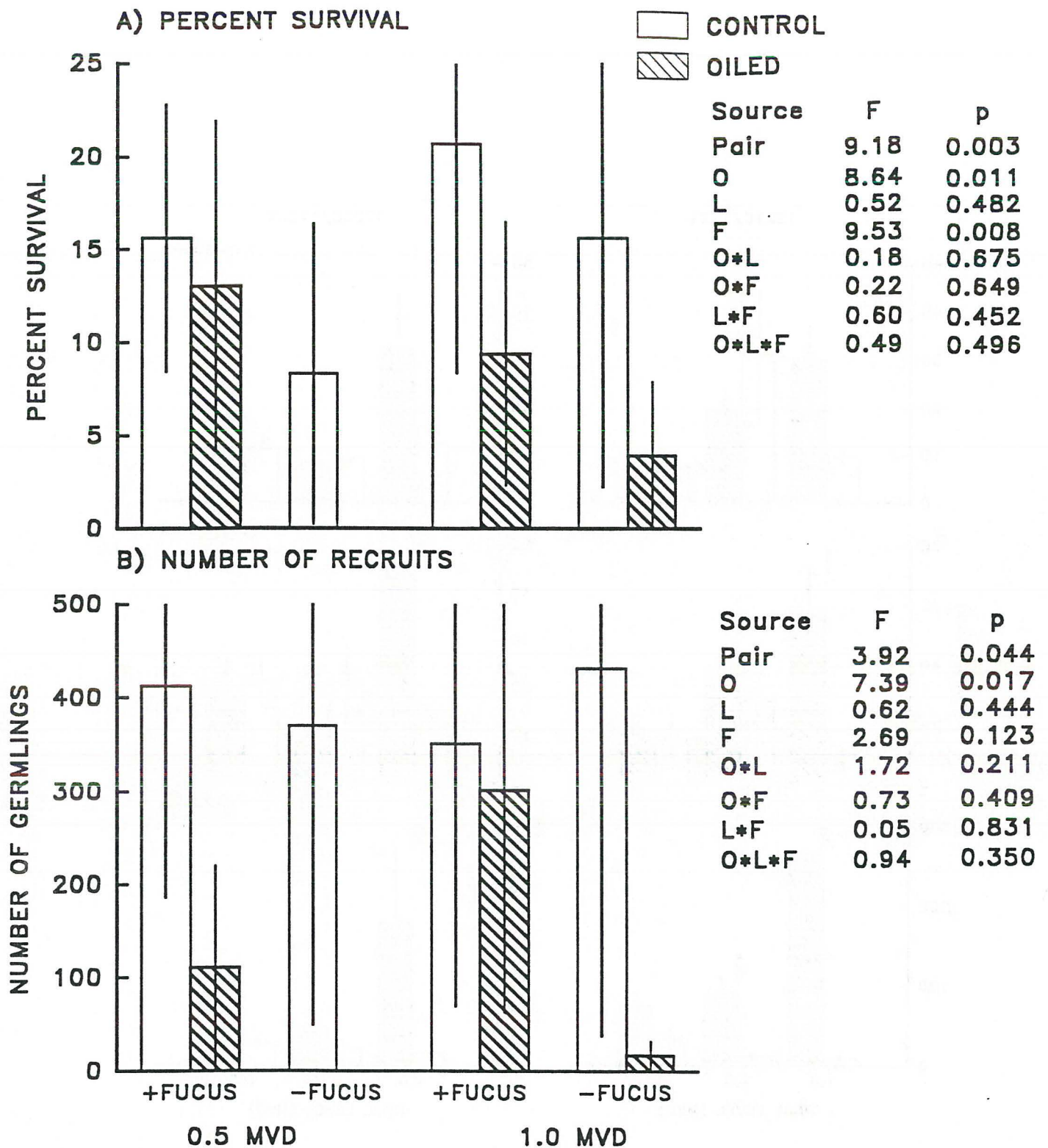

Figure 2.24. The percent survival on seeded tiles and number of new recruits on unseeded tiles with (+*Fucus*) and without (-*Fucus*) *Fucus* canopy, at the 0.5 MVD and 1.0 MVD tidal levels, and at oiled and control sites. The F and p values are given for the different treatments (O=Oil, L=Tidal Level, and F=*Fucus* canopy) and all of their interactions.

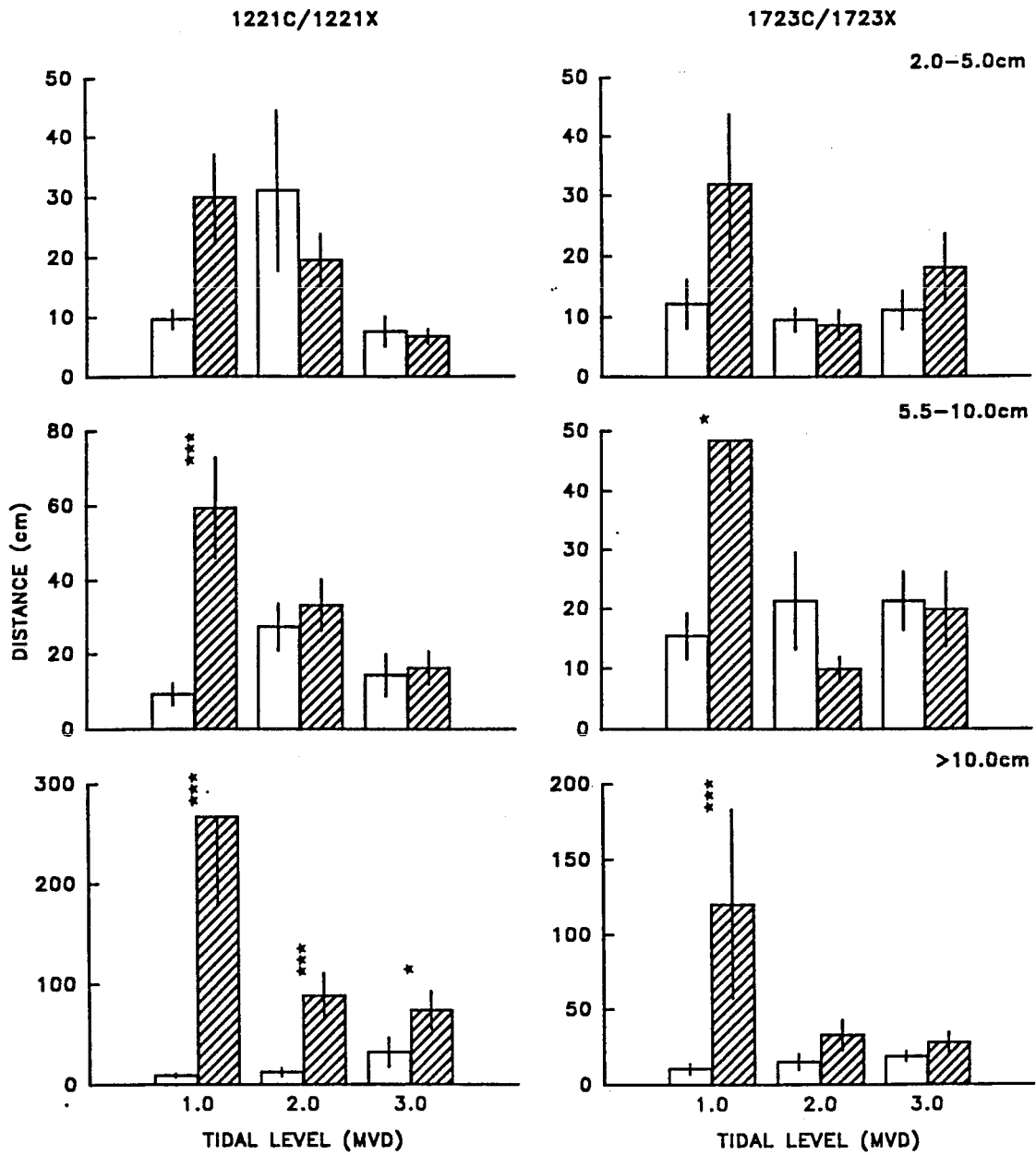

Figure 2.25. The distance to the nearest *Fucus* plant of three size classes at three tidal levels at two site pairs. Open bars are for control sites while hatched bars are for oiled sites. Error bars represent one standard error of the mean. Stars indicate statistically significant differences between oiled and control sites.

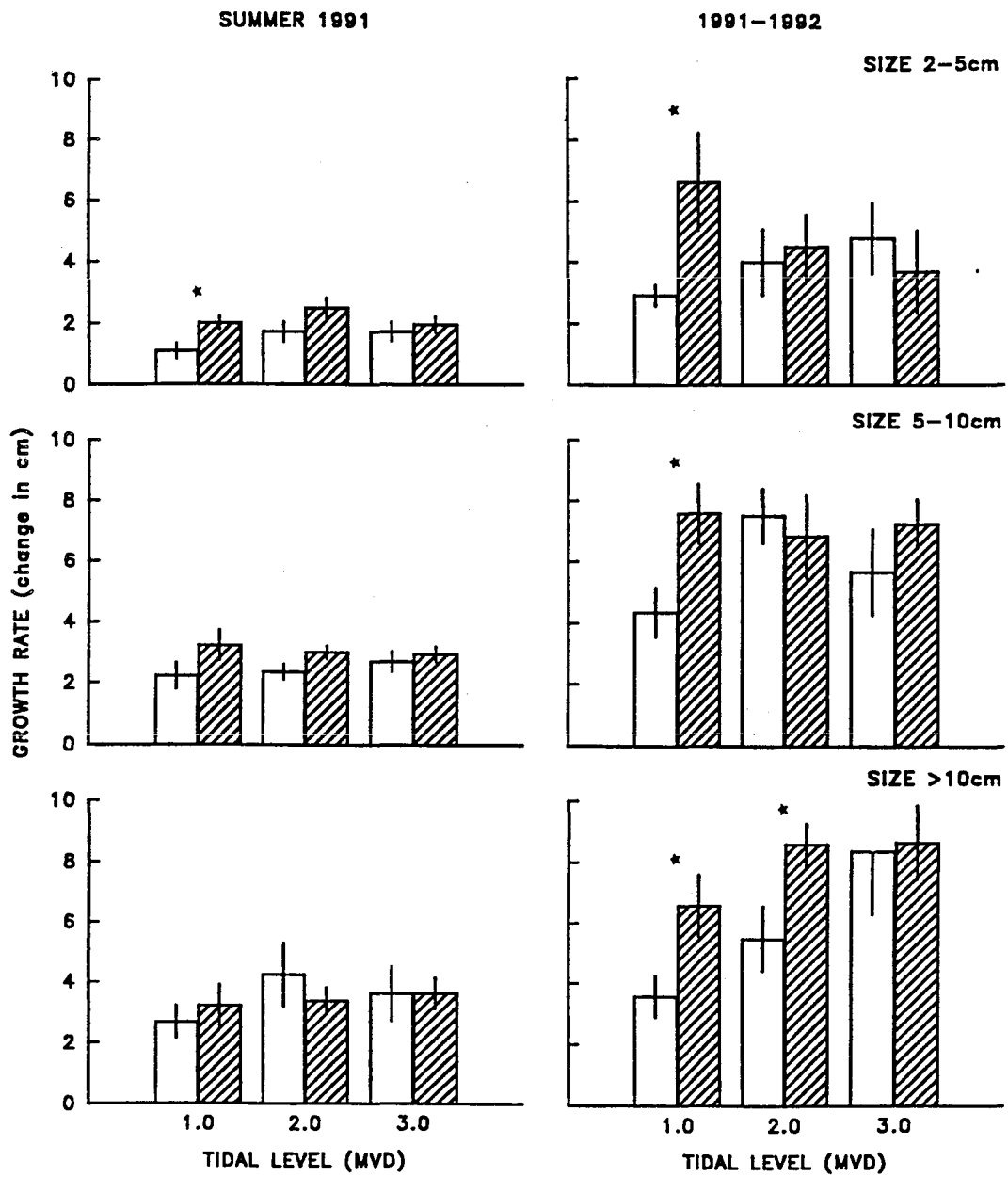

Figure 2.26. The growth rate of tagged plants in three size classes in the summer of 1991 and from summer 1991 to summer 1992. Layout is the same as Figure 2.25.

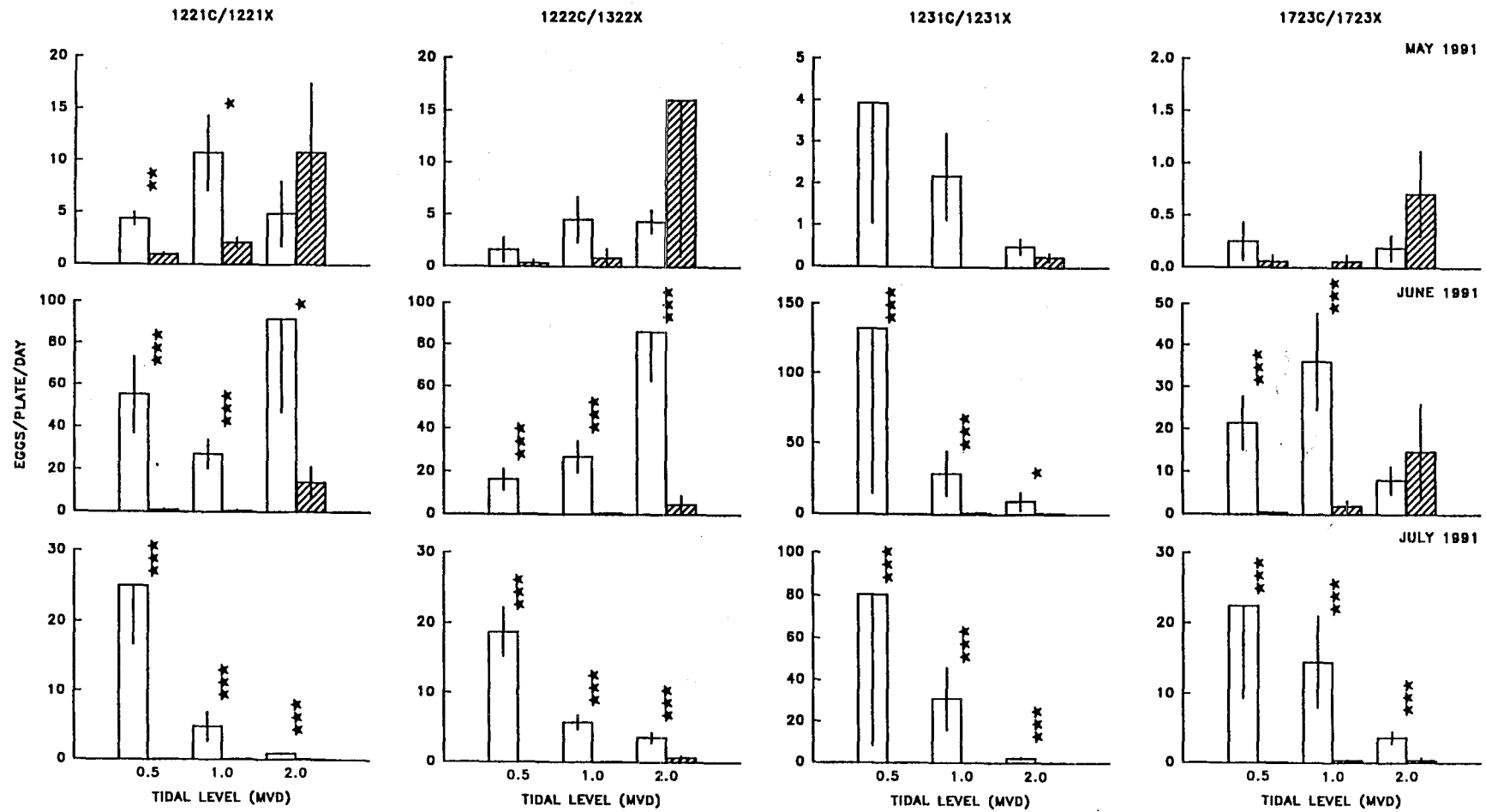

Figure 2.27. The average number of eggs caught per plate per day at four site pairs in the summer of 1991. Each column of graphs represents one site pair. Layout is the same as Figure 2.25.

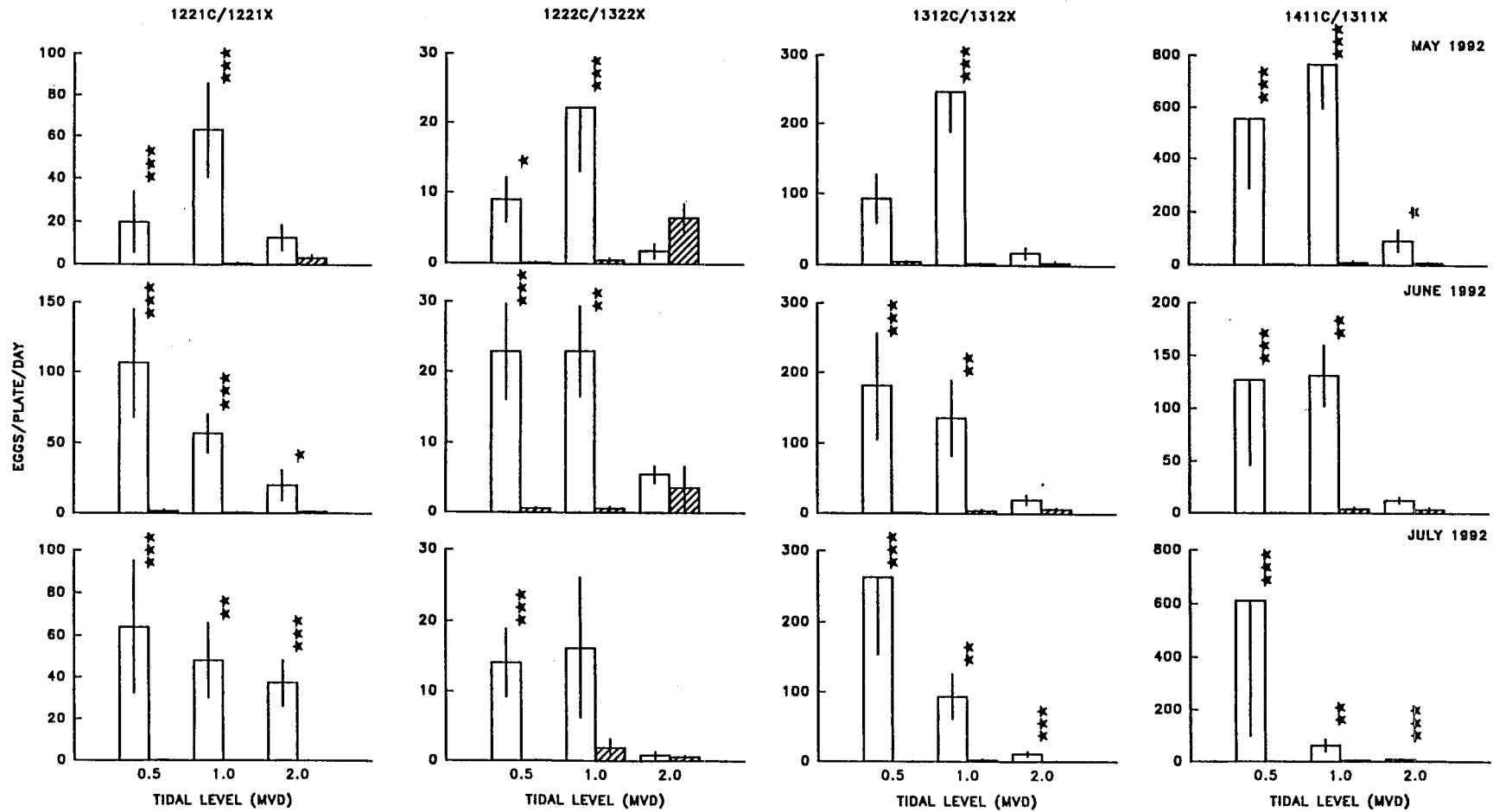

Figure 2.28. The average number of eggs caught per plate per day at four site pairs in the summer 1992. Each column of graphs represents one site pair. Layout is the same as Figure 2.25.

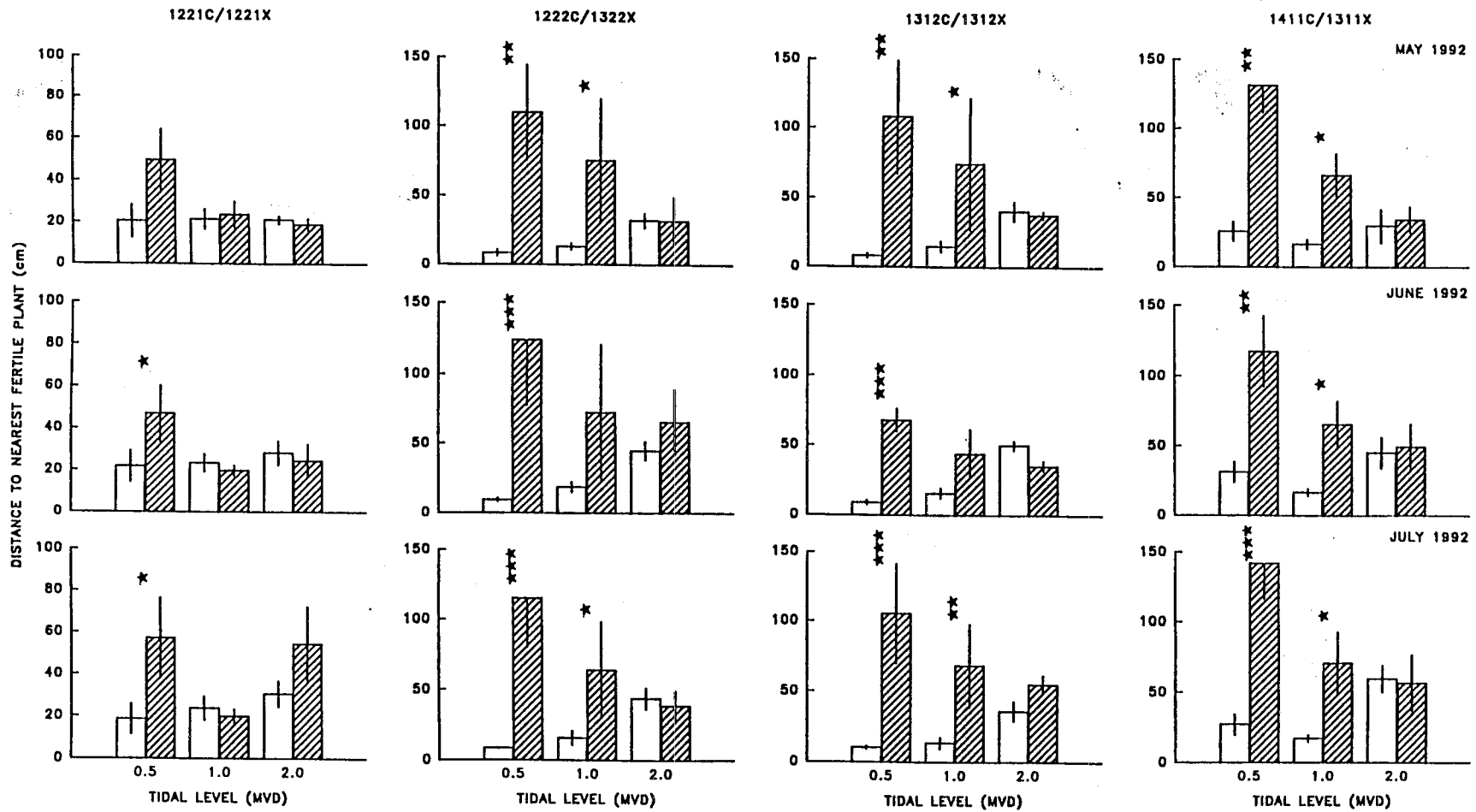

Figure 2.29. The distance to the nearest fertile *Fucus* plant from the egg catcher plates at four site pairs during sampling periods in 1992. Each column of graphs represents one site pair. Layout is the same as Figure 2.25.

Table 2.1. The dates of initial seeding, shipment to Herring Bay, and deployment in the field for the petri dishes (Petri1 and Petri2) and ceramic tiles (Tiles) used for the *Fucus* germling growth and survival studies.

<u>Plate set</u>	<u>Initial Seeding</u>	<u>Ship to Herring Bay</u>	<u>Deployment in Field</u>
Petri1	28 March 1991	2 May 1991	4 May 1991
Petri2	3 May 1991	30 May 1991	1 June 1991
Tiles1	30 May 1992	26 June 1992	4 July 1992
Tiles2	3 June 1992	26 June 1992	4 July 1992
Tiles3	6 June 1992	26 June 1992	4 July 1992
Tiles4	13 June 1992	26 June 1992	4 July 1992

Table 2.2. The mean and standard error (in parentheses) of the number of plants collected, wet weight of receptacles, number of eggs released, and percent of eggs viable for the *Fucus* reproductive potential and egg viability and the floating *Fucus* fertility studies. Asterisks indicate a statistical difference ($p < 0.05$) between oiled and control sites or attached and drift plants.

NUMBER OF PLANTS COLLECTED AT SHELTERED ROCKY SITES (N=3)				
		TIME 1	TIME 2	TIME 3
1 MVD	Control	8.0(2.0)	11.3(0.3)*	11.3(0.3)*
	Oiled	4.0(2.5)	2.7(0.7)	2.7(1.2)
2 MVD	Control	11.7(0.3)	11.7(0.3)	9.7(0.9)
	Oiled	5.7(2.9)	5.0(2.5)	3.7(1.7)
3 MVD	Control	9.3(0.3)	10.0(1.5)	6.7(0.7)*
	Oiled	8.0(1.5)	6.3(0.9)	3.0(1.2)
WET WEIGHT OF RECEPTACLE				
1 MVD	Control	0.34(0.06)	0.63(0.09)	0.83(0.09)
	Oiled	0.33(0.13)	0.70(0.20)	0.79(0.40)
2 MVD	Control	0.36(0.05)	0.99(0.11)	0.96(0.13)*
	Oiled	0.41(0.07)	0.61(0.17)	0.38(0.08)
3 MVD	Control	0.54(0.08)	1.02(0.14)*	1.02(0.17)
	Oiled	0.43(0.05)	0.59(0.08)	0.54(0.21)
Attached		0.43(0.04)*	0.88(0.07)*	0.92(0.07)*
Drift		0.83(0.13)	1.78(0.49)	1.49(0.16)
NUMBER OF EGGS RELEASED PER RECEPTACLE				
1 MVD	Control	1202.88(1182.11)	1292.24(1169.87)*	2761.82(1047.51)
	Oiled	36.6(25.34)	286.17(134.89)	331.09(256.28)
2 MVD	Control	235.02(134.82)*	2775.72(1239.04)	1178.16(775.85)
	Oiled	2494.44(1375.55)	703.66(570.41)	591.69(442.48)
3 MVD	Control	293.30(88.18)	380.67(121.52)	137.76(29.70)
	Oiled	1420(719.60)	892.48(272.33)	72.47(33.65)
Attached		520.77(329.91)	1540.46(598.15)	1576.19(516.27)
Drift		366.25(227.46)	791.72(505.90)	2728.99(1168.43)
PERCENT OF RELEASED EGGS WHICH ARE VIABLE				
1 MVD	Control	15.9(6.7)	42.9(8.5)	100.0(0.0)
	Oiled	10.6(8.3)	36.9(17.1)	100.0(0.0)
2 MVD	Control	18.1(6.3)*	51.3(7.7)*	100.0(0.0)
	Oiled	42.0(10.0)	22.6(9.9)	100.0(0.0)
3 MVD	Control	33.4(7.3)*	28.9(7.7)	100.0(0.0)
	Oiled	67.8(7.6)	21.4(6.1)	100.0(0.0)
Attached		22.4(4.0)	41.6(4.7)*	100.0(0.0)
Drift		33.4(7.3)	13.8(5.1)	38.1(7.3)

Table 2.3. The average desiccation rate of cotten balls (grams of water lost per hour) in the first MVD at oiled and control sites (N=12).

<u>OILING</u>	<u>MEAN</u>	<u>S.E.</u>	<u>F-Ratio</u>	<u>P-value</u>
Oiled	0.228	0.021	20.918	0.000
Control	0.103	0.026		

Table 2.4. The average density of *Fucus* germlings on petri dish plates subjected to whiplash from adult plants for two weeks and on plates without whiplash (Control). The starting densities for all plates were similar to the ending value for the control plates.

<u>Treatment</u>	<u>MEAN</u>	<u>S.E.</u>	<u>DF</u>	<u>T-Value</u>	<u>P-value</u>
Control	77.45	7.90	5	9.694	0.010
Whiplash	0.73	0.32			

Table 2.5. The mean and standard error (in parentheses) of the percent survival of seeded germlings and the number of new recruits on unseeded tiles at two tidal levels in the presence and absence of herbivores and on tiles with no cage. There were no statistical differences, but the data had unequal variances, violating the assumptions of the three-way ANOVA.

<u>PERCENT SURVIVAL OF GERMLINGS ON SEEDED TILES</u>					
		<u>+HERBS</u>	<u>-HERBS</u>	<u>NO CAGE</u>	
1 MVD	Control	218.60 (150.50)	30.70 (17.40)	15.59 (13.34)	
	Oiled	11.98 (9.62)	27.80 (15.63)	3.92 (3.91)	
2 MVD	Control	12.11 (9.69)	20.83 (2.12)	35.02 (20.82)	
	Oiled	3.17 (1.42)	13.65 (5.88)	13.34 (6.24)	
<u>RECRUITMENT OF NEW GERMLINGS ONTO UNSEEDED TILES</u>					
1 MVD	Control	502.55 (340.98)	687.67 (180.72)	1557.95 (216.66)	
	Oiled	495.57 (123.16)	819.36 (321.32)	1048.07 (141.44)	
2 MVD	Control	609.55 (205.08)	980.66 (380.17)	632.31 (366.69)	
	Oiled	1124.02 (243.62)	244.11 (84.13)	1053.72 (433.11)	

CHAPTER 3. INVERTEBRATE STUDIES

INTRODUCTION TO INTERTIDAL INVERTEBRATE STUDIES

Part of the intertidal monitoring and experimental study in Herring Bay was initiated to document the potential impact of *Exxon Valdez* oil on intertidal invertebrates. The study design involved the selection of oiled and control sites as outlined in Chapter 1. Sediment samples for hydrocarbon analysis were collected and analyzed as outlined below to document differences in hydrocarbon concentrations between control and experimental sites. In addition, experiments were designed to test the effects of oil on recruitment and survival of major invertebrate taxa at the various sites. A brief outline of the rationale for the various experiments is presented below. The experimental designation is given in parentheses.

Some oiled locations in Herring Bay had heavy accumulations of dried tar, especially in the upper intertidal zone, where desiccation and baking by sunlight created an asphalt-like condition. The asphalt material may affect recruitment by altering the settlement substrate. The effect of oiled substrates on settlement success was tested by coating control and experimental surfaces with oil and documenting differences in settlement at control and experimental sites (Oiled Rock/Tile Study). In addition, a study was initiated to determine the effects of a tar layer on settlement and post-settlement survival of barnacles (Barnacle Recruitment Study) by comparing recruitment on tarred areas to that on cleaned areas within the tarred substrate and untarred control sites.

In 1989 and 1990, the Coastal Habitat Study showed an increase in the abundance of mussels at oiled sites. The increases may have been due to preferential settlement on certain species of filamentous algae (Dayton, 1971; Suchanek, 1978; Peterson, 1984) which had evidently colonized oiled sites. Therefore, supplemental experiments on floating tiles were designed to examine the sequence of settlement in clean surfaces, not subjected to predation by intertidal echinoderms and mollusks (Settlement Patterns). In addition, mussel recruitment at oiled and control sites was monitored on quadrats with algae and quadrats cleared of algae and fenced to exclude predators (Mussel Recruitment).

Recruitment of species with planktonic dispersal stages into impacted areas was expected to occur more quickly than that of species with direct development. The periwinkle, *Littorina sitkana*, the dog whelk, *Nucella* spp., and the six-armed starfish, *Leptasterias hexactis*, were selected for abundance and recruitment studies because they do not have a swimming dispersal phase in their life histories, and would probably recover slowly if oil or shoreline treatment reduced their populations (Population Dynamics of Selected Invertebrates). Limpets, which do have a planktonic larval phase in their life history, were chosen for study because of their likely importance as grazers in the community. Potential differences in algal grazing by limpets, algal recolonization rates and limpet

survivorship on oiled and control sites were examined using fenced and caged enclosures (Grazing by Limpets). Since population monitoring of limpets in 1990 and 1991 indicated that *Tectura persona* populations were reduced more than *Lottia pelta* on oiled sites, a special study was initiated to determine if grazing intensity differed between the two taxa (*Tectura persona* and *Lottia pelta* Grazing Study).

The methods of each experiment are described in detail under the experiment designation.

INVERTEBRATE METHODS

Population Dynamics of Selected Invertebrates

Five site pairs were selected for population dynamics studies in 1990. Replication with site pair design was strengthened by adding one additional protected rocky site pair and one coarse-textured oiled beach in 1991, for comparison to an existing control site. Four additional protected rocky site pairs, originally established in 1990 for general site characterizations, were added to the list of sites for population dynamics studies in 1992, because their treatment history and orientation within Herring Bay made them good additions for long-term monitoring.

The permanent quadrats established for *Fucus* population studies (see Chapter 2) were also used to measure invertebrate densities. Nine quadrats were established on each site added in 1992. Within each permanent quadrat, all limpets, *Nucella* spp., *Littorina sitkana* and *Leptasterias hexactis* were counted. A 1.0 m radius semicircle centered on the left side of the quadrat was marked off, the distance to the nearest specimen of the above species within the semicircle was measured and recorded, and size measurements were made on these specimens. For limpets, shell length and width were recorded. For littorines and *Nucella*, length of the shell from apex to tip of siphonal canal was measured. For *Leptasterias hexactis*, the arm-tip to arm-tip diameter of each seastar was recorded. Examination of the quadrats continued through 1992.

Sediment Hydrocarbons

Sediment samples for hydrocarbon analyses were collected in 1990 and 1991 at seven oiled and control site pairs. Samples were collected from a 1 m radius to the left of study quadrats, using the EVOS SOP for sediment hydrocarbon sampling. The sediment samples were sent to NOAA's Auke Bay Laboratory for analyses. Sampling for sediment hydrocarbons was discontinued after 1991.

Barnacle and *Fucus* Recruitment

During 1990, barnacle recruitment studies were done at two oiled (1641A and 1342D) and two similar control sites (1641B and 1642C) (Fig. 1.1). All sites included vertical rock faces occupied by barnacles, however, only the remains of tests were present on portions of heavily oiled and treated sites. Barnacles occurring in high densities included *Balanus glandula* and/or *Semibalanus balanoides*.

A series of 10 X 10 cm paired study plots was positioned on the vertical rock face at each site as follows: the length of each site was measured, and the number of plots divided into the site length producing segments. A random number was used to determine the position of the first plot within the first segment, and subsequent plots were spaced equal distances apart along the site. One member of each pair was scraped and brushed to remove all visible tar (or barnacles in the case of control sites). A coin was flipped to determine which member of the first pair to scrape. The subsequent scraped plots were then alternated. The sites were periodically examined for settlement of barnacles and *Fucus* germlings. Each 100 cm² area was also photographed.

Two site pairs were added to the study in 1991: 1443C and 1343X; 1544C and 1544X. Two additional oiled sites, 1645X and 1746X, were matched with control site 1641B (Fig. 1.1B). The experiment was also modified by adding grazer exclusion cages, assigned at random, to half of the study plots. The cages were constructed of 4 mm mesh stainless steel hardware cloth, and were glued to the vertical rock surface using marine epoxy. The mesh size of the hardware cloth excludes most limpets and littorines, with the exception of juveniles less than 4mm width, which were removed by hand during each site visit.

Oiled Rock/Tile Study

In 1990, three pairs of oiled and control sites were selected for a recruitment study involving transplanting oiled substrates: sites 1221C and 1221X, 1222C and 1322X, 1723C and 1723X (Fig. 1.1a.). The substrates consisted of 72 rocks retrieved from an oiled shoreline in Herring Bay. These rocks represented a substrate coated with 1 year old *Exxon Valdez* Crude (EV). The rocks were separated with aluminum foil during transport to prevent contact with one another.

Eight of the rocks, selected for oil weathering analysis, were loosely covered and stored at ambient temperature. One-half of each of the remaining 64 rocks was thoroughly cleaned with methylene chloride (MeCl₂) to remove the oil and allowed to dry. That portion of each rock with the least irregularity was used as the sampling surface. The rocks were marked with a unique identification number, measured for total length, length of the cleaned and oiled sides, and

photographed. As a control for possible effects of MeCl_2 on recruitment, half of the "top" of six unoiled rocks was "cleaned" with the solvent (one rock per site).

An additional 72 rocks were collected from a similar, but unoiled, beach. Half of each rock was dipped in fresh Prudhoe Bay crude (PB) until a "tarred" coating was achieved, they were allowed to dry for several weeks and handled identically to the EV rocks.

Seventy-two white clay tiles were included in the experiment as a control on surface heterogeneity. Half were coated with fresh PB oil and the others were not treated. Oiled and clean tiles were placed side-by-side in the field as paired units. In early June, 1990, 12 EV rocks, 12 PB rocks and 6 tile pairs were placed randomly at 2 m below MHHW on each of the six experimental sites (Fig. 3.1A). An oiled rock to document oil weathering and a MeCl_2 control rock were also placed at each site. Barnacle and macroalgal populations on each surface type were recorded in the field at approximately two week intervals as follows: the edge of a 3 cm X 3 cm quadrat was placed at the midpoint of the line separating the oiled and unoiled portions of the rocks or at the upper right corner of the tiles. Individuals within the quadrat were counted, identified to species when possible, and the quadrat was photographed. On three occasions (mid-summer 1990, early fall 1990, and mid-spring 1991) two EV and PB rocks were removed and their populations assessed in the laboratory using dissecting microscopes.

Samples to document changes in the chemical composition and thickness of the oil coatings on the rocks and tiles were collected as follows: a 3 X 3 cm area on the "weathering" rocks oiled with EV and PB was sampled by MeCl_2 extraction using a pre-weighed absorbent material, which was then placed in a pre-weighed vial. Each vial was opened and stored at room temperature until dry, the absorbent material was then reweighed, the sample vials were then refilled with MeCl_2 , and refrigerated (approximately 4° C) for gas chromatography/flame ionization detection analysis (Brumley, *et al.* 1968).

Nine new, red clay tile pairs were added to each study site in 1991. Six of the pairs consisted of a tarred and a clean tile, half of which were enclosed by 4 mm mesh stainless steel cages to exclude grazers. The remaining three pairs consisted of a clean tile and a tile painted black (rather than oiled) as a control for dark coloration and possible temperature differences (Fig. 3.1b). All tiles were placed randomly at MVD2. In addition to the nine tile pairs, a single oiled tile was added to each site and periodically wiped with MeCl_2 solvent as described above to sample for weathering. Different corners were wiped on each sampling date to avoid resampling a previously wiped surface. All wipes were preserved and stored for analysis as described above.

Mussel Recruitment

Two pairs of oiled and control sites with mussel populations were selected for mussel recruitment studies: sites 1361C and 1361X; 1362C and 1362X (Fig. 1.1B). Six transects were randomly established at each site and four 25 X 25 cm plots were placed at 1.6 m below MHHW at 1 m intervals across each transect. Two plots on each transect were cleared of all algae; the remaining plots were marked with screws at the corners, but left uncleared. A 10 cm high fence of 4 mm mesh stainless steel hardware cloth was installed around the edge of each cleared plot. The densities of limpets and littorines were counted in the fenced and unfenced plots twice weekly, and grazers were removed from the fenced plots to allow filamentous algae to grow. Limpet and littorine densities were compared between sites and between treatments, to test for efficiency of the fences in excluding grazers. The sampling was done throughout the 1991 field season and in the spring of 1992.

Sampling of algae and juvenile mussels in the plots was done as follows: a grid of 625 1-cm squares was placed over each plot, ten squares were randomly selected and a 1 cm² "plug" of filamentous algae was extracted from each of the ten squares. Juvenile mussels were counted in three of the ten subsamples with a dissecting microscope and the coefficient of variance (CV) was calculated. If the CV was greater than 0.10, an additional sample was sorted and the CV recalculated until a CV of 0.10 was achieved or all ten samples processed.

Settlement Patterns

Five floating settlement sites were randomly selected from the lower half of Herring Bay using segment maps at a scale of 1:24,000. The sites correspond to segments 5012, 122, 145, 125 and 133. The center of each segment was located in the field, the main habitat was identified and three transect heads were randomly selected along the length of the main habitat type. Settlement stations were anchored off the head of each transect in water of 8-10 m depth at high tide, and settlement plates were suspended 1 m below the surface. Each settlement station held 12 tiles made from marine epoxy and a preweighed Plaster-of-Paris hemisphere to estimate relative current speeds at the various stations. The hemispheres were removed, weighed and replaced several times during the season. One tile was removed every week for twelve weeks and examined under a dissecting scope for settlement.

Grazing By Limpets

Three studies were designed to examine differences in algal grazing by limpets between oiled and non-oiled sites, algal recolonization rates, and survivorship of limpets. Four pairs of oiled/control sites with heavy *Fucus* cover were selected for the first study and eight 25 X 25 cm fences, consisting of 4 mm mesh stainless steel hardware cloth, were installed with marine epoxy at two

elevations (contours in the figures and tables), making a total of 16 enclosures per site (Fig. 3.2). The upper experimental elevation, located 1 m below the upper edge of the *Fucus* zone (about 1 MVD), was selected at the control sites first, because treatment by Exxon caused extensive loss of *Fucus* in the upper zones at oiled sites (Houghton *et al.* 1991). The upper experimental elevation at oiled sites was located at the same MVD as the corresponding control site and verified by evidence of *Fucus* holdfast remains, consisting of basal discs or "skeletonized" stipes on the rocks. The lower experimental elevation was located in an algal zone dominated by a species other than *Fucus* (i.e. *Cladophora*) (2-2.5 MVD). During cleanup operations Exxon treated shorelines only to the mid-intertidal, above the "green zone" (ADEC unpublished shoreline assessment forms, 1989). Therefore, the lower experimental elevation was located on oiled sites at the top of the green zone, where impacts from treatment activities were observed, and the lower experimental elevation at control sites was located at the same MVD as that on the corresponding oiled site.

Placement of the first fence at each elevation was determined randomly, and subsequent fences were evenly spaced throughout the workable length of the site. A small band outside of the 625 cm² area was scrubbed clean so the marine epoxy would adhere to the substrate, and the fences were attached and allowed to stabilize for approximately two weeks prior to beginning the experiment. Small inward-pointing lips were attached to the fences and large *Fucus gardneri* plants inside and outside the fences were trimmed back to prevent the limpets from entering or escaping.

Three sampling transects were randomly established to determine the average limpet densities at different MVDs on ten different sites in Herring Bay. The methods were identical to those employed for the population dynamics study, mean limpet density in a 625 cm² area was estimated and used to determine stocking densities in the limpet fences.

Limpets, 10-15 mm in length, were collected from locations well away from the study sites and tagged using ID numbers written in indelible ink on plasticized paper attached to the shell with fingernail polish. They were then weighed, measured (shell length), and sorted by size and species into groups approximately equal to the previously determined mean number per 625 cm² (X). All algae inside half of the fences was removed, sorted into filamentous and *Fucus* categories, and wet and dry weights were measured. The limpet groups were held for up to two days and randomly placed at different densities inside the fences according to treatment. Treatment densities were half, twice and equal to the mean (X/2, 2X and X respectively) (Fig. 3.2). Limpet populations and algal cover inside the enclosures were monitored weekly. Percent cover of algae within each enclosure was determined using a random point method. Percent cover of *Fucus gardneri* was recorded separately from other macroalgal species because it dominates the canopy but not the primary substrate in most cases. At the end of

the experiment all surviving limpets were retrieved and any remaining algae was collected for wet and dry weights.

A second experiment was set up using cages (fences with tops) to better retain limpets and exclude predators. Three sheltered rocky site pairs were selected and eight cages per site were randomly placed in algal beds at 2 MVD as outlined above. Five hundred and four 10-15 mm long limpets of identical species composition to those found at the second MVD were collected, sorted and distributed into cages as described above for the fence experiments, with the exception that tagging which was done with 5 mm long plastic tags glued to the shells with orthodontic cement. The cages were examined immediately after the first tidal cycle, and all dead limpets were replaced with freshly tagged specimens. Limpet and algal abundance in the cages was subsequently monitored weekly as described above for the fencing study. Limpet fencing and caging experiments were discontinued in 1991 due to high limpet mortality.

An alternative series of experiments was set up in 1991 to examine limpet survivorship and growth between oiled and control sites with and without *Fucus* canopy. Six EVOS shoreline segments on oiled and control sites in the northern half of Herring Bay were randomly selected and paired as closely as possible by physical characteristics and orientation. The main habitat type along each of the segments was identified and measured at approximately MHHW. The ends of each site were permanently marked with stainless steel screws. Eight positions were randomly selected along each site length and permanent screws with tags were anchored to the substrate at 1.5 MVD below each position. Ten limpets greater than about 8 mm length occurring within a 1-m diameter circle of each screw were measured (length and width), and marked with small plastic tags attached to the shell with super glue gel. The position of each tagged limpet relative to the center marker was recorded. The first plot on each site was randomly selected as a control or treatment plot and all *Fucus* within 1 m of the center tag were then removed from alternate plots along each site by cutting off the plants at the base of the stipe. After approximately one year, the remaining tagged limpets were collected, weighed and the shell length and width measured.

***Tectura persona* and *Lottia pelta* Grazing Study**

This experiment was designed to detect differences in grazing intensity and vulnerability to oil by *Lottia pelta* and *Tectura persona*.

Sixteen cages were constructed with 500 cm² Plexiglas plates for the floors, 10 cm high walls of 4mm mesh stainless steel hardware cloth and a cover. A grid of one hundred squares was etched into each Plexiglas plate to standardize estimates of percent algal cover. Eight of the sixteen plates were oiled with North Slope crude and allowed to weather for approximately 10 days, thus producing a tar-like coating. The cages were randomly anchored at 1 MVD on a site

supporting both *Lottia pelta* and *Tectura persona*, and allowed to foul for about three weeks.

Lottia pelta and *Tectura persona* were then collected from the site, weighed, measured, and marked using plastic tags attached to the shells with super glue gel. Based on previous density estimates, seven specimens of each taxon were randomly placed in each oiled or unoiled cage, depending on the species, thus producing four oiled and four unoiled treatments for each species. The percent algal cover and limpet survivorship in each cage were monitored during the 1992 field season. The surviving limpets were reweighed, remeasured and returned to the cages at the end of the season; limpets which had died during the summer were replaced so the experiment could be continued in 1993.

INVERTEBRATE RESULTS

Population Dynamics of Selected Invertebrates

The 1992 quadrat data for each site pair on each sample date were analyzed according to the statistical procedures outlined in Chapter 2. The means, standard errors and significance levels for all sites are presented in Figures 3.3-3.47. Species with low frequency (i.e., *Nucella* spp., *Leptasterias hexactis* and *Tectura scutum*) were analyzed using a randomization test (Manly 1991). A repeated measures analysis of variance was used to compare sites over the three year period. Because only two dates were sampled during the 1992 season, two similar dates from 1991 and 1990 were selected for use in the summary analyses. These results were used in conjunction with the t-test results to gain an understanding of temporal changes.

In general, *Tectura persona* densities have remained significantly higher at control sites during the three-year study period, especially at MVD 1 (Table 3.1; Fig. 3.3-3.7). *T. persona* is common in the mid- and upper-intertidal zones in sheltered rocky and coarse textured habitats but less abundant at MVD 3, except in coarse-textured habitats where it is reasonably common (e.g., site pairs 2333, 2834, and 2337). Similar trends were observed at the four site pairs added in 1992 (1221, 1222, 1411, 1713) (Fig. 3.10-3.13). *T. persona* densities were significantly lower ($p \leq 0.04$) in MVD 1 on both sampling dates at two of the oiled sites (1411 and 1713); differences were non-significant ($p < 0.17$) but perhaps suggestive at the remaining site pairs.

Lottia pelta is distributed lower in the intertidal than *T. persona* and is usually most abundant in MVD 2 and 3 (Table 3.1; Fig. 3.14-3.20). It may have suffered less impact than *T. persona*, since consistent differences in abundance on control and oiled beaches were lacking, with abundances occasionally significantly higher on oiled beaches as well as control beaches (Fig. 3.14-3.24). *L. pelta* abundances at the four site pairs established in 1992 (Fig. 3.21-3.24) were

generally greater at control than oiled sites, but only significant in one case (Fig. 3.21).

A third limpet species, *Tectura scutum*, was rare in the first MVD but present in mid- and lower-intertidal zones (Fig. 3.25-3.35). However, its density was much lower than that of *T. persona* and *L. pelta* and no significant differences in the abundance of *T. scutum* were observed between any of the site pairs.

The periwinkle *Littorina sitkana* showed a variable response to EVOS. Densities tended to be lower at MVD 1 and/or MVD 2 at three of the five site pairs sampled in 1990 (Figs. 3.36-3.40) but consistent patterns were absent in 1991 and 1992 (Table 3.2; Fig. 3.36-3.46). Substantial impact on *L. sitkana* from EVOS could not be consistently detected after 1990.

The dog whelk, *Nucella lamellosa*, was present in sufficient densities for statistical comparison at one (1732) of the seven site pairs (Fig. 3.47). There were no statistically significant differences in densities between sites. The other direct developers, *Nucella lima* and *Leptasterias hexactis*, were either absent or not abundant enough for meaningful statistical analyses.

Sediment Hydrocarbons

Hydrocarbon data for 1990 and 1991 were provided by NOAA for most sites (Table 3.3). Samples were not collected at some sites on some sample dates because sediment was scarce within the rocky substrate. For each site, samples collected within each MVD were pooled for analyses. The hydrocarbon analyses employed HPLC coupled with UV Fluorescence (Krahn et al. 1991), which produces only semi-quantitative results (compared to GC/MS). However, relative ranking of sediment hydrocarbons was possible, using an index calculated by subtracting the integrated peak measured at phenanthrene wavelengths from the integrated peak measured at naphthalene wavelengths (C. Manen, personal communication). The hydrocarbon concentrations were significantly higher at oiled sites in both years ($p < 0.002$, Mann-Whitney U-test for pooled control versus oiled sites, Table 3.4) and tended to be highest in the upper intertidal zone. The indices decreased by 40-60% at oiled sites from 1990 to 1991, suggesting hydrocarbon concentrations were decreasing over time.

Barnacle and *Fucus* Recruitment

Recruitment data were analyzed using a paired t-test between plots within each site (Fig. 3.48-3.58; 3.62-3.65; 3.67-3.70; 3.72-3.82). Analysis of variance was used to compare like treatments between oiled and control sites as well as the effects of caging (Fig. 3.59-3.61; 3.66, 3.71, 3.83-3.85).

There was a pattern of significantly higher barnacle recruitment on scraped plots at control site 1641B in 1990 and on caged scraped plots at oiled site 1645X

in 1991 (Figs. 3.48, 3.57). Recruitment was also higher on unscraped caged plots at site 1642B in 1991 (Figs. 3.54, 3.57). No consistent patterns of significant differences were observed at the other sites and treatments (Fig. 3.48 - 3.58). Barnacle recruit densities were significantly higher on scraped plots at control sites compared to oiled sites until late June, 1990 ($p \leq 0.05$, ANOVA; Fig. 3.59). Barnacle recruit densities were significantly higher on unscraped control plots compared to unscraped oiled plots for a brief period in mid-season, 1990 (Fig. 3.59). The density of barnacle recruits was significantly greater on uncaged unscraped and scraped plots at oiled sites on 4 and 5 of 10 sample dates, respectively, ($p \leq 0.047$, ANOVA; Fig. 3.60). Barnacle densities were significantly greater on caged scraped and unscraped plots at the oiled sites for a number of sample dates, especially in scraped plots ($0.0007 \leq p \leq 0.05$, ANOVA). Density differences between caged and uncaged scraped plots were significant on two dates during a settlement pulse from late-June to early-July ($p \leq 0.04$, ANOVA), and were not significant at any other time.

In 1992, recruitment was variable between scraped and unscraped plots, with no overall trend exhibited (Fig. 3.48-3.58). However, in May, densities of recruits were significantly greater at the control sites for all treatments (i.e. scraped, unscraped, caged and uncaged) compared to the oiled sites ($p \leq 0.05$, ANOVA; Fig. 3.61). Later in the season, this trend reversed in favor of the oiled sites. Overall densities were much lower in 1992 than in previous years.

Semibalanus, *Balanus*, and *Chthamalus dalli* adults in scraped and unscraped plots were counted in 1992 (Fig. 3.62-3.65). Adult barnacles are individuals that successfully recruited into the plots sometime during the course of the study and survived to 1992. There was a consistent pattern of higher average abundance of adult barnacles on unscraped as opposed to scraped plots at control sites because individuals alive before the spill were still present. Average densities of adult barnacles were consistently higher on uncaged, unscraped plots at two oiled sites (1342D and 1746X, Figs. 3.62, 3.63), where many of the 1991 recruits apparently survived to 1992. Oiled sites had significantly greater adult densities on all four sample dates on uncaged, unscraped plots ($0.009 \leq p \leq 0.04$, ANOVA), and three of four sample dates on uncaged, scraped plots ($0.004 \leq p \leq 0.01$; Fig. 3.66). No significant differences were observed between average adult barnacle abundances on the caged, unscraped plots at oiled and control sites. Caged, scraped plots had significantly greater adult densities at the oiled sites on all sample dates ($0.001 \leq p \leq 0.01$, ANOVA). Adult densities on scraped plots were significantly higher in cages on three of the four sample dates, and were significantly greater on unscraped plots by the end of the 1992 season ($0.001 \leq p \leq 0.04$; Fig. 3.66).

The densities of adult *Chthamalus dalli* tended to be higher, and in a few cases were significantly higher, in most scraped, caged and uncaged plots at oiled sites (Fig. 3.67-3.70). *C. dalli* was significantly more abundant on uncaged plots at oiled sites on all sample dates ($p \leq 0.01$, ANOVA; Fig. 3.71).

Fucus germling densities were consistently higher at all control sites for all treatments in all three years (Fig. 3.72-3.82). In 1990, unscraped plots at control sites had significantly greater densities of *Fucus* germlings compared to oiled sites on 20 of the 32 sample dates ($p \leq 0.05$, ANOVA; Fig. 3.83). *Fucus* germling densities on scraped plots were significantly greater at the control sites on 11 of the 33 sample dates ($p \leq 0.05$, ANOVA), however, germling densities were lower in scraped plots than unscraped plots at control sites suggesting the importance of microhabitat features in *Fucus* recruitment.

In 1991 *Fucus* germling densities remained higher in the control plots, and most were significantly greater from mid-July through August ($p \leq 0.01$, ANOVA; Fig. 3.84). The only apparent difference between caged and uncaged treatments was observed on the last sampling date, when germling density was significantly greater in caged than uncaged, unscraped plots.

Fucus germling densities in 1992 were greater at control than oiled sites, especially in caged plots (Fig. 3.85; $p < 0.006$). The scraped, uncaged treatments had significantly higher densities at control sites on two of the four sample dates ($p \leq 0.05$; Fig. 3.85).

Densities of grazers (limpets, *Littorina sitkana*, and *L. scutulata*) tended to be significantly higher at control than oiled sites in 1991 ($p < 0.05$, ANOVA; Fig. 3.86 and 3.87). Grazers were not sampled in 1992.

Oiled Rock/Tile Study

Comparisons were made using a paired t-test between oiled and unoiled halves of rocks and oiled and unoiled tile pairs. Settlement was not analyzed between sites, as only two oiled sites were consistently colonized over the three-year period (Sites 1322X & 1723X).

The rocks deployed in 1990 were weathered and dislodged from the substrate during the winter of 1990-91. The oil was completely weathered from the surface of many of the rocks; others could not be located and sampled in 1991. During 1990, the oiled halves of EV and PB rocks had consistently fewer barnacle recruits but differences were only significant on a few dates (Fig. 3.88). In general, there was little recruitment late in the season. There were no significant differences in the number of barnacle recruits on the surface of control rocks cleaned with methylene chloride and oiled surfaces on the same rocks ($0.35 < p < 0.9$) for nine sample dates (data not shown). No *Fucus* germlings were recorded on any rocks in 1990.

There was sparse settlement on the tile pairs placed at control sites in 1991 (Table 3.5). There were few differences in barnacle recruits, *Fucus* germlings or percent algal cover and no apparent trends. Sites 1322X and 1723X, which had

good recruitment in 1990, also had substantial recruitment activity in 1991. Although there tended to be higher numbers of recruits on unoiled tiles and the highest numbers of recruits occurred on uncaged tiles, there were few significant differences due to high variability. The clean and painted tile pairs had similar levels of barnacle and *Fucus* recruitment. Filamentous algae did not begin to colonize on the 1991 tiles until late September.

Barnacle recruitment in 1992 was substantially lower than in 1991 and patterns were not evident (Table 3.6). Low numbers of large barnacles on the tiles (Table 3.7.) indicate very few recruits reach adult sizes. *Chthamalus dalli* (Table 3.8) tended to recruit better on oiled tiles in caged treatments and on unoiled tiles in uncaged treatments at sites 1322X and 1723X, though differences were usually not significant. *C. dalli* densities were not significantly different on painted and unpainted tiles.

In 1991, *Fucus* did not recruit on uncaged or painted tile pairs and only began to recruit on caged, clean tiles at the end of the season (Table 3.9). Again, in 1992 there was almost no *Fucus* recruitment on uncaged or painted tile pairs (Table 3.10). Recruitment tended to be higher in the caged treatment on clean tiles and, except for site pair 1222C/1322X, there was a slight tendency for higher recruitment at control sites.

Percent algal cover on white clay tiles placed in the field in 1990 was significantly higher in 1992 on the non-oiled tile in only two of the 46 tests (sites 1322X and 1221X; Table 3.11). For red clay tiles deployed in 1991, differences within sites were not significant (Table 3.11) although cover was consistently high on uncaged tiles. Percent cover was somewhat greater on clean than painted tiles, but the differences were also not significant. In contrast to *Fucus* germling density, percent filamentous algal cover was significantly higher on uncaged, clean tiles than caged clean tiles during the last two sample dates of 1992 ($p < 0.05$, ANOVA; Fig. 3.89).

Methylene chloride wipe samples taken in 1990 and 1991 for oil weathering analyses were submitted to NOAA's Auke Bay laboratory. These samples were scheduled for a lower analytical priority relative to the sediment hydrocarbon samples, and have not been analyzed to date due to budgetary decisions by the Trustee Council (C. Manen, personal communication).

Mussel Recruitment

No samples were taken in 1991 because algal recruitment did not occur within the fences. The experiment was left in place over the winter and sampled in the spring of 1992. The fences at two control sites and one oiled site were destroyed and samples could not be collected. Algal plugs were collected from quadrats at one oiled site and sorted for mussel density. Samples yielded no mussel recruits (data not shown).

Comparison of grazer densities between fenced and unfenced plots revealed that with monitoring and removal, the fences were effective in excluding both limpets and littorines on the majority of sites and sample dates (Table 3.12A). Grazer densities were higher at control sites in the unfenced plots (1361C, 1362C) but statistical significance was generally only detected at the 1361 site pair (Table 3.12B). Site 1362X was lightly oiled and untreated in 1989, whereas site 1361X is part of a segment where an Omni Boom was used.

Settlement Patterns

Epoxy tiles were sampled from each floating station over eleven sample periods in 1991. Barnacle recruits were in very low densities at all five sites (Table 3.13). The tiles tended to become dominated by the hydroid, *Obelia* sp. (not quantified), by late July. High numbers of juvenile mussels did recruit, however, starting in mid-July. The byssal threads of the mussels were attached to the stalks of the hydroid colonies. Up to 100 juvenile mussels were counted per tile; densities above 100 were reported as ≥ 100 . Mussel densities steadily increased on each tile through the remaining sample dates (Table 3.13).

Plaster-of-paris dissolution hemispheres were placed on the stations on three separate dates (19 May, 17 July, and 3 August). The hemispheres were left for approximately 120 hours. The first two sample dates showed no significant difference in dissolution rate between eastern and western sides of the Bay. However, on the third date, the difference in hemisphere weight from the eastern sites was significantly greater than the western sites ($p < 0.001$, ANOVA; Table 3.13).

Grazing By Limpets

Only 106 of the 1072 limpets deployed in the fenced treatments were recovered at the end of the study (Table 3.14). Losses were very high at both elevations. Fifty-seven limpets remained at control sites, and 49 were found at oiled sites. Losses were much lower in the caging experiment (Table 3.14), in which 377 of 504 (75%) limpets were recovered at the end of the study (September, 1990). Losses were similar on control and oiled sites for both fenced and caged treatments.

Because of the random allocation of "algae" and "no algae" treatments at each site, percent algal cover was highly variable between sites and replicates for the treatments. To compare change between treatments, the mean difference in percent algal cover between the beginning and end of the experiment was calculated and compared between control and oiled sites using analysis of variance (Table 3.14). Percent reduction for "Algae" treatments were also averaged and compared for each elevation. Only treatment AX/2 from the cage study showed a significantly greater reduction in percent cover by algae at the oiled sites ($p=0.02$).

Because the percentages are calculated on different initial coverages, this result must be interpreted cautiously.

Differences in limpet pre- and post-experimental length, width and weight were analyzed for each treatment using t-tests (Tables 3.15 and 3.16). Differences in limpet length, width and weight for treatment AX in the fences (Table 3.15) tended to be greater at the oiled sites than the control sites and significantly so in 3 of the 6 comparisons. Of the limpets retrieved at the end of the experiment, no single density treatment was consistently greater in all parameters (length, width and weight). However, limpets in the caged plots at control sites had significantly greater differences in weights and widths (weight: $p=0.025$; width: $p=0.02$, t-Test), and treatment AX had significantly greater weights ($p<0.001$) compared to the oiled sites. Treatments A2X and AX/2 had significantly greater differences in shell lengths (A2X: $p=0.0001$; AX/2: $p=0.006$, t-test) and widths (A2X: $p=0.04$; AX/2: $p=0.05$) at the oiled sites compared to the controls (Table 3.16).

For treatments in which algal cover was removed (both fenced and caged), *Fucus* dry weight was significantly greater at control than oiled sites (Table 3.17). There was no difference in filamentous algal dry weight. At the end of the experiments, *Fucus* dry weight remained significantly greater at the control than the oiled sites and, as at the beginning, there was no difference in filamentous algal dry weights.

The post-experimental algal dry weight analysis for the caged study was divided into treatments with and without algae. *Fucus* dry weight remained significantly greater at control sites in those cages with algae retained ($p=0.01$). *Fucus* did not recruit into the cleared cages. There were no differences in filamentous algal dry weights at control and oiled sites for either algal treatment.

Only 5% of all limpets originally tagged and left for a year at plots with and without *Fucus* removal were retrieved in 1992. Return was so low that differences between cleared and uncleared plots within sites could not be compared. However, between sites there were no significant differences in recovery of limpets between cleared or uncleared plots ($p=0.68$, two sample sign test, Table 3.18). No significant differences were found in the initial length and width of limpets on oiled and control sites ($p = 0.37$ for length, $p = 0.62$ for width; Fig. 3.90). The percent change in limpet length and width between the oiled and control halves of the bay was significantly greater at oiled sites than control sites ($p = 0.001$ for length, $p = 0.004$ for width, ANOVA, Fig. 3.90).

***Tectura persona* and *Lottia pelta* Grazing Study**

Filamentous algae did not colonize the plexiglas plates during the 1992 season; therefore, percent algal cover could not be determined. The number of dead limpets in control and oiled cages and differences in mortality between *Tectura persona* and *Lottia pelta* were compared. Approximately 58% greater

mortality occurred in the oiled treatments, but this difference was not significant (Table 3.19). Mortality of the two species was similar. As stated in the methods, replacement limpets were measured and added to the cages so the experiment was continued through the winter/spring of 1992/93.

INVERTEBRATE DISCUSSION

Studies of previous oil spills have reported reductions in densities of invertebrates, particularly intertidal grazers such as limpets and periwinkles (Nelson-Smith 1977; Mann and Clark 1978; Southward and Southward 1978). The data presented here are consistent with these earlier studies. Effects of the EVOS on the invertebrates in Herring Bay have been variable, but there are patterns in the data demonstrating that some populations have been reduced and recovery remains incomplete in some cases. Results from the algal studies presented in Chapter 2, the hydrocarbon data, and population dynamics continue to point to the upper intertidal as the most extensively affected zone.

Recruitment, including that of algal cover, appears to play the major role in structuring invertebrate communities at the Herring Bay study sites. The sites showing the most consistent and/or highest invertebrate recruitment are hypothesized to be those most exposed to open water or tidal currents, which would increase larval availability at those sites. Not surprisingly, these were also the sites hit by the floating oil. Data on water motion near study sites is being developed in 1993. From the barnacle and oiled rock/tile recruitment studies, annual settlement patterns correspond well with locations of the most heavily oiled sites. For unknown reasons, barnacle recruitment was much lower in 1992 than in previous years. It is of interest to note, however, that there were two heavy recruitment periods at similar times (early July, early August) in both 1990 and 1991 (Fig. 3.48-3.58). In 1991, the floating settlement plates also showed large increases in *Mytilus* recruits during the same time as the barnacles (e.g. Fig. 3.60; Table 3.13). Had Herring Bay received recruitment during the same periods in 1989, this would have been when shoreline treatment was at its most intense (July-August, ADEC Daily shoreline assessment forms).

Densities of *Tectura persona* tended to be higher at control sites than oiled sites in the first and second MVD through both 1991 and 1992 (Fig. 3.4-3.14), suggesting continued effects of the oiling or treatment. Trends in the density of *Lottia pelta*, which occurs somewhat lower in the intertidal zone than *T. persona*, are less clear (Fig. 3.5-3.24), although densities were significantly greater at control sites in several comparisons and only greater at oiled sites twice.

The loss of *Fucus* plants from the upper intertidal (e.g., Fig. 2.3, 2.7) could be responsible for lower limpet recruitment/survival there, although the results of the limpet studies do not support this hypothesis. Further study of the potential role of *Fucus* in determining invertebrate density is being conducted in 1993.

Grazer densities were reduced at untreated oiled sites in the barnacle study (Fig. 3.86, 3.87) and the population dynamics study (Table 3.1). Densities of the invertebrates in both studies, with the exception of *T. persona*, showed population increases over the three year period.

One focus of the population studies was the hypothesis that invertebrates lacking dispersal phases in their life histories, such as *Littorina sitkana*, *Nucella* spp. and *Leptasterias*, would take longer to recover on oiled or oiled and treated sites because of reduced adult densities and/or fecundities at these sites and the low probability of recruitment from elsewhere. Of the three species studied, only *L. sitkana* showed possible effects of oil. In 1990, *L. sitkana* densities on oiled sites were significantly lower on coarse-textured habitats only, but in subsequent seasons reductions in abundance similar to those observed in limpets occurred at MVD 1 and 2 on oiled sites (Table 3.2). Low densities of the predatory invertebrates *Nucella* spp. and *Leptasterias* were observed at both control and oiled sites, thus complicating population assessment by us and others (Houghton et al. 1990). There were no differences in density between the oiled and control sites at the one site pair where large numbers of *Nucella lamellosa* were observed. The snails may have migrated to the lower intertidal or subtidal during the winter months and not been active until later in the summer of 1989, thus avoiding the worst conditions following the spill. Moreover, observations at the *Nucella* site suggest that it was not treated (Table 1.1). Ebert et al. (1992) found that survival and growth of *Nucella lamellosa* was lower at oiled than control sites (including an oiled site in Herring Bay).

The recruitment studies on oiled and non-oiled surfaces have shown that oil had an initial effect on barnacle recruitment, and depending upon substrate character, may have a moderate to long term effect on algal recruitment. A separate EVOS study of oiled rocks and algal recruitment has documented a similar suppression of algal colonization (Duncan et al. 1992). Residual tar may be an unstable substrate for barnacle settlement and reduced densities on oiled sites may be a consequence of tar sloughing rather than toxicity, as evidenced by the low percentage of recruits surviving to adult size (Table 3.7). *Fucus* settlement and growth, and algal cover were consistently lower on oiled tiles over two seasons (Tables 3.9-3.11), however, the differences were usually insignificant ($0.1 \leq p \leq 0.25$), probably due to high variability relative to the numbers of replicates. Caged tile pairs had significantly greater numbers of *Fucus* germlings than uncaged tiles (Table 3.10). In contrast, percent algal cover was much higher on uncaged tiles (Table 3.11, Fig. 3.89). Evidently, the cages provide an environment favoring *Fucus* recruitment and/or survival or an unfavorable environment for other algal species that may compete with *Fucus* on uncaged tiles. Alternative explanations include selective grazing on *Fucus* on uncaged tiles and poor recruitment and survival by other algal species inside cages. It seems unlikely that limpets, the predominant grazers, would be able to distinguish between germlings and sporlings of different algal species when rasping the substrate. Therefore, microhabitat differences seem the most likely explanation. *Fucus*

germlings also occurred in higher densities in caged plots in the tarred rock experiment (Fig. 3.85). Perhaps cages provide enough shading to reduce desiccation of the germlings or may snare the mucous strands in which *Fucus* eggs are released by the parent plant.

Significant differences in *Fucus* densities and algal cover on the tarred and untarred surfaces of rocks set out in 1990 and sampled in 1991 were not observed, possibly due to loss of too many replicates during the winter. Although care was taken in matching rock sizes, the parent material (including the degree of porosity for each rock) varied, especially with the PB rocks. Many rocks were dense and non-porous and the oil quickly dissipated to the extent that comparisons between oiled and non-oiled halves could no longer be made. The tile pairs were much less variable. Tiles placed in the field in 1990 were of a siliceous clay and may have retained north slope crude more effectively than the red clay tiles used in 1991. Nonetheless, all tiles have retained a degree of oil staining not found on many of the rocks. Within Herring Bay, rock substrate differs from site to site and several of the study sites have a more porous substrate than others. Sites 1723X and 1322X are areas where a porous pillow basalt has been found to retain fresh oil in many of the fissures (personal observation).

A widely held hypothesis regarding the EVOS has been that the elimination of grazers resulted in increased abundances of ephemeral algae. Significantly greater percent cover by ephemeral algae at oiled sites has been documented in Prince William Sound (Highsmith *et al.* 1993) and at some sites in Herring Bay (Fig. 2.12, 2.14). Inspection of the limpet fencing data (Table 3.14) indicate that responses based on different limpet densities are largely unpredictable. So many limpets disappeared from the fenced enclosures that it would not be prudent to contend that limpets controlled algal cover in this case. Limpet losses were lower in caged treatments and percent cover is not correlated with limpet density. Further work is needed to gain a better understanding of the impact of grazers on intertidal algae relative other factors that may control algal abundance.

Fucus dry weights were significantly lower at oiled sites than control sites at the beginning and end of the caging and fencing experiments while analogous comparisons on filamentous algae revealed no differences (Table 3.17). The above comparisons again suggest that ephemerals are more tolerant or successful in oiled sites than the dominant alga.

The limpet growth study with *Fucus* canopy retained and removed, ran for a full year. The presence of *Fucus* canopy did not result in a higher percent recovery of limpets (Table 3.15). However, at many of the cleared plots *Fucus* had regrown from cut stipes as described by McCook and Chapman (1992; personal observation). Growth by some of the recaptured limpets was quite evident. Oiled sites had the greatest percent increase in limpet length and width (Fig. 3.90), in seeming agreement with the weak trend of greater limpet growth at oiled than at control sites in the fencing and caging studies.

In summary, since the beginning of the Herring Bay study in 1990, the upper and mid-intertidal zones continue to show reduced densities of some invertebrates at oiled sites. Recovery of these zones may be dependent upon regrowth of *Fucus* to provide structural habitat. Recruitment is consistently greater in certain areas of Herring Bay. Many of these locations are sites where oil was grounded, suggesting that the oil was transported by currents that commonly carry larvae into sections of the bay. Oil initially reduced barnacle recruitment but this effect has not persisted. However, oil may have long-lasting effects on algal settlement, depending upon retention of oil by the substratum. While oil apparently reduced the densities of some limpets, in particular *Tectura persona*, manipulation of varying limpet densities failed to measure a consistent response in percent algal cover or limpet growth rates.

Based on the physical differences outlined in the introduction, which are supported by differences in recruitment intensity, the control sites may be conservative comparisons for the more exposed oiled sites. Given that the recruitment data show greater settlement at the more exposed sites, it is likely that pre-spill populations were originally higher at the oiled sites compared to the controls. Consequently, utilizing a statistical significance level of 0.05 may underestimate EVOS impact at oiled sites in Herring Bay and failure to achieve this significance level may overestimate recovery rates. The actual impact of EVOS may only be known when the ongoing Herring Bay Monitoring study has documented conditions on oiled and control sites following complete recovery.

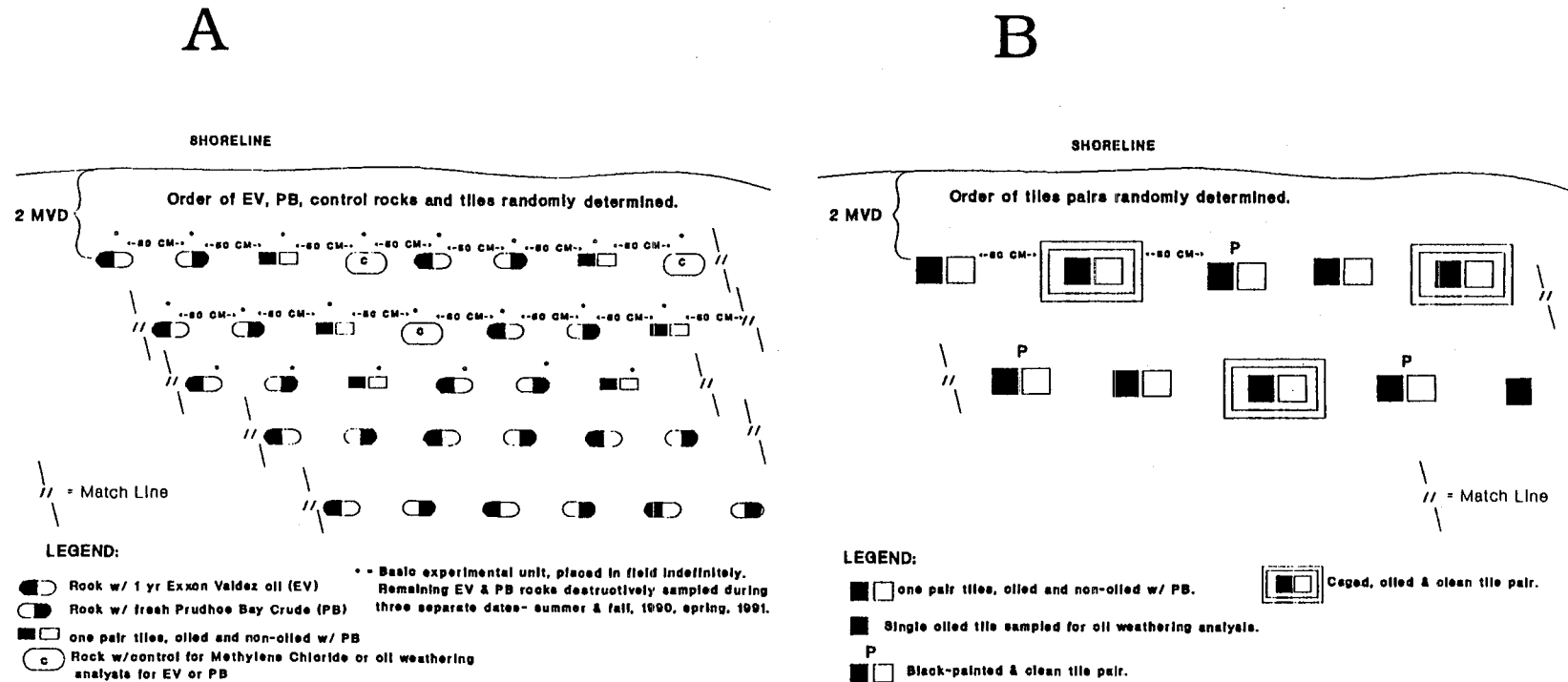

Figure 3.1. Diagrams depicting placement of oiled rocks and tile pairs in 1990 (a), and placement of oiled, clean, painted and caged tile pairs in 1991 (b). Units were placed randomly along the 2nd meter of vertical drop (MVD) from mean high high water. For the 1990 experiment (a) basic units (*) were quantified in the field, and extra EV & PB rocks were destructively sampled in the summer and fall of 1990 and spring of 1991. All tiles placed in 1991 were quantified in the field.

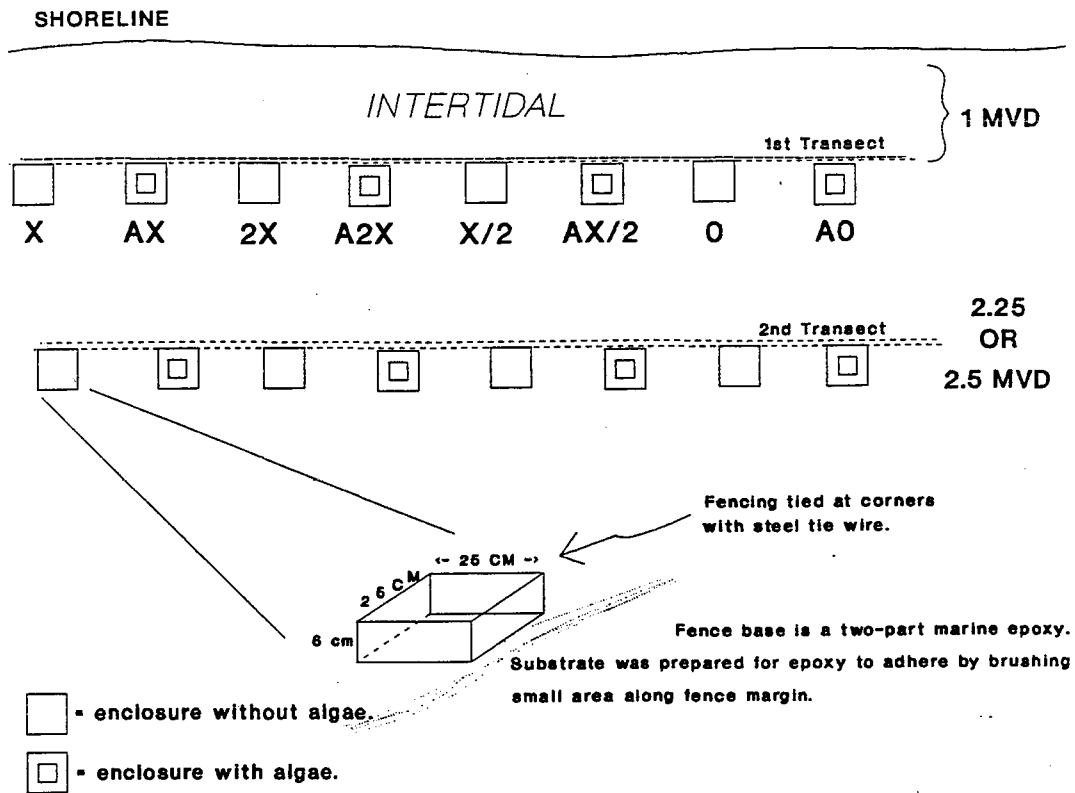

Figure 3.2. Schematic diagram depicting layout of the fences and cages used in the limpet grazing studies. Fences were placed at two contours, where cages were placed only at the 2nd meter of vertical drop (MVD) below mean high high water. Fences were placed at four pairs of control and oiled sites. Cages were placed at three pairs of sites. Half of the enclosures had algae removed, and the other half had algae retained ("A"). Other treatments consisted of varying limpet densities. X = mean density of limpets per 25 X 25 cm for a given contour. Other densities were twice (2X) and half (X/2) the mean density of limpets. Percent cover of the enclosures was monitored between 8 July and 10 September, 1990.

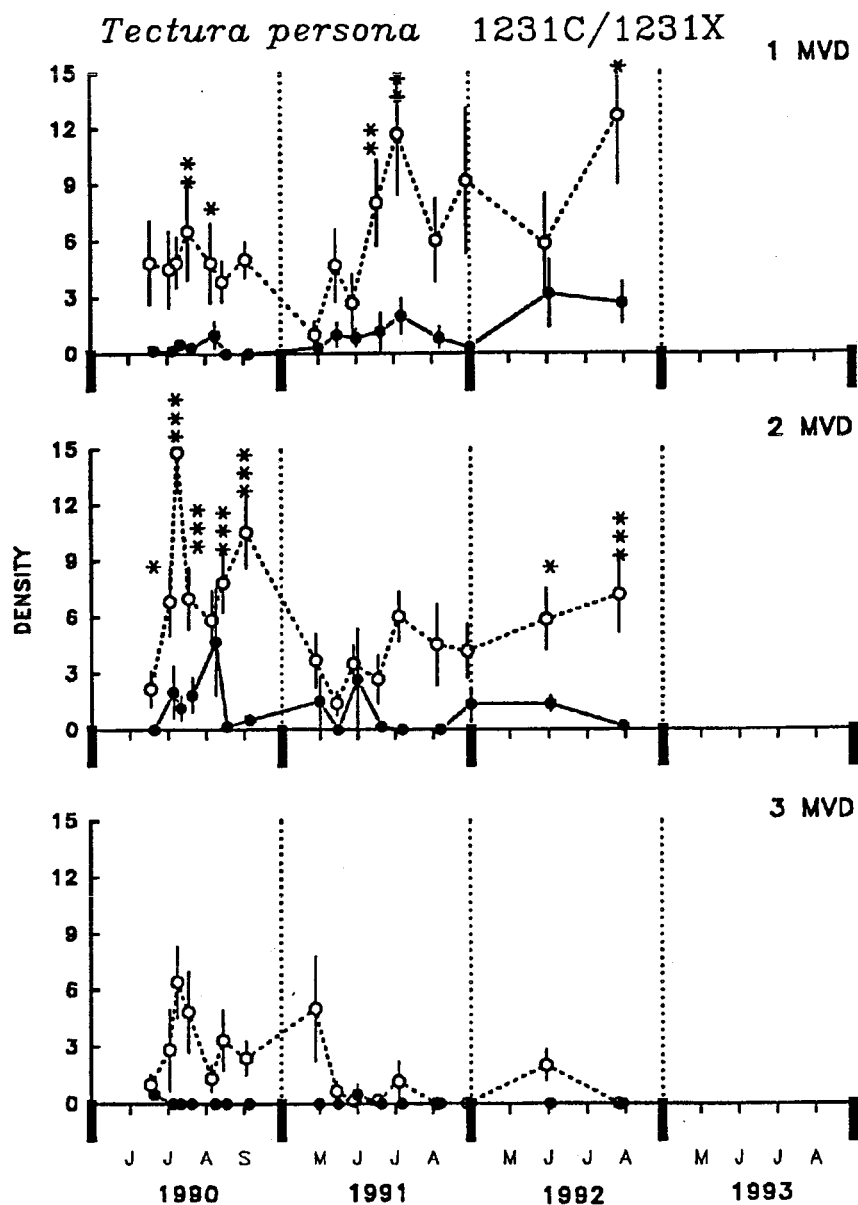

Figure 3.3. Density (No./0.1 m²) of the limpet *Tectura persona* at site pair 1231C/1231X at each tidal elevation for the 1990 to 1992 seasons. MVD refers to the meter of vertical drop below mean high high water. The oiled site is represented by solid circles and lines, and the control site is represented by open circles and dashed lines. The error bars represent one standard error of the mean. Asterisks over a given sample date indicate statistically significant differences between the sites. One asterisk represents $p \leq 0.05$; two asterisks represent $p \leq 0.025$ and three asterisks represent $p \leq 0.01$. Refer to Figure 2.3 for other layout details.

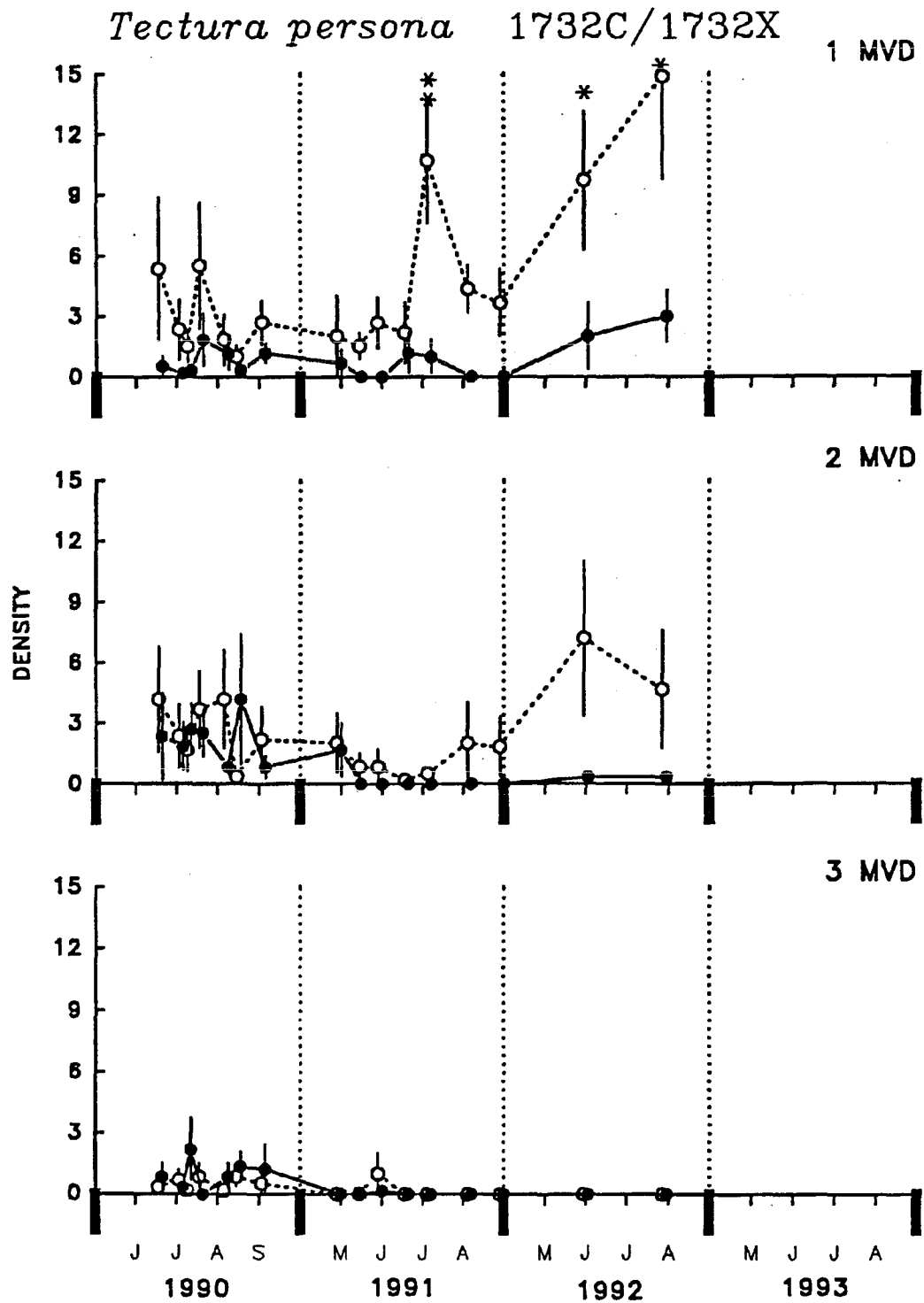

Figure 3.4. Density (No./0.1 m²) of the limpet *Tectura persona* at site pair 1732C/1732X at each tidal elevation for the 1990 to 1992 seasons. Layout same as Figure 3.3.

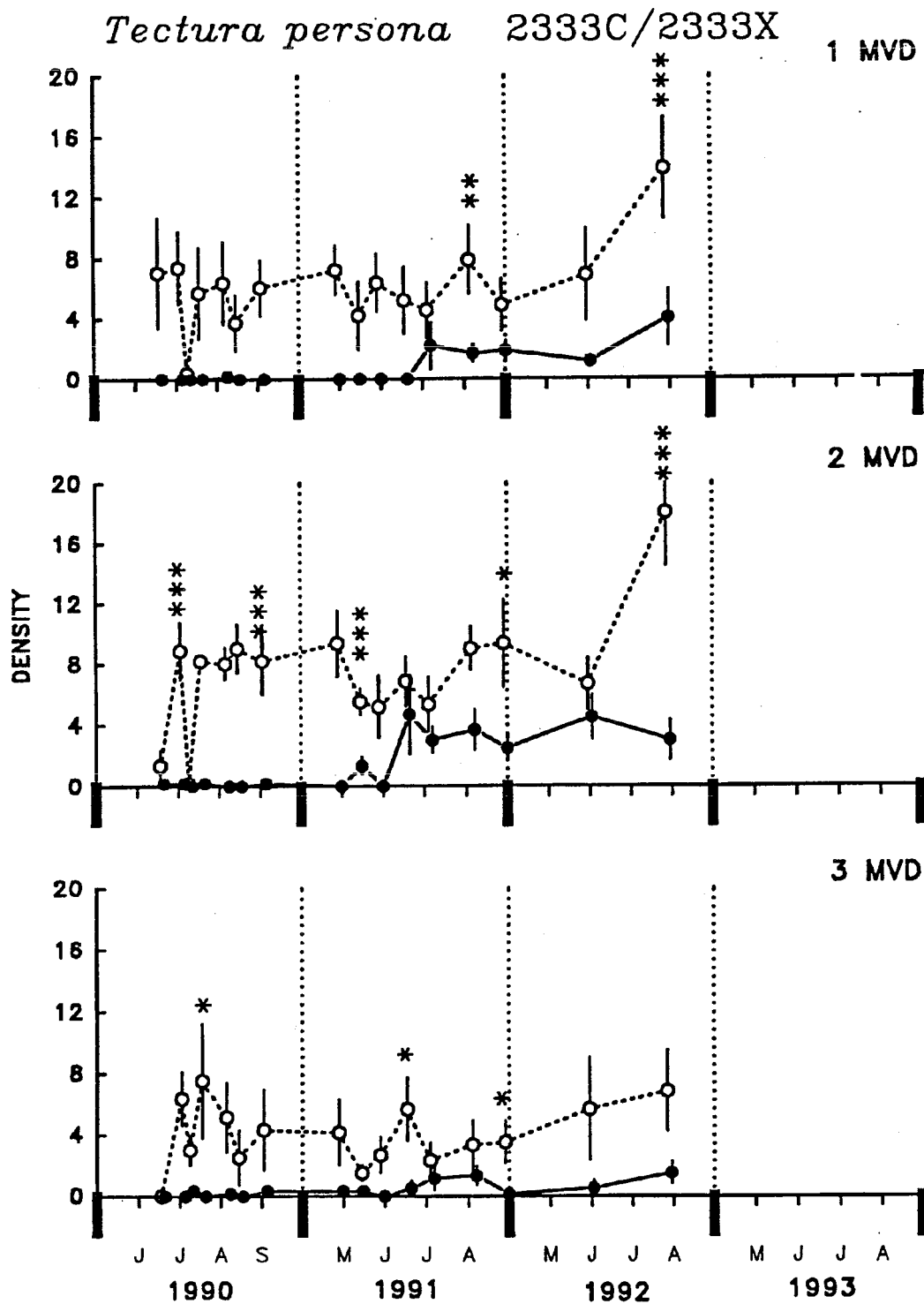

Figure 3.5. Density (No./0.1 m²) of the limpet *Tectura persona* at site pair 2333C/2333X at each tidal elevation for the 1990 to 1992 seasons. Layout same as Figure 3.3.

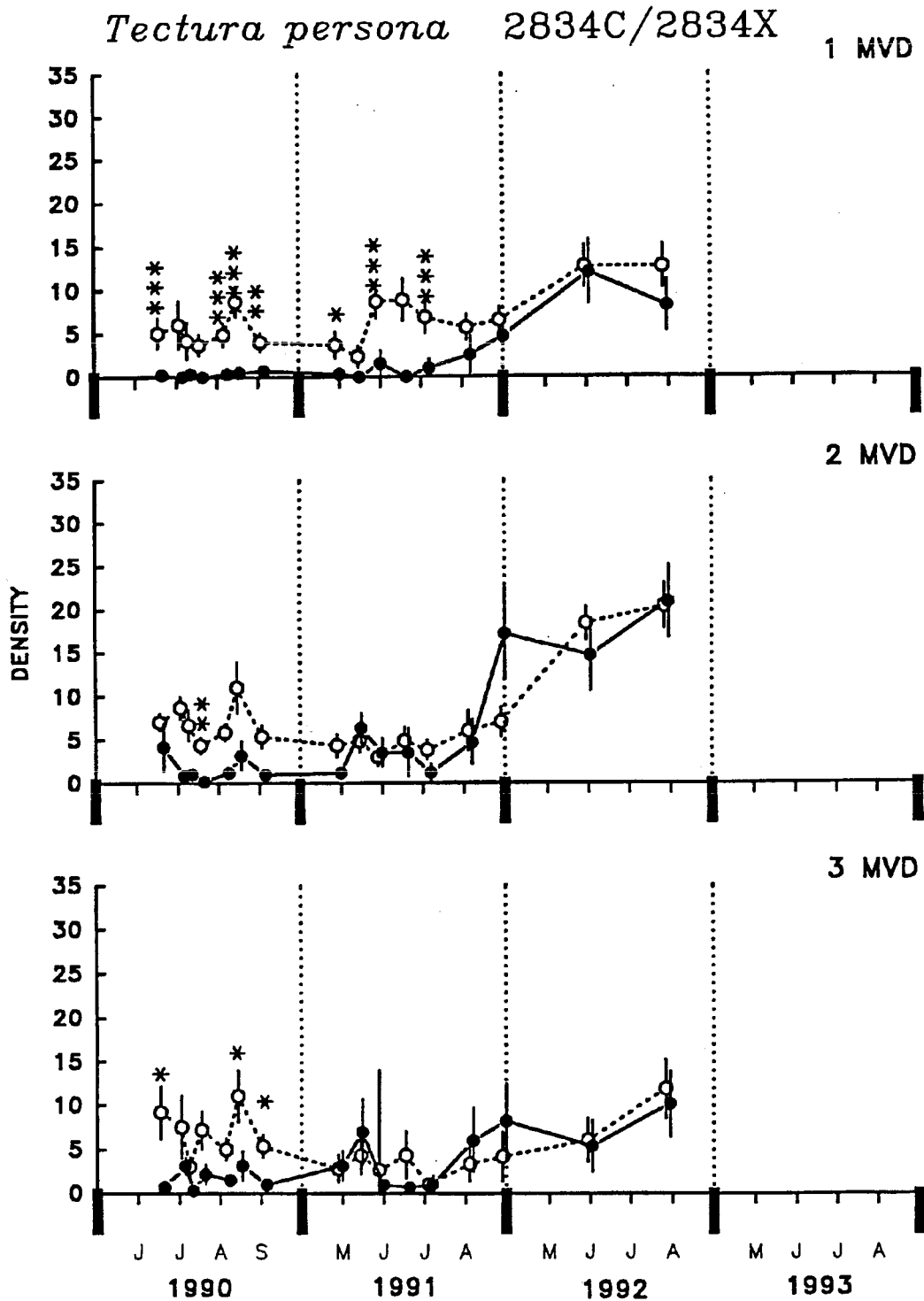

Figure 3.6. Density (No./0.1 m²) of the limpet *Tectura persona* at site pair 2834C/2834X at each tidal elevation for the 1990 to 1992 seasons. Layout same as Figure 3.3.

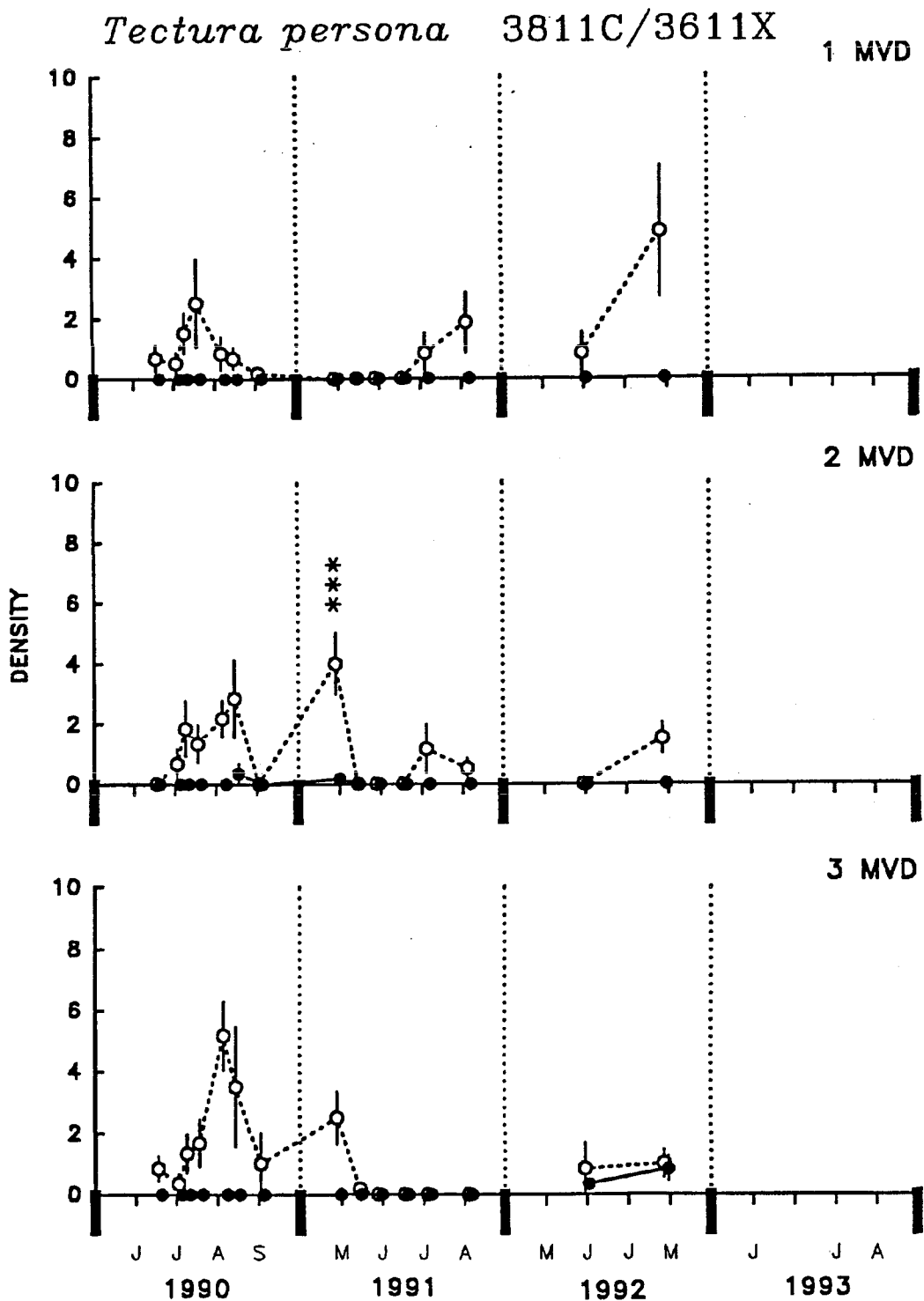

Figure 3.7. Density (No./0.1 m²) of the limpet *Tectura persona* at site pair 3811C/3611X at each tidal elevation for the 1990 to 1992 seasons. Layout same as Figure 3.3.

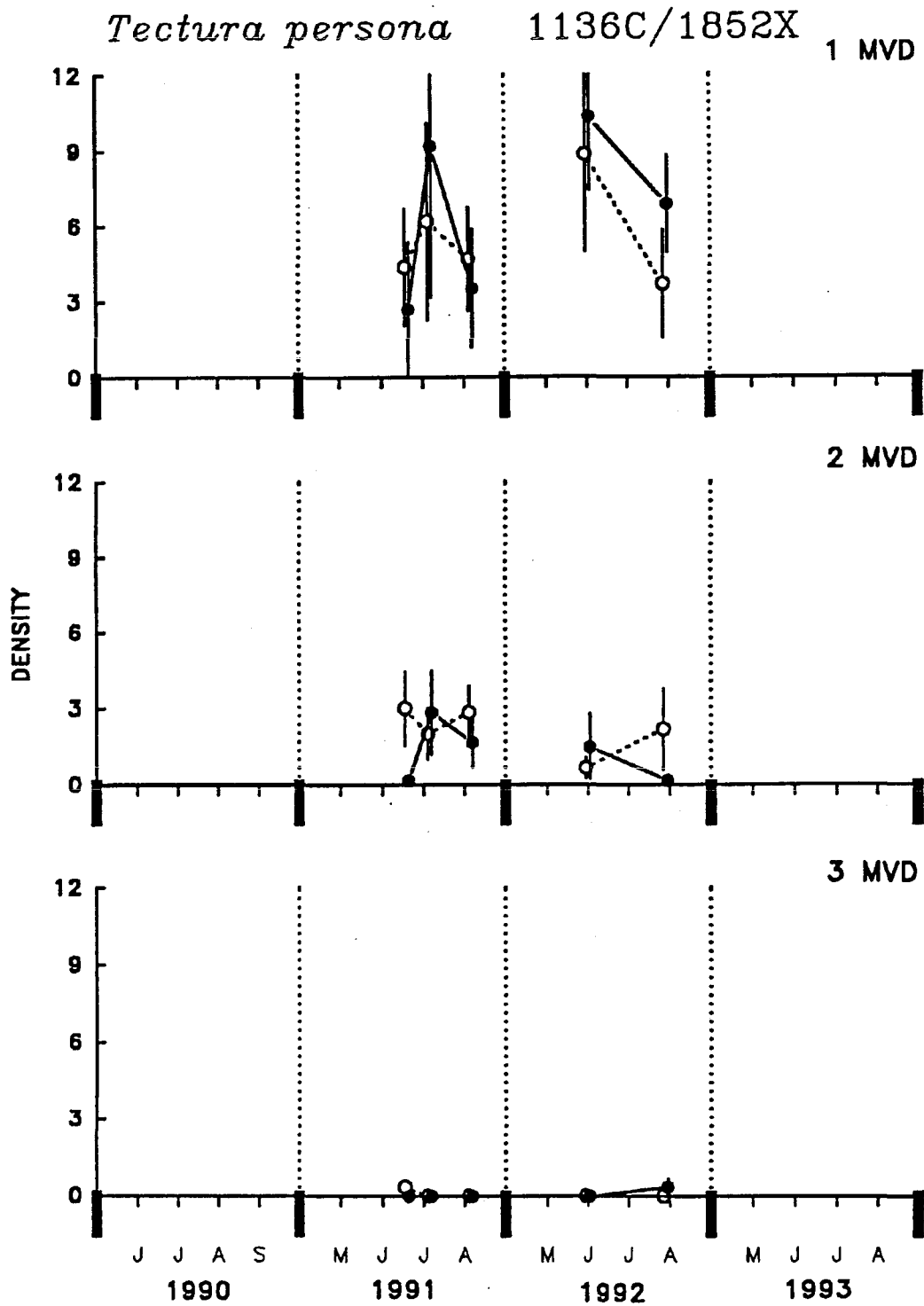

Figure 3.8. Density (No./0.1 m²) of the limpet *Tectura persona* at site pair 1136C/1852X at each tidal elevation for the 1991 to 1992 seasons. Layout same as Figure 3.3.

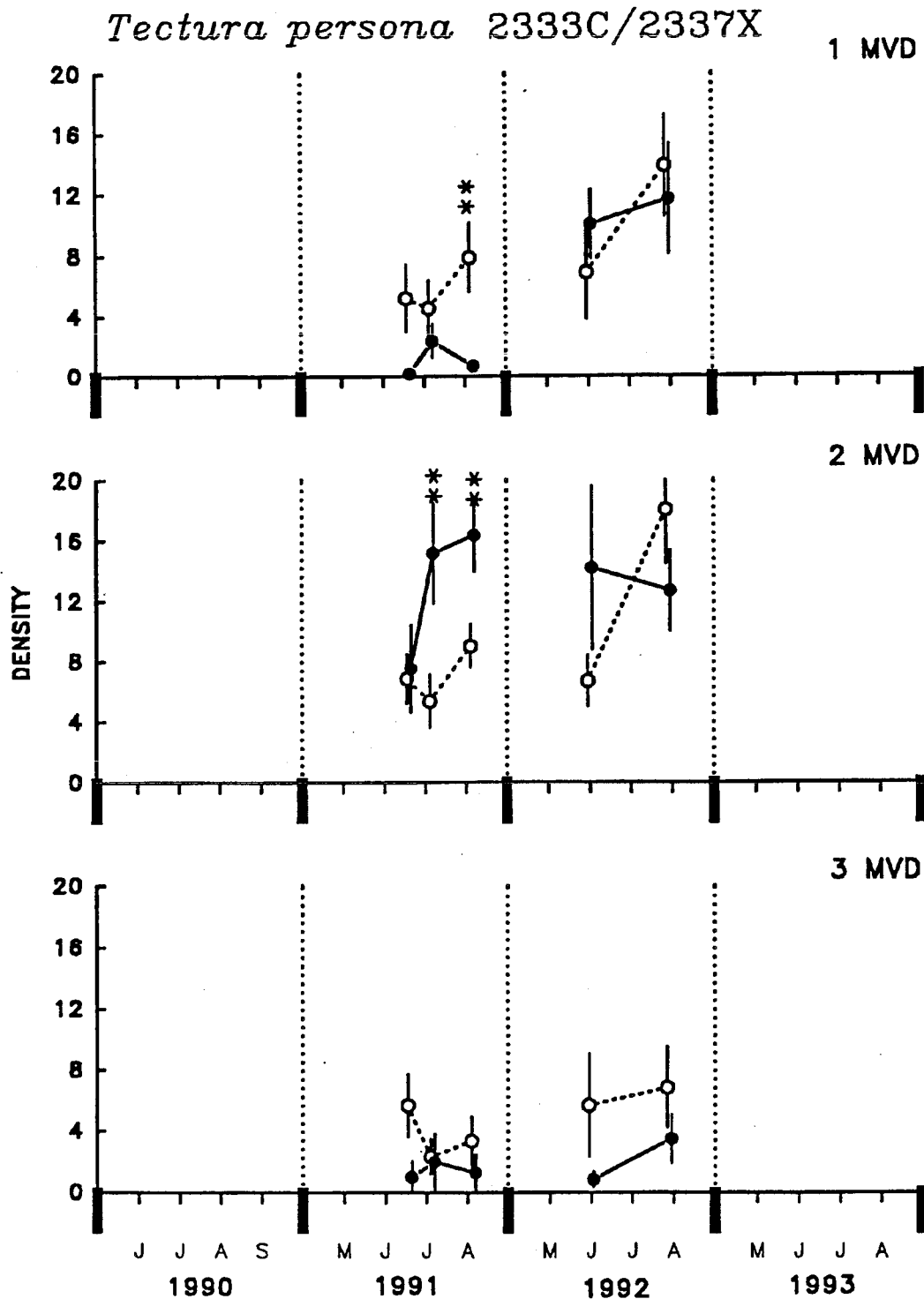

Figure 3.9. Density (No./0.1 m²) of the limpet *Tectura persona* at site pair 2333C/2337X at each tidal elevation for the 1991 to 1992 seasons. Layout same as Figure 3.3.

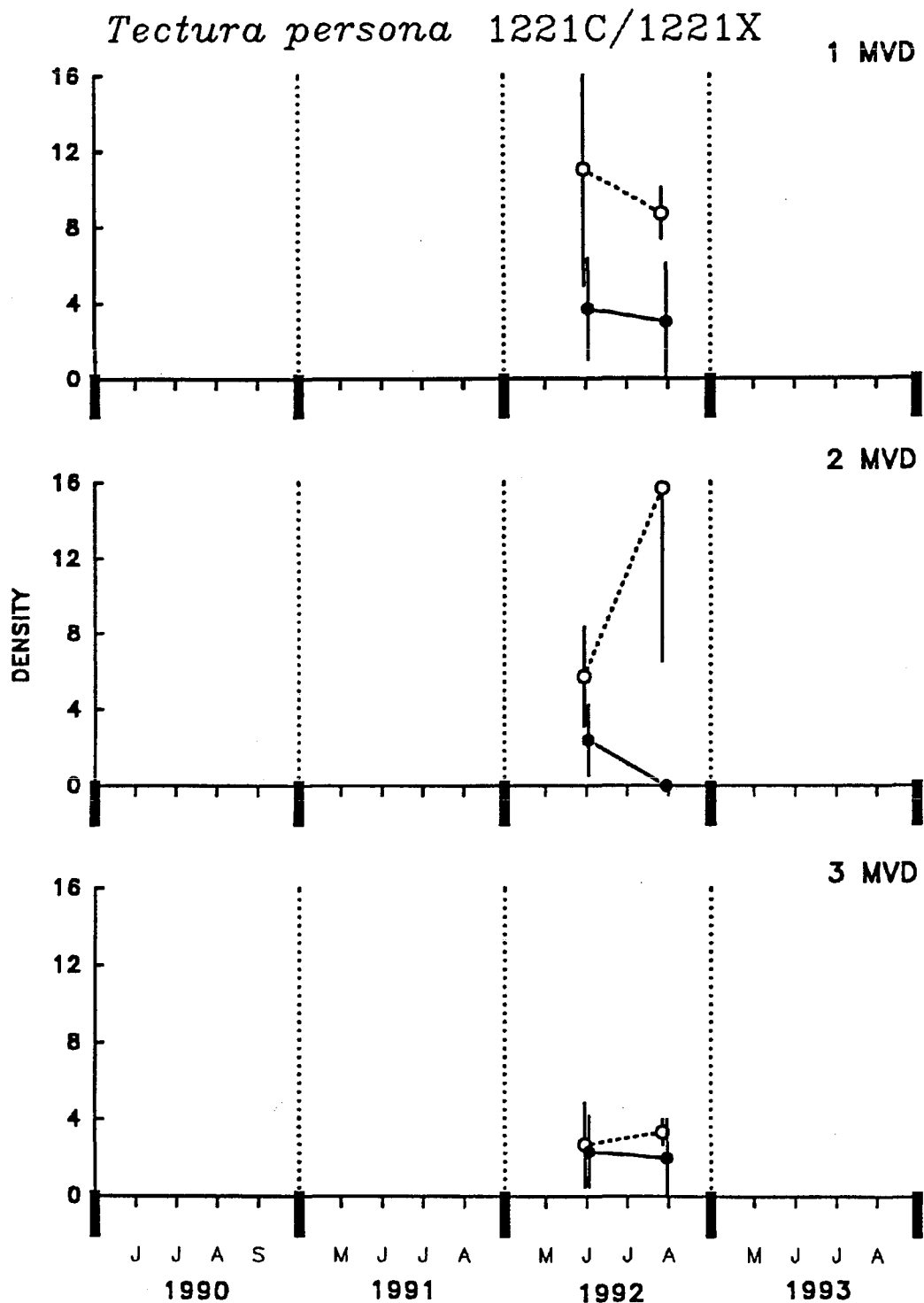

Figure 3.10. Density (No./0.1 m²) of the limpet *Tectura persona* at site pair 1221C/1221X at each tidal elevation during the 1992 season. Layout same as Figure 3.3.

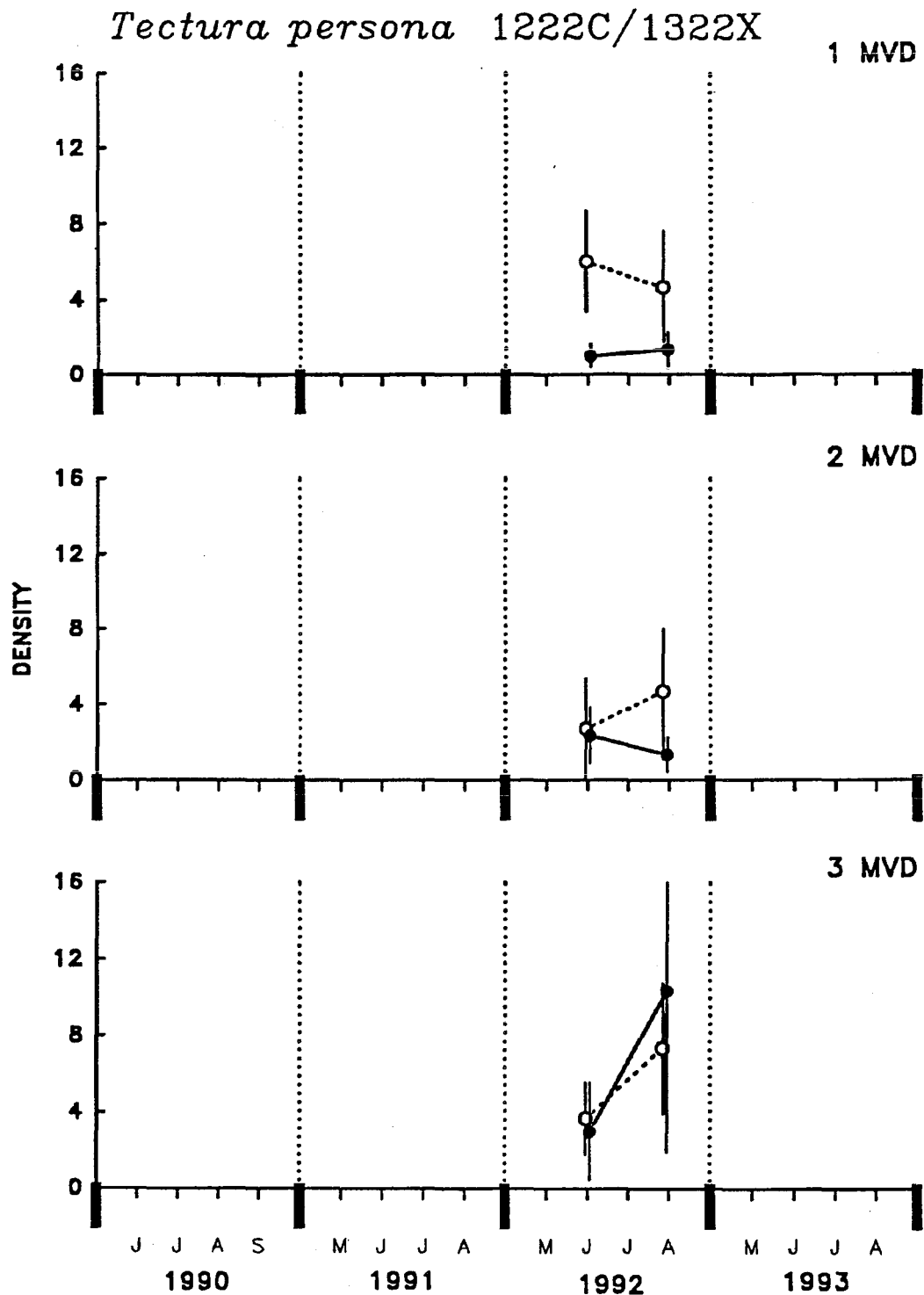

Figure 3.11. Density (No./0.1 m²) of the limpet *Tectura persona* at site pair 1222C/1322X at each tidal elevation during the 1992 season. Layout same as Figure 3.3.

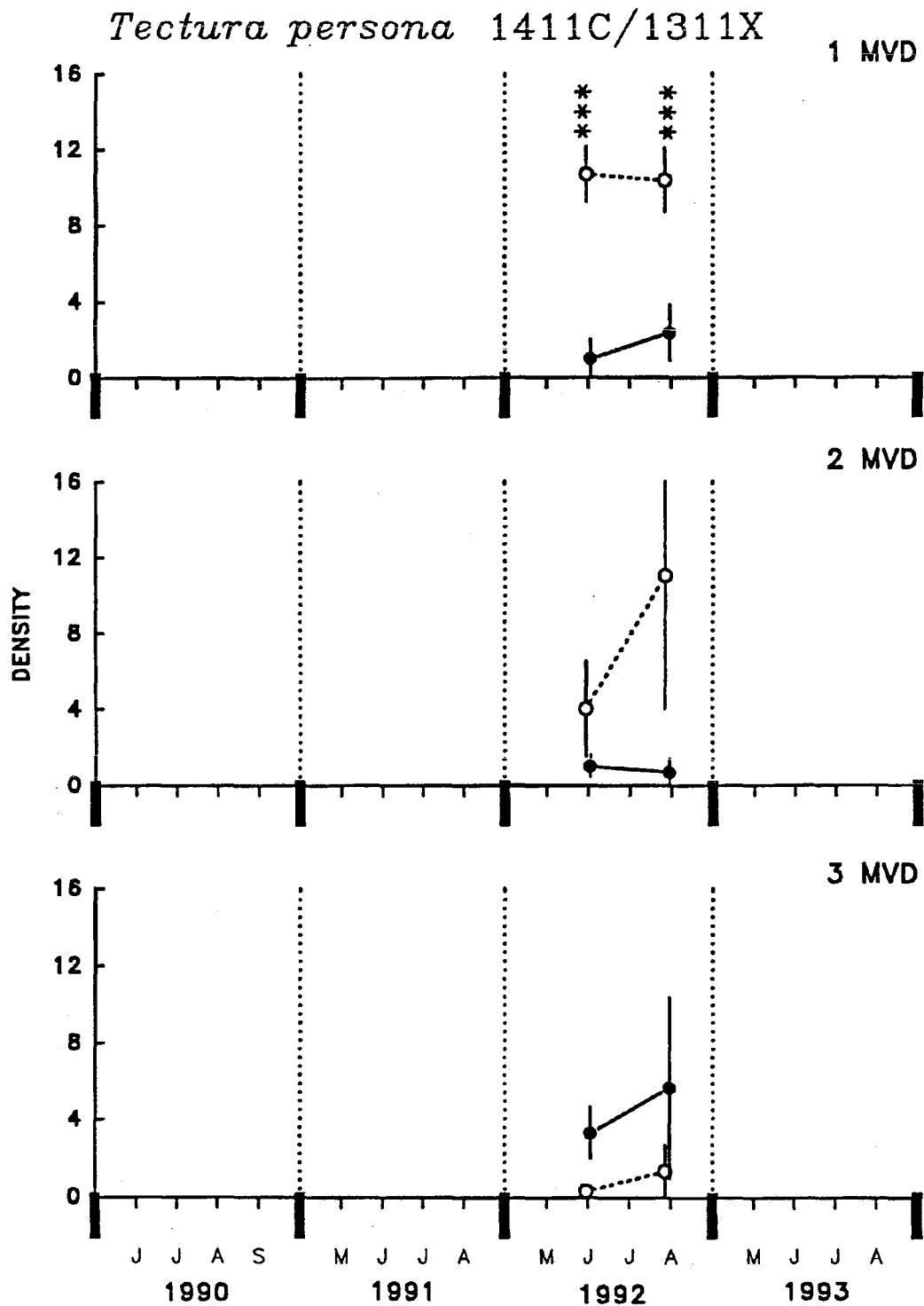

Figure 3.12. Density (No./0.1 m²) of the limpet *Tectura persona* at site pair 1411C/1311X at each tidal elevation during the 1992 season. Layout same as Figure 3.3.

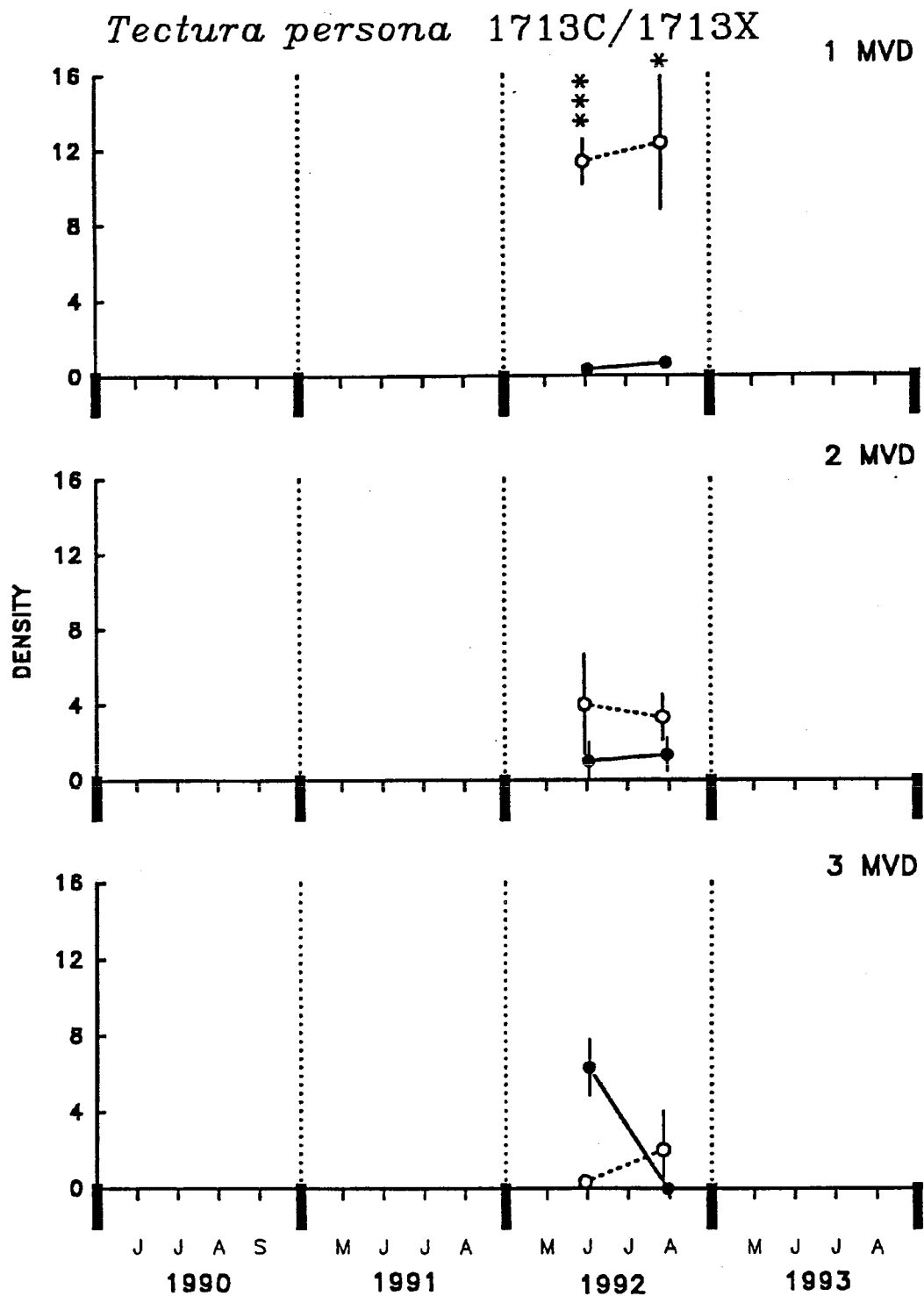

Figure 3.13. Density (No./0.1 m²) of the limpet *Tectura persona* at site pair 1713C/1713X at each tidal elevation during the 1992 season. Layout same as Figure 3.3.

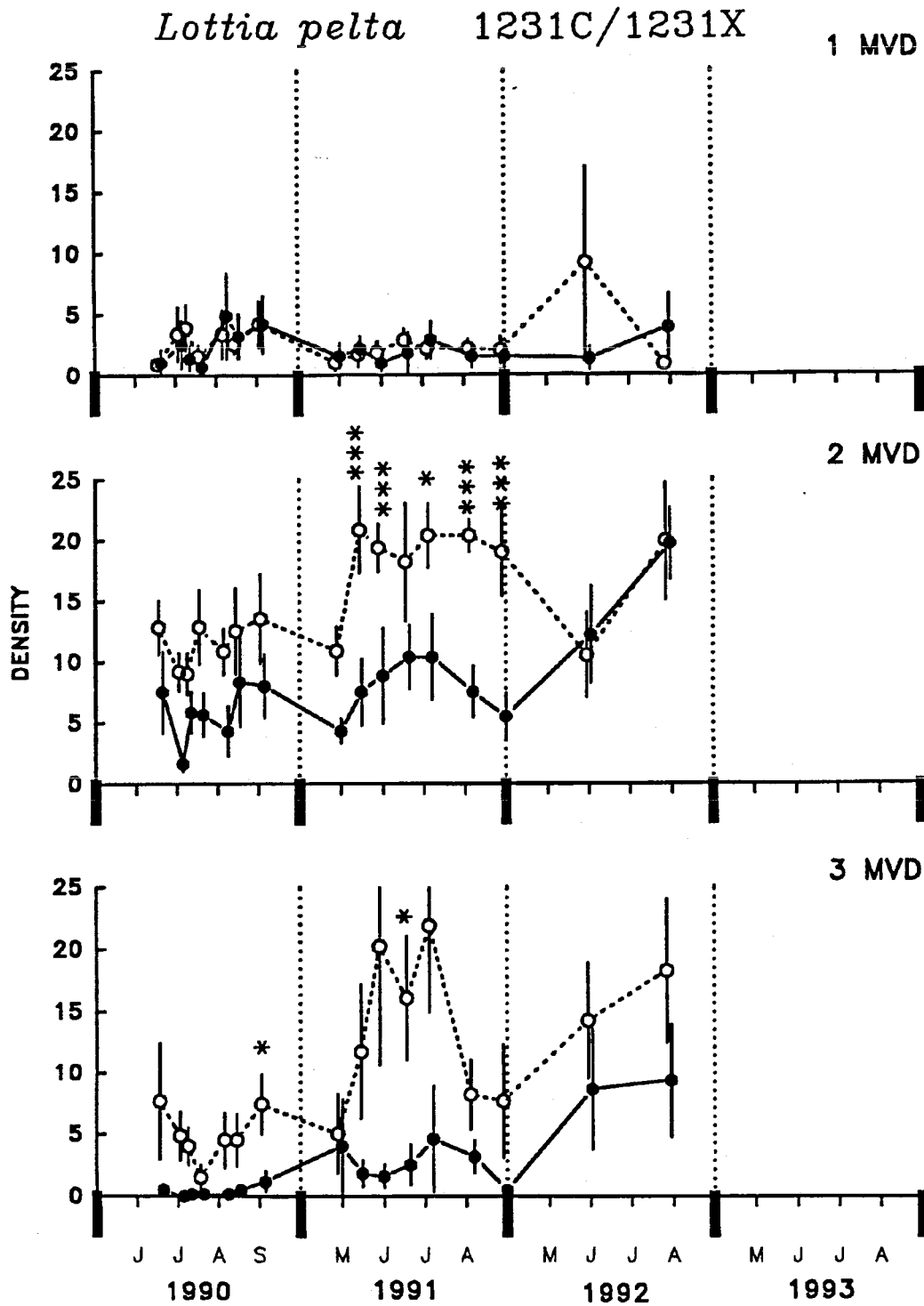

Figure 3.14. Density (No./0.1 m²) of the limpet *Lottia pelta* at site pair 1231C/1231X at each tidal elevation for the 1990 to 1992 seasons. Layout same as Figure 3.3.

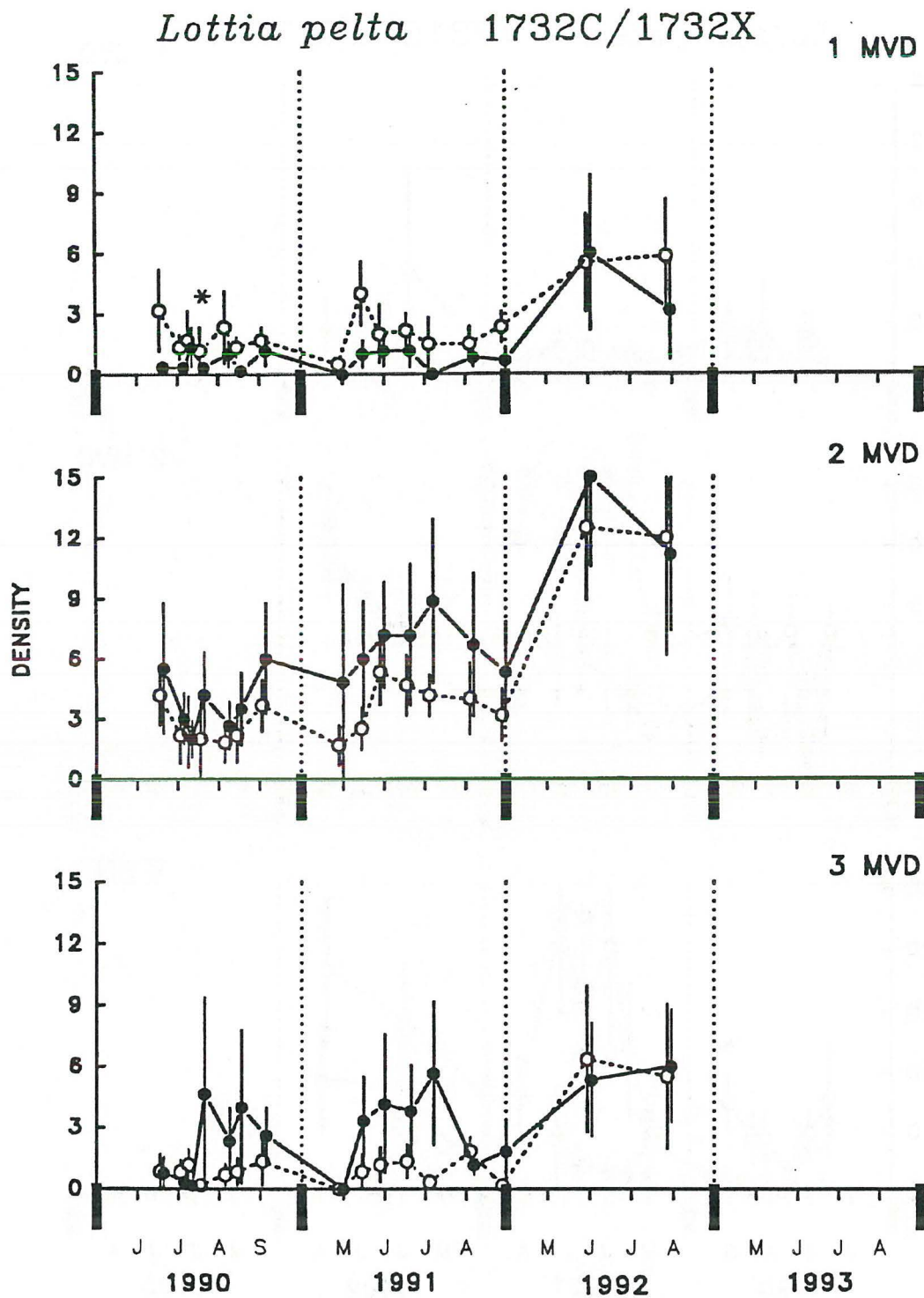

Figure 3.15. Density (No./0.1 m²) of the limpet *Lottia pelta* at site pair 1732C/1732X at each tidal elevation for the 1990 to 1992 season. Layout same as Figure 3.3.

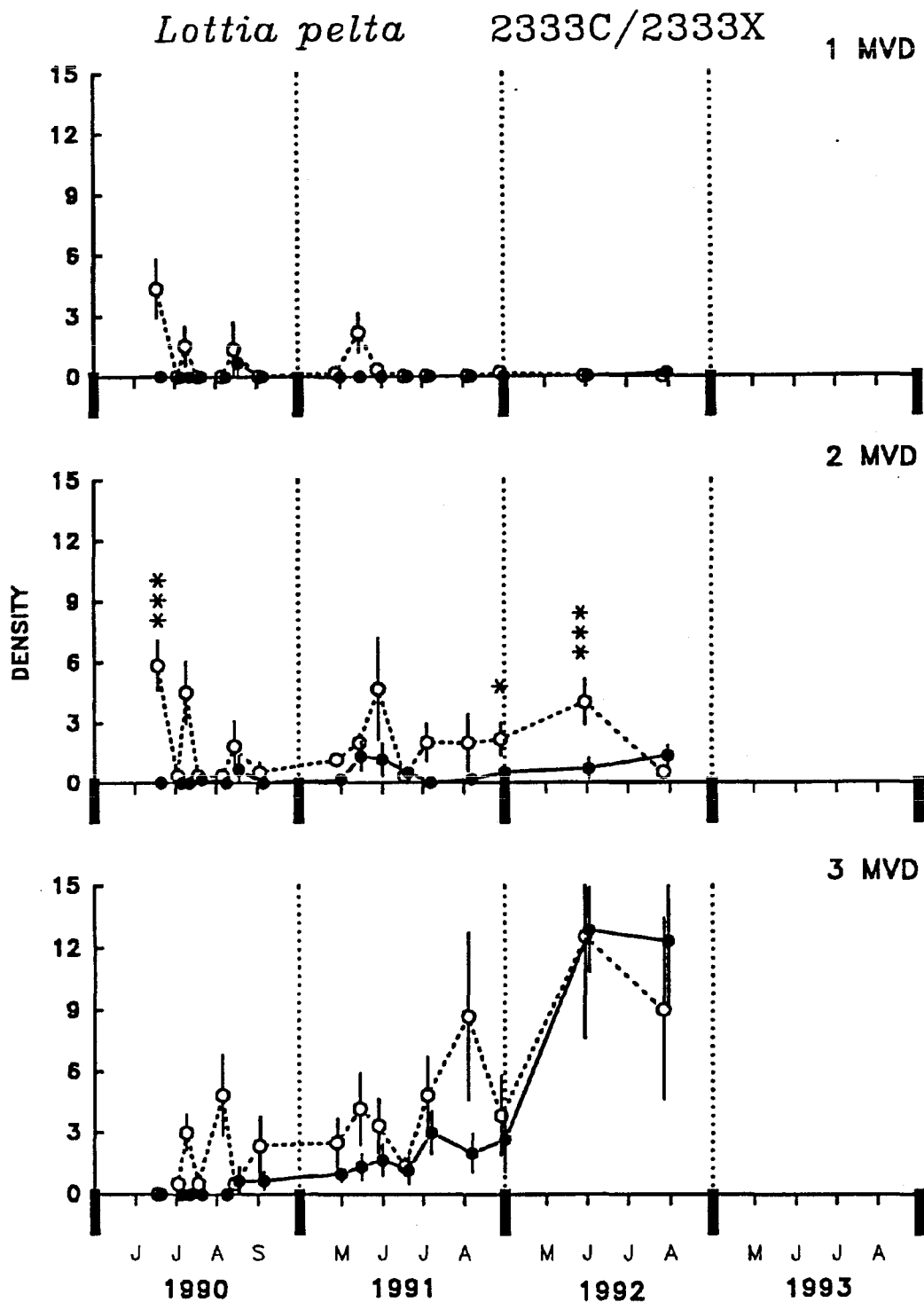

Figure 3.16. Density (No./0.1 m²) of the limpet *Lottia pelta* at site pair 2333C/2333X at each tidal elevation for the 1990 to 1992 seasons. Layout same as Figure 3.3.

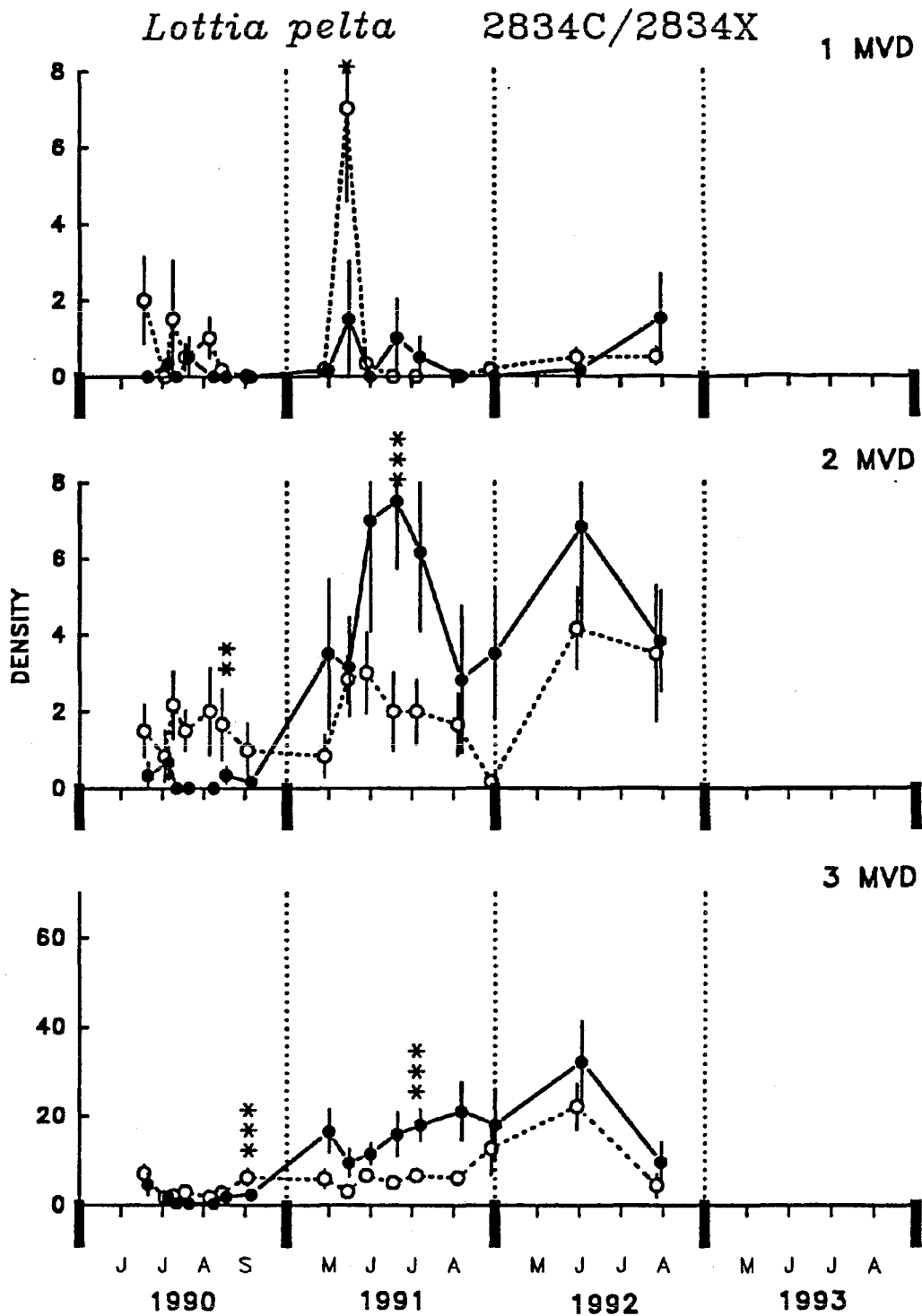

Figure 3.17. Density (No./0.1 m²) of the limpet *Lottia pelta* at site pair 2834C/2834X at each tidal elevation for the 1990 to 1992 seasons. Layout same as Figure 3.3.

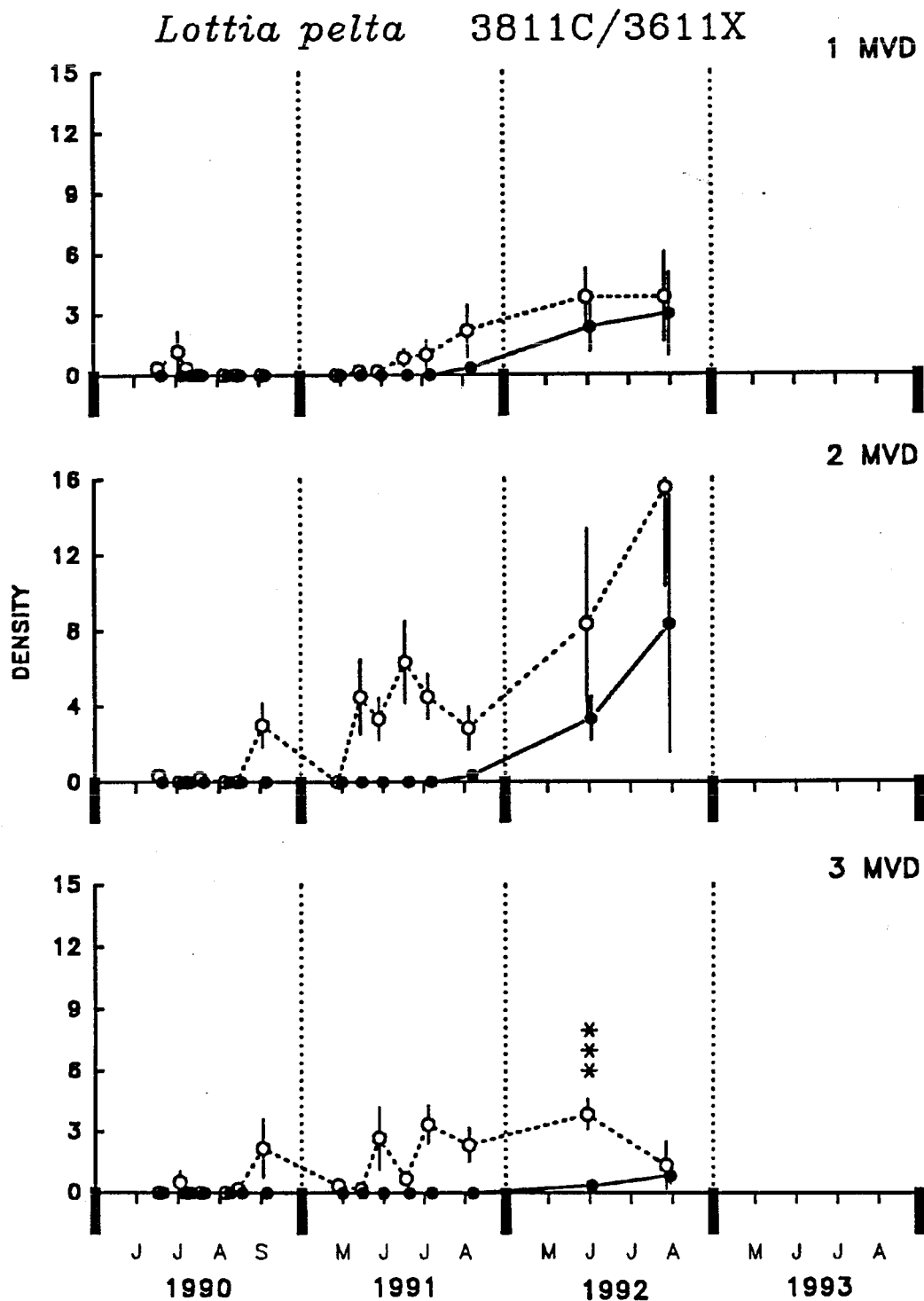

Figure 3.18. Density (No./0.1 m²) of the limpet *Lottia pelta* at site pair 3811C/3611X at each tidal elevation for the 1990 to 1992 seasons. Layout same as Figure 3.3.

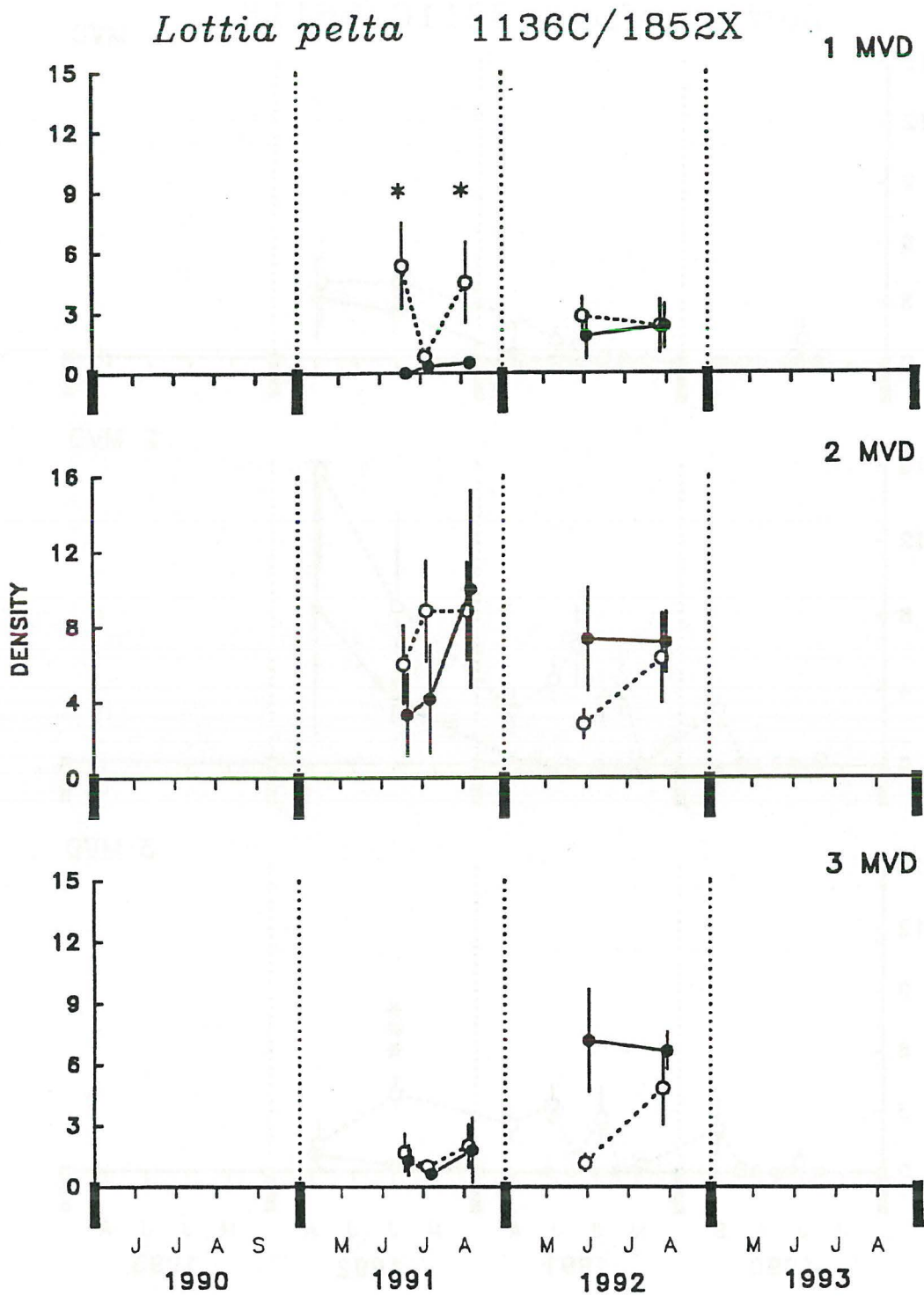

Figure 3.19. Density (No./0.1 m²) of the limpet *Lottia pelta* at site pair 1136C/1852X at each tidal elevation for the 1991 to 1992 seasons. Layout same as Figure 3.3.

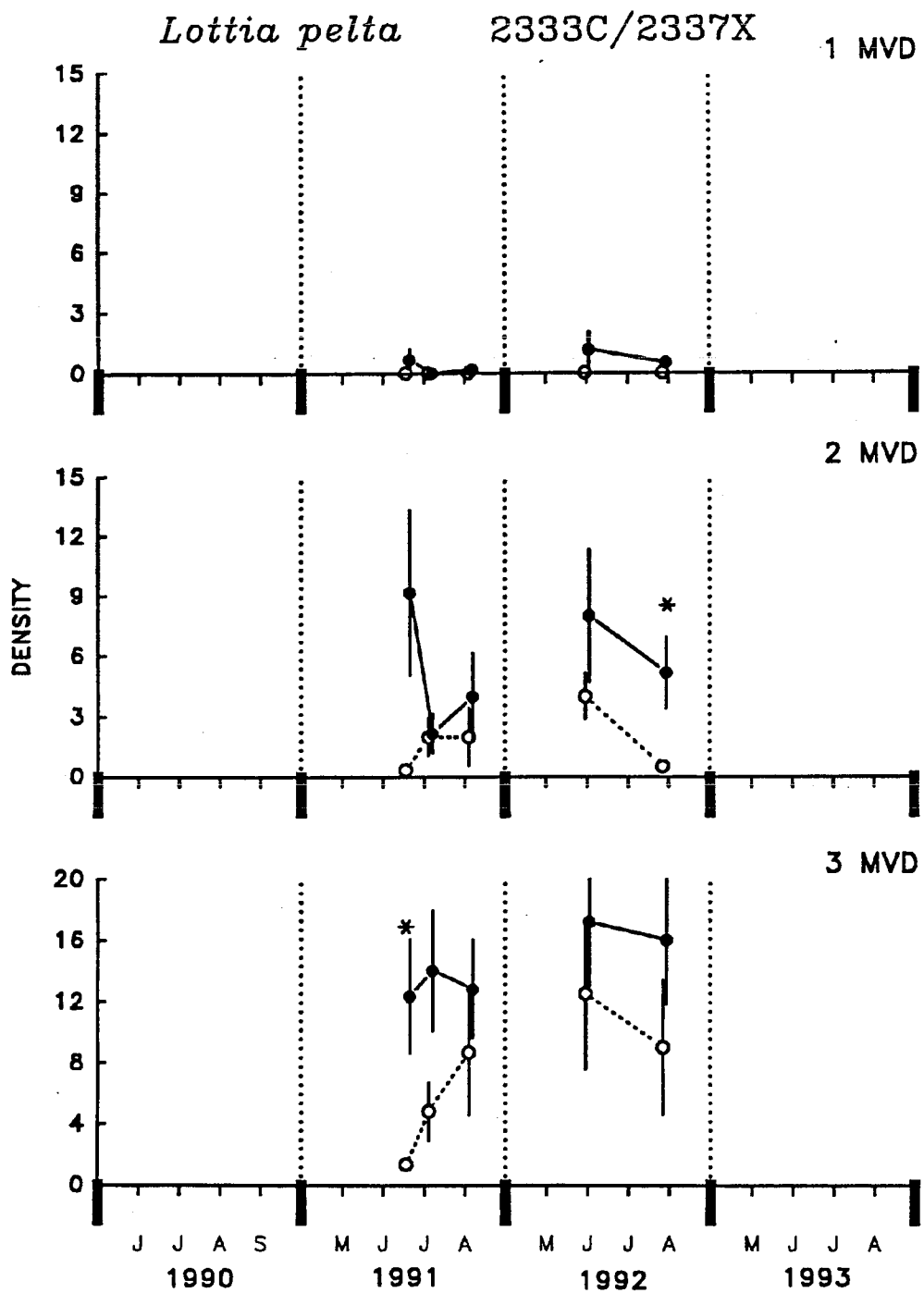

Figure 3.20. Density (No./0.1 m²) of the limpet *Lottia pelta* at site pair 2333C/2337X at each tidal elevation for the 1991 to 1992 seasons. Layout same as Figure 3.3.

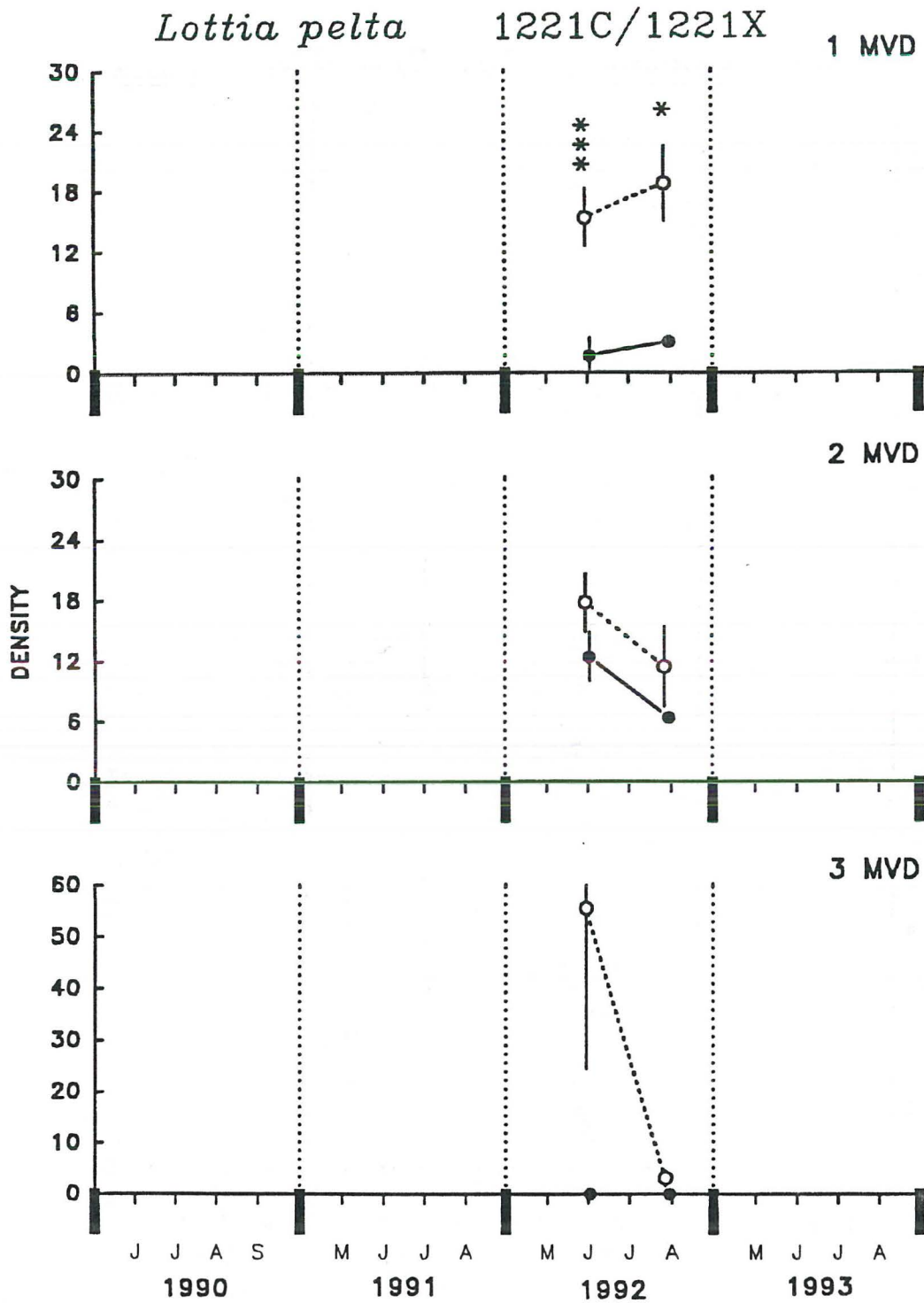

Figure 3.21. Density (No./0.1 m²) of the limpet *Lottia pelta* at site pair 1221C/1221X at each tidal elevation during the 1992 season. Layout same as Figure 3.3.

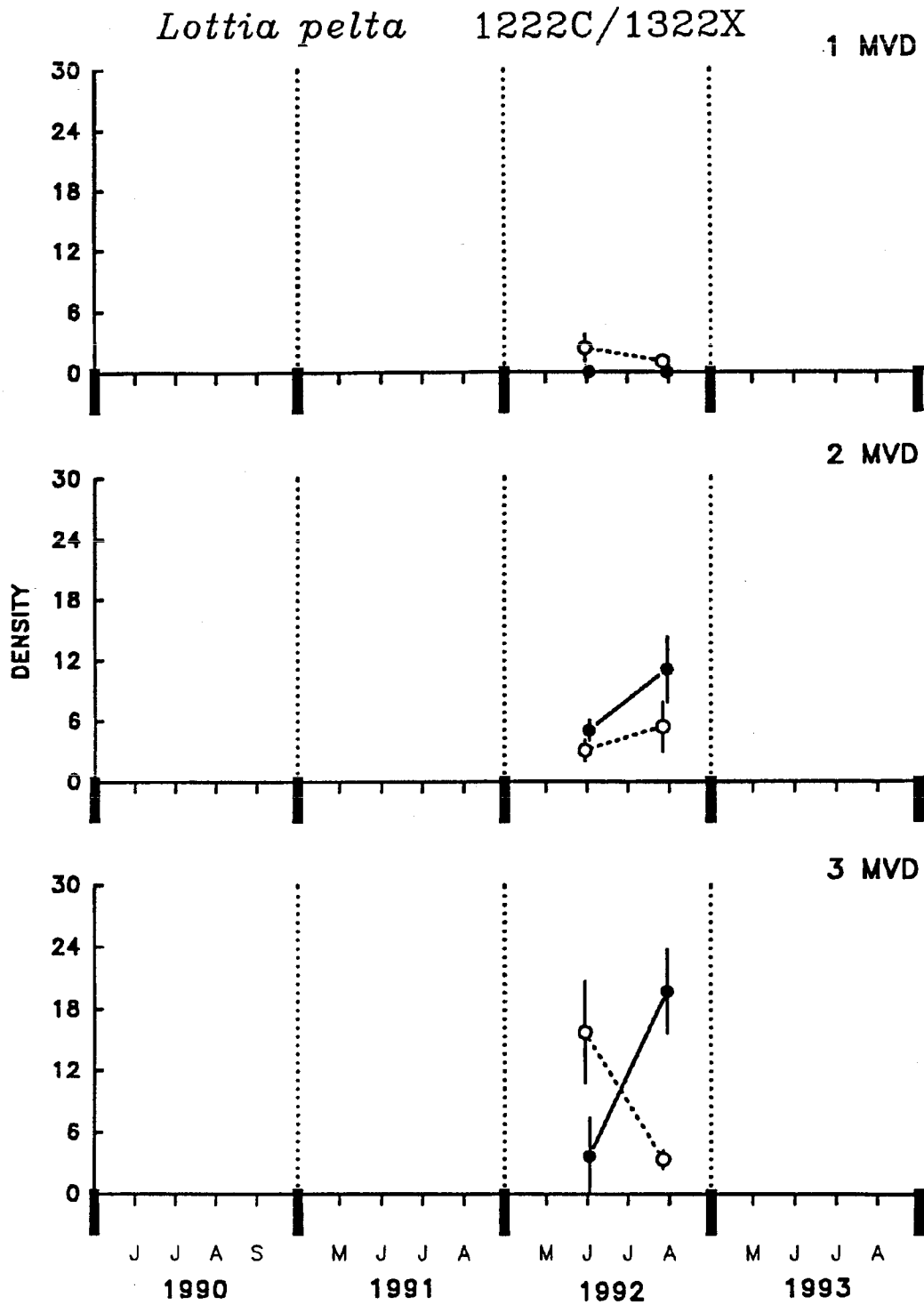

Figure 3.22. Density (No./0.1 m²) of the limpet *Lottia pelta* at site pair 1222C/1322X at each tidal elevation during the 1992 season. Layout same as Figure 3.3.

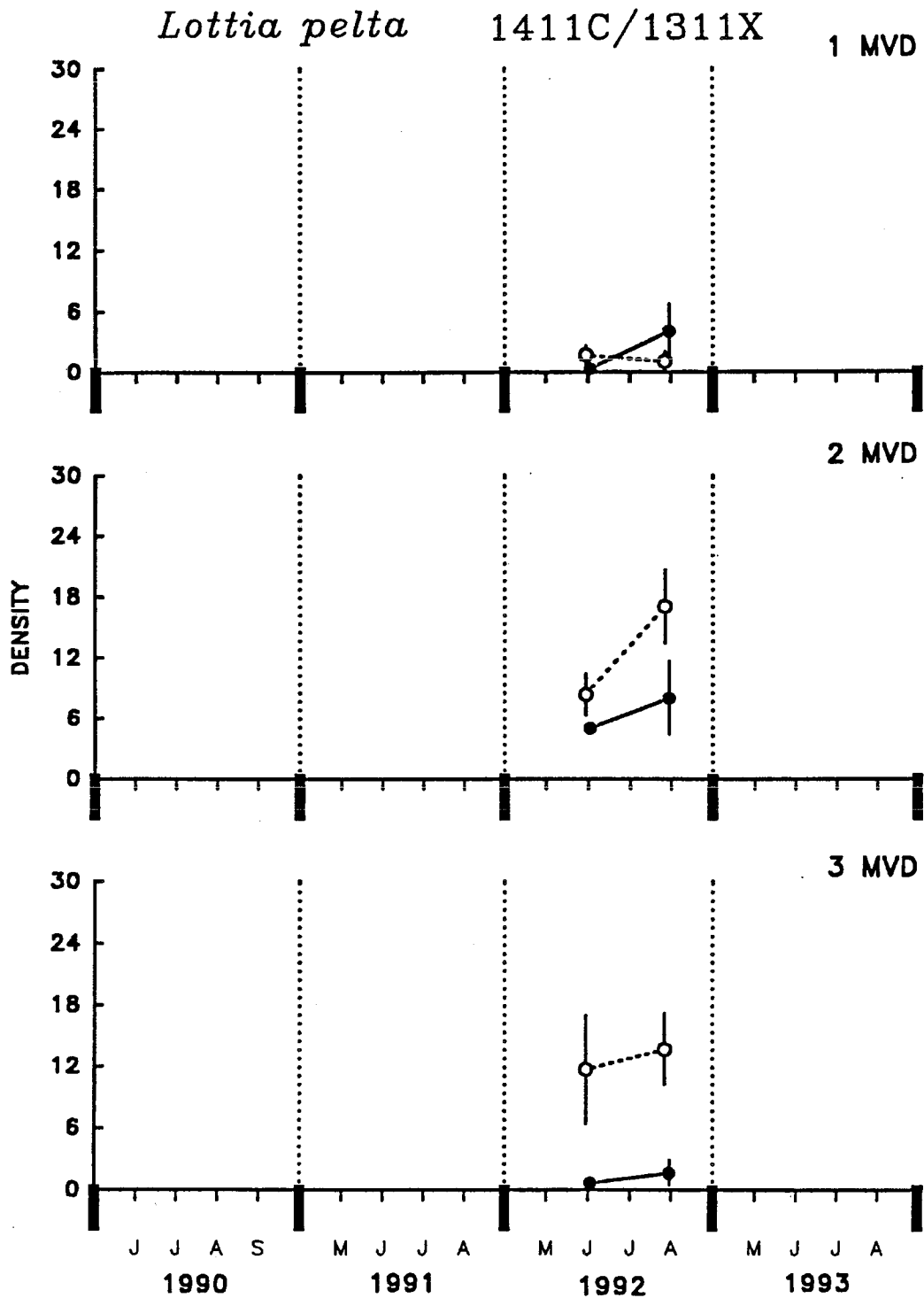

Figure 3.23. Density (No./0.1 m²) of the limpet *Lottia pelta* at site pair 1411C/1311X at each tidal elevation during the 1992 season. Layout same as Figure 3.3.

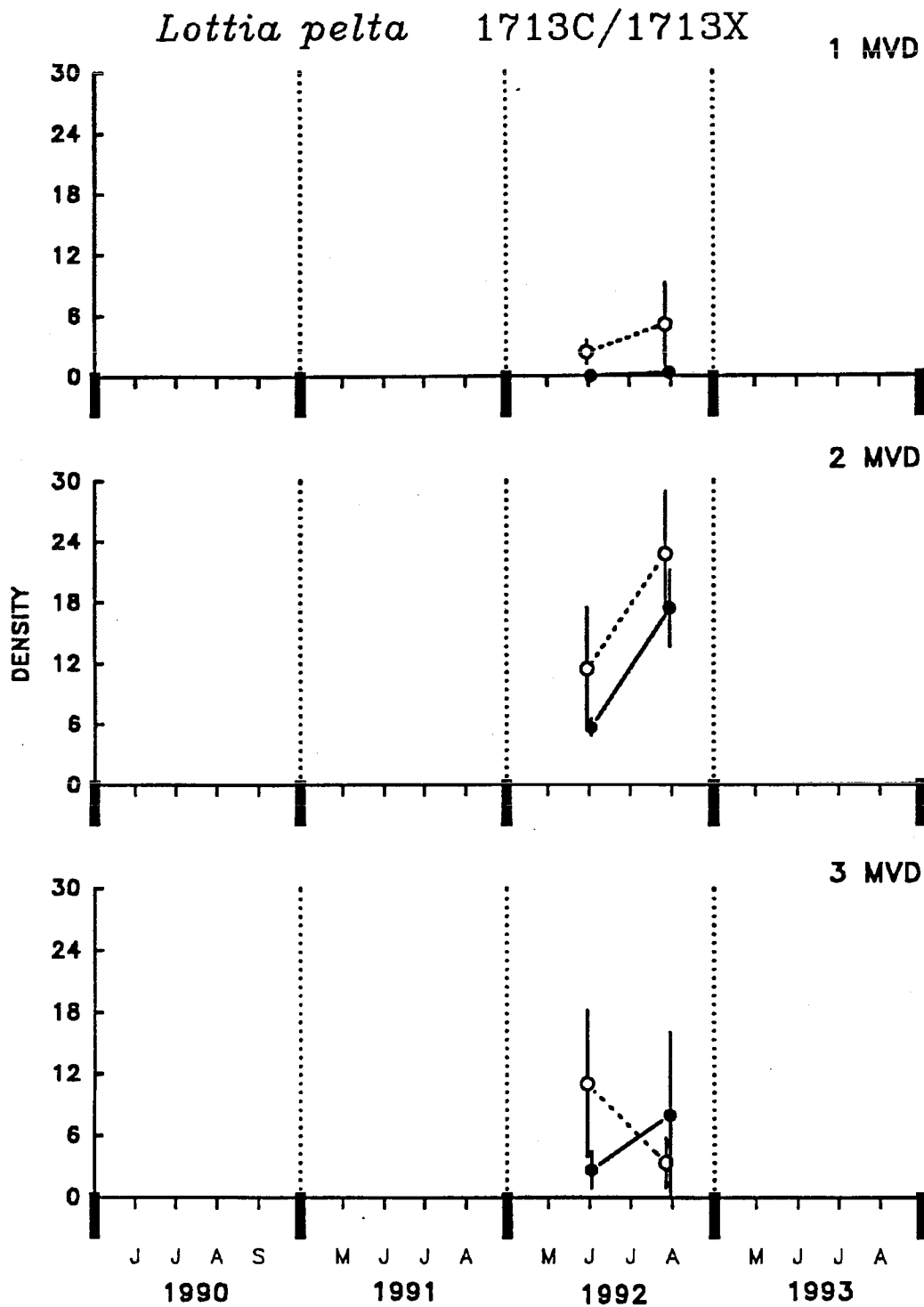

Figure 3.24. Density (No./0.1 m²) of the limpet *Lottia pelta* at site pair 1713C/1713X at each tidal elevation during the 1992 season. Layout same as Figure 3.3.

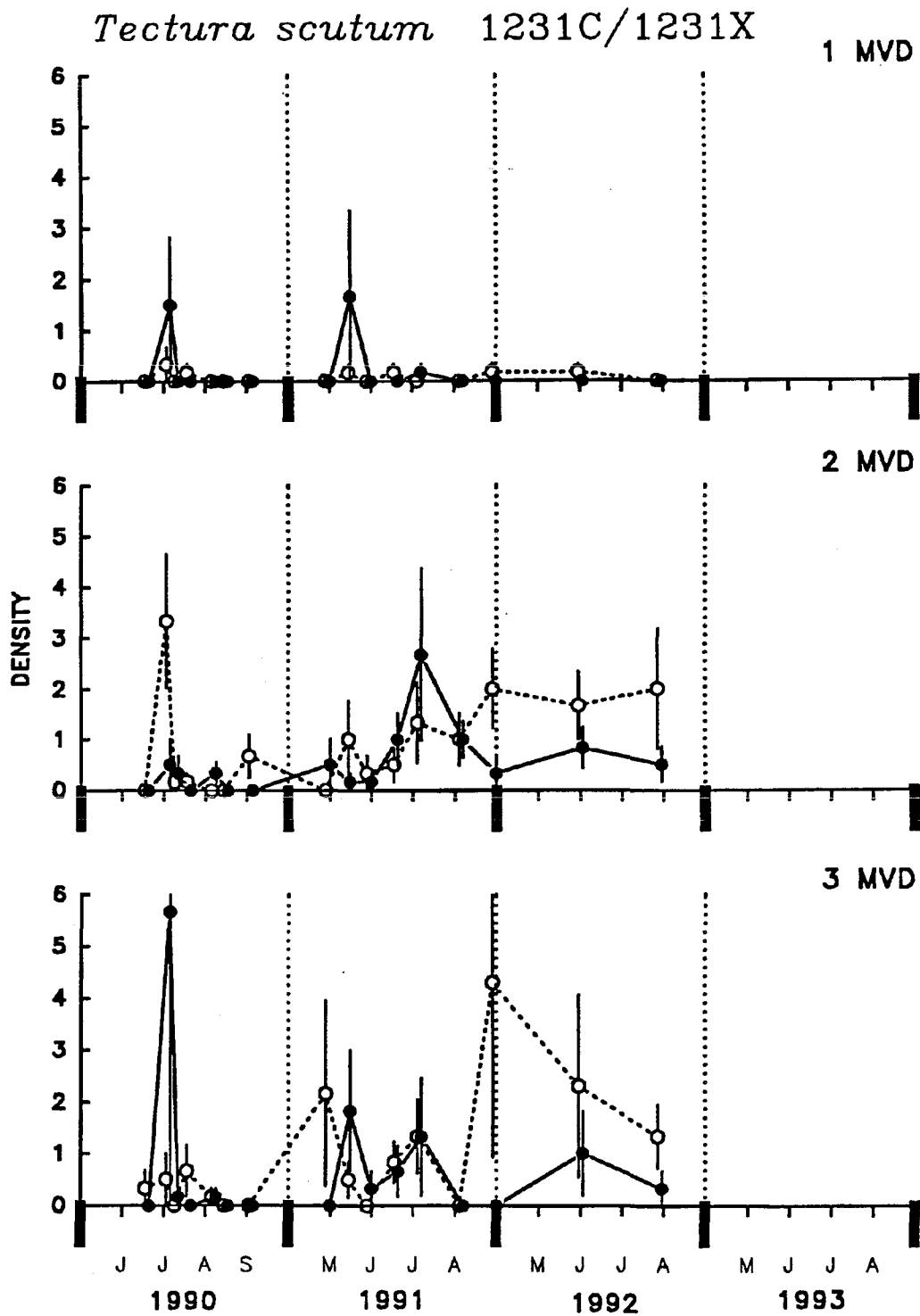

Figure 3.25. Density (No./0.1 m²) of the limpet *Tectura scutum* at site pair 1231C/1231X at each tidal elevation for the 1990 to 1992 seasons. Layout same as Figure 3.3.

Tectura scutum 1732C/1732X

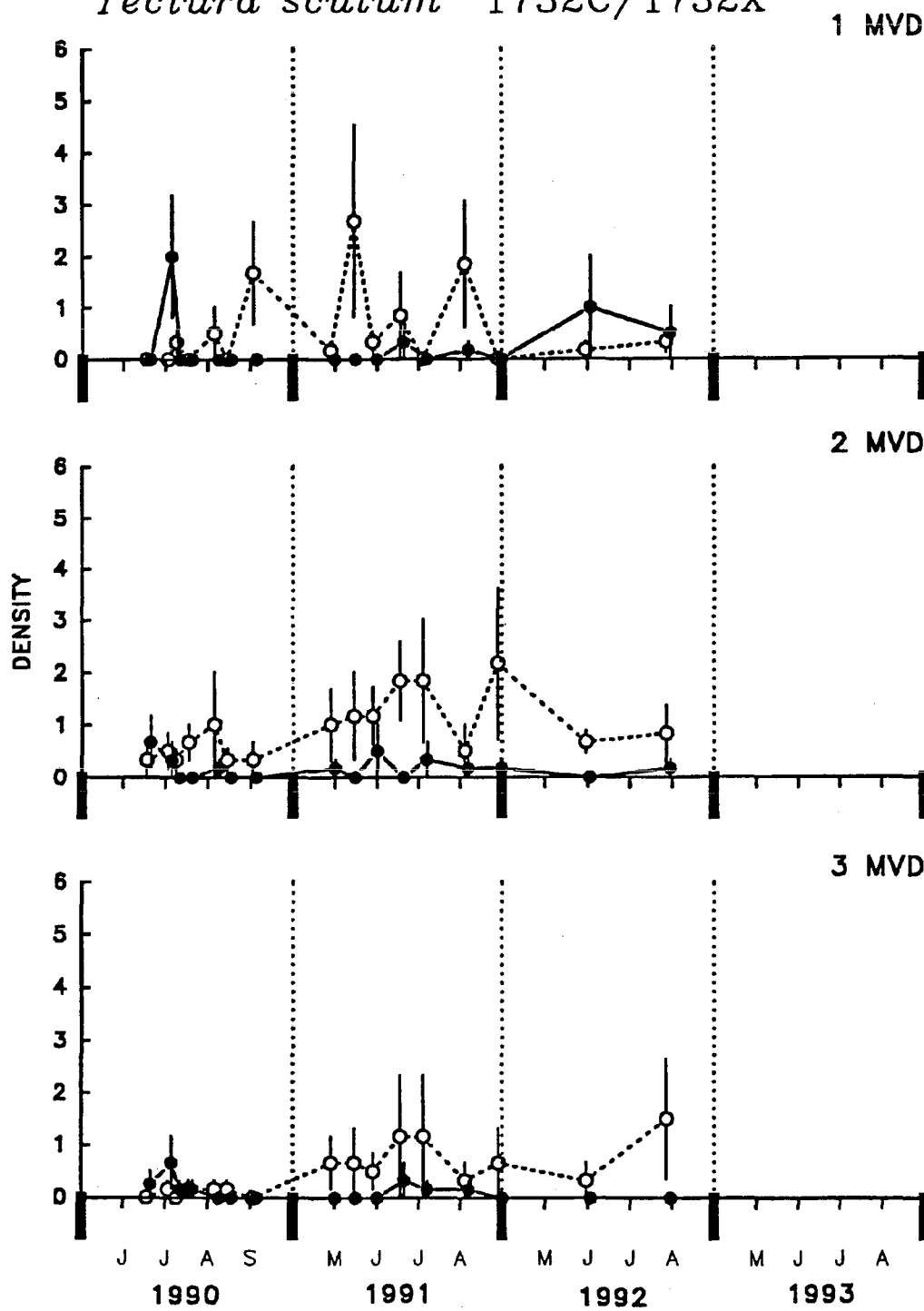

Figure 3.26. Density (No./0.1 m²) of the limpet *Tectura scutum* at site pair 1732C/1732X at each tidal elevation for the 1990 to 1992 seasons. Layout same as Figure 3.3. f

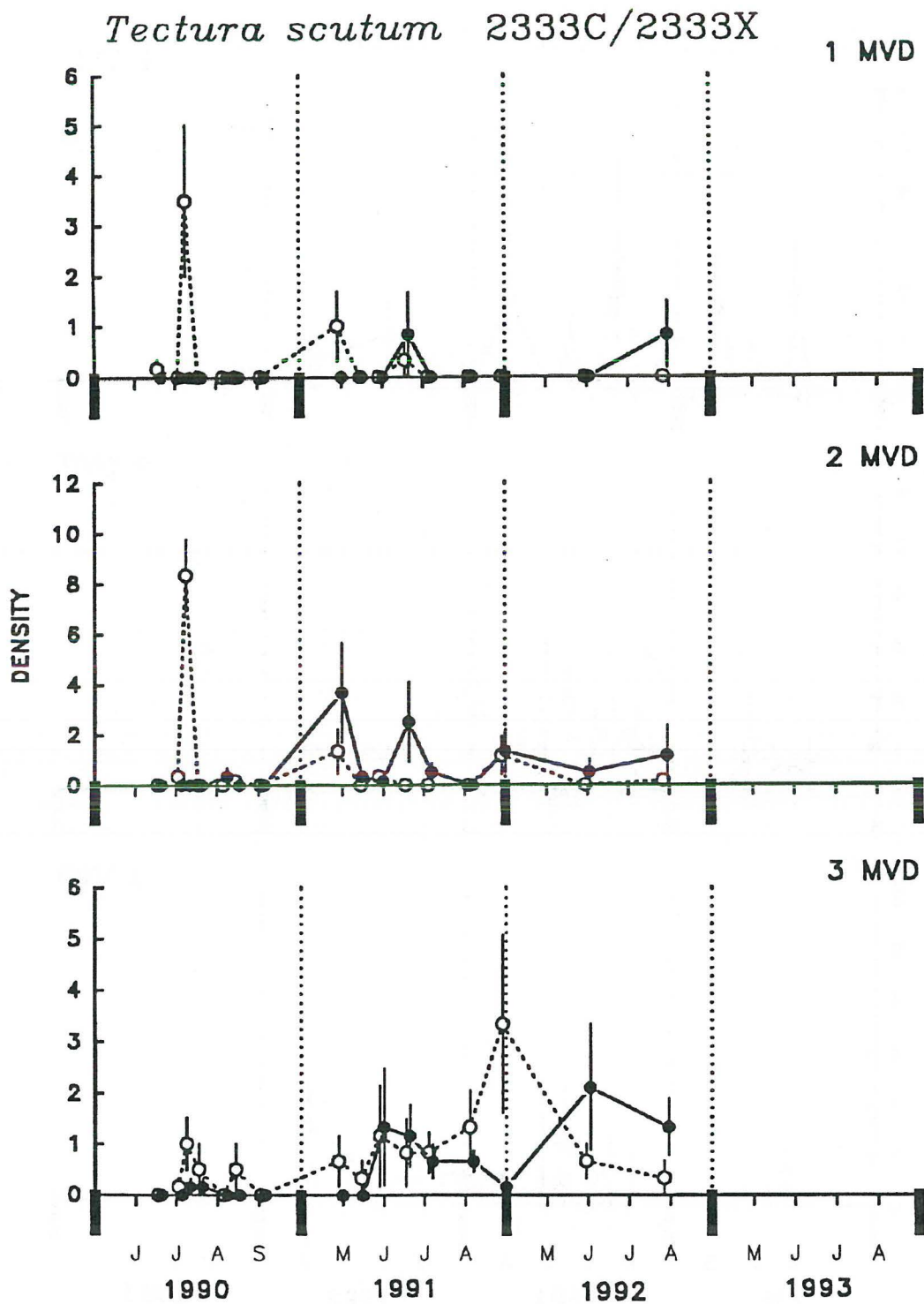

Figure 3.27. Density (No./0.1 m²) of the limpet *Tectura scutum* at site pair 2333C/2333X at each tidal elevation for the 1990 to 1992 seasons. Layout same as Figure 3.3.

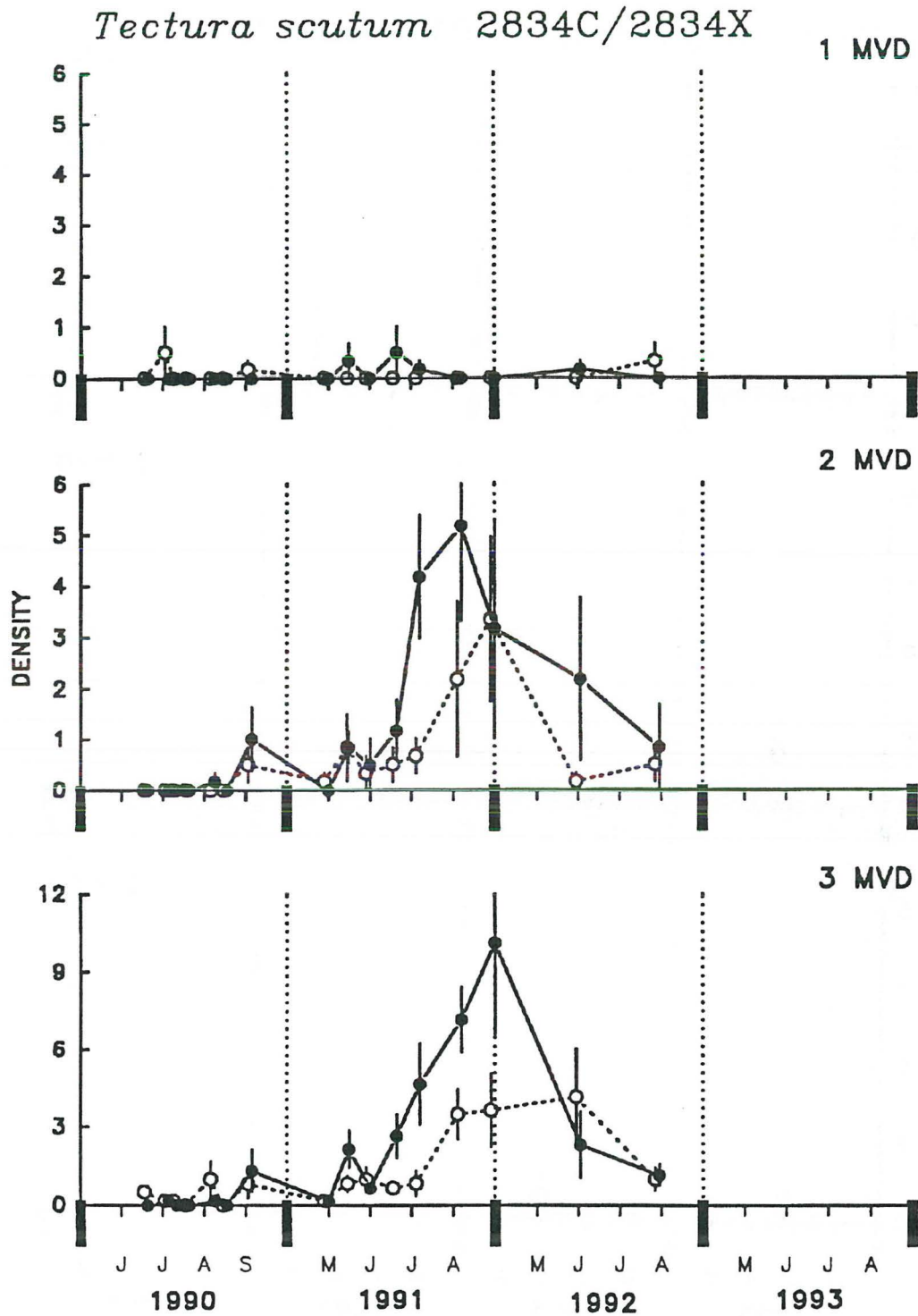

Figure 3.28. Density (No./0.1 m²) of the limpet *Tectura scutum* at site pair 2834C/2834X at each tidal elevation for the 1990 to 1992 seasons. Layout same as Figure 3.3.

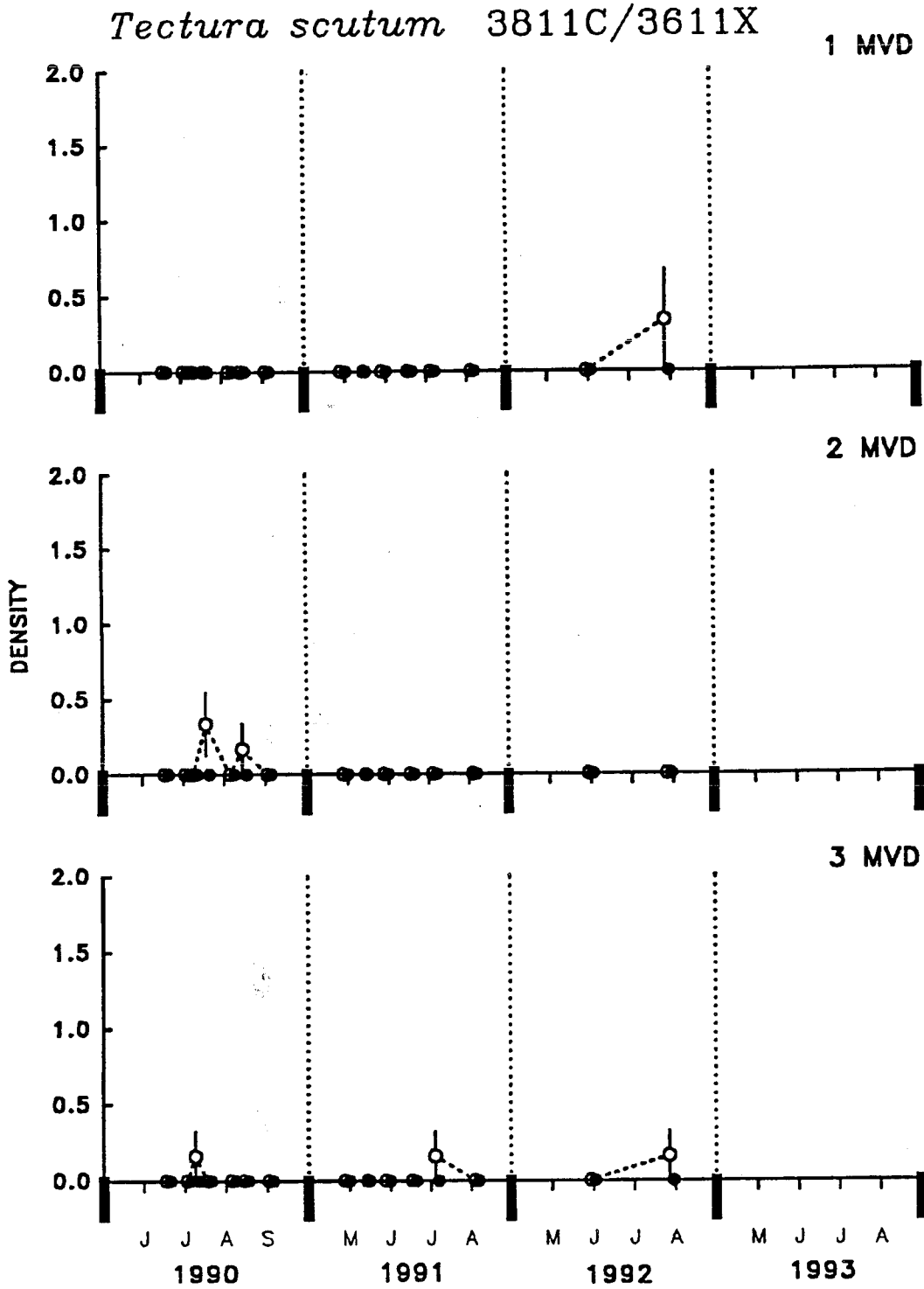

Figure 3.29. Density (No./0.1 m²) of the limpet *Tectura scutum* at site pair 3811C/3611X at each tidal elevation for the 1990 to 1992 seasons. Layout same as Figure 3.3.

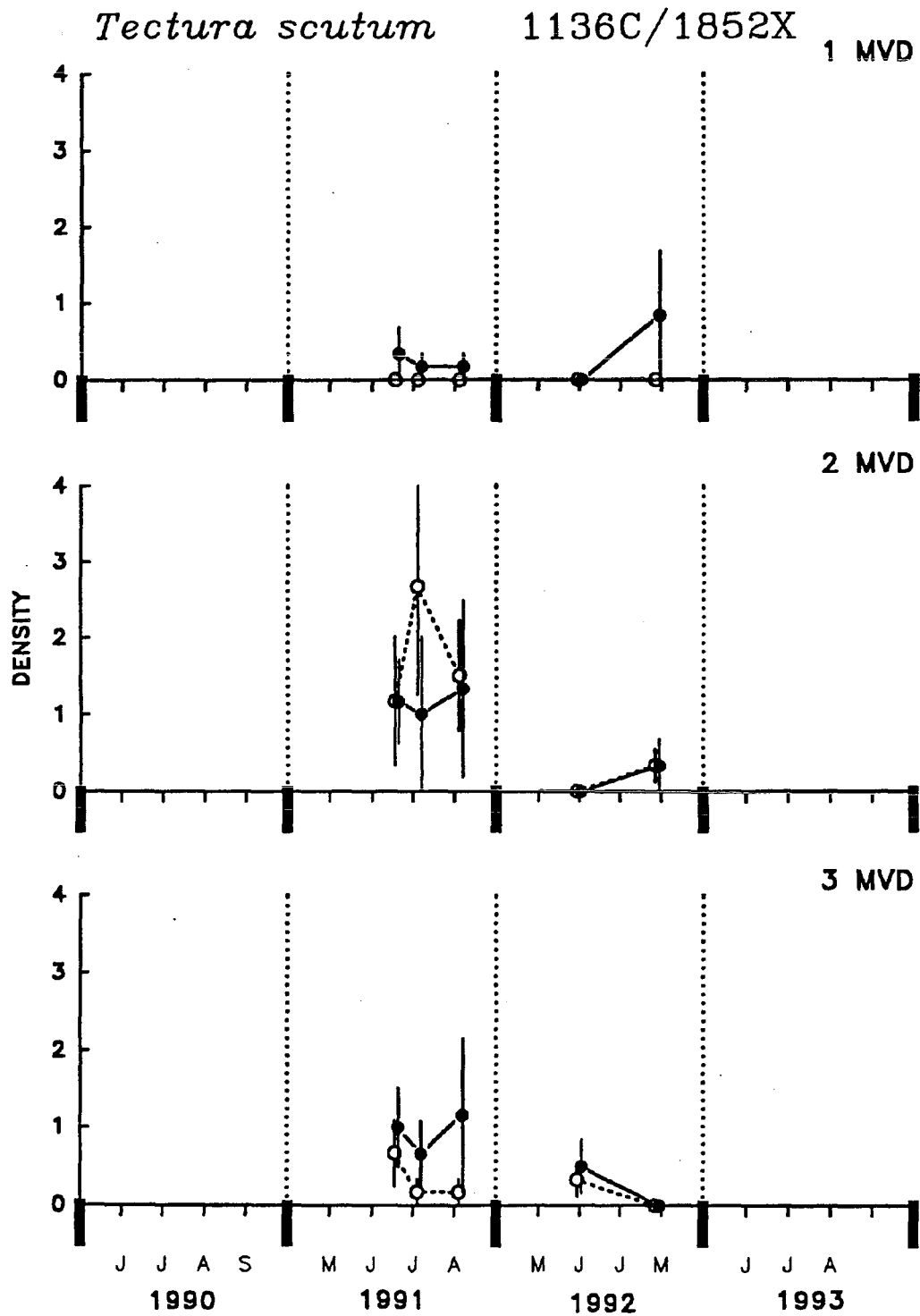

Figure 3.30. Density (No./0.1 m²) of the limpet *Tectura scutum* at site pair 1136C/1852X at each tidal elevation for the 1991 to 1992 seasons. Layout same as Figure 3.3.

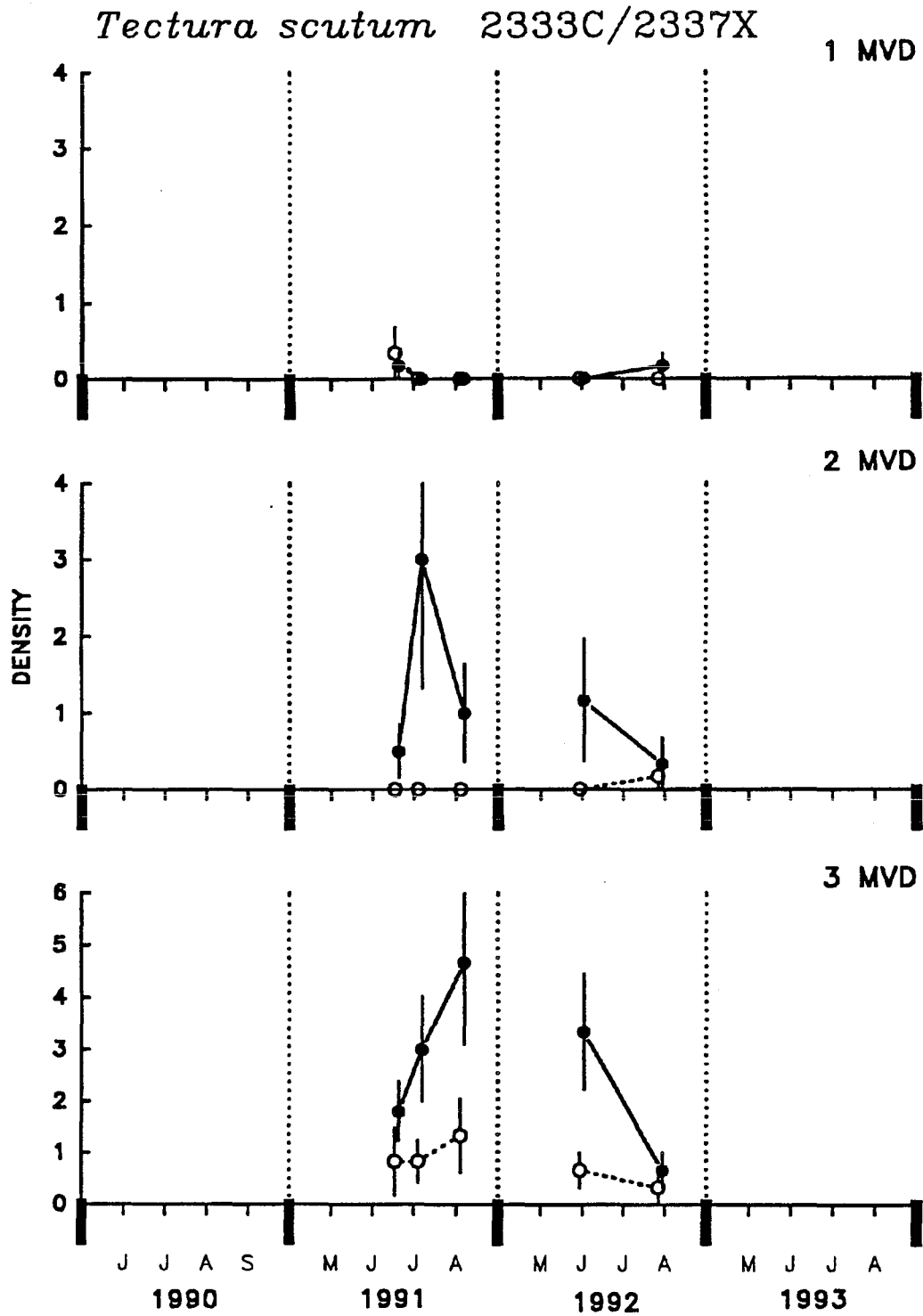

Figure 3.31. Density (No./0.1 m²) of the limpet *Tectura scutum* at site pair 2333C/2337X at each tidal elevation for the 1991 to 1992 seasons. Layout same as Figure 3.3.

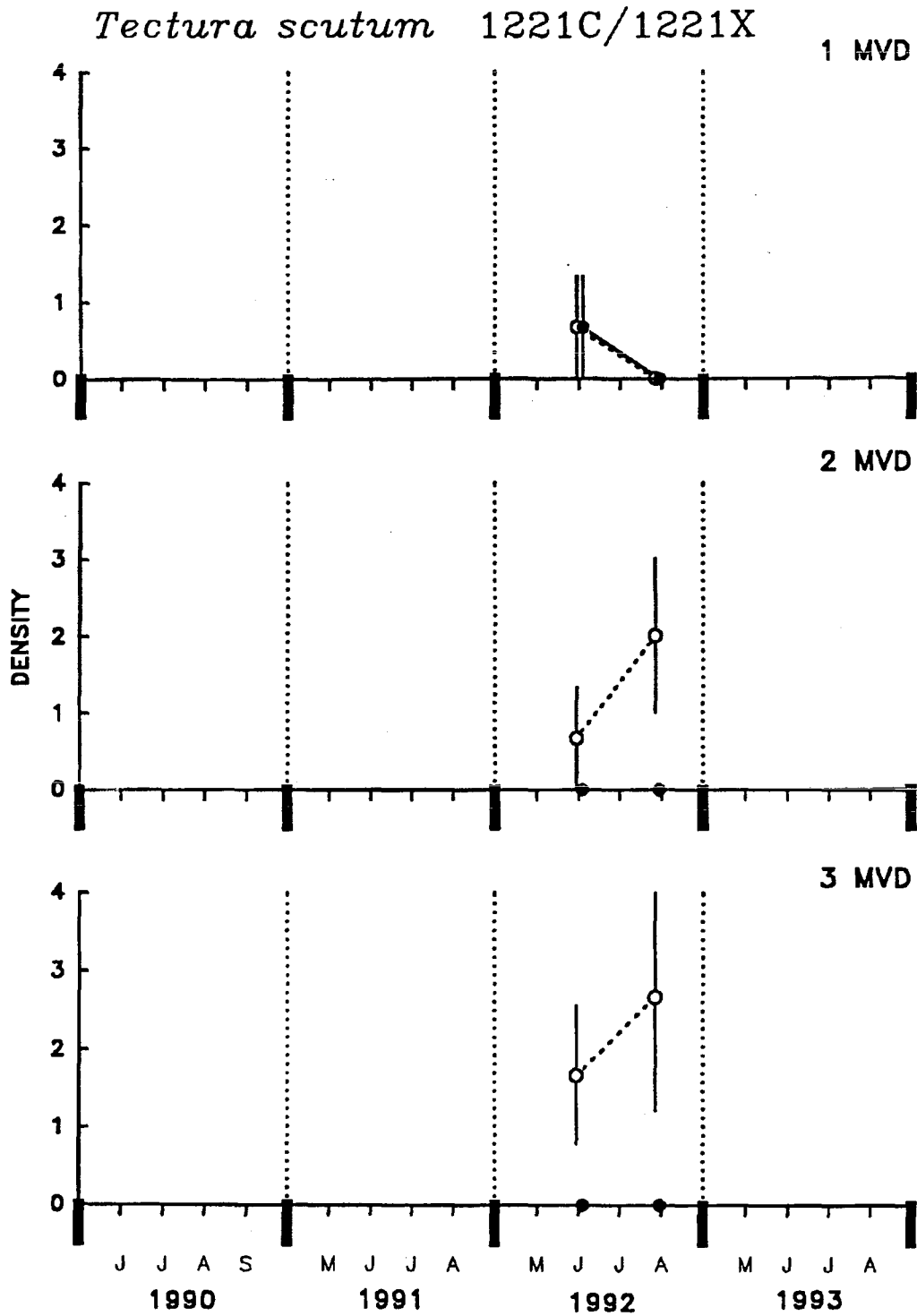

Figure 3.32. Density (No./0.1 m²) of the limpet *Tectura scutum* at site pair 1221C/1221X at each tidal elevation during the 1992 season. Layout same as Figure 3.3.

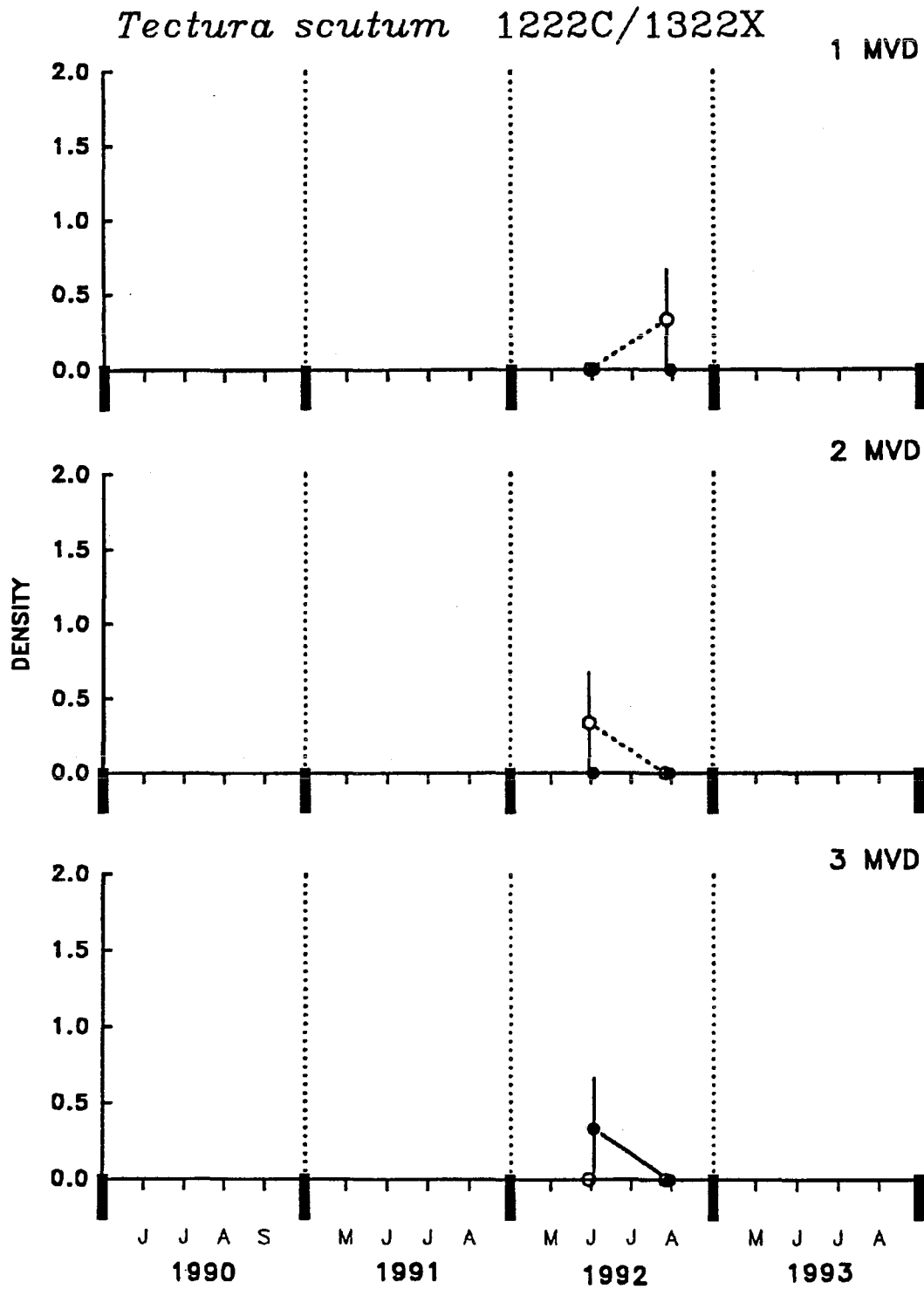

Figure 3.33. Density (No./0.1 m²) of the limpet *Tectura scutum* at site pair 1222C/1322X at each tidal elevation during the 1992 season. Layout same as Figure 3.3.

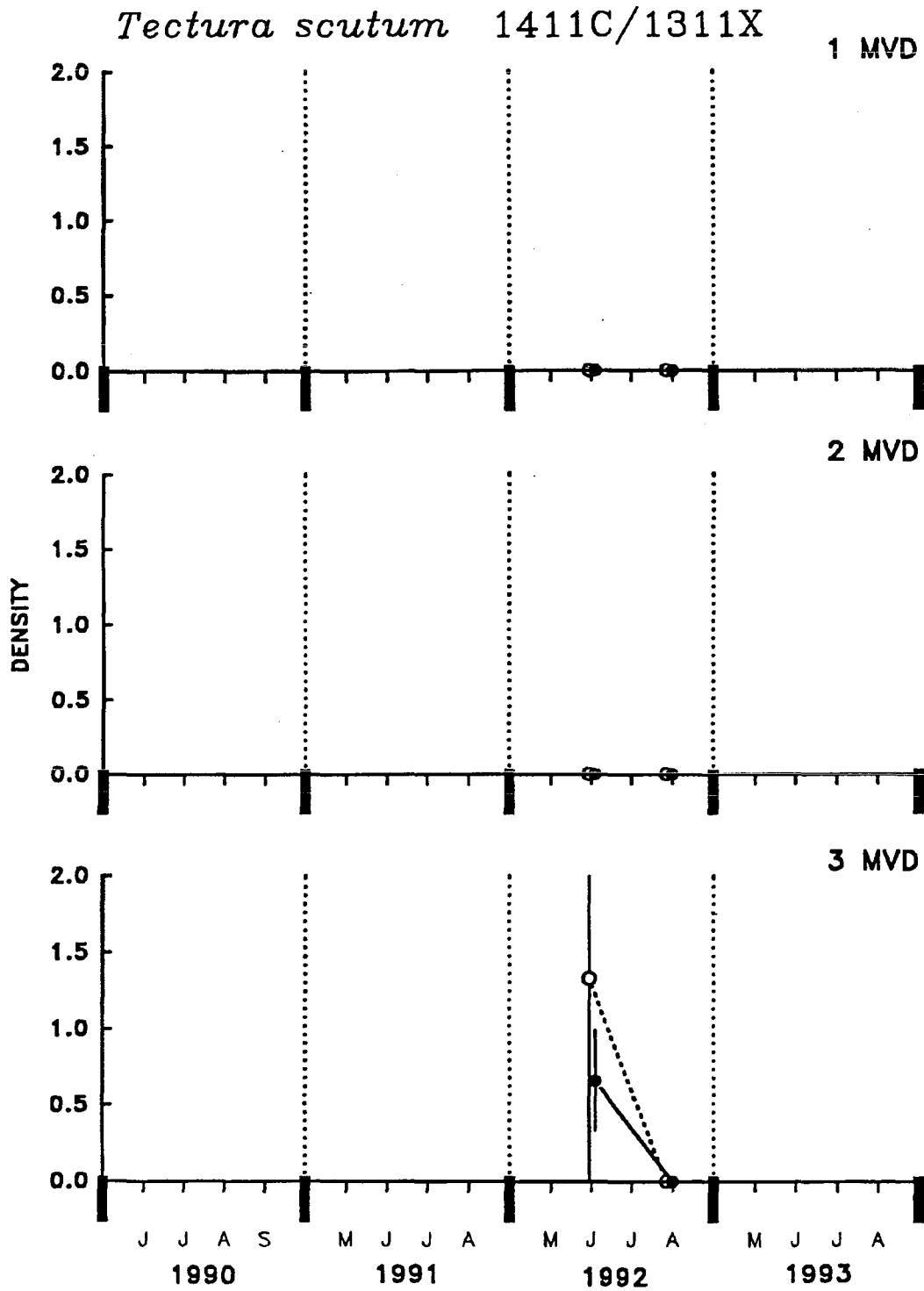

Figure 3.34. Density (No./0.1 m²) of the limpet *Tectura scutum* at site pair 1411C/1311X at each tidal elevation during the 1992 season. Layout same as Figure 3.3.

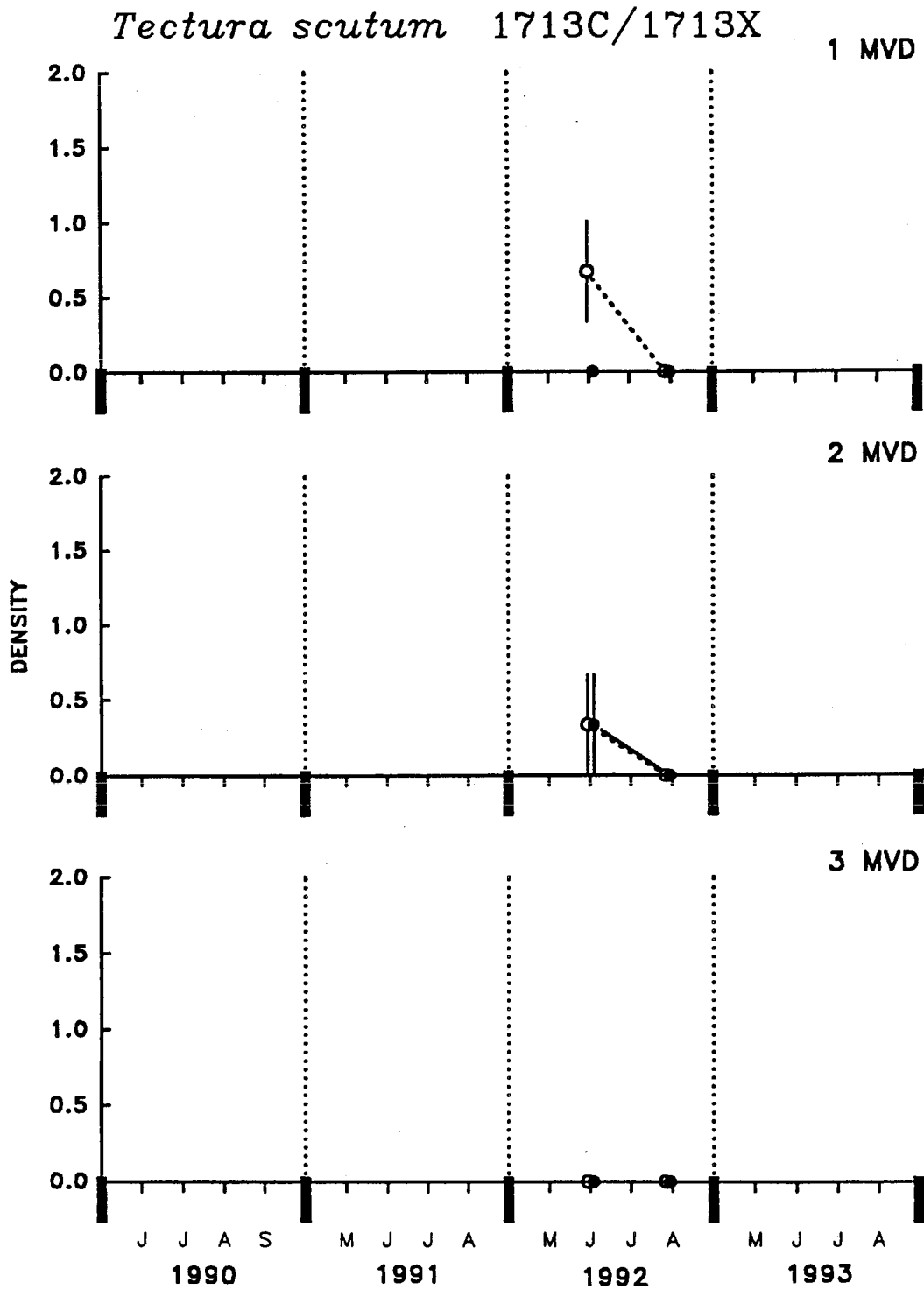

Figure 3.35. Density (No./0.1 m²) of the limpet *Tectura scutum* at site pair 1713C/1713X at each tidal elevation during the 1992 season. Layout same as Figure 3.3.

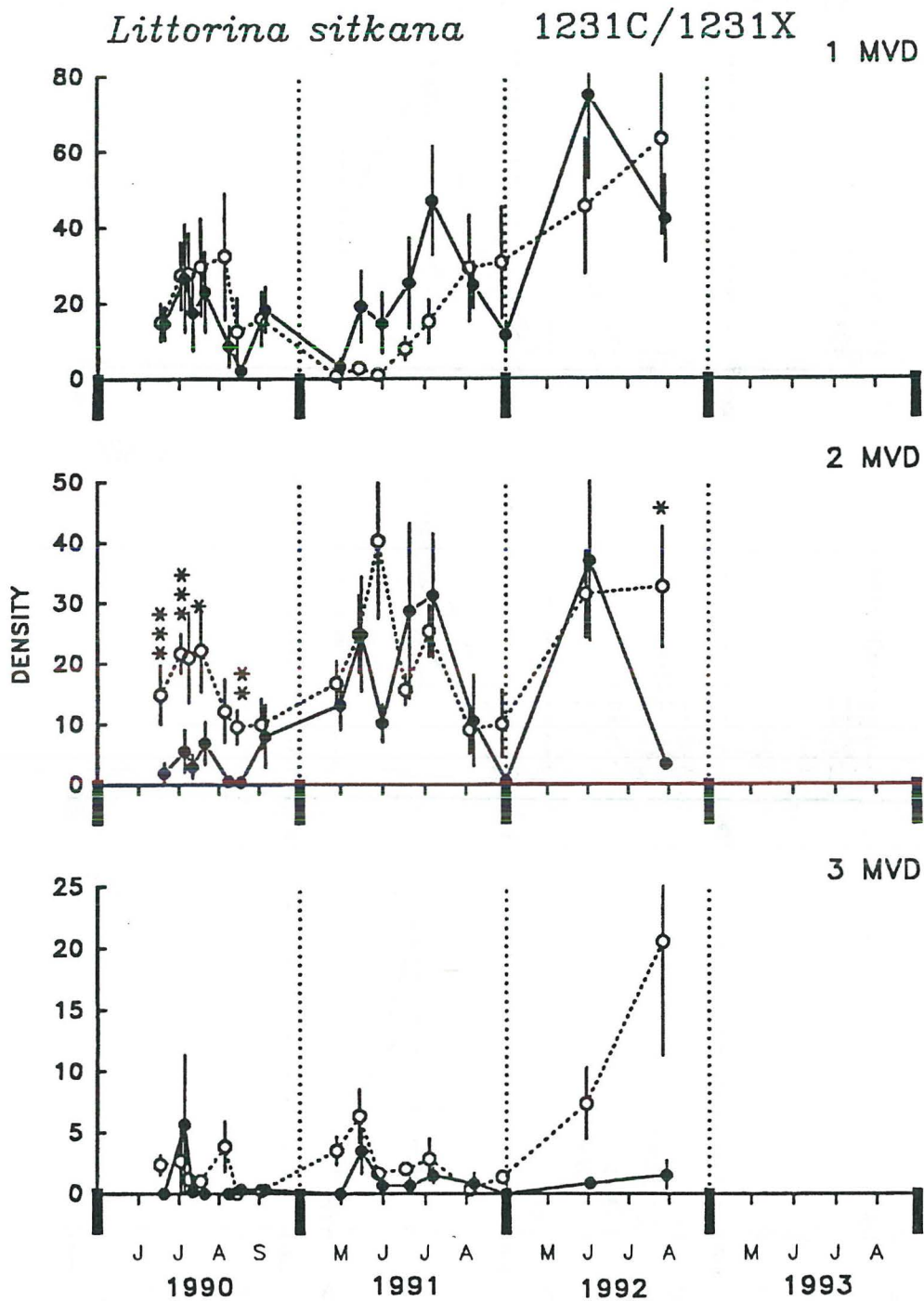

Figure 3.36. Density (No./0.1 m²) of the periwinkle *Littorina sitkana* at site pair 1231C/1231X at each tidal elevation for the 1990 to 1992 seasons. Layout same as Figure 3.3.

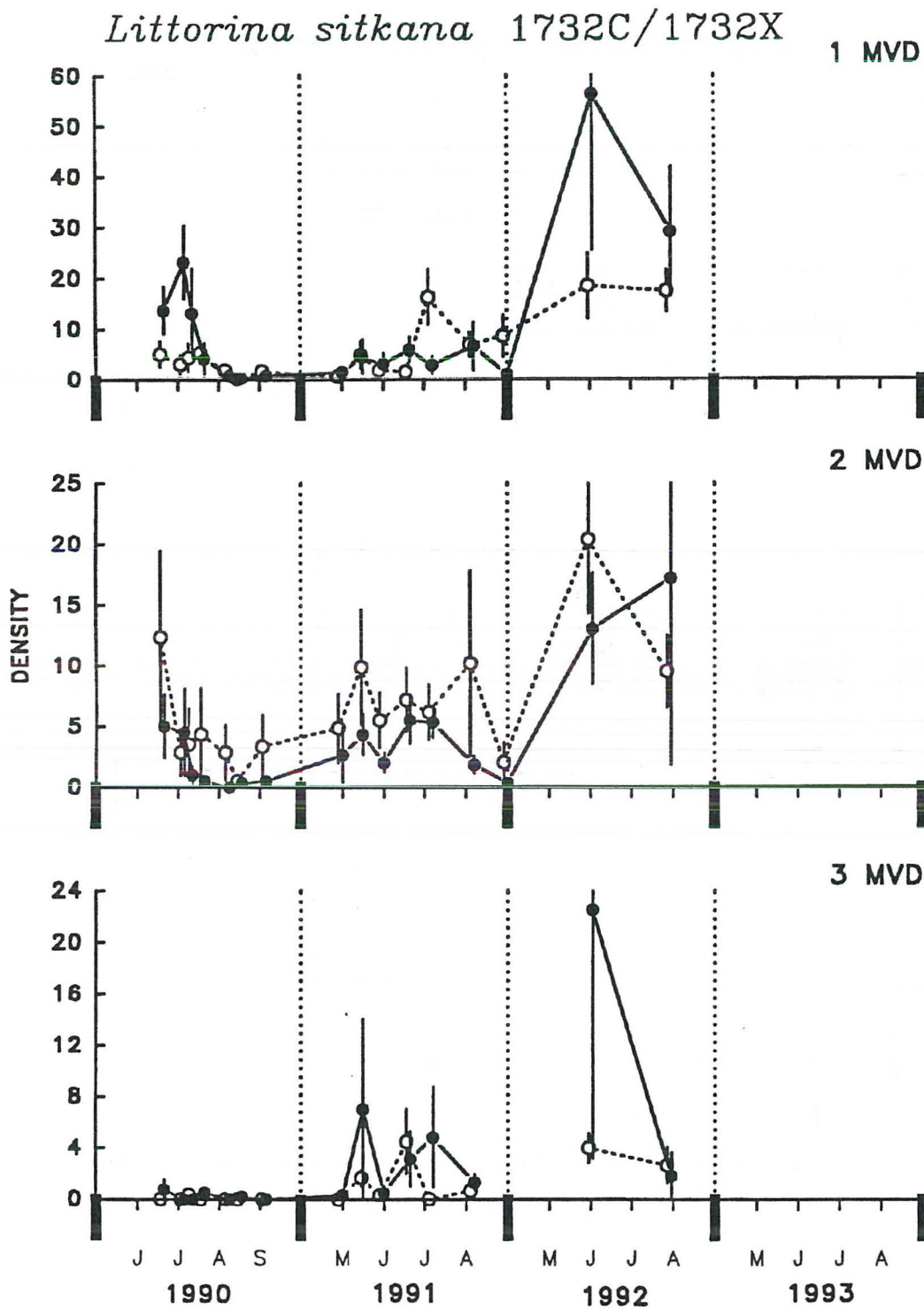

Figure 3.37. Density (No./0.1 m²) of the periwinkle *Littorina sitkana* at site pair 1732C/1732X at each tidal elevation for the 1990 to 1992 seasons. Layout same as Figure 3.3.

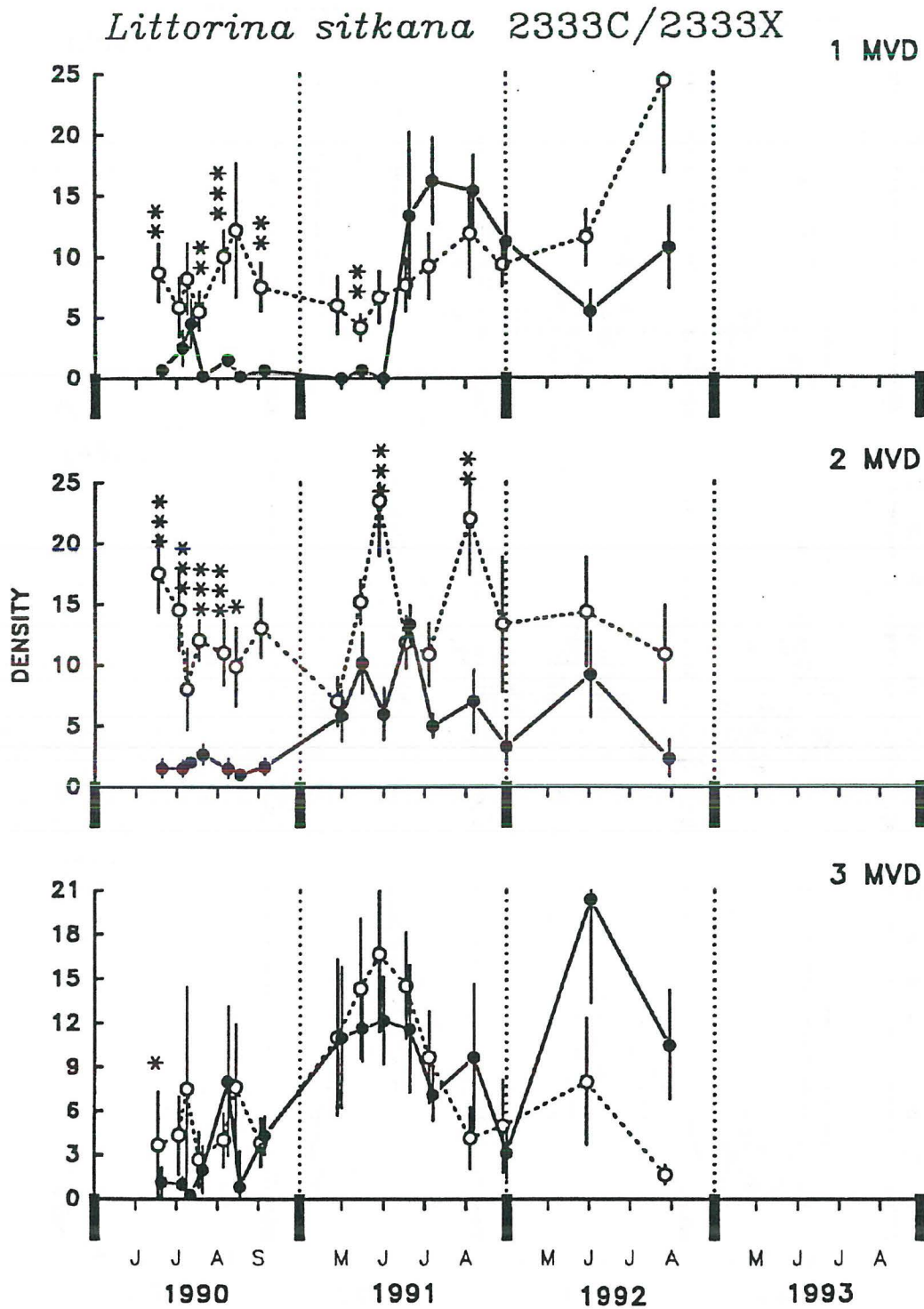

Figure 3.38. Density (No./0.1 m²) of the periwinkle *Littorina sitkana* at site pair 2333C/2333X at each tidal elevation for the 1990 to 1992 seasons. Layout same as Figure 3.3.

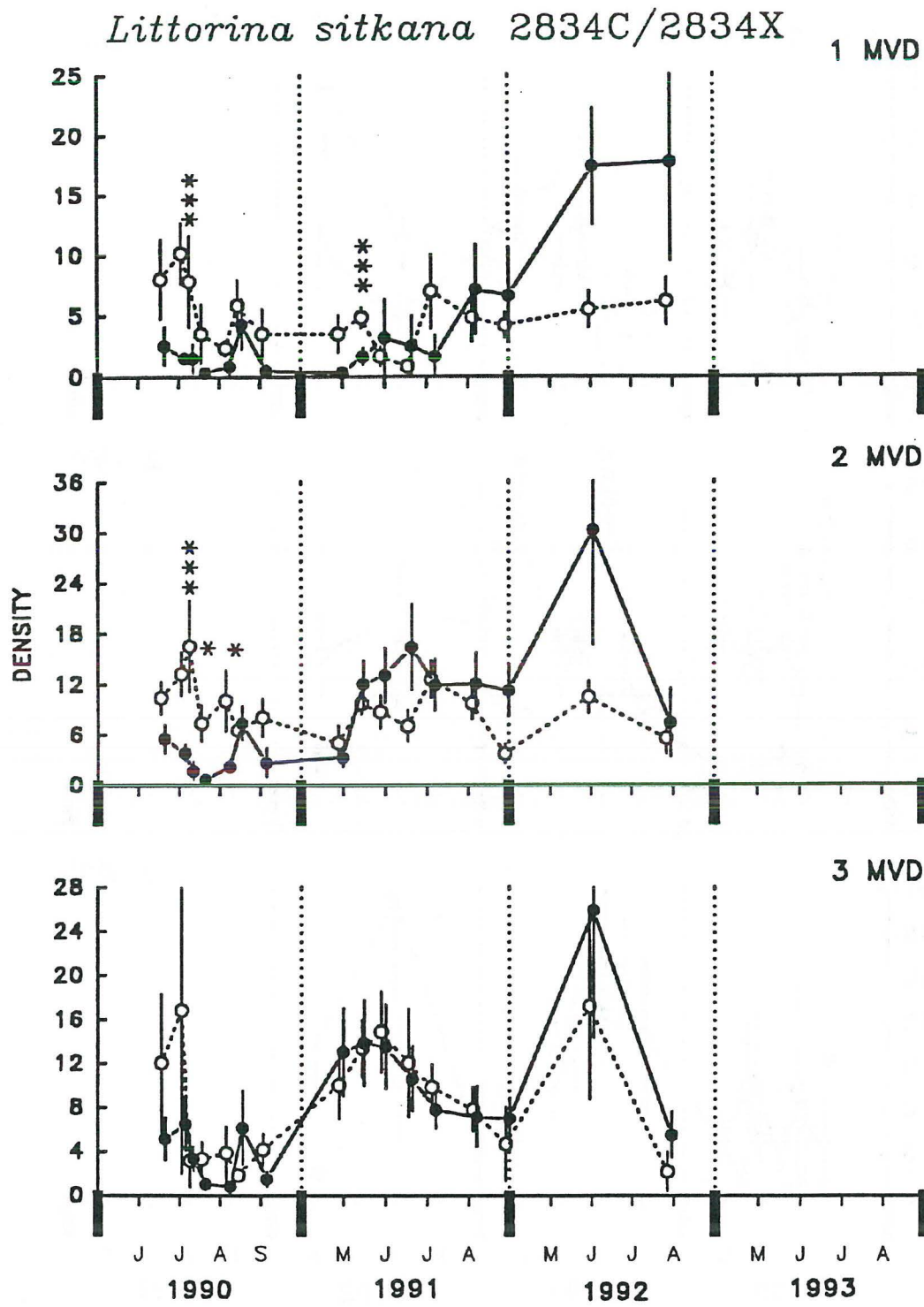

Figure 3.39. Density (No./0.1 m²) of the periwinkle *Littorina sitkana* at site pair 2834C/2834X at each tidal elevation for the 1990 to 1992 seasons. Layout same as Figure 3.3.

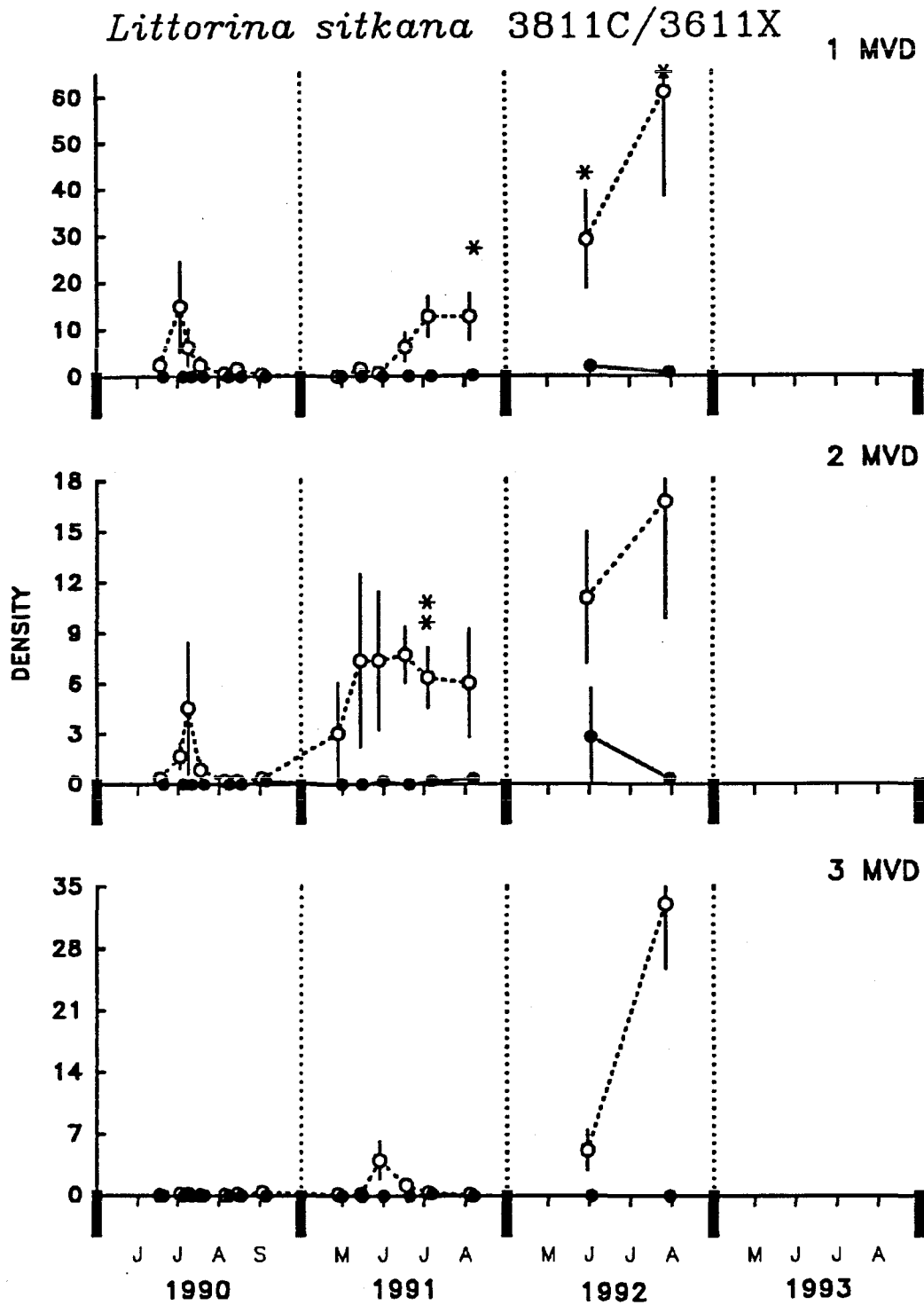

Figure 3.40. Density (No./0.1 m²) of the periwinkle *Littorina sitkana* at site pair 3811C/3611X at each tidal elevation for the 1990 to 1992 seasons. Layout same as Figure 3.3.

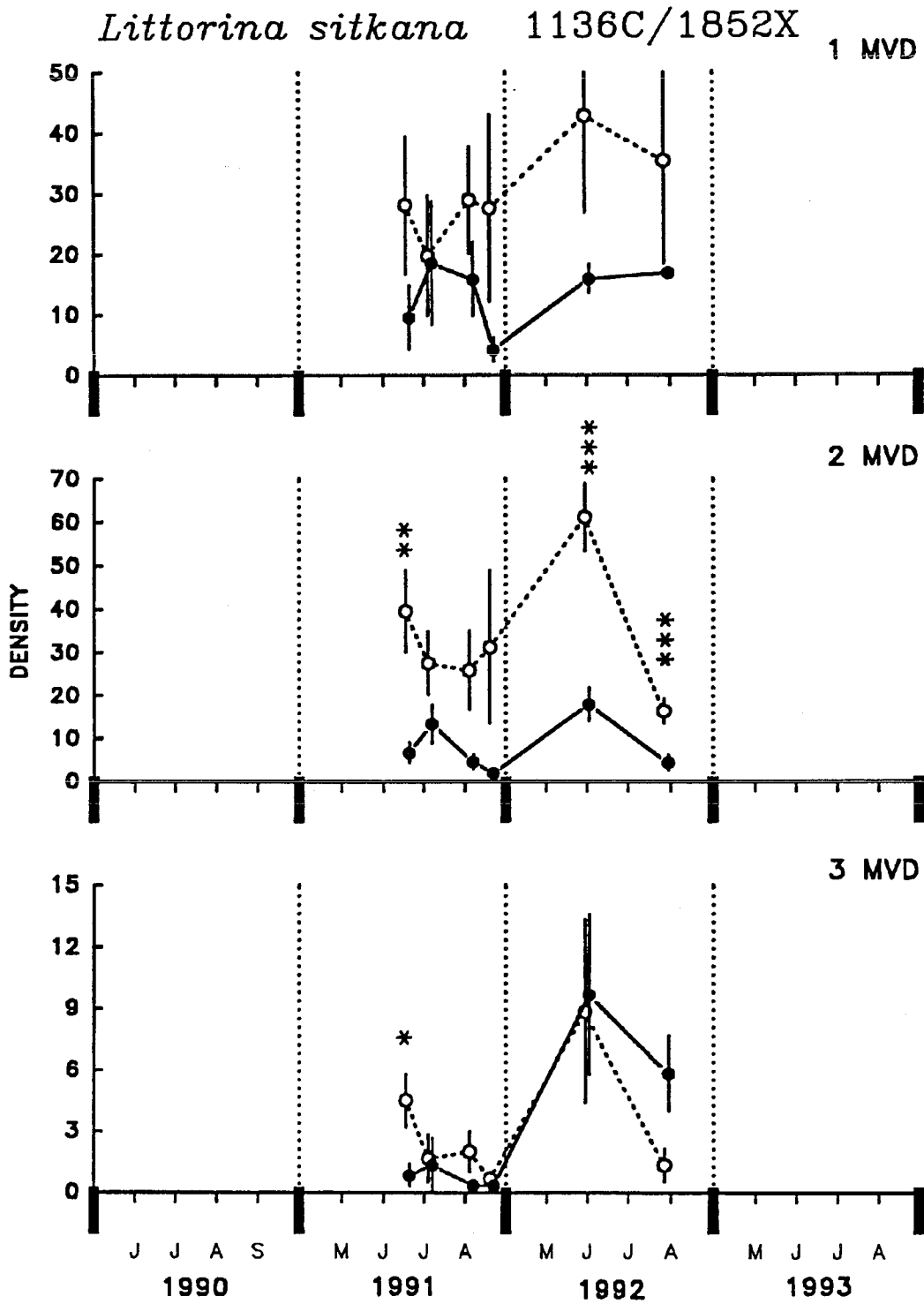

Figure 3.41. Density (No./0.1 m²) of the periwinkle *Littorina sitkana* at site pair 1136C/1852X at each tidal elevation for the 1991 to 1992 seasons. Layout same as Figure 3.3.

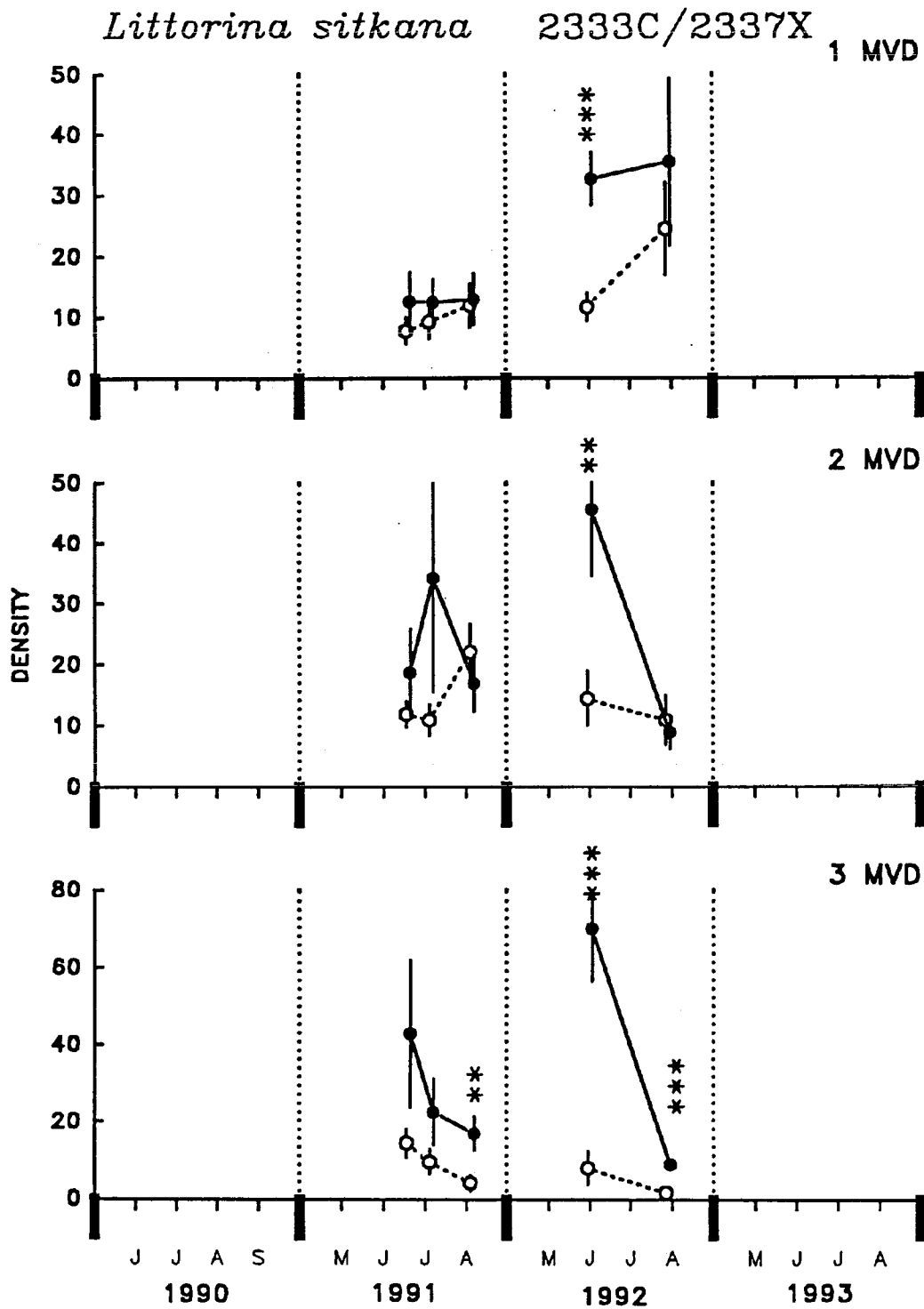

Figure 3.42. Density (No./0.1 m²) of the periwinkle *Littorina sitkana* at site pair 2333C/2337X at each tidal elevation for the 1991 to 1992 seasons. Layout same as Figure 3.3.

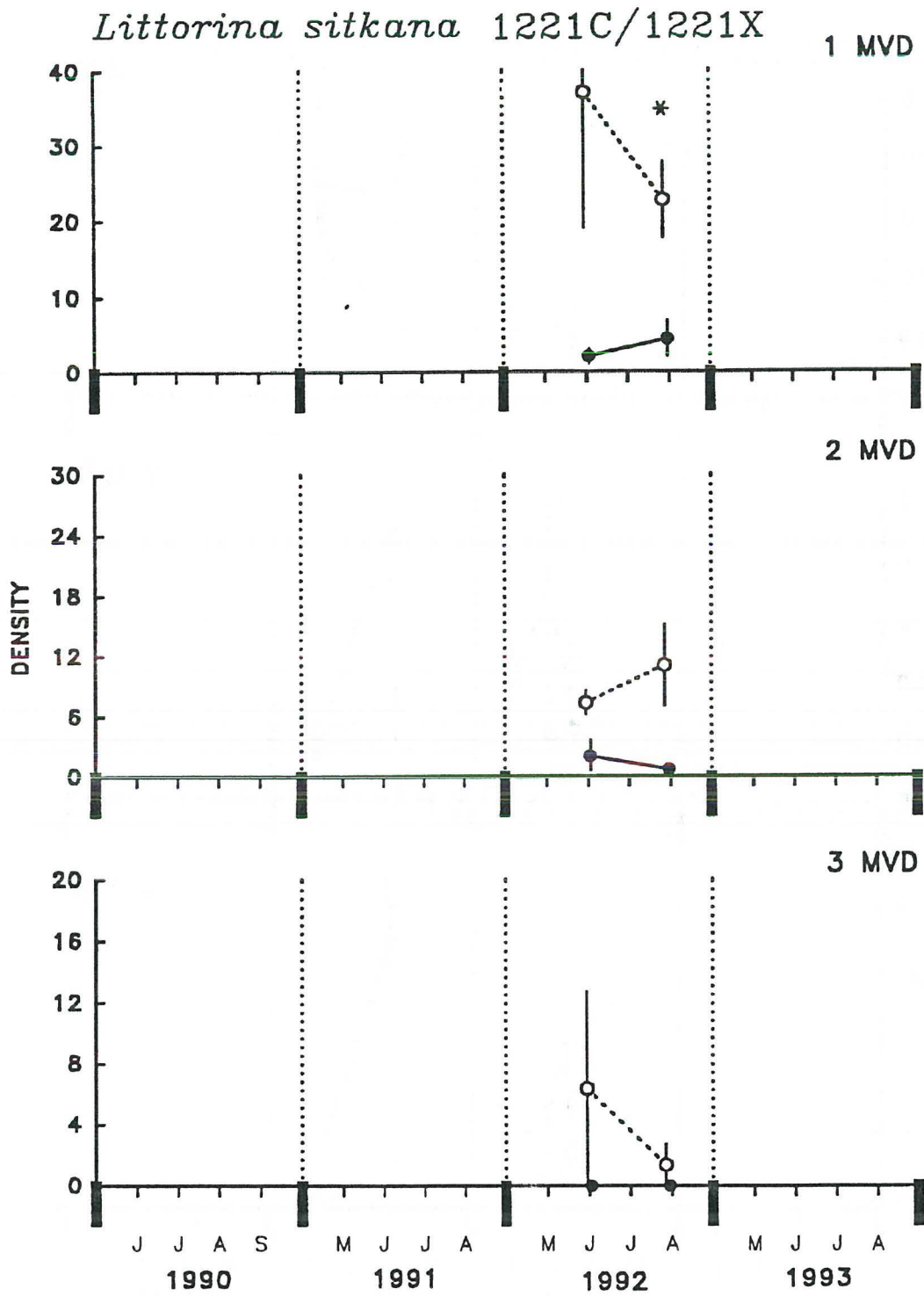

Figure 3.43. Density (No./0.1 m²) of the periwinkle *Littorina sitkana* at site pair 1221C/1221X at each tidal elevation during the 1992 season. Layout same as Figure 3.3.

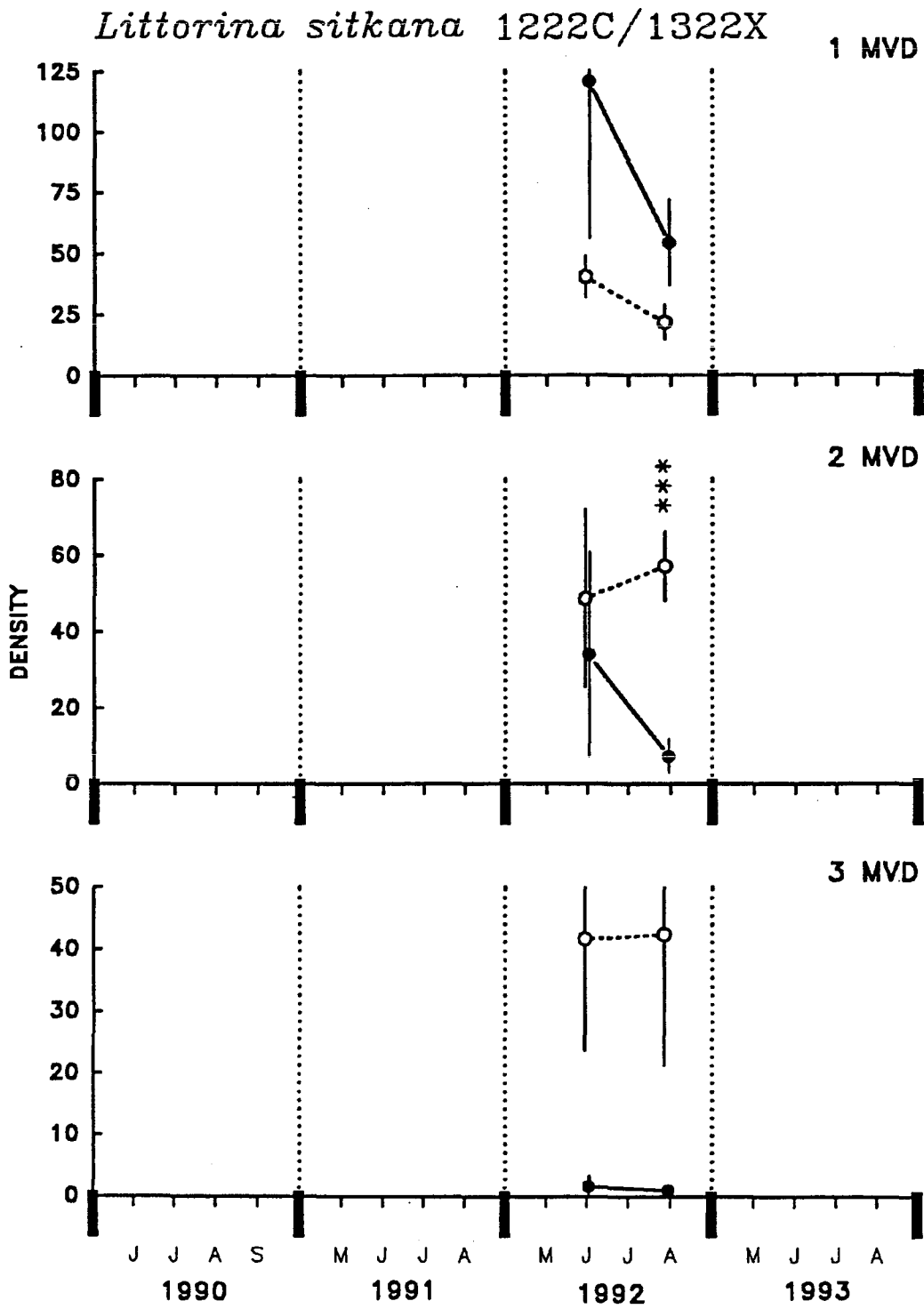

Figure 3.44. Density (No./0.1 m²) of the periwinkle *Littorina sitkana* at site pair 1222C/1322X at each tidal elevation during the 1992 season. Layout same as Figure 3.3.

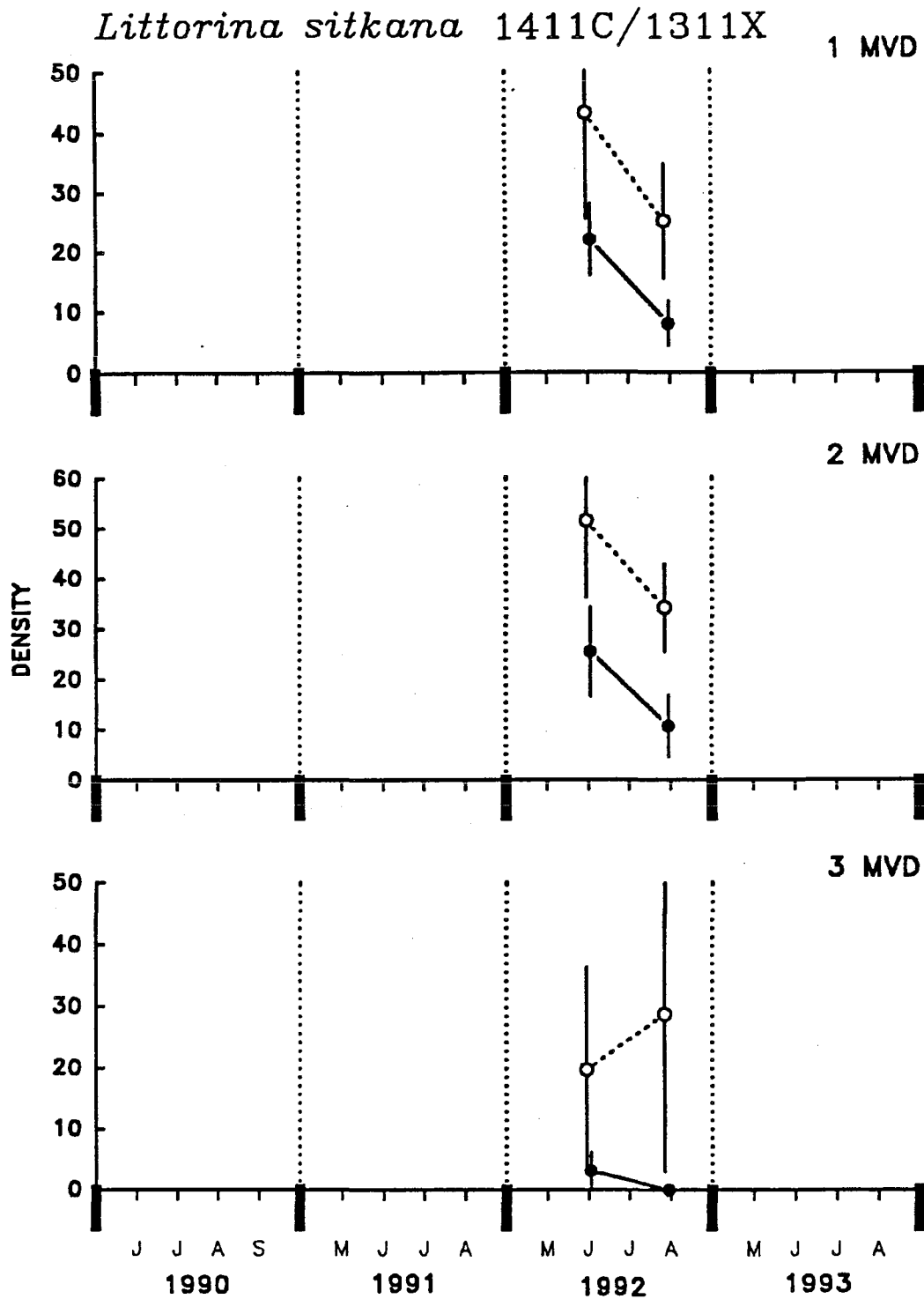

Figure 3.45. Density (No./0.1 m²) of the periwinkle *Littorina sitkana* at site pair 1411C/1311X at each tidal elevation during the 1992 season. Layout same as Figure 3.3.

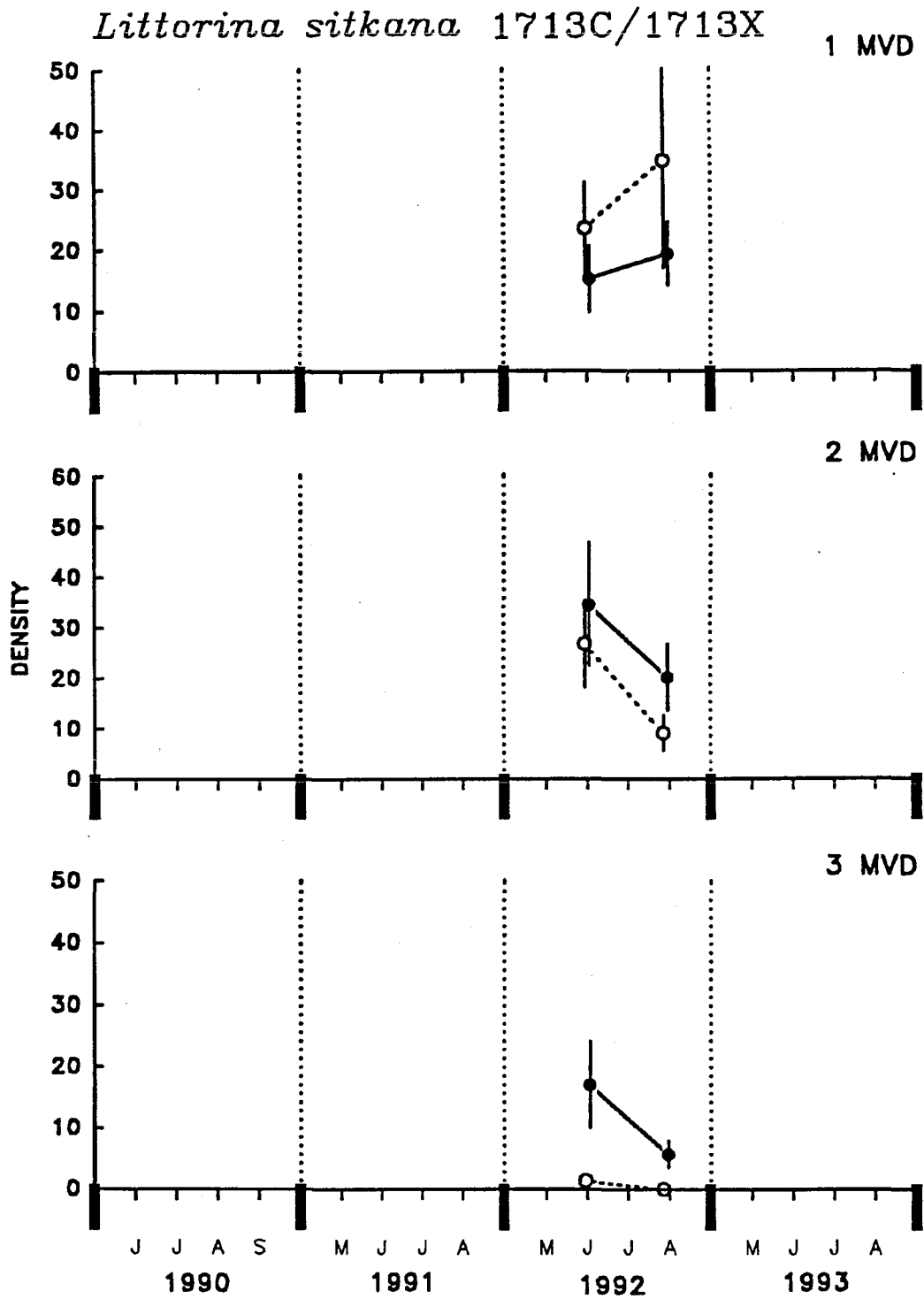

Figure 3.46. Density (No./0.1 m²) of the periwinkle *Littorina sitkana* at site pair 1713C/1713X at each tidal elevation during the 1992 season. Layout same as Figure 3.3.

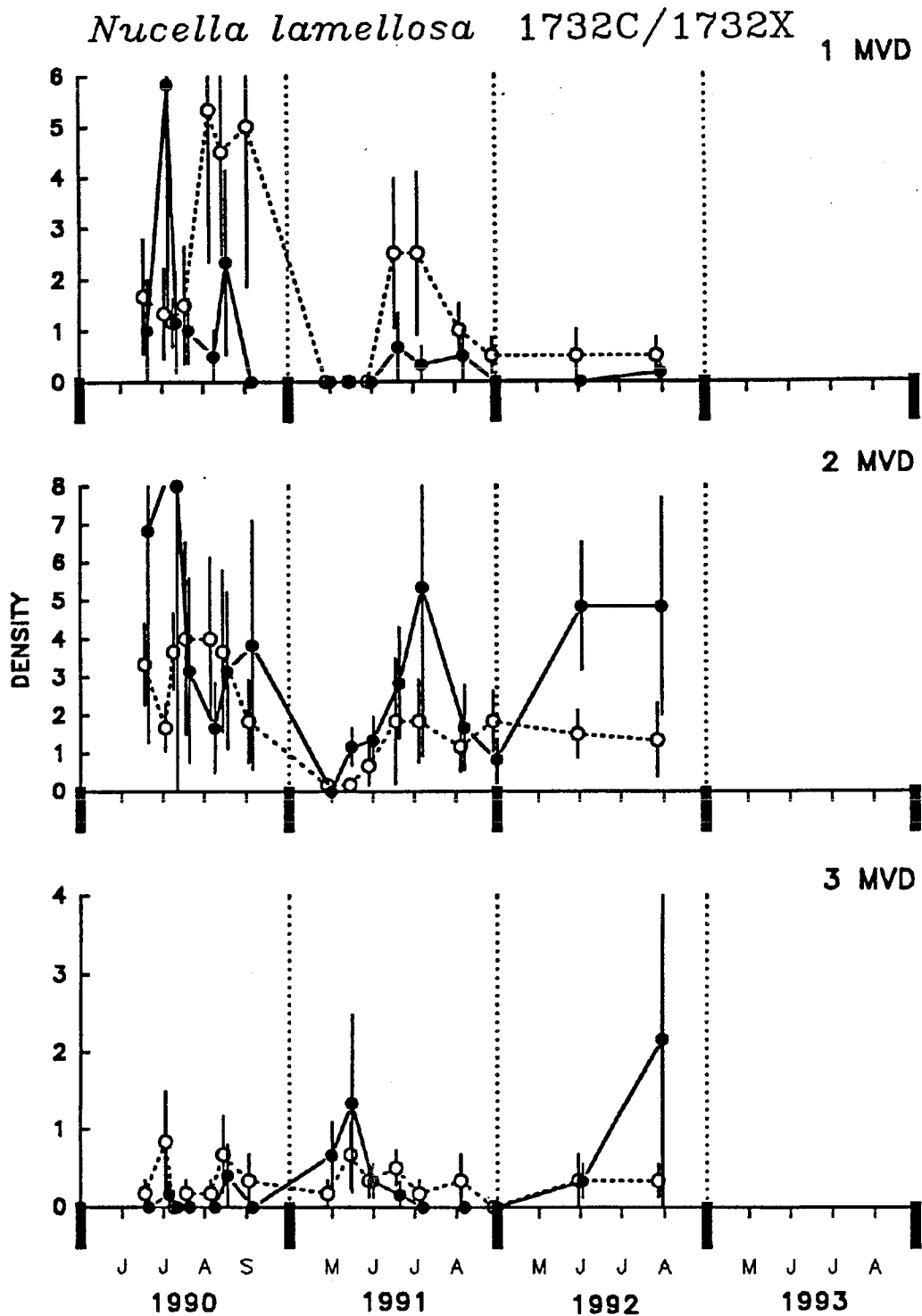

Figure 3.47. Density (No./0.1m²) of dog whelk *Nucella lamellosa* at site pair 1732C/1732X at each tidal elevation during the 1992 season. Layout same as Figure 3.3.

Barnacle juveniles - uncaged plots

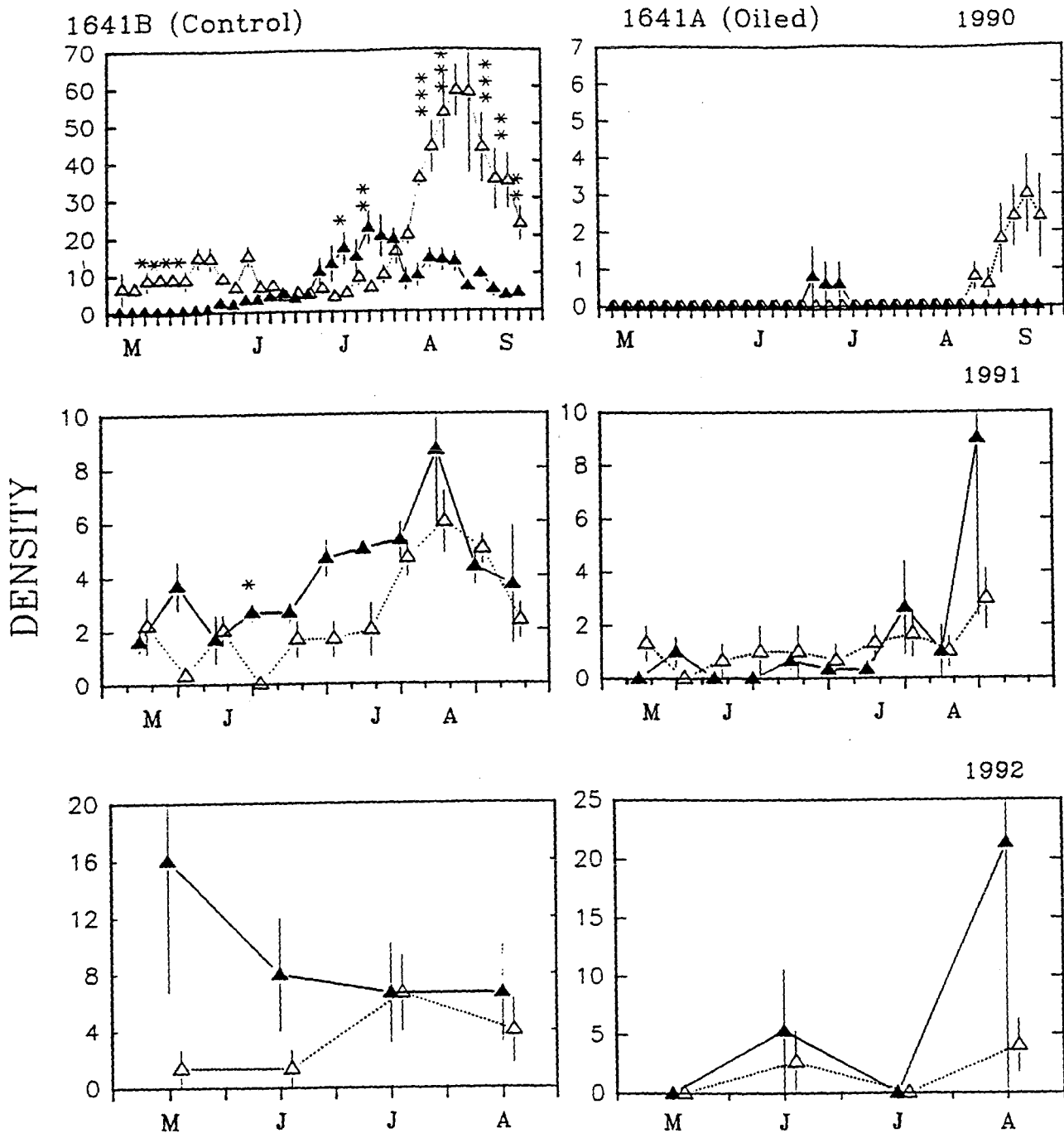

Figure 3.48. Density (No./0.01 m²) of barnacle recruits that settled on uncaged, tarred and scraped vertical rock faces at site pair 1641 during spring-fall 1990-1992 (top to bottom). Control and oiled plots are represented by solid triangles with sample dates connected by a solid line. The scraped plots are represented by open triangles connected by dotted lines. Letters on X-axis are months from May to September. Note scale differences on vertical axis. Number of samplings: 1990 - 32 between 5/30 and 9/21; 1991 - 10 to 11 between 4/30 and 8/26; 1992 - 4 between 5/31 and 8/27. All plots were located 0.5 m below mean high high water. N=5 for 1990. N=3 for 1991 and 1992. Error bars represent plus and minus one standard error of the mean. Statistical significance from paired t-Tests: * = p ≤ 0.05, ** = p ≤ 0.025, *** = p ≤ 0.01.

Barnacle juveniles - uncaged plots

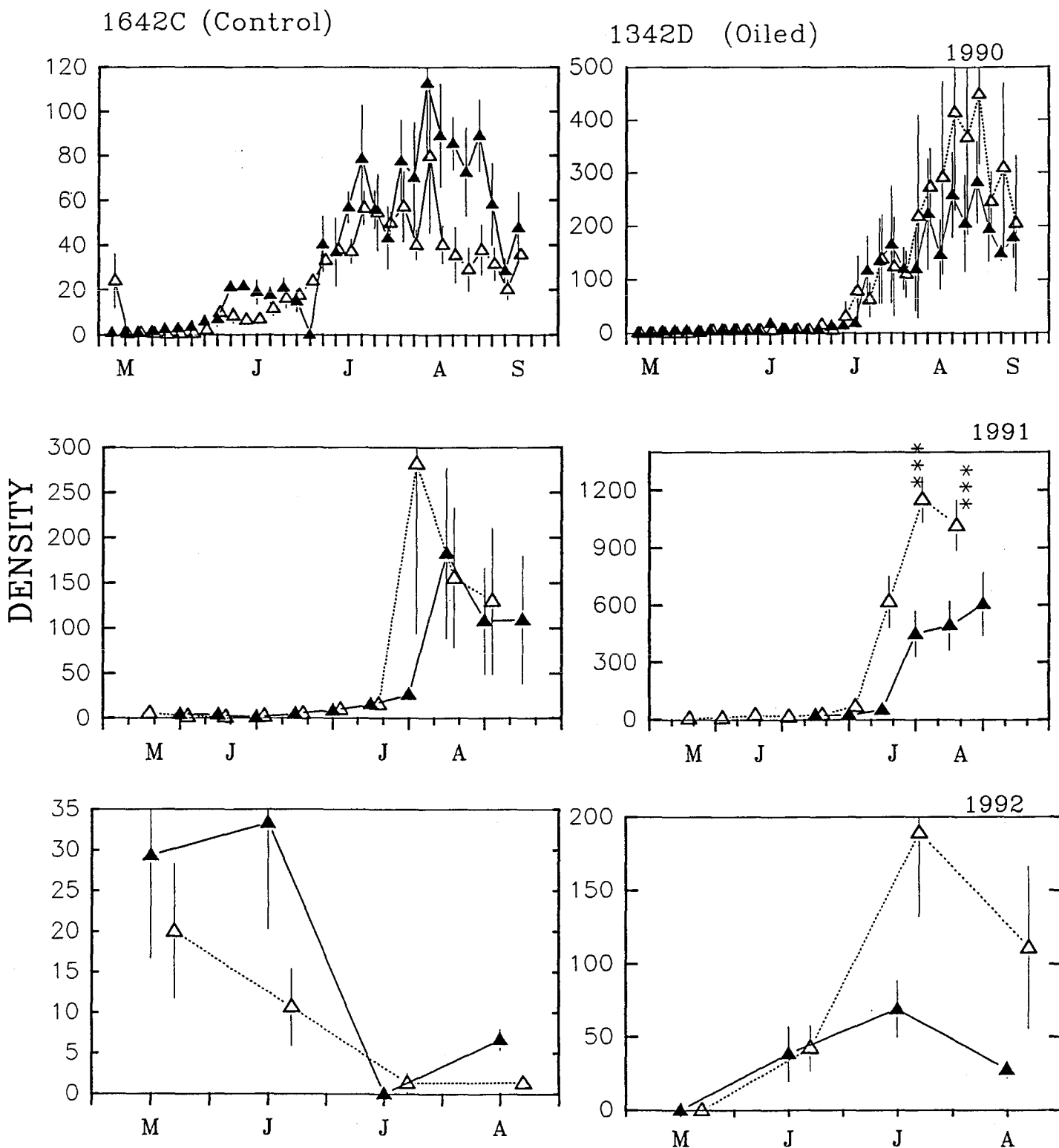

Figure 3.49. Density (No./0.01 m²) of barnacle recruits that settled on uncaged, tarred and scraped vertical rock faces at site pair 1642 during spring-fall 1990-1992 (top to bottom). N=3 for all years. Layout same as Figure 3.48.

Barnacle juveniles – uncaged plots

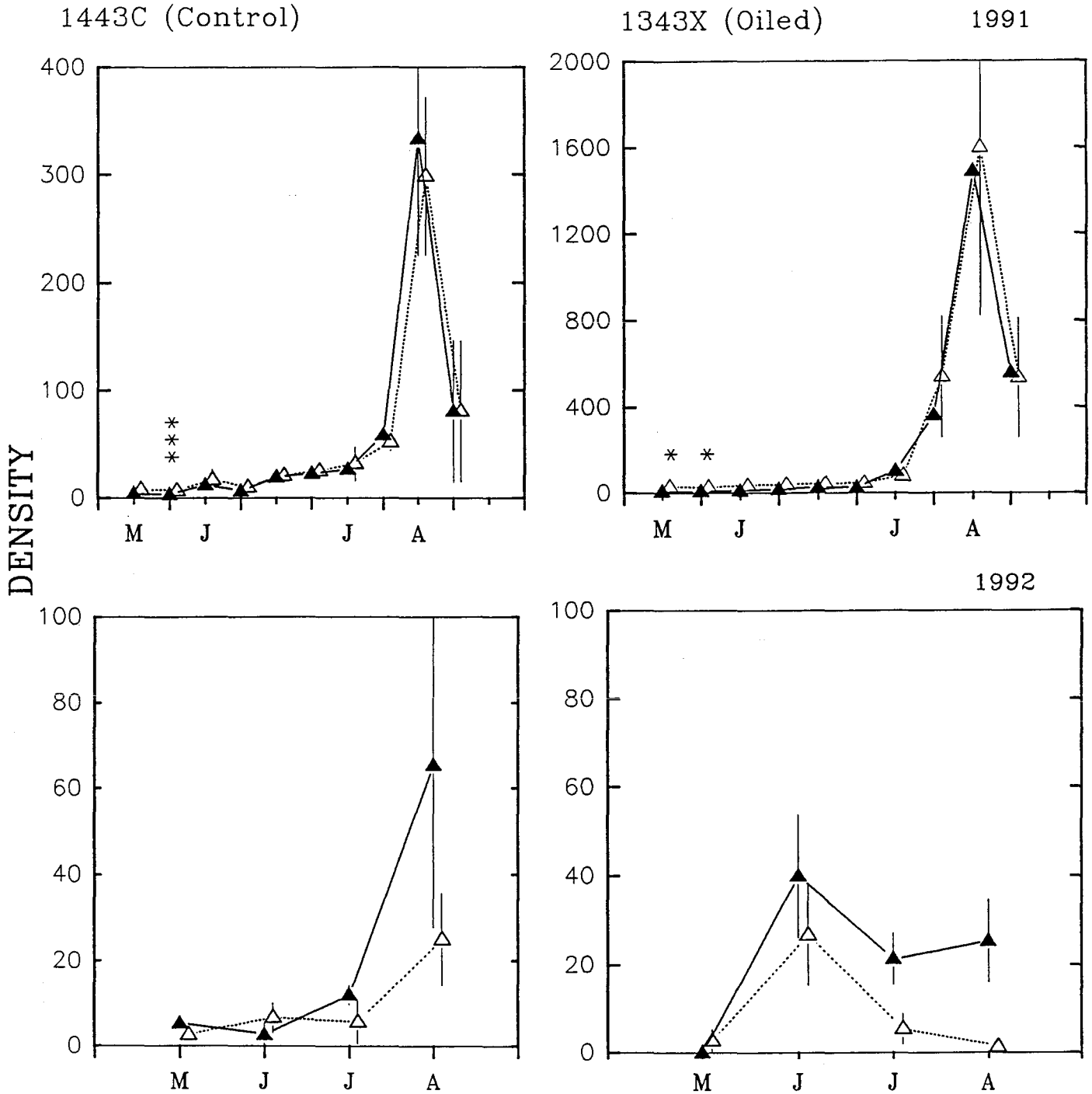

Figure 3.50. Density (No./0.01 m²) of barnacle recruits that settled on uncaged, tarred and scraped vertical rock faces at site pair 1443 during spring-fall 1991-1992. Layout same as Figure 3.48. N=3.

Barnacle juveniles – uncaged plots

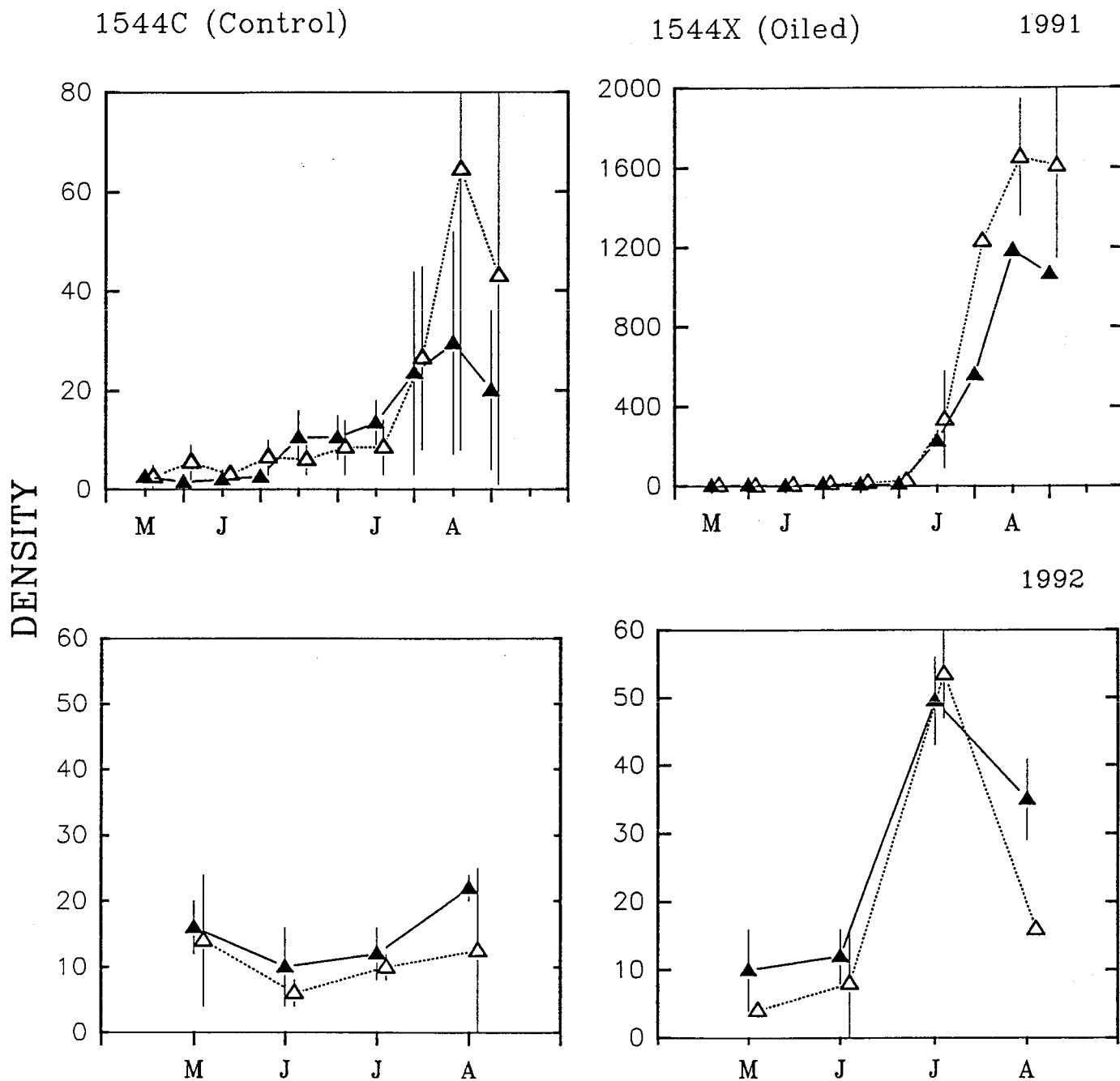

Figure 3.51. Density (No./0.01 m²) of barnacle recruits that settled on uncaged, tarred and scraped vertical rock faces at site pair 1544 during spring-fall 1991-1992. Layout same as Figure 3.48. N=2.

Barnacle juveniles – uncaged plots

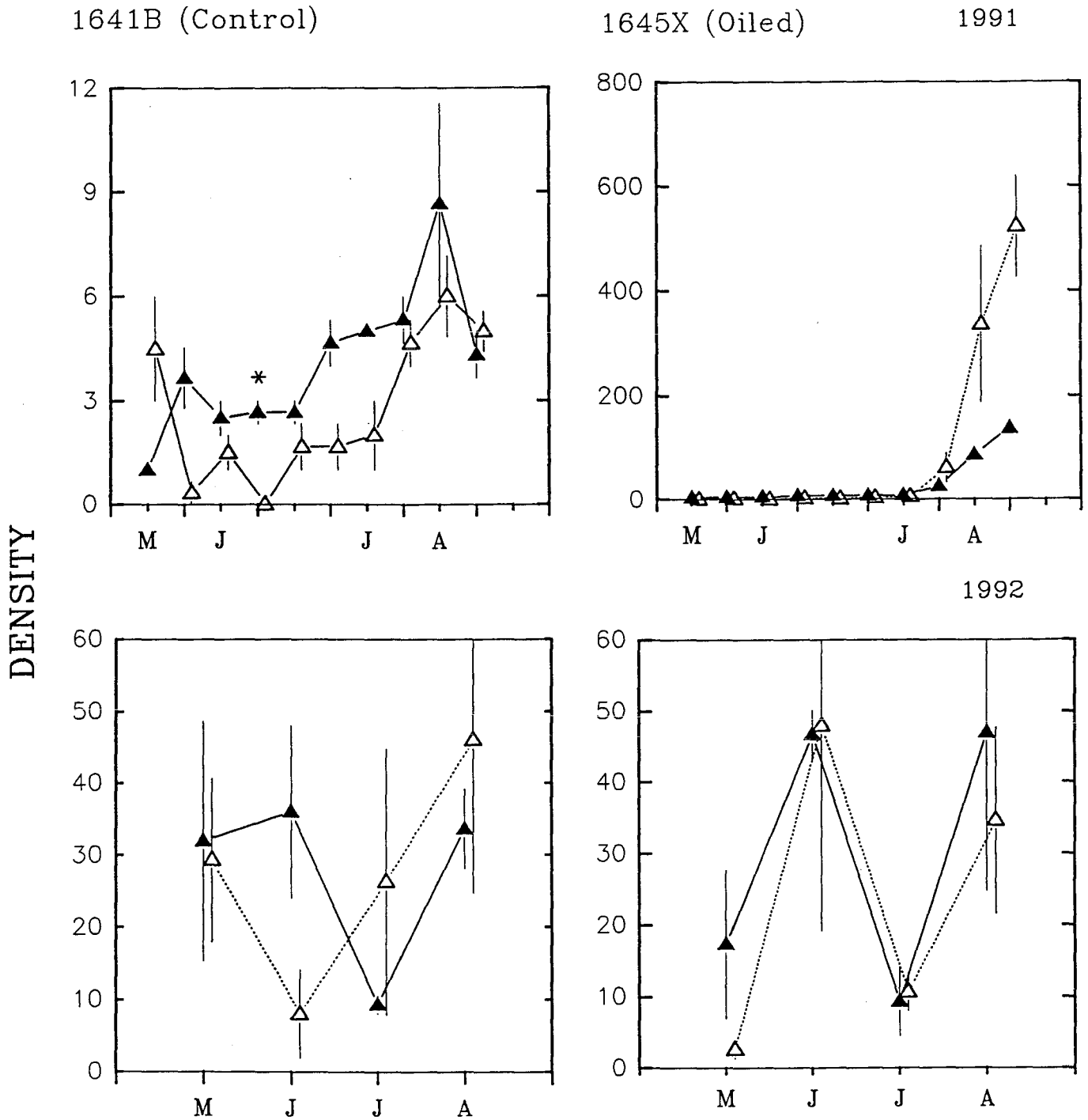

Figure 3.52. Density (No./0.01 m²) of barnacle recruits that settled on uncaged, tarred and scraped vertical rock faces at site pair 1645X during spring-fall 1991-1992. Site 1641B serves as the control match for this pair. Layout same as Figure 3.48. N=3.

Barnacle juveniles – uncaged plots

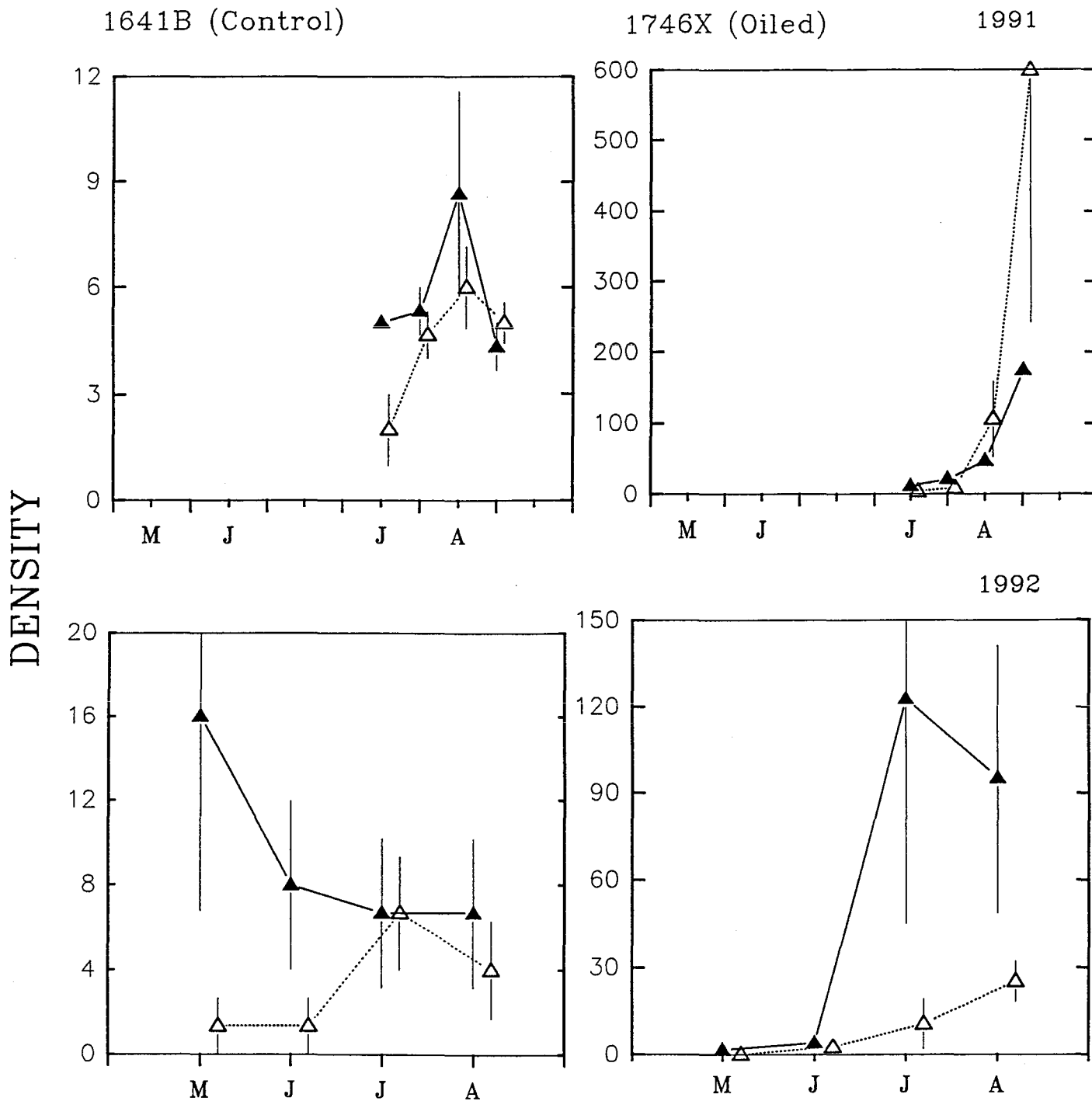

Figure 3.53. Density (No./0.01 m²) of barnacle recruits that settled on uncaged, tarred and scraped vertical rock faces at site pair 1746X during spring-fall 1991-1992. Site 1641B serves as the control match for this pair. Sampling of this site began in July, 1991. Layout same as Figure 3.48. N=3.

Barnacle juveniles - caged plots

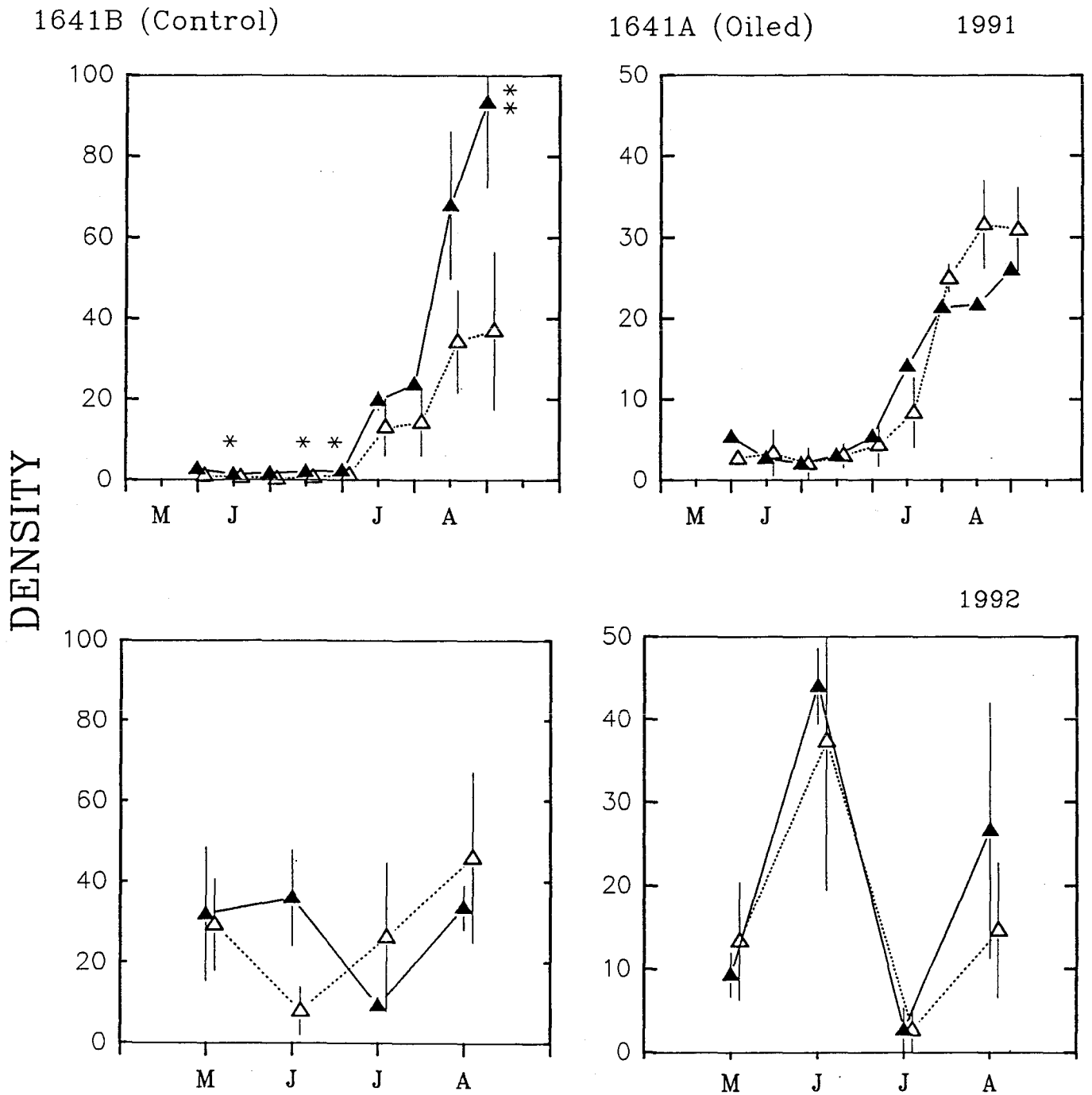

Figure 3.54. Density (No./0.01 m²) of barnacle recruits that settled on caged, tarred and scraped vertical rock faces at site pair 1641 during spring-fall 1991-1992. N=3. Layout same as Figure 3.48.

Barnacle juveniles – caged plots

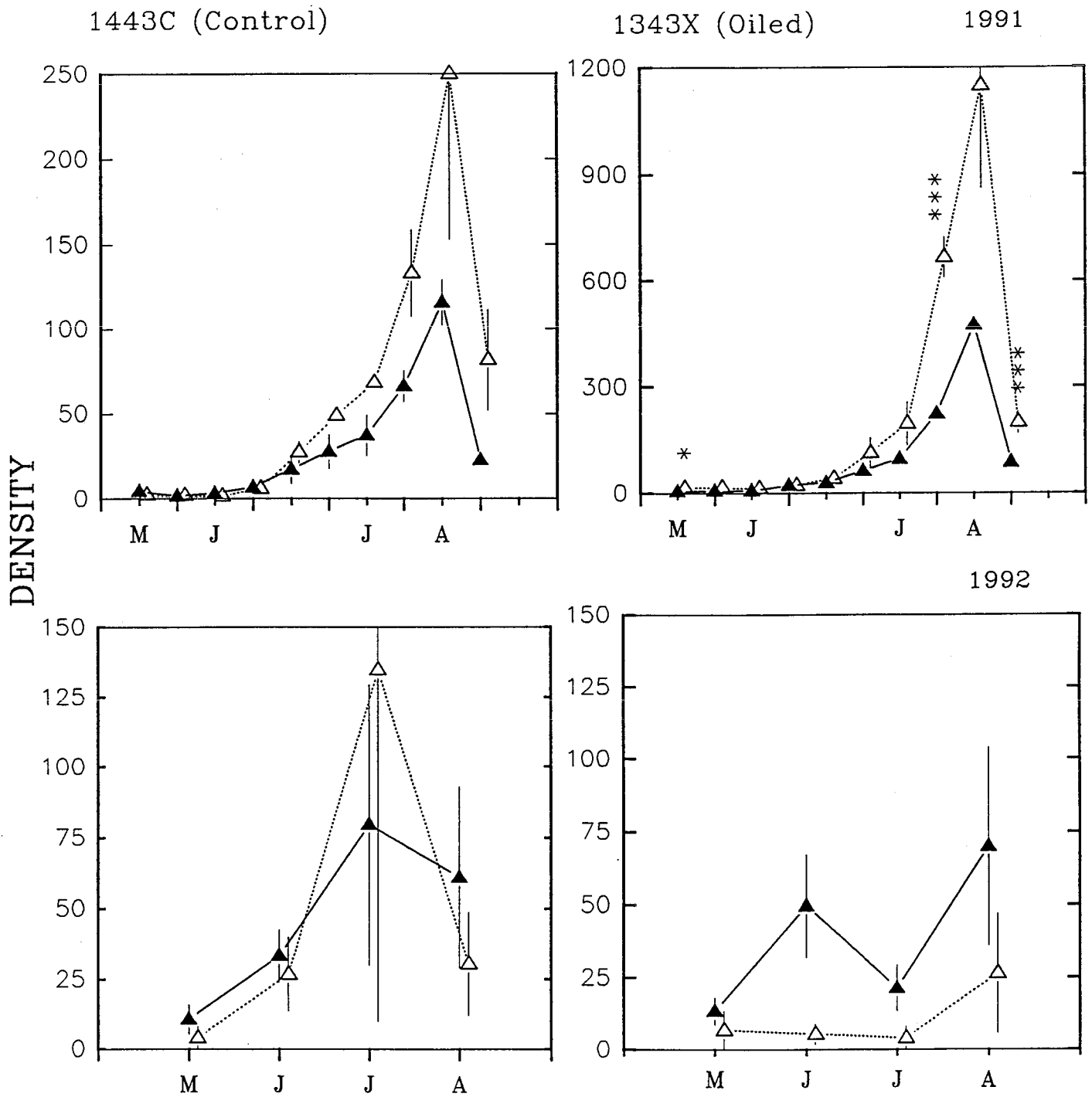

Figure 3.55. Density (No./0.01 m²) of barnacle recruits that settled on caged, tarred and scraped vertical rock faces at site pair 1443 during spring-fall 1991-1992. Layout same as Figure 3.48. N=3.

Barnacle juveniles – caged plots

1544C (Control)

1544X (Oiled)

1991

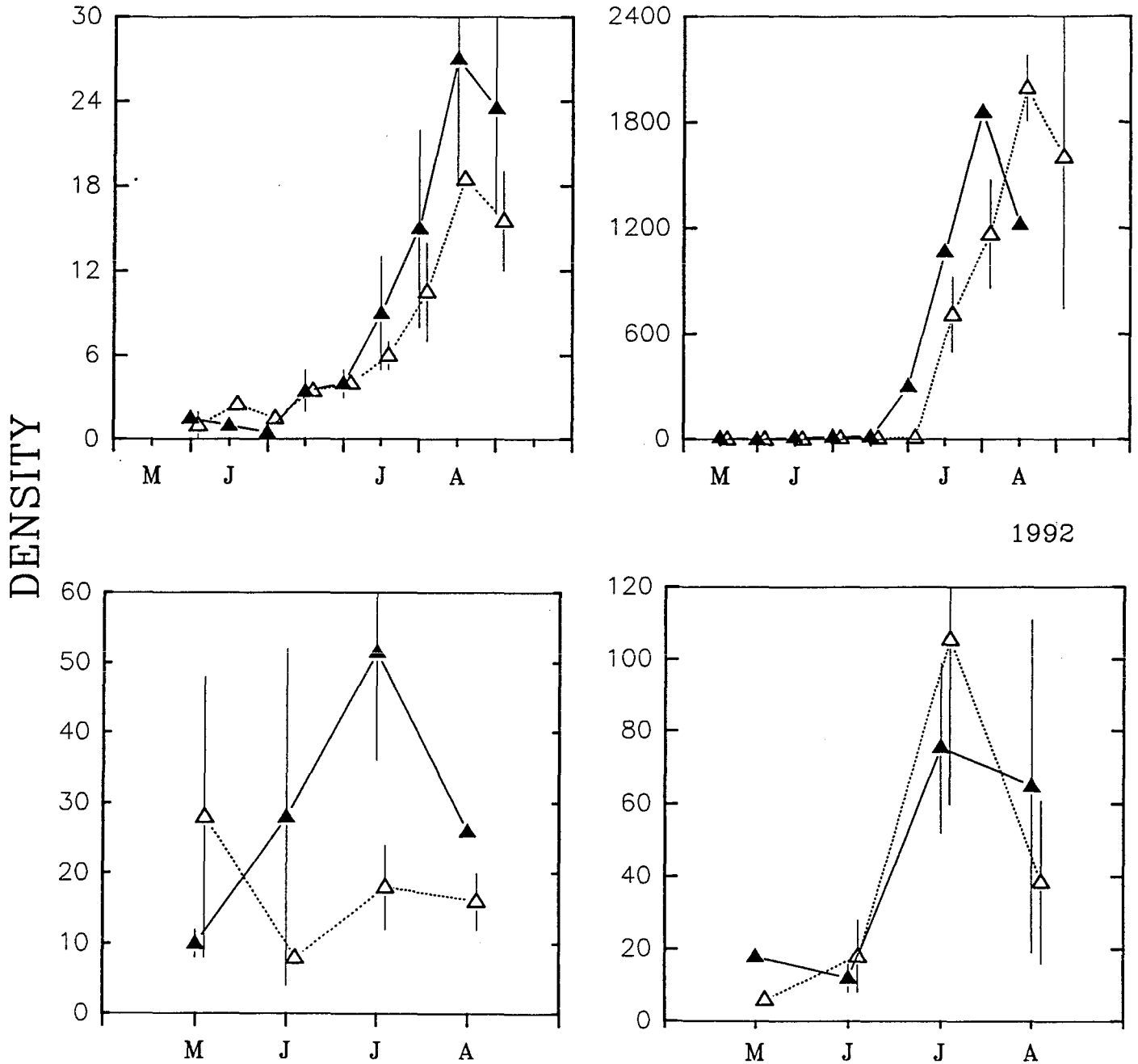

Figure 3.56. Density (No./0.01 m²) of barnacle recruits that settled on caged, tarred and scraped vertical rock faces at site pair 1544 during spring-fall 1991-1992. Layout same as Figure 3.48. N=2.

Barnacle juveniles – caged plots

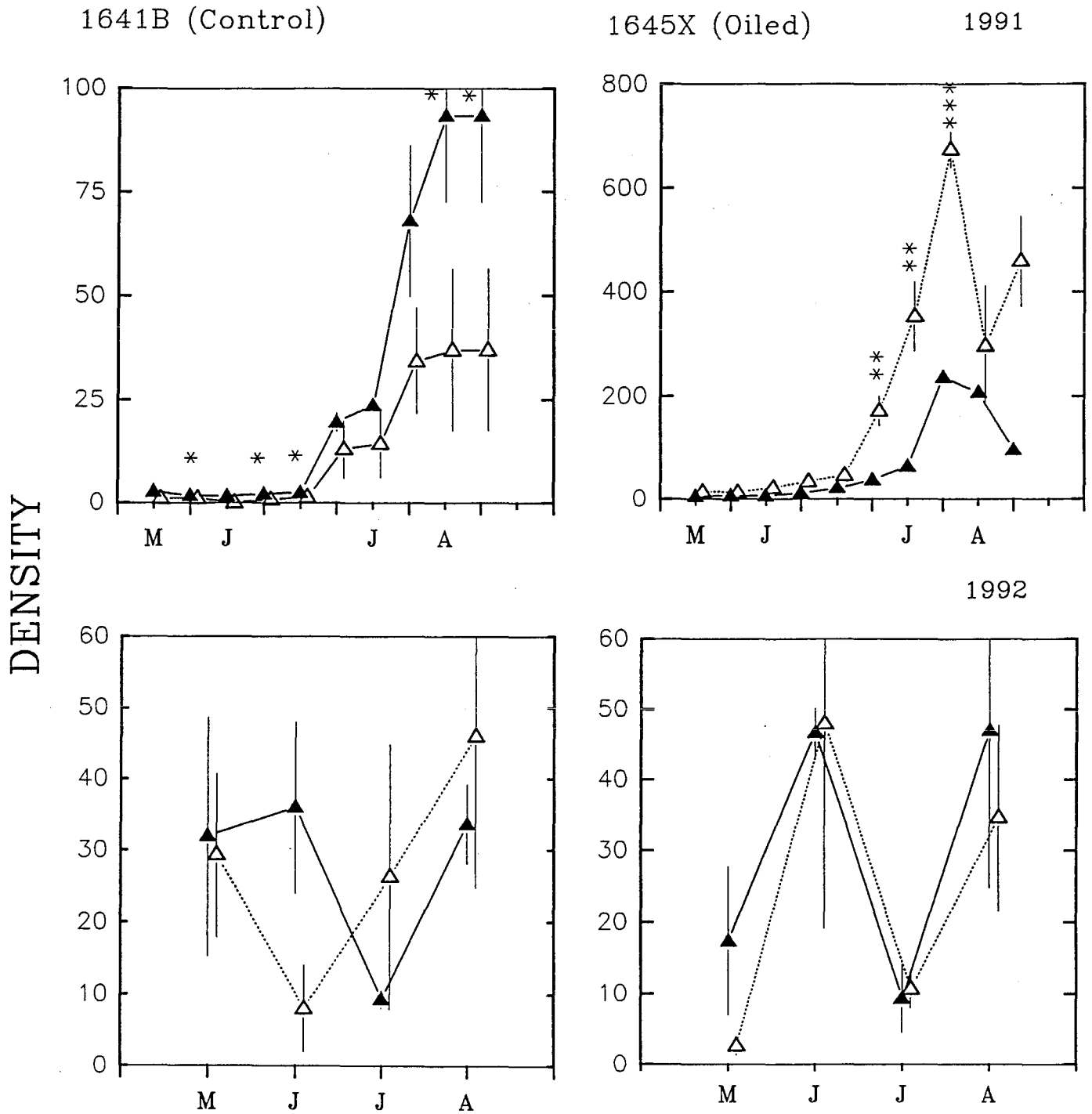

Figure 3.57. Density (No./0.01 m²) of barnacle recruits that settled on caged, tared and scraped vertical rock faces at site pair 1645X during spring-fall 1991-1992. Site 1641B serves as the control match for this pair. Layout same as Figure 3.48. N=3.

Barnacle juveniles – caged plots

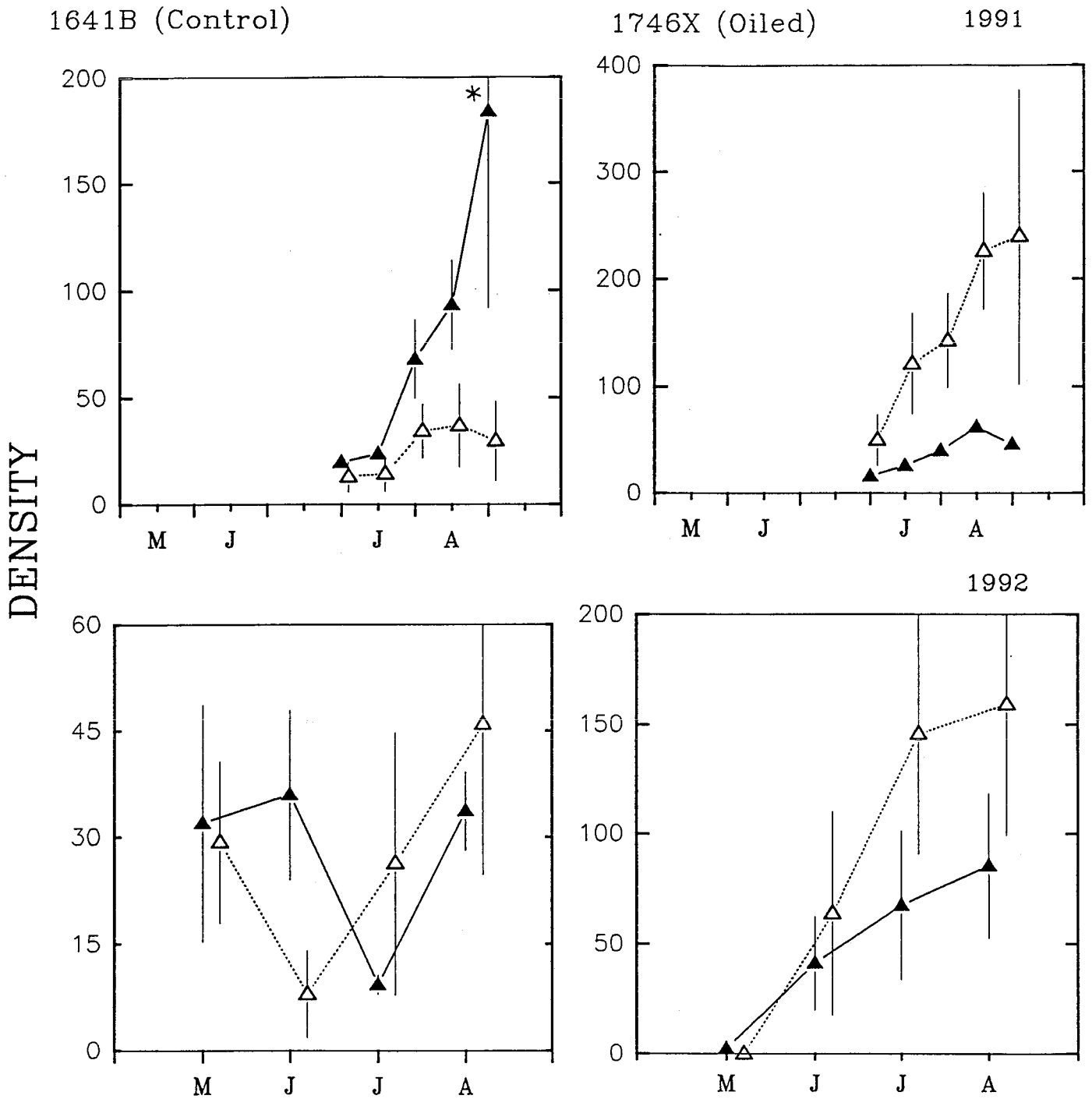
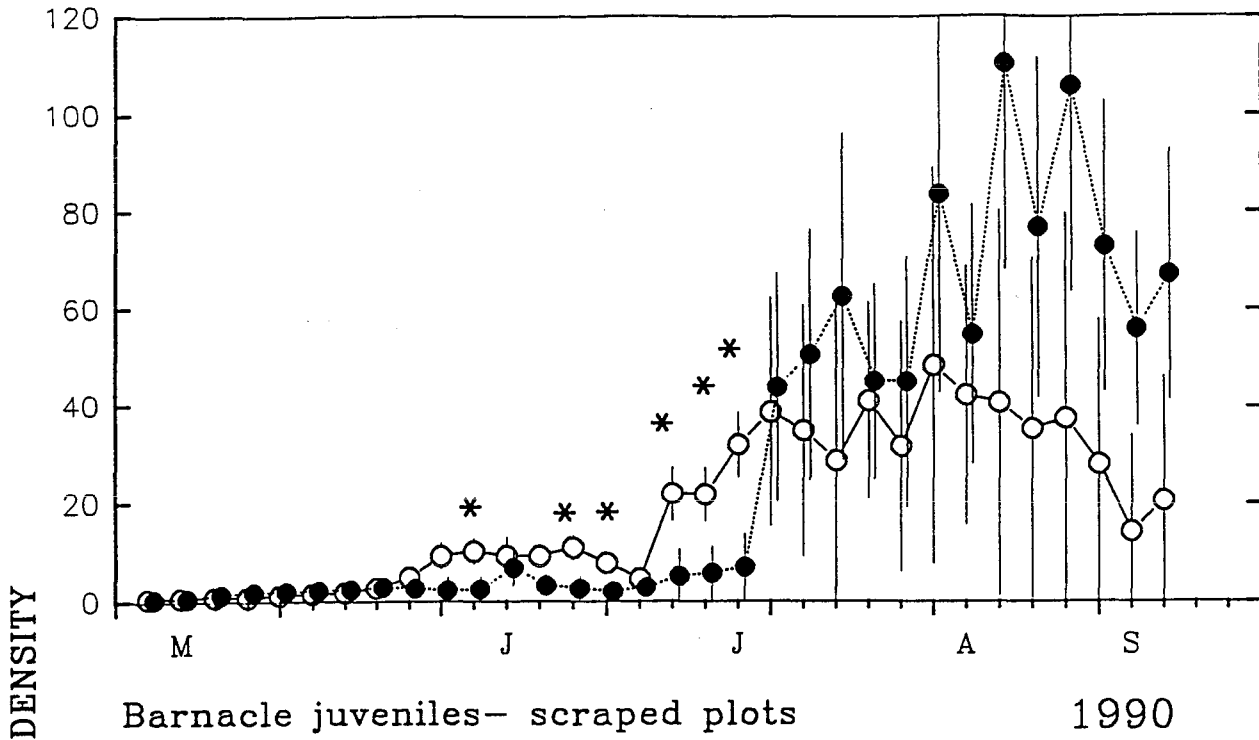

Figure 3.58. Density (No./0.01 m²) of barnacle recruits that settled on caged, tarred and scraped vertical rock faces at site pair 1746X during spring-fall 1991-1992. Site 1641B serves as the control match for this pair. Sampling of this site began in July, 1991. Layout same as Figure 3.48. N=3.

Barnacle juveniles- unscraped plots

1990



Barnacle juveniles- scraped plots

1990

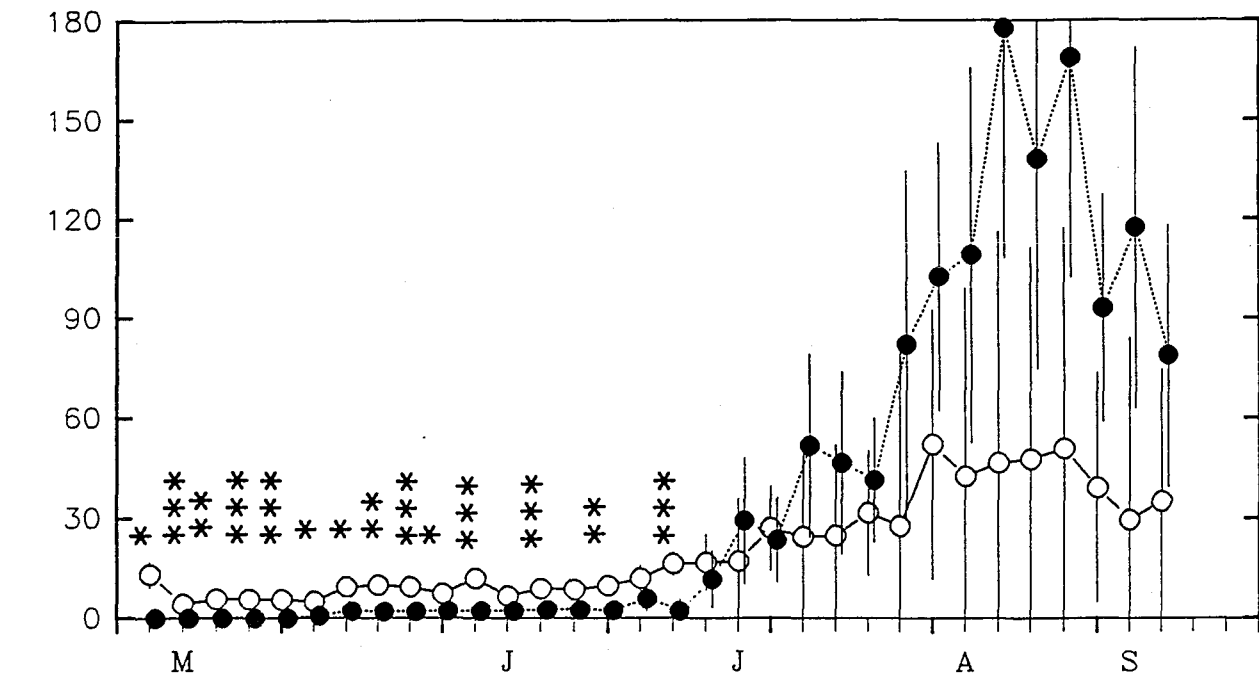

Figure 3.59. Density (No./0.01 m²) of barnacle juveniles compared between control and oiled sites (Fig. 3.48-3.49) on unscraped and scraped plots during 1990. All plots were uncaged. Control sites are open circles connected by solid lines. Oiled sites are solid circles, connected by dotted lines. Error bars represent plus and minus one standard error of the mean. There were 32 sample dates in 1990 between 5/30 and 9/21. Months are represented by letters on the X-axis. The asterisks represent statistical significance from ANOVA, blocking control and oiled sites (*=p<0.05, **=p<0.025, ***=p<0.01).

Barnacle juveniles - 1991

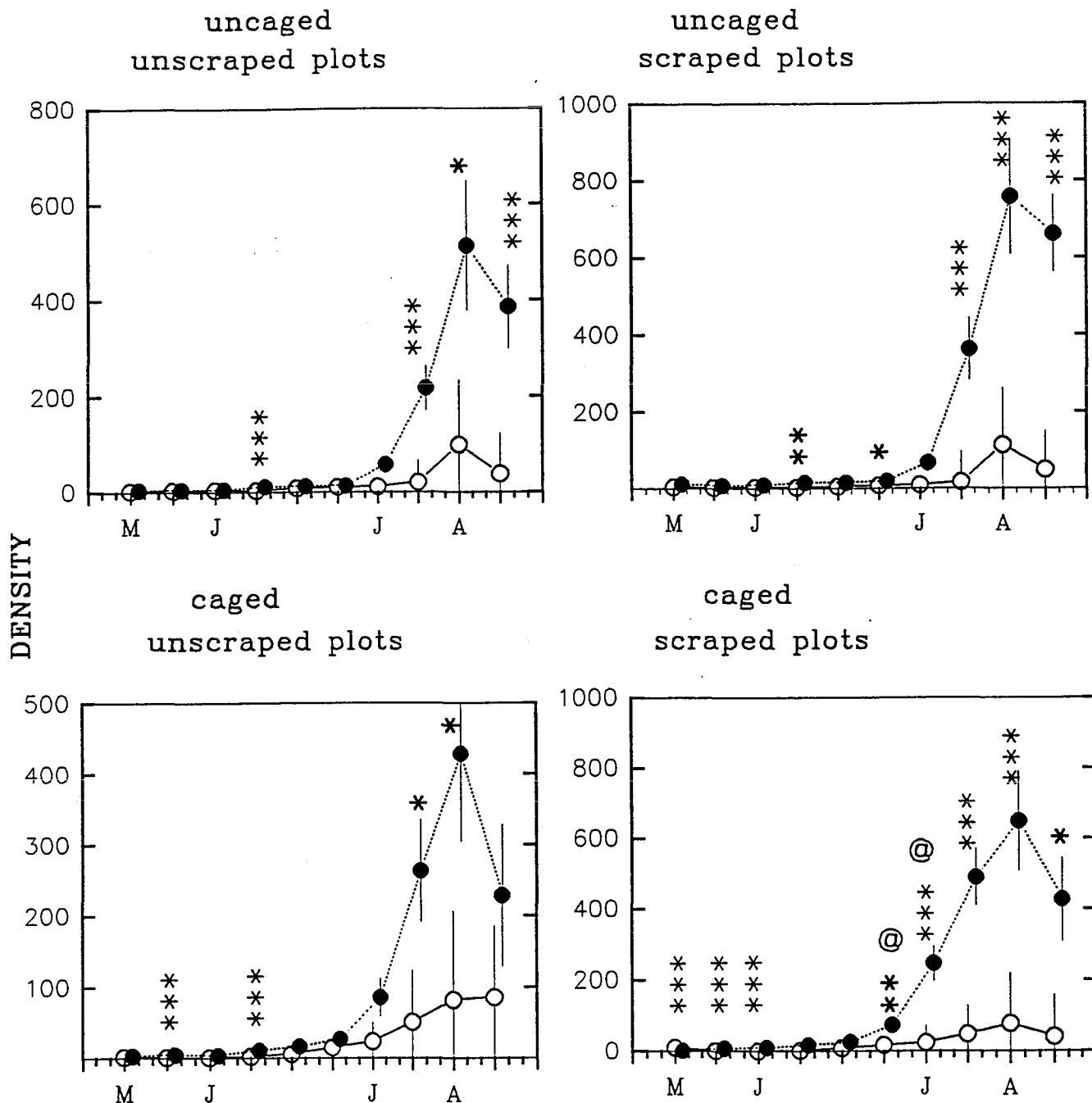

Figure 3.60. Density (No./0.01 m²) of barnacle juveniles compared between control and oiled sites on unscrapped and scraped plots during 1991. Treatments also include caged and uncaged plots. N=3 for each treatment. Control sites are open circles connected by solid lines. Oiled sites are solid circles connected by dotted lines. Error bars represent plus and minus one standard error of the mean. There were 10 sample dates in 1991 between 4/30 and 8/26. Months are represented by letters on the X-axis. The asterisks represent statistical significance from ANOVA, blocking control and oiled sites (*=p≤0.05, **=p≤0.025, ***=p≤0.01). The @ represents significance (p≤0.05, ANOVA) between caged and uncaged plots of like treatments.

Barnacle juveniles- 1992

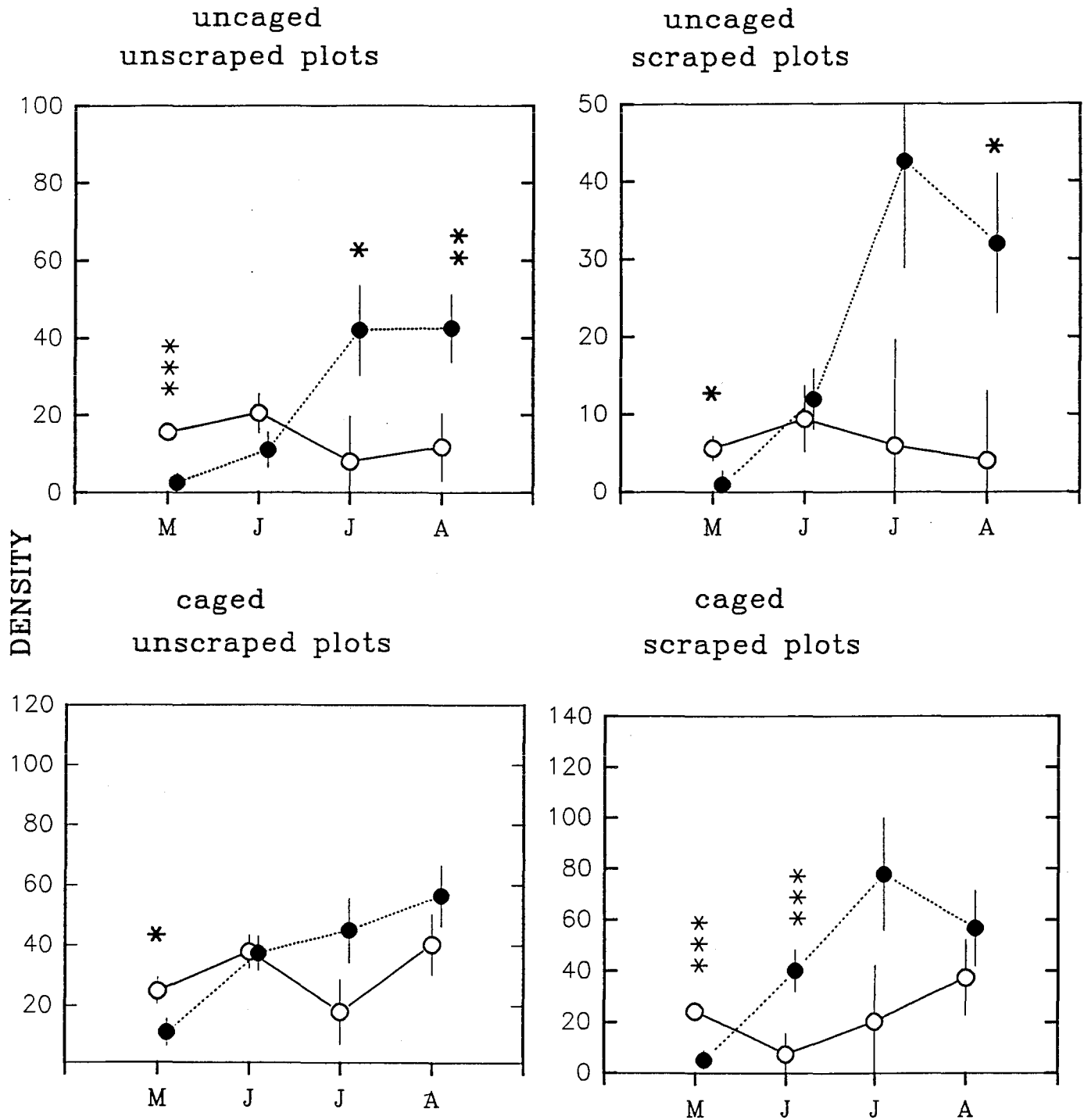

Figure 3.61. Density (No./0.01 m²) of barnacle juveniles compared between control and oiled sites on unscrapped and scraped plots during 1992. Treatments also included caged and uncaged plots. N=3 for each treatment. Control sites are open circles connected by solid lines. Oiled sites are solid circles connected by dotted lines. There were 4 sample dates in 1992 between 5/31 and 8/27. Months are represented by letters on the X-axis. The asterisks represent statistical significance from ANOVA, blocking control and oiled sites (*=p≤0.05, **=p≤0.025, ***=p≤0.01).

barnacle adults - uncaged plots

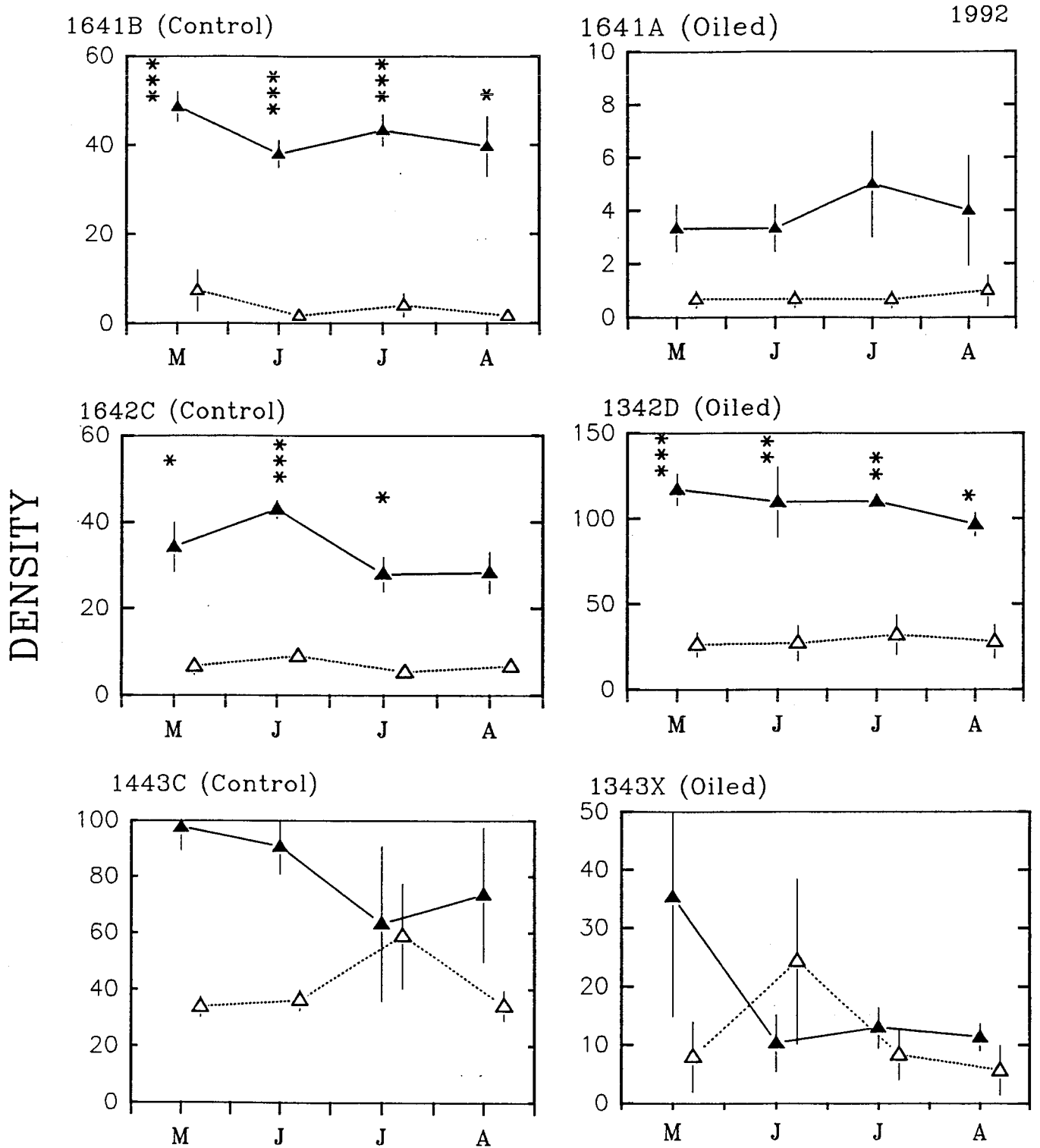

Figure 3.62. Density (No./0.01 m²) of barnacle adults (all species except *C. dalli* combined) that settled on uncaged, tarred and scraped vertical rock faces at site pairs 1641, 1642, and 1443 during the spring-fall of 1992. N=3. Layout same as Figure 3.48.

barnacle adults - uncaged plots

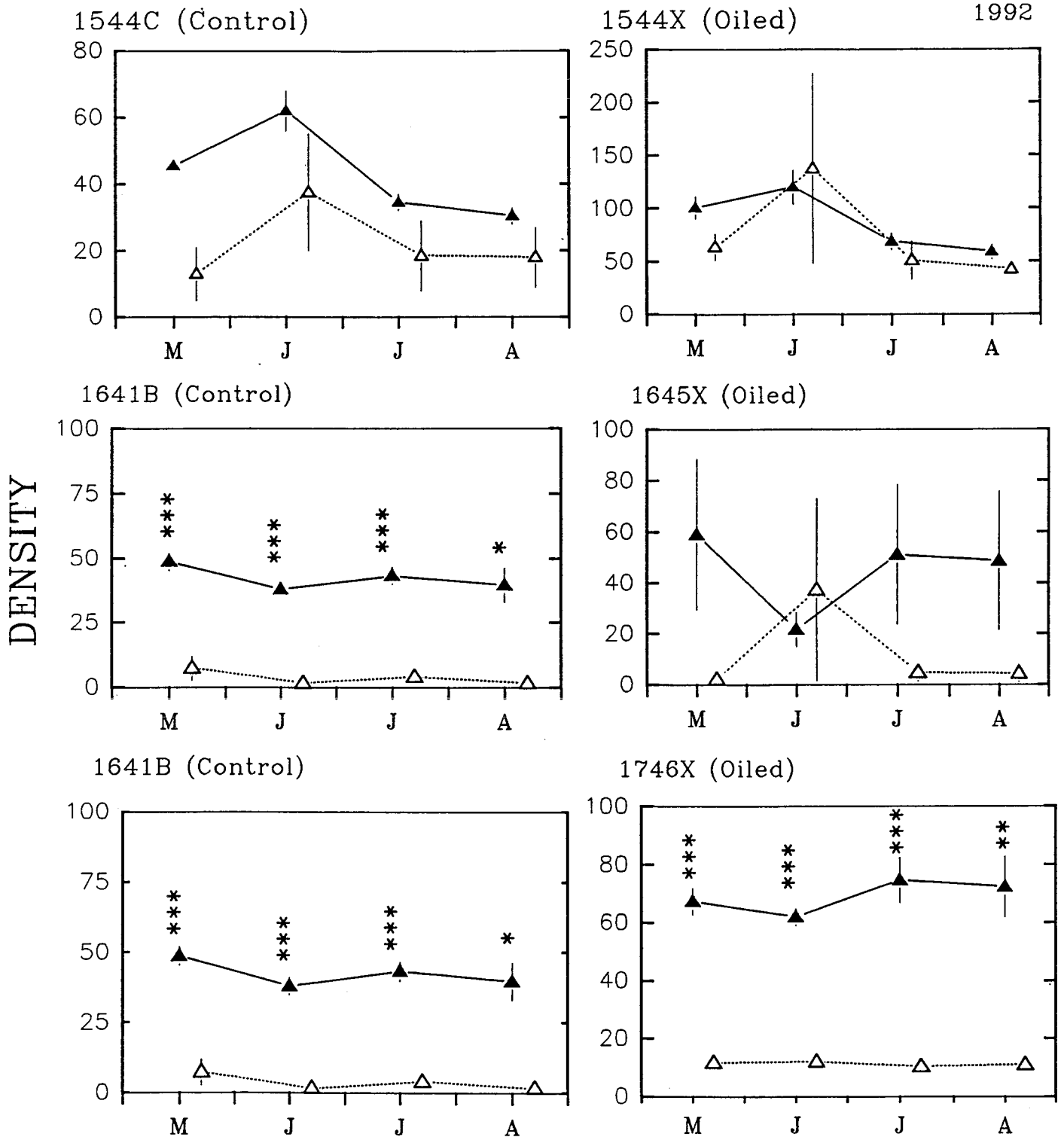

Figure 3.63. Density (No./0.01 m²) of barnacle adults (all species except *C. dalli*) that settled on uncaged, tarred and scraped vertical rock faces at site pair 1544 1645X, and 1746X during the spring-fall of 1992. Layout same as Figure 3.48. N=3 for sites, except 1544 (N=2).

barnacle adults - caged plots

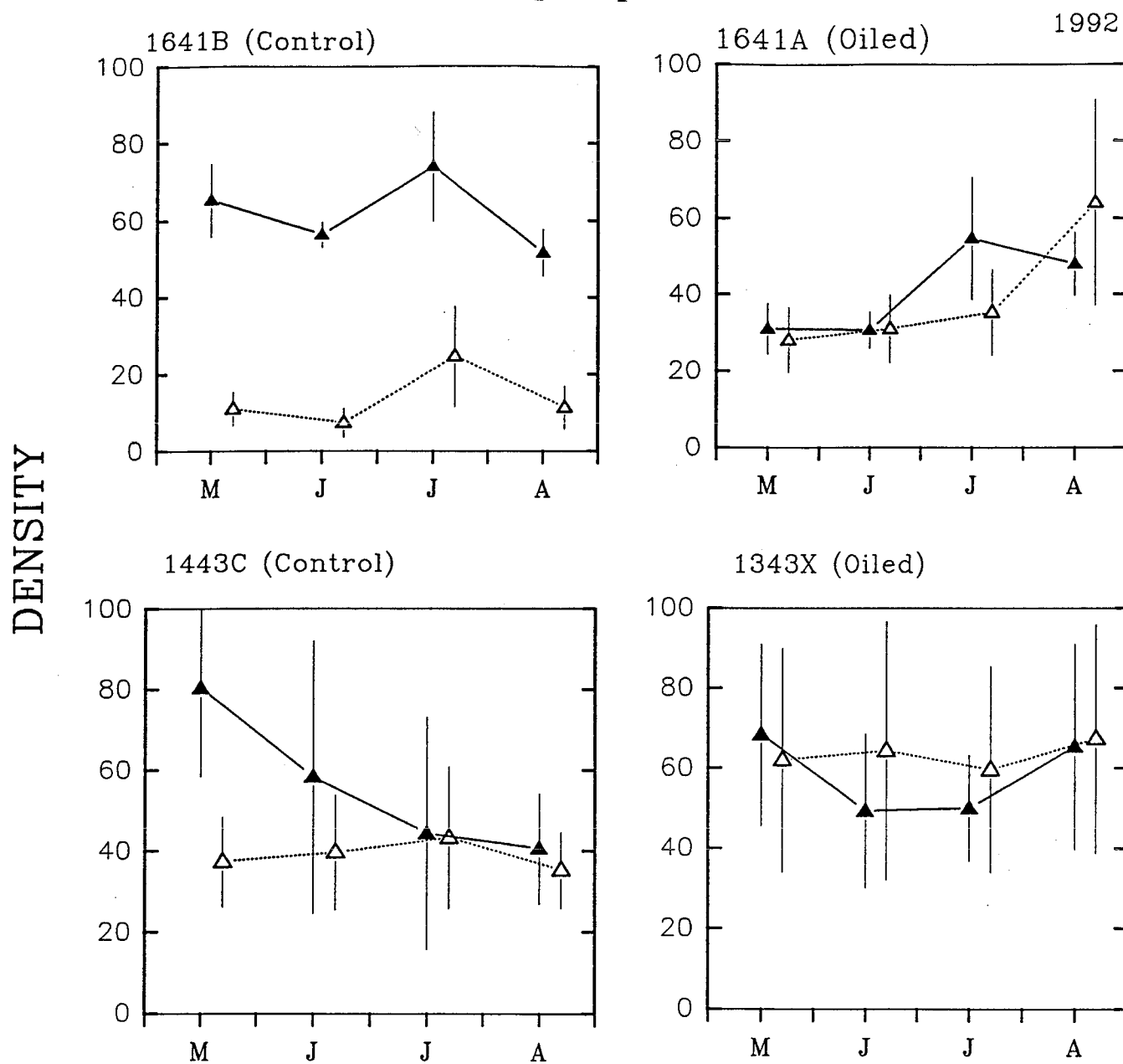

Figure 3.64. Density (No./0.01 m²) of barnacle adults (all species except *C. dalli*) that settled on caged, tarred and scraped vertical rock faces at site pairs 1641 and 1443 during the spring-fall of 1992. N=3. Layout same as Figure 3.48.

barnacle adults - caged plots

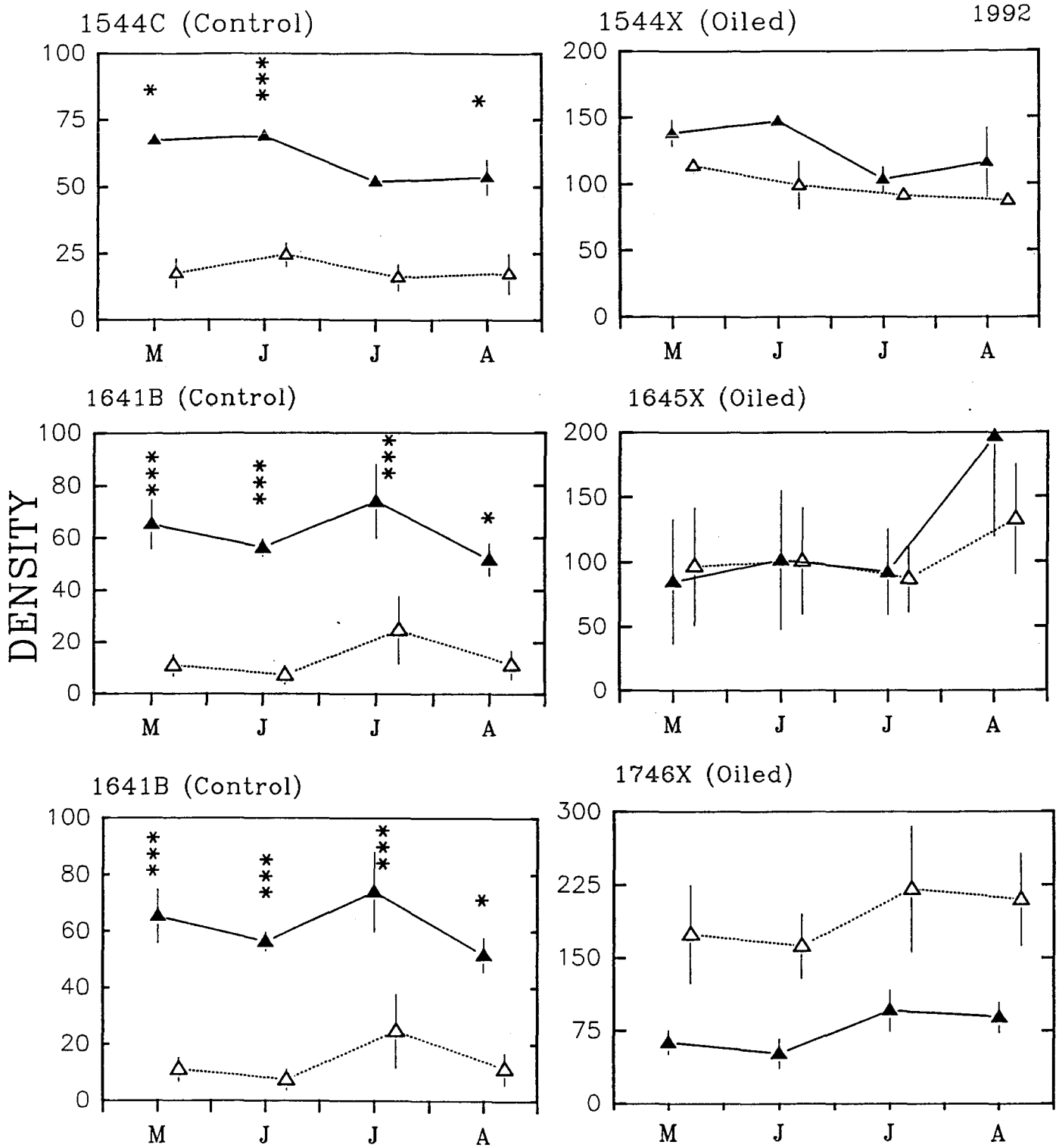

Figure 3.65. Density (No./0.01 m²) of barnacle adults (all species except *C. dalli*) that settled on caged, tarred and scraped vertical rock faces at site pair 1544, 1645X and 1746X during the spring-fall of 1992. Layout same as Figure 3.48. N=3 for sites, except 1544 (N=2).

Barnacle adults- 1992

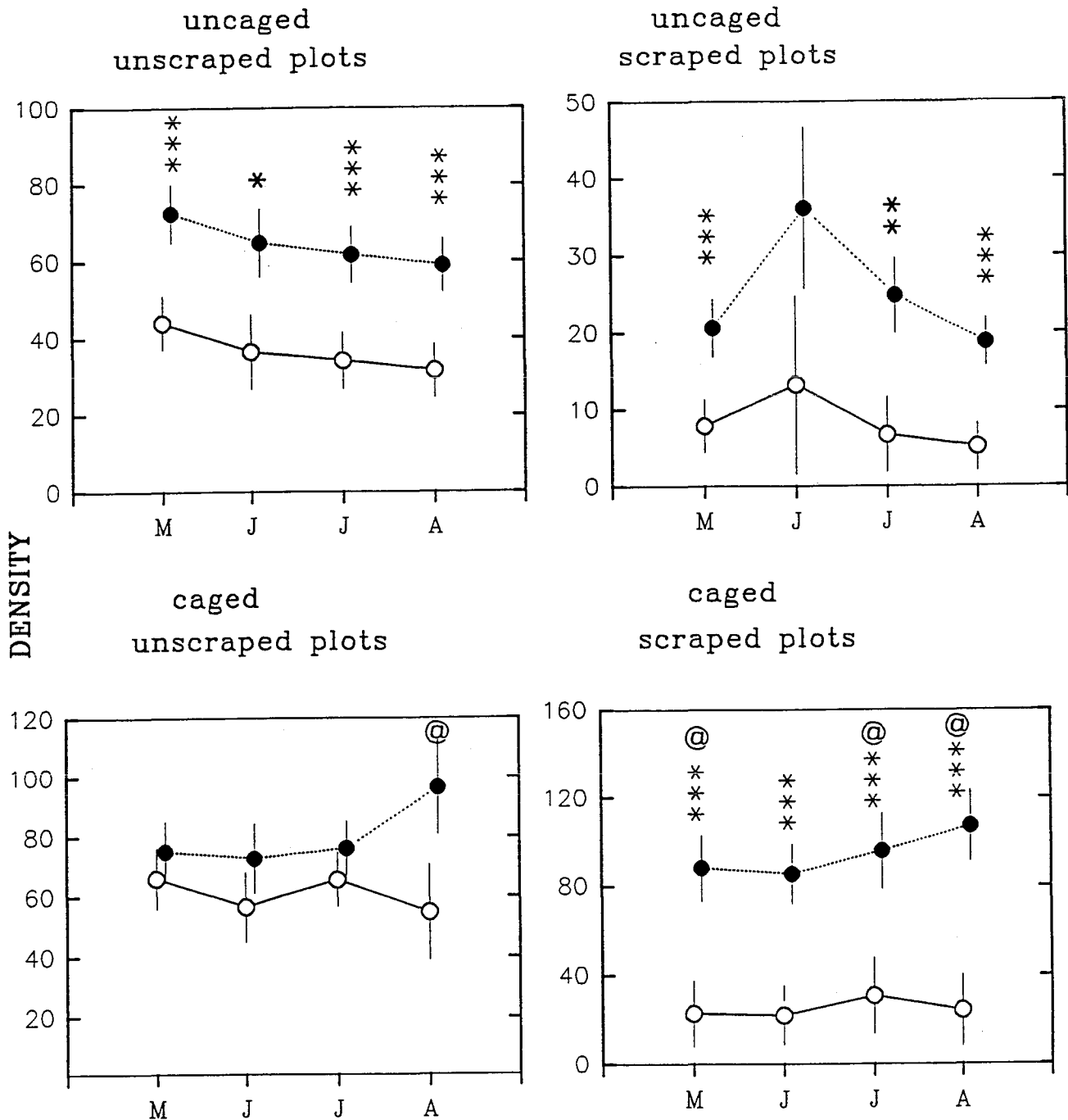

Figure 3.66. Density (No./0.01 m²) of barnacle adults (except *C. dalli*) compared between control and oiled sites on unscrapped and scraped plots during 1992. Treatments also include caged and uncaged plots. N=3 for each treatment. Control sites are open circles connected by solid lines. Oiled sites are solid circles connected by dotted lines. There were 4 sample dates in 1992 between 5/31 and 8/27. Months are represented by letters on the X-axis. The asterisks represent statistical significance from ANOVA, blocking control and oiled sites (*=p<0.05, **=p<0.025, ***=p<0.01). The @ represents significance (p<0.05, ANOVA) between caged and uncaged plots of like treatments.

Chthamalus dalli - uncaged plots

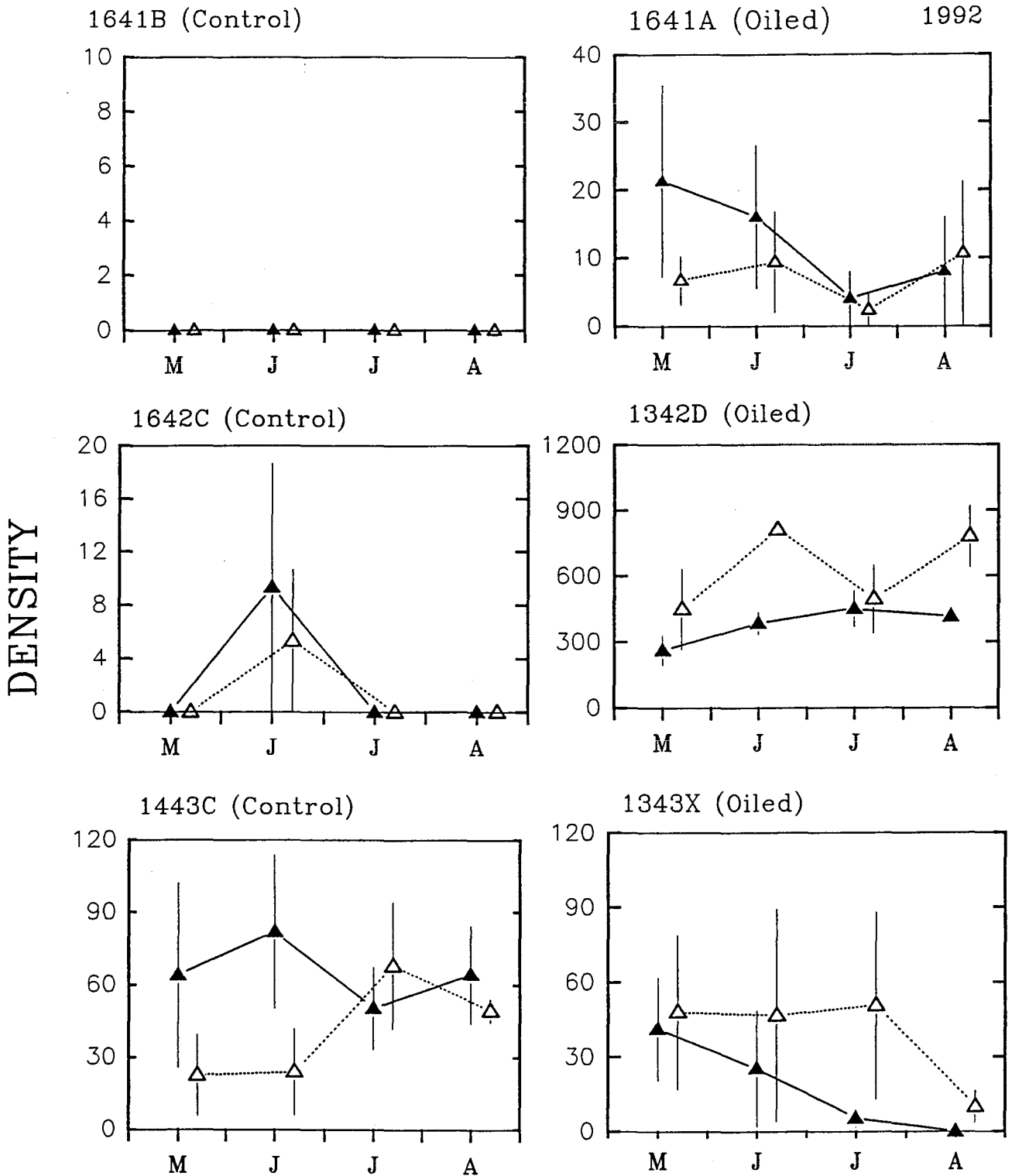

Figure 3.67. Density (No./0.01 m²) of *Chthamalus dalli* that settled on uncaged, tarred and scraped vertical rock faces at site pairs 1641, 1642, and 1443 during the spring-fall of 1992. N=3. Layout same as Figure 3.48.

Chthamalus dalli - uncaged plots

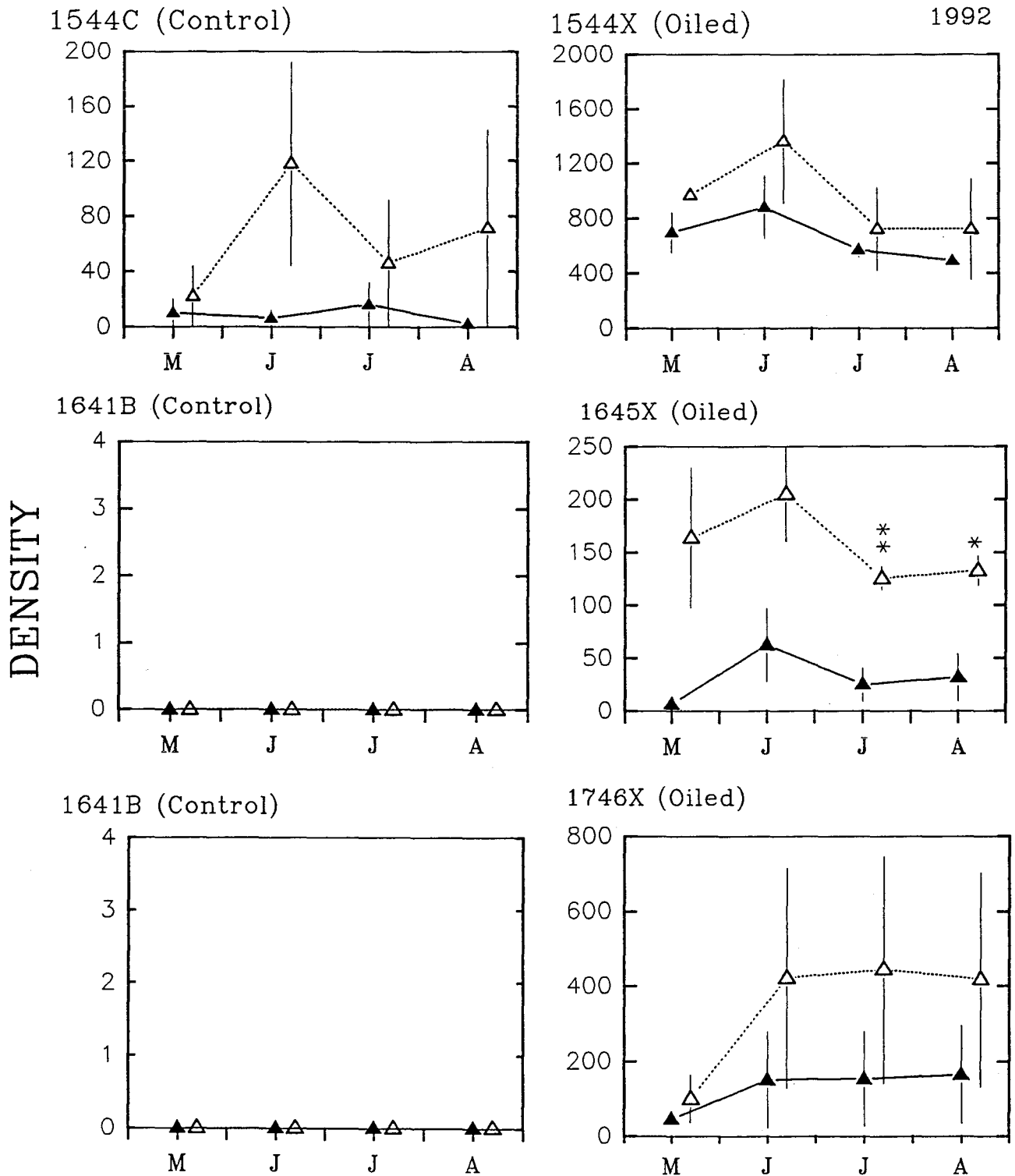

Figure 3.68. Density (No./0.01 m²) of *Chthamalus dalli* that settled on uncaged, tarred and scraped vertical rock faces at site pair 1544 1645X, and 1746X during the spring-fall of 1992. Layout same as Figure 3.48. N=3 for sites, except 1544 (N=2).

Chthamalus dalli - caged plots

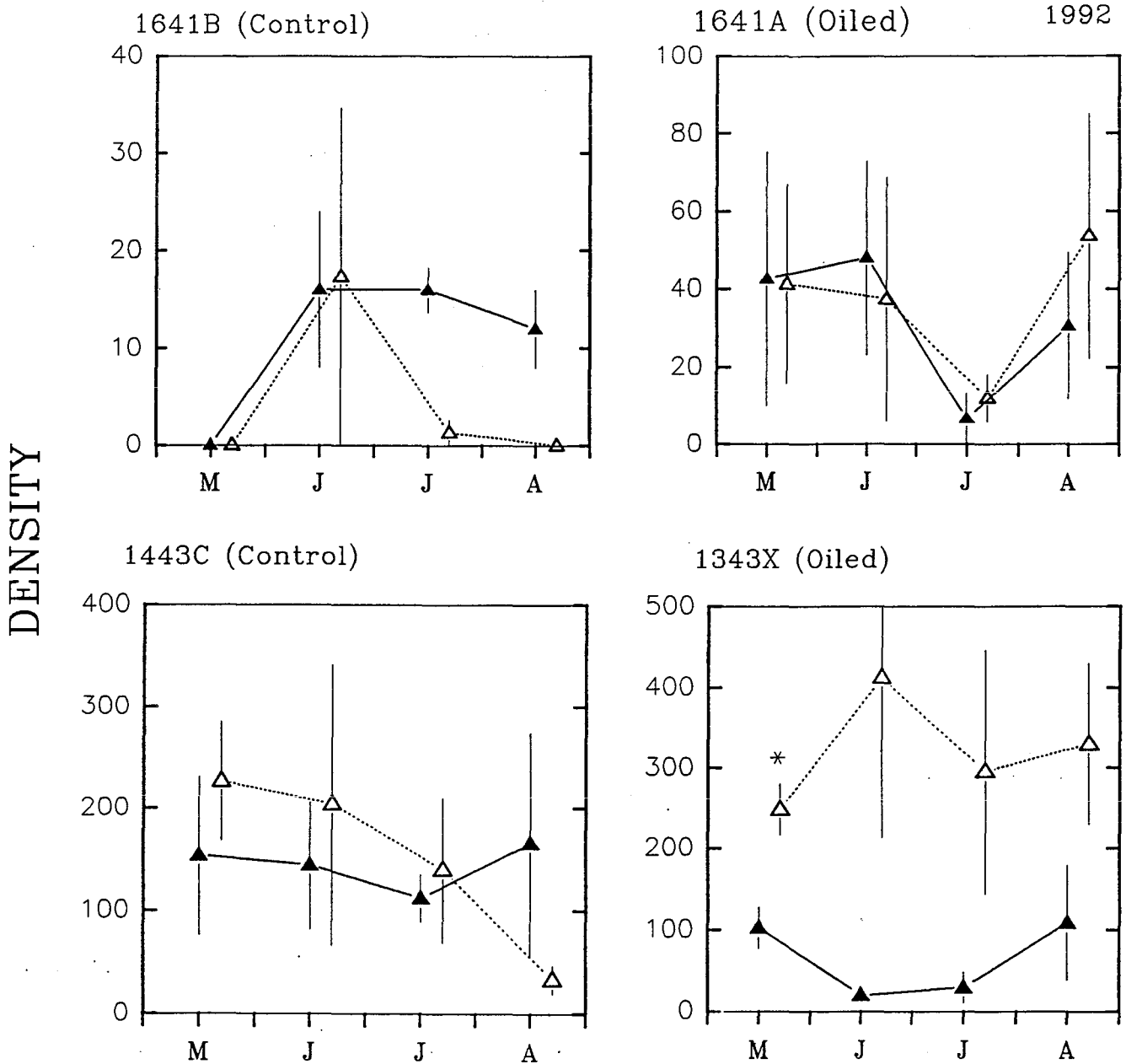

Figure 3.69. Density (No./0.01 m²) of *Chthamalus dalli* that settled on caged, tarred and scraped vertical rock faces at site pairs 1641 and 1443 during the spring-fall of 1992. N=3. Layout same as Figure 3.48.

Chthamalus dalli - caged plots

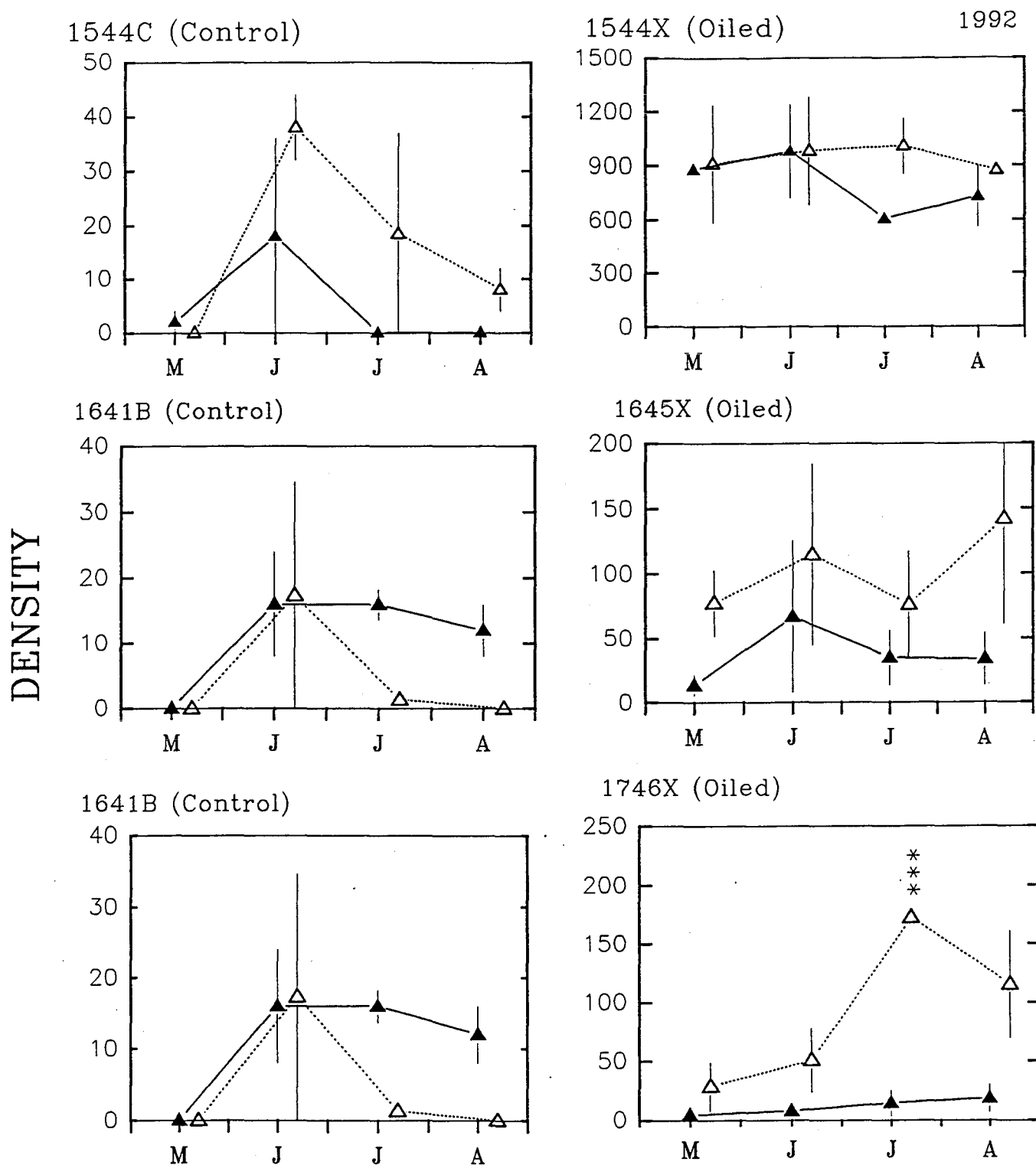

Figure 3.70. Density (No./0.01 m²) of *Chthamalus dalli* that settled on uncaged, tarred and scraped vertical rock faces at site pair 1544 1645X, and 1746X during the spring-fall of 1992. Layout same as Figure 3.48. N=3 for sites, except 1544 (N=2).

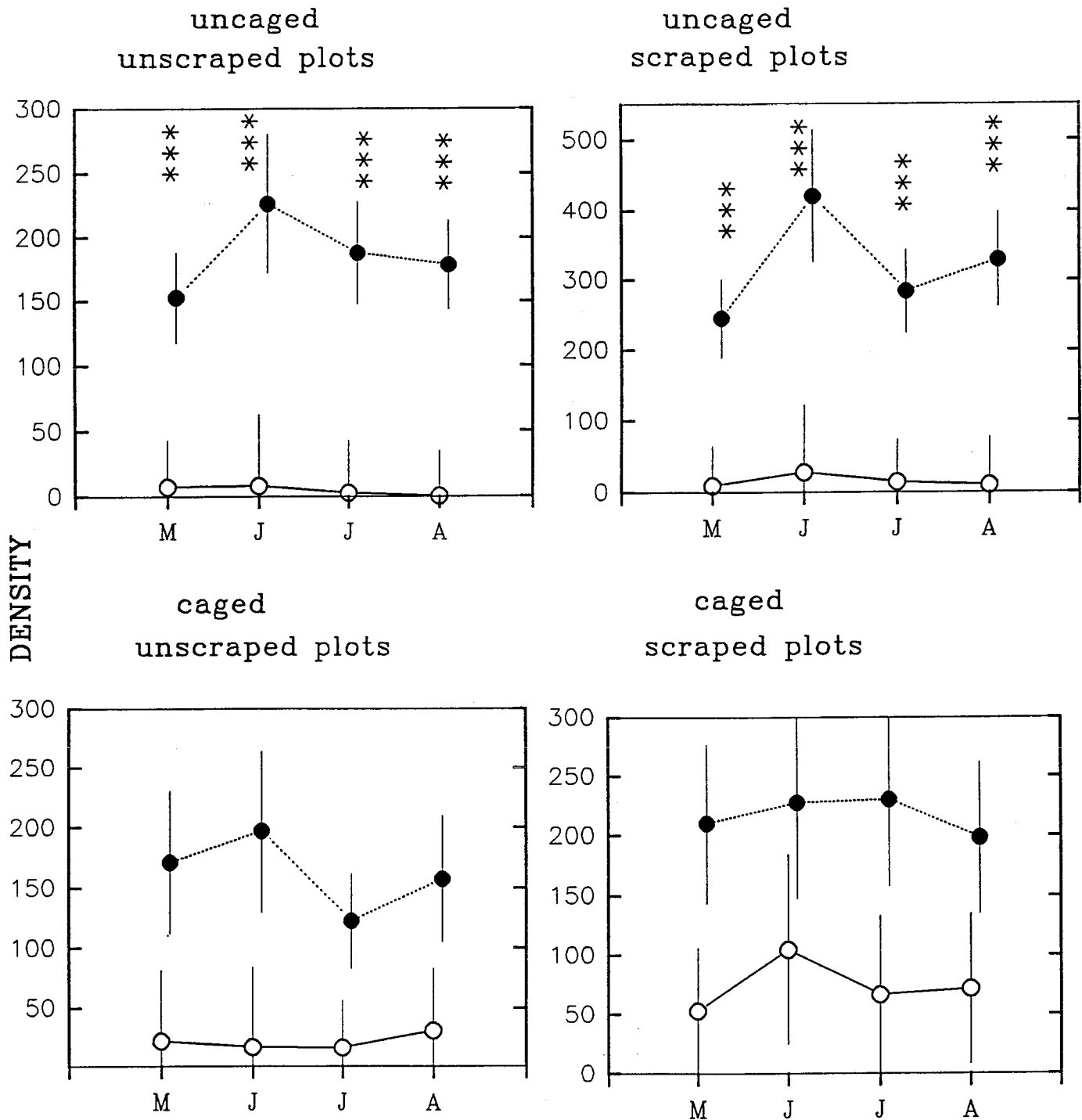

Figure 3.71. Density (No./0.01 m²) of *Chthamalus dalli* compared between control and oiled sites on unscrapped and scraped plots during 1992. Treatments also include caged and uncaged plots. N=3 for each treatment. Control sites are open circles connected by solid lines. Oiled sites are solid circles connected by dotted lines. There were 4 sample dates in 1992 between 5/31 and 8/27. Months are represented by letters on the X-axis. The asterisks represent statistical significance from ANOVA, blocking control and oiled sites (*=p≤0.05, **=p≤0.025, ***=p≤0.01).

Fucus germlings - uncaged plots

1641B (Control)

1641A (Oiled)

1990

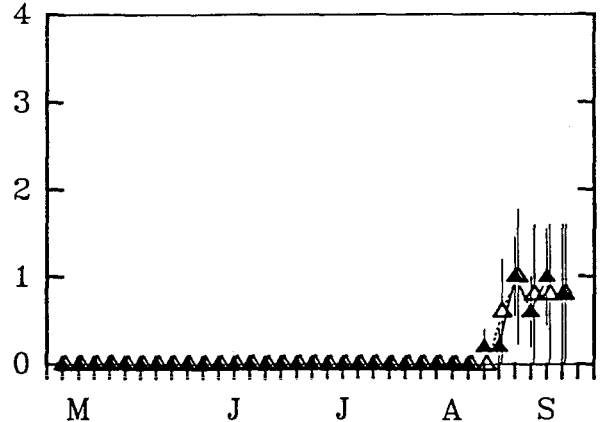
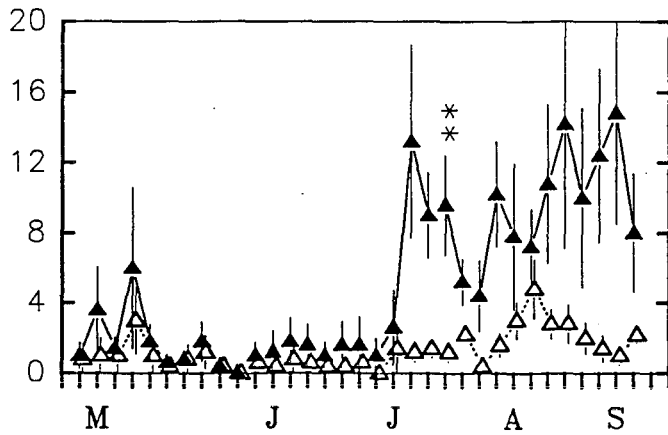

1991

DENSITY

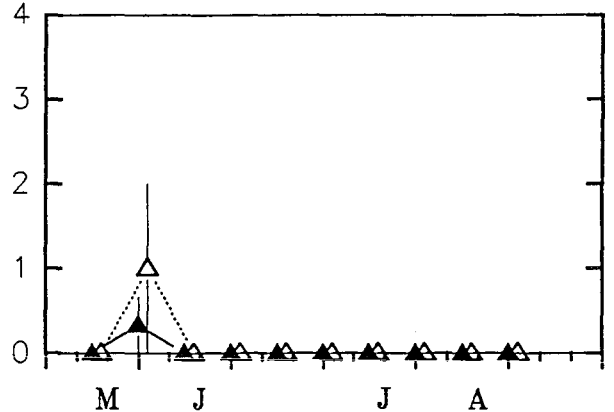
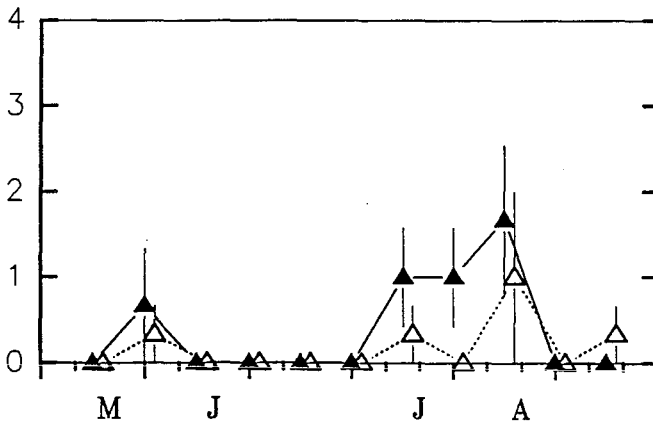

1992

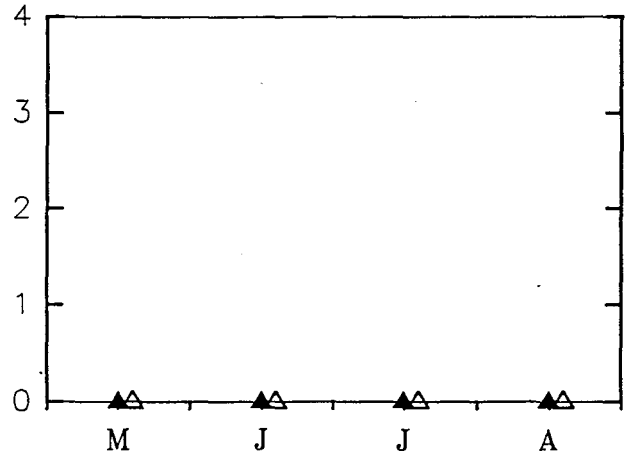
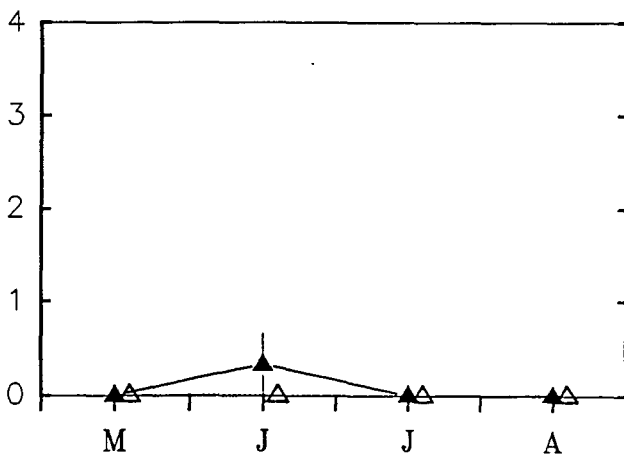

Figure 3.72. Density (No./0.01 m²) of *Fucus* germlings that settled on uncaged, tarred and scraped vertical rock faces at site pair 1641 during spring-fall 1990-1992. N=5 for 1990. N=3 for 1991 and 1992. Layout same as Figure 3.48. Note scale differences.

Fucus germlings - uncaged plots

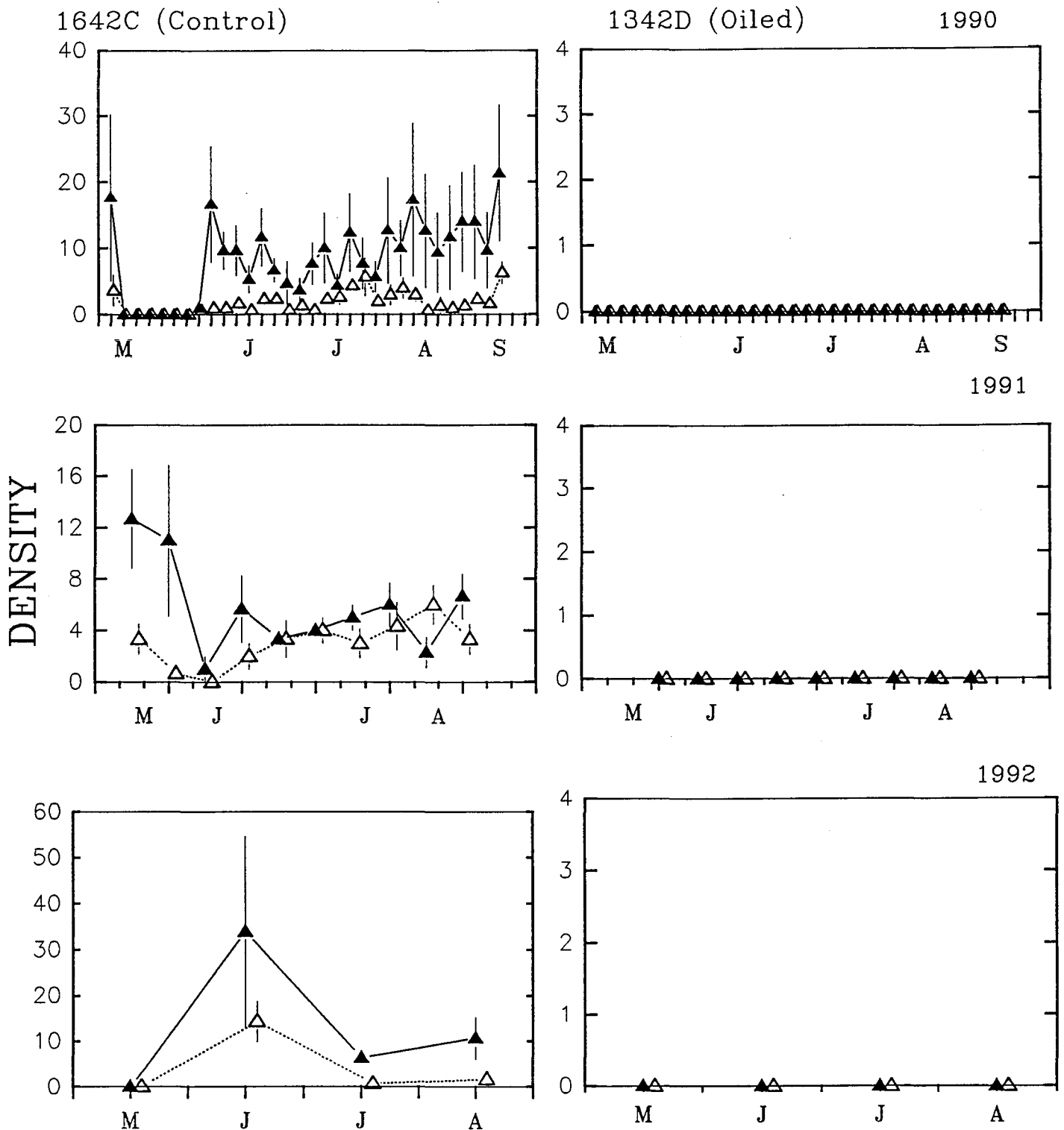

Figure 3.73. Density (No./0.01 m²) of *Fucus* germlings that settled on uncaged, tarred and scraped vertical rock faces at site pair 1642 during spring-fall 1990-1992. N=3 for all years. Layout same as Figure 3.48.

Fucus germlings - uncaged plots

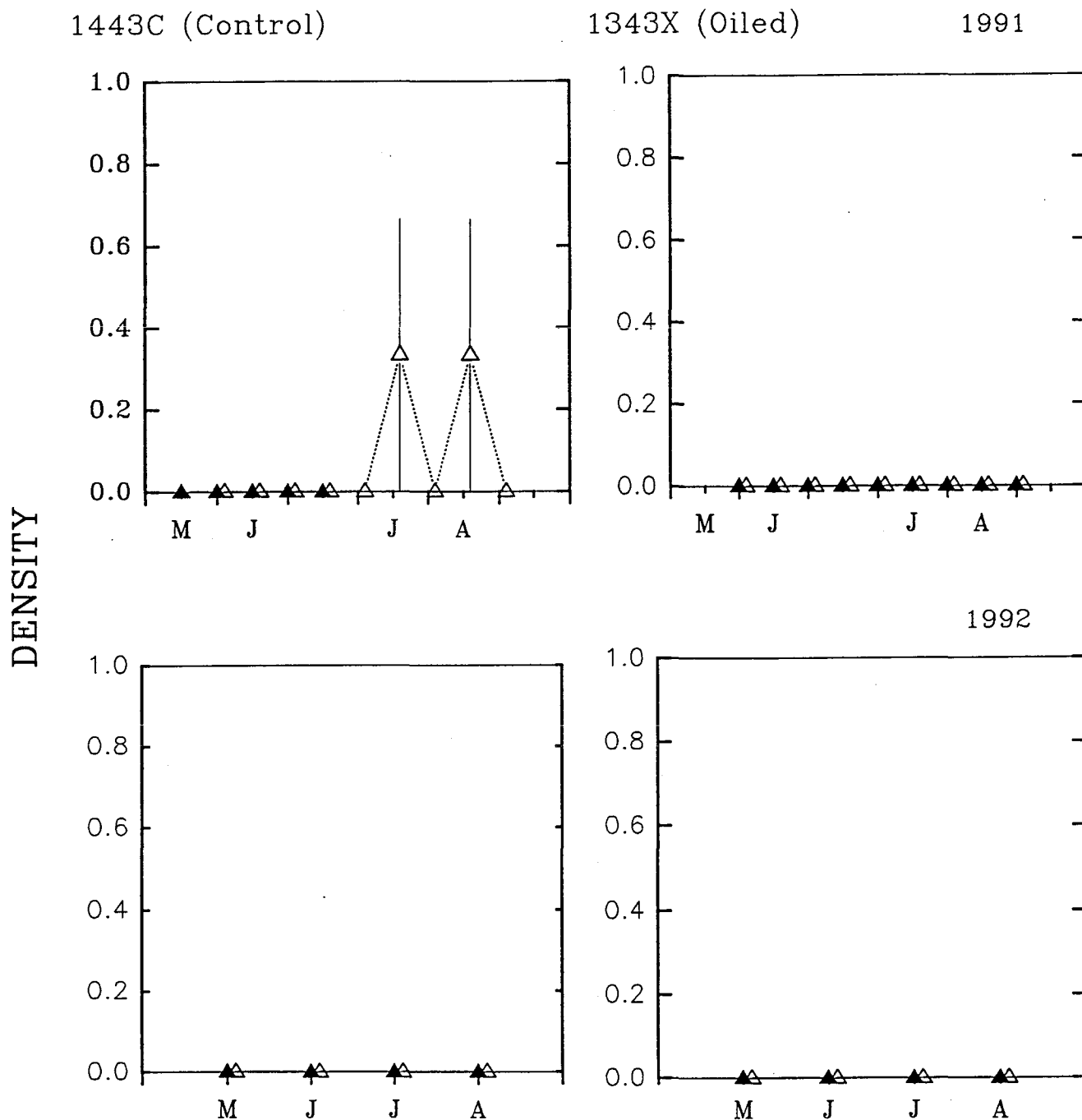

Figure 3.74. Density (No./0.01 m²) of *Fucus* germlings that settled on uncaged, tarred and scraped vertical rock faces at site pair 1443 during spring-fall 1991-1992. Layout same as Figure 3.48. N=3.

Fucus germlings – uncaged plots

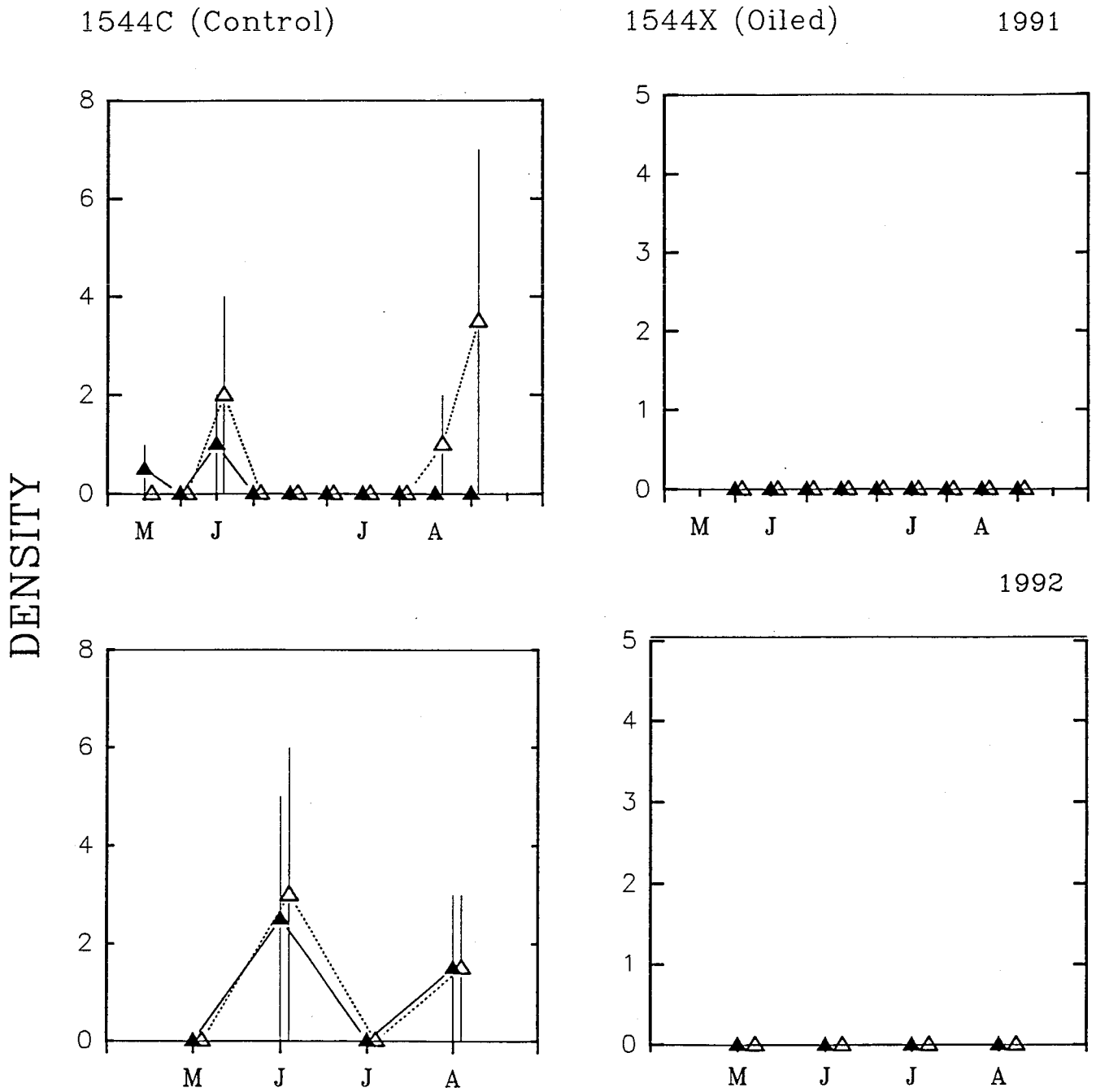

Figure 3.75. Density (No./0.01 m²) of *Fucus* germlings that settled on uncaged, tarred and scraped vertical rock faces at site pair 1544 during spring-fall 1991-1992. Layout same as Figure 3.48. N=2.

Fucus germlings – uncaged plots

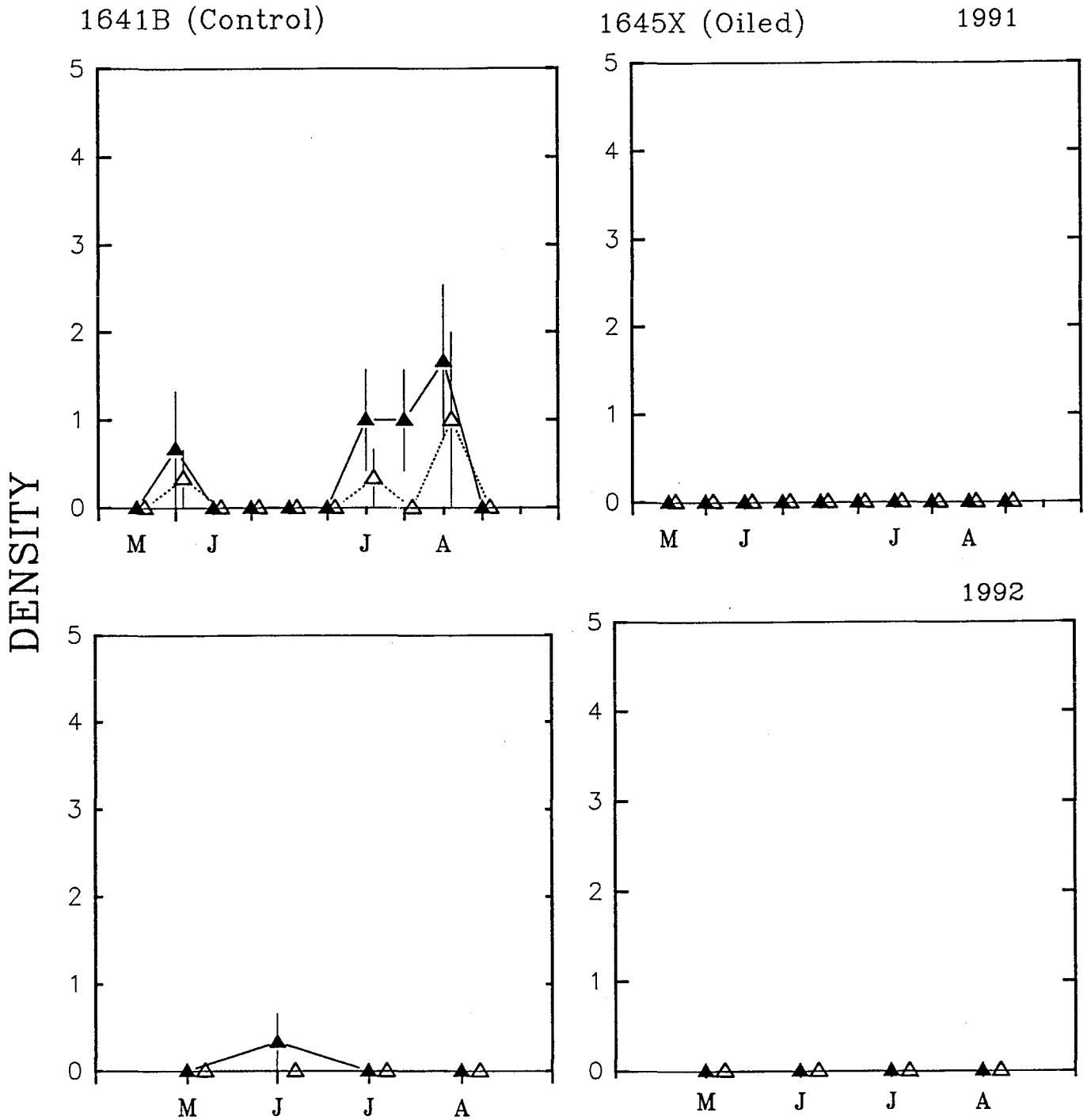

Figure 3.76. Density (No./0.01 m²) of *Fucus* germlings that settled on uncaged, tarred and scraped vertical rock faces at site pair 1645X during spring-fall 1991-1992. Site 1641B serves as the control match for this pair. Layout same as Figure 3.48. N=3.

Fucus germlings - uncaged plots

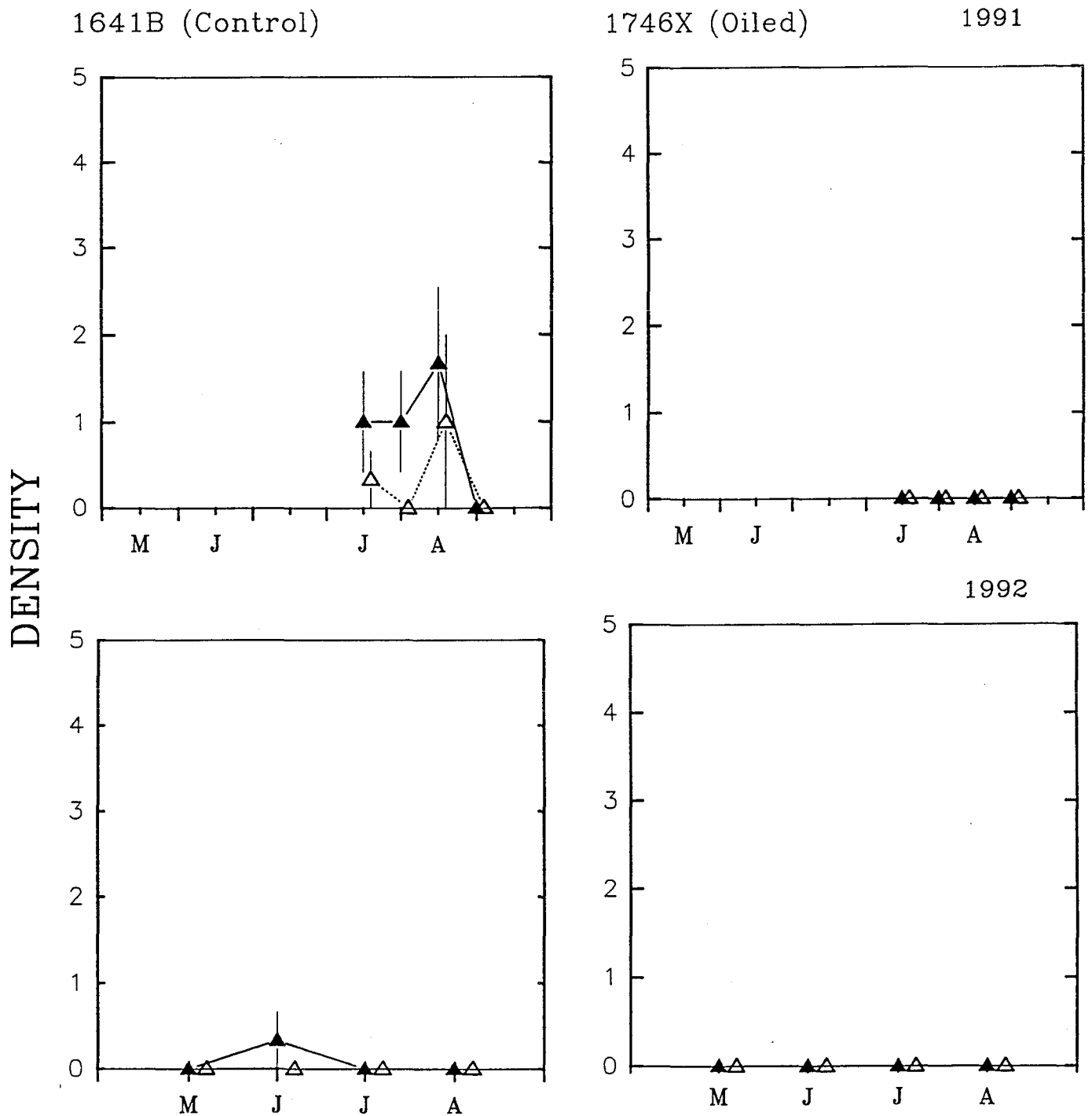

Figure 3.77. Density (No./0.01 m²) of *Fucus* germlings that settled on uncaged, tarred and scraped vertical rock faces at site pair 1746X during spring-fall 1991-1992. Site 1641B serves as the control match for this pair. Sampling of this site began in July, 1991. Layout same as Figure 3.48. N=3.

Fucus germlings - caged plots

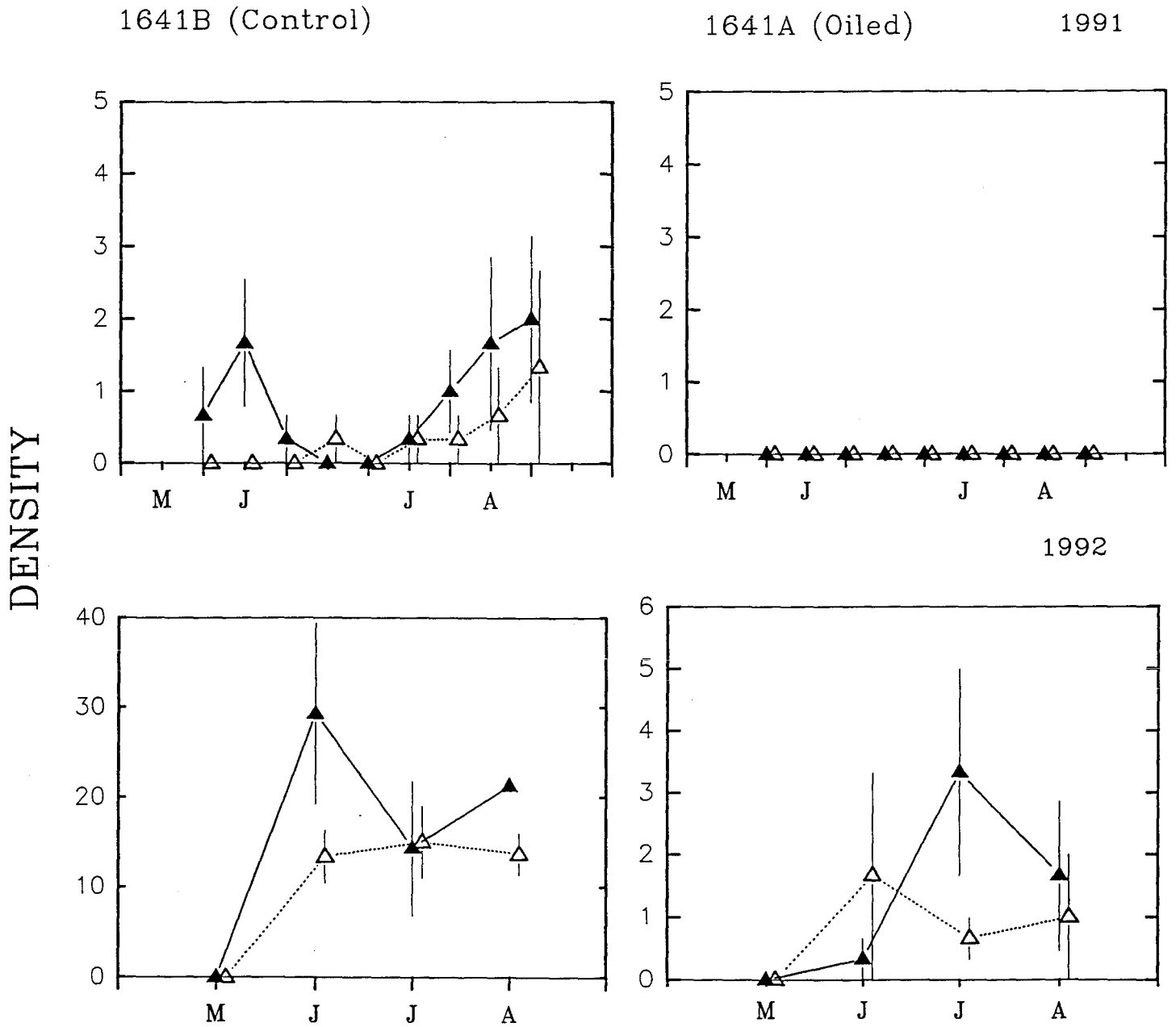

Figure 3.78. Density (No./0.01 m²) of *Fucus* germlings that settled on caged, tarred and scraped vertical rock faces at site pair 1641 during spring-fall 1991-1992. N=3. Layout same as Figure 3.48.

Fucus germlings - caged plots

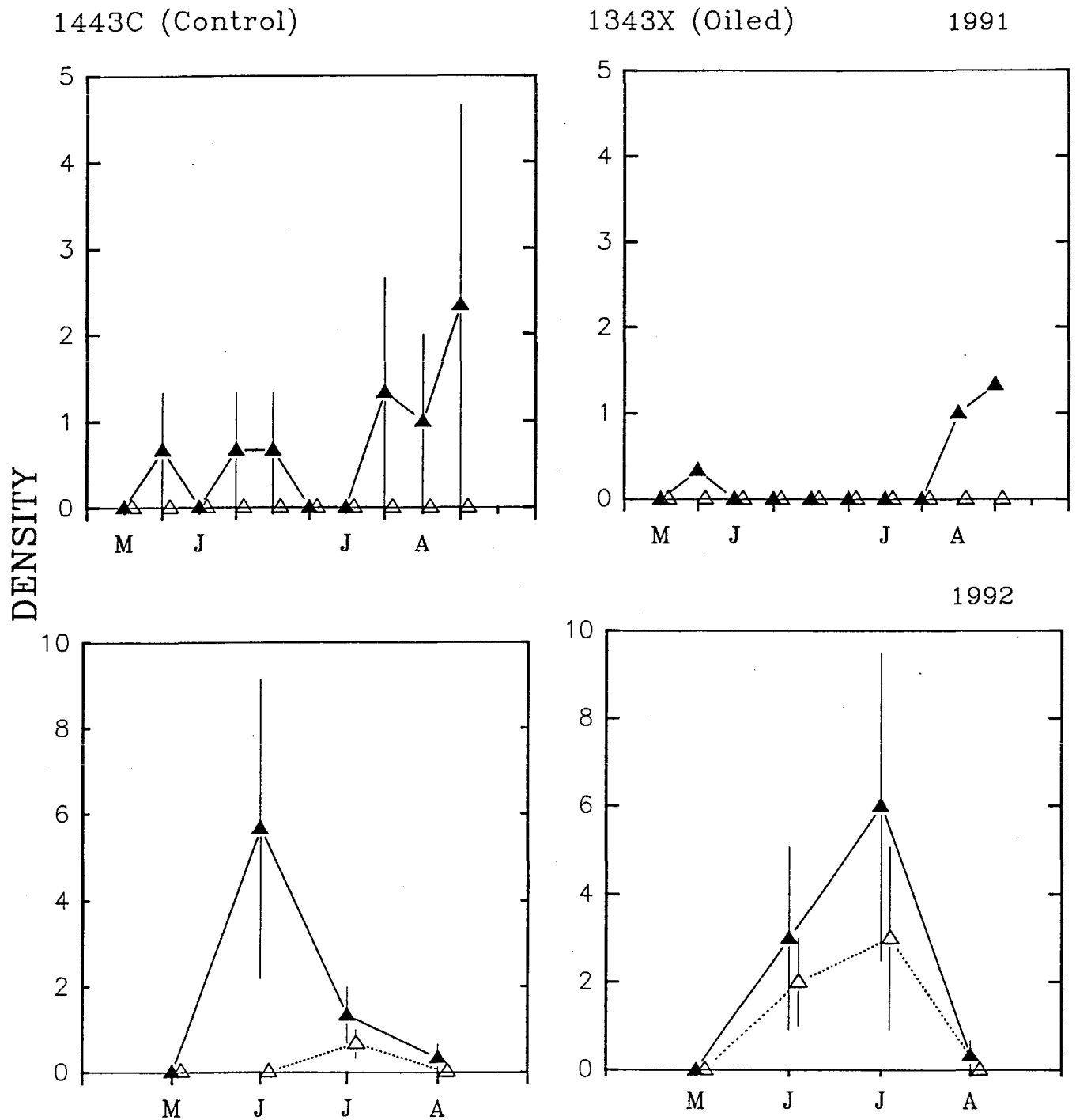

Figure 3.79. Density (No./0.01 m²) of *Fucus* germlings that settled on caged, tarred and scraped vertical rock faces at site pair 1443 during spring-fall 1991-1992. Layout same as Figure 3.48. N=3.

Fucus germlings - caged plots

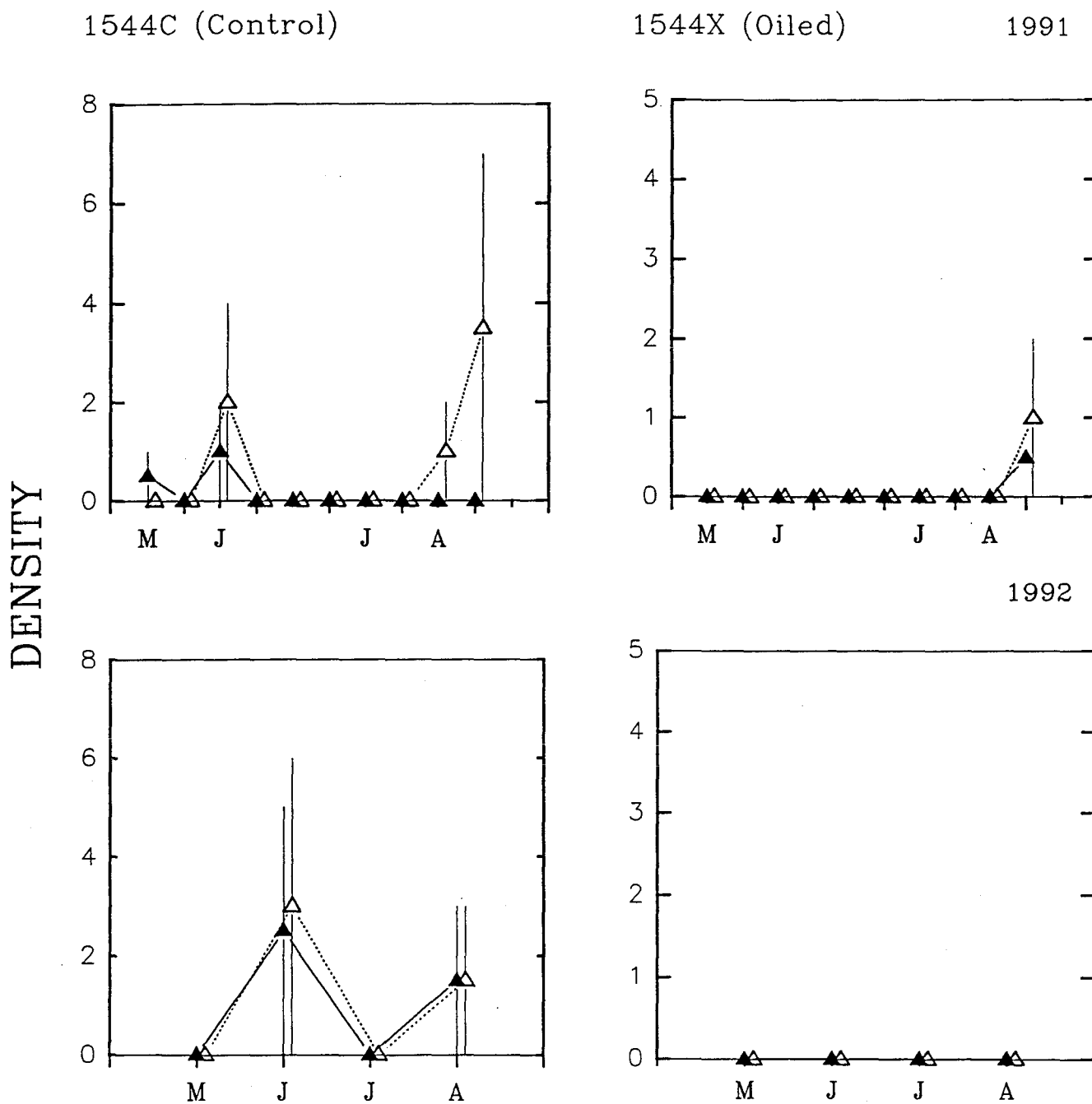

Figure 3.80. Density (No./0.01 m²) of *Fucus* germlings that settled on caged, tarred and scraped vertical rock faces at site pair 1544 during spring-fall 1991-1992. Layout same as Figure 3.48. N=2.

Fucus germlings – caged plots

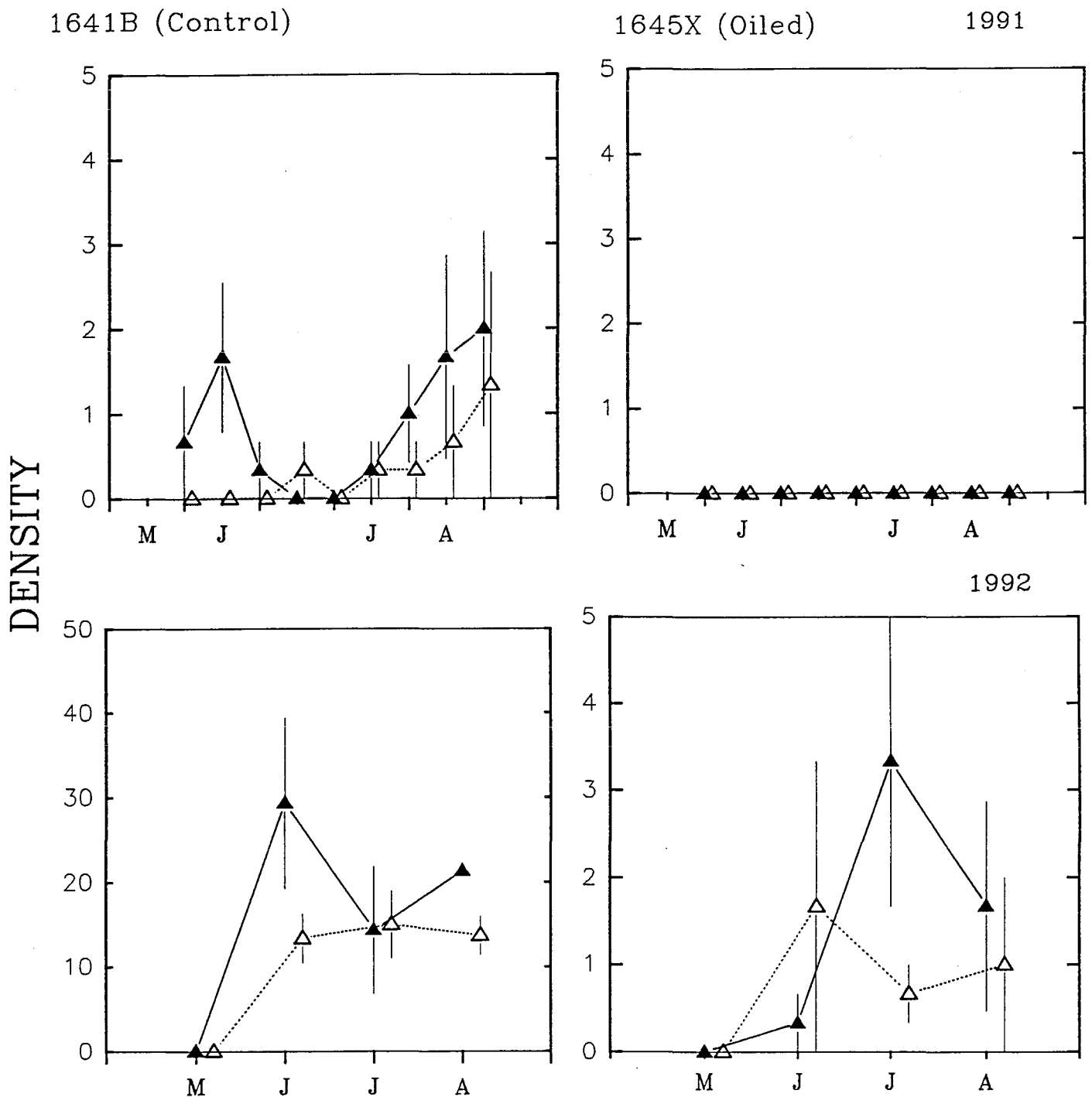

Figure 3.81. Density (No./0.01 m²) of *Fucus* germlings that settled on caged, tarred and scraped vertical rock faces at site pair 1645X during spring-fall 1991-1992. Site 1641B serves as the control match for this pair. Layout same as Figure 3.48. N=3.

Fucus germlings – caged plots

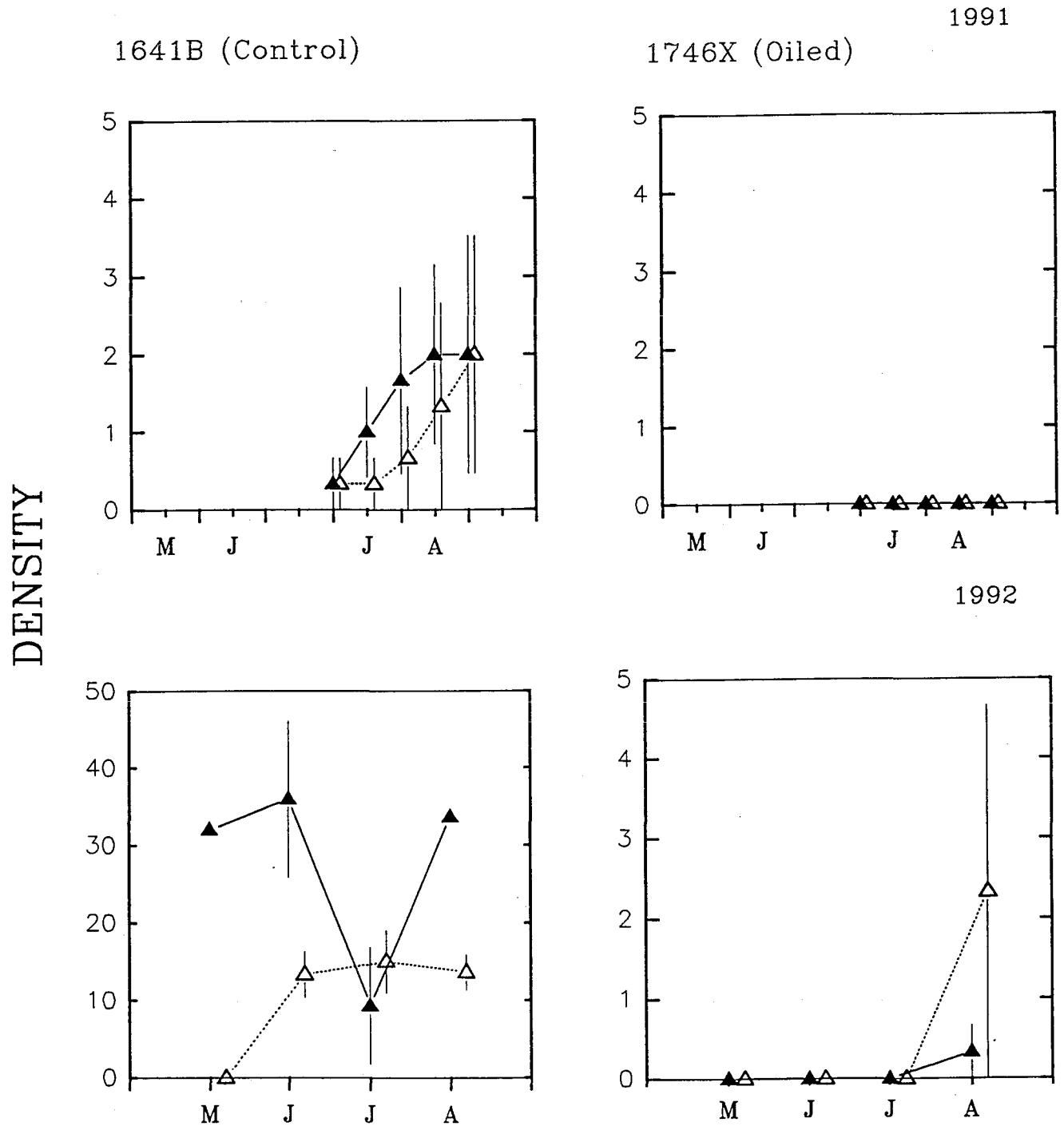
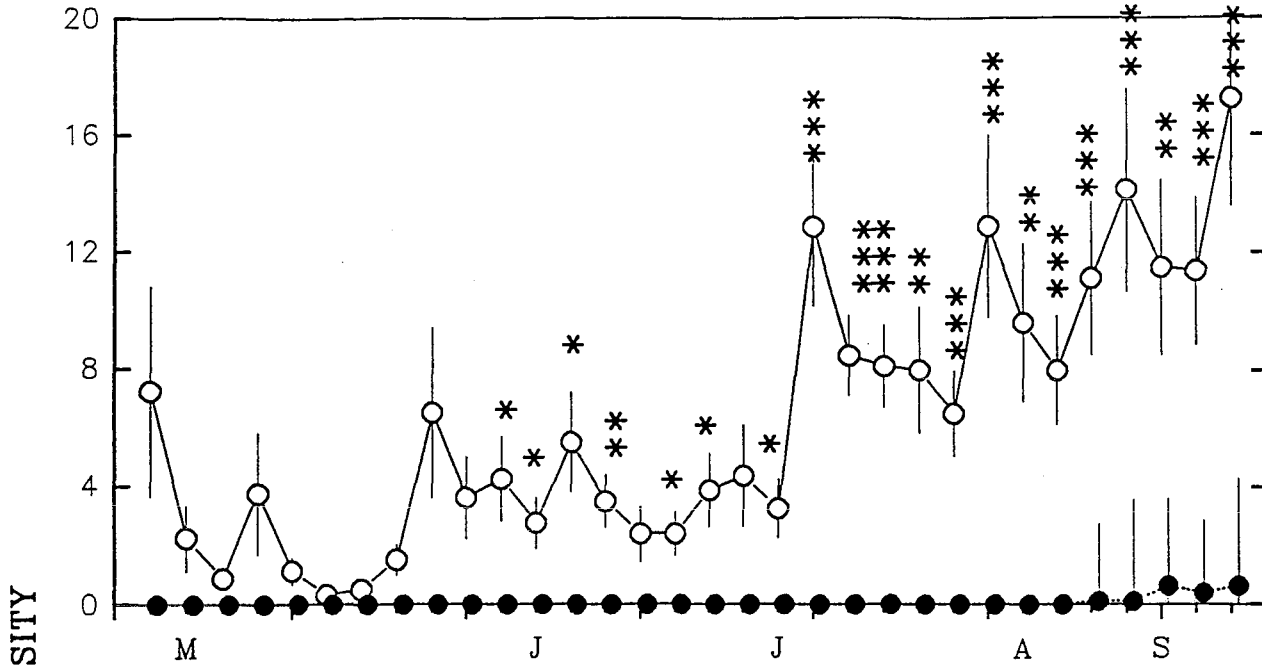

Figure 3.82. Density (No./0.01 m²) of *Fucus* germlings that settled on caged, tarred and scraped vertical rock faces at site pair 1746X during spring-fall 1991-1992. Site 1641B serves as the control match for this pair. Sampling of this site began in July, 1991. Layout same as Figure 3.48. N=3.

Fucus germlings- unscraped plots

1990



Fucus germlings- scraped plots

1990

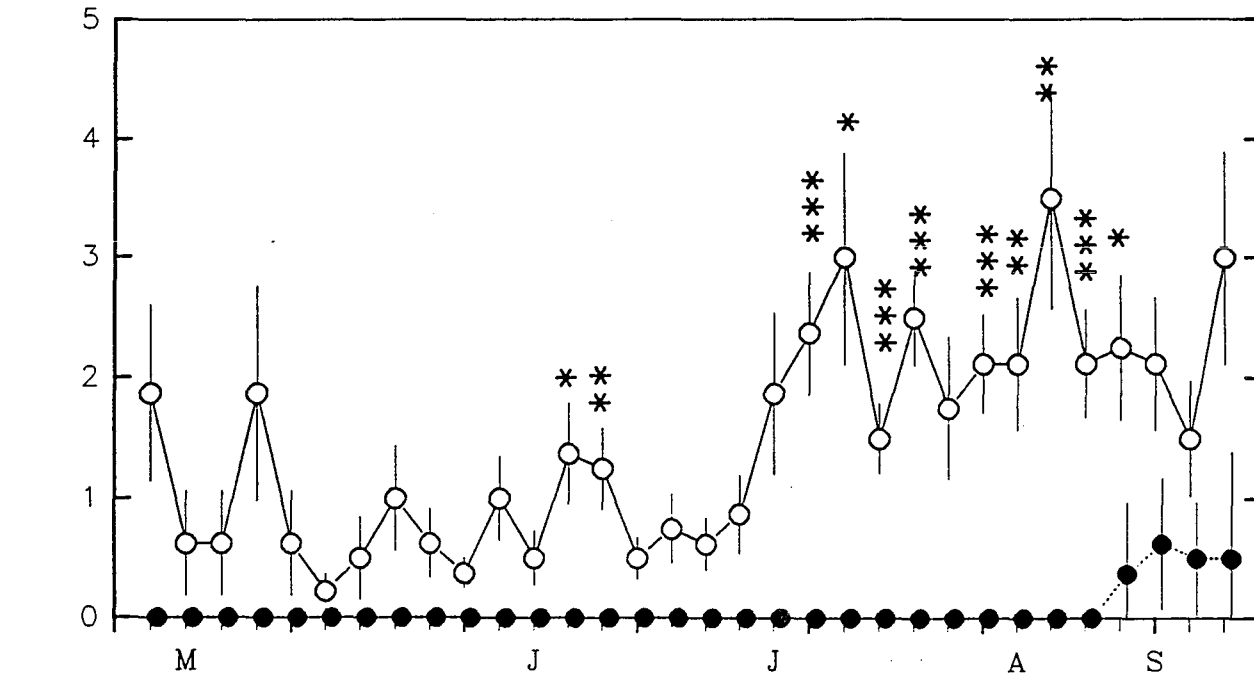

Figure 3.83. Density (No./0.01 m²) of *Fucus* germlings compared between control and oiled sites on unscraped and scraped plots during 1990. All plots were unscraped. Control sites are open circles connected by solid lines. Oiled sites are solid circles connected by dotted lines. Error bars represent plus and minus one standard error of the mean. There were 32 sample dates in 1990 between 5/30 and 9/21. Months are represented by letters on the X-axis. The asterisks represent statistical significance from ANOVA, blocking control and oiled sites (*= $p \leq 0.05$, **= $p \leq 0.025$, ***= $p \leq 0.01$).

Fucus germlings - 1991

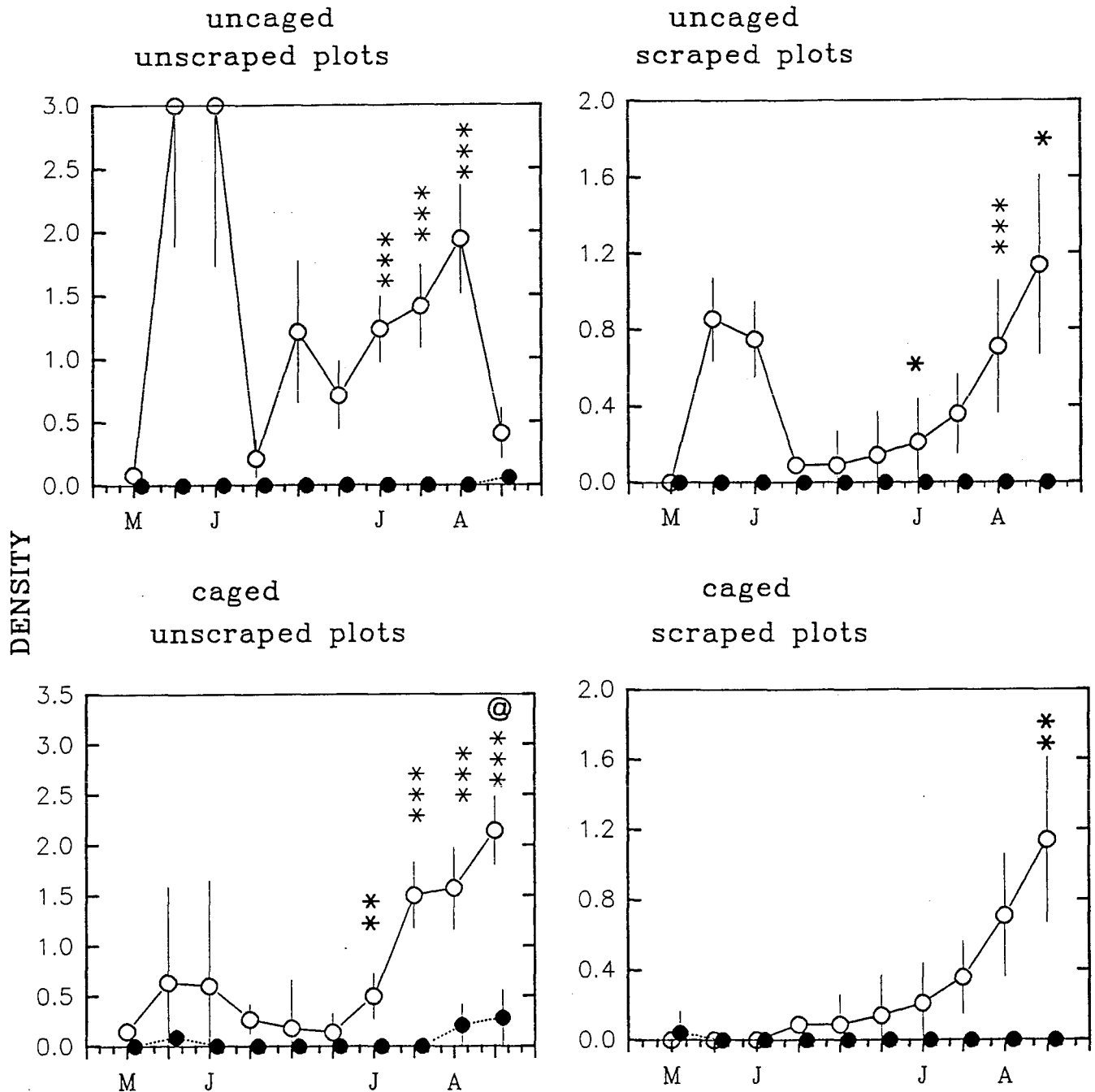

Figure 3.84. Density (No./0.01 m²) of *Fucus* germlings compared between control and oiled sites on unscrapped and scraped plots during 1991. Treatments also include caged and uncaged plots. N=3 for each treatment. Control sites are open circles connected by solid lines. Oiled sites are solid circles connected by dotted lines. Error bars represent plus and minus one standard error of the mean. There were 10 sample dates in 1991 between 4/30 and 8/26. Months are represented by letters on the X-axis. The asterisks represent statistical significance from ANOVA, blocking control and oiled sites (*= $p \leq 0.05$, **= $p \leq 0.025$, ***= $p \leq 0.01$). The @ represents significance ($p \leq 0.05$, ANOVA) between caged and uncaged plots of like treatments.

Fucus germlings - 1992

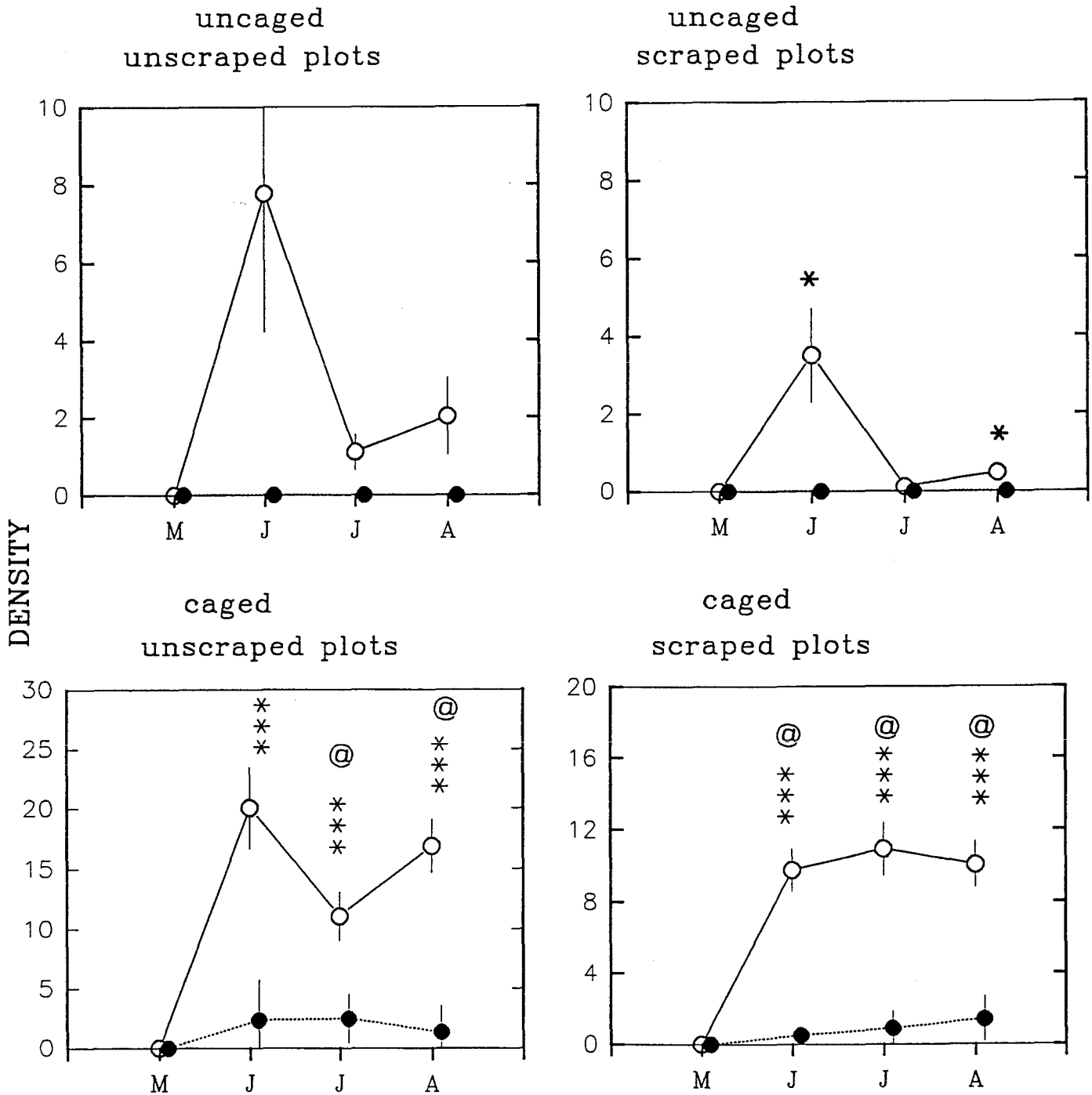

Figure 3.85. Density (No./0.01 m²) of *Fucus* germlings compared between control and oiled sites on unscraped and scraped plots during 1992. Treatments also included caged and uncaged plots. N=3 for each treatment. Control sites are open circles connected by solid lines. Oiled sites are solid circles connected by dotted lines. There were 4 sample dates in 1992 between 5/31 and 8/27. Months are represented by letters on the X-axis. The asterisks represent statistical significance from ANOVA, blocking control and oiled sites (*=p≤0.05, **=p≤0.025, ***=p≤0.01). The @ represents significance (p≤0.05) between caged and uncaged plots of like treatments.

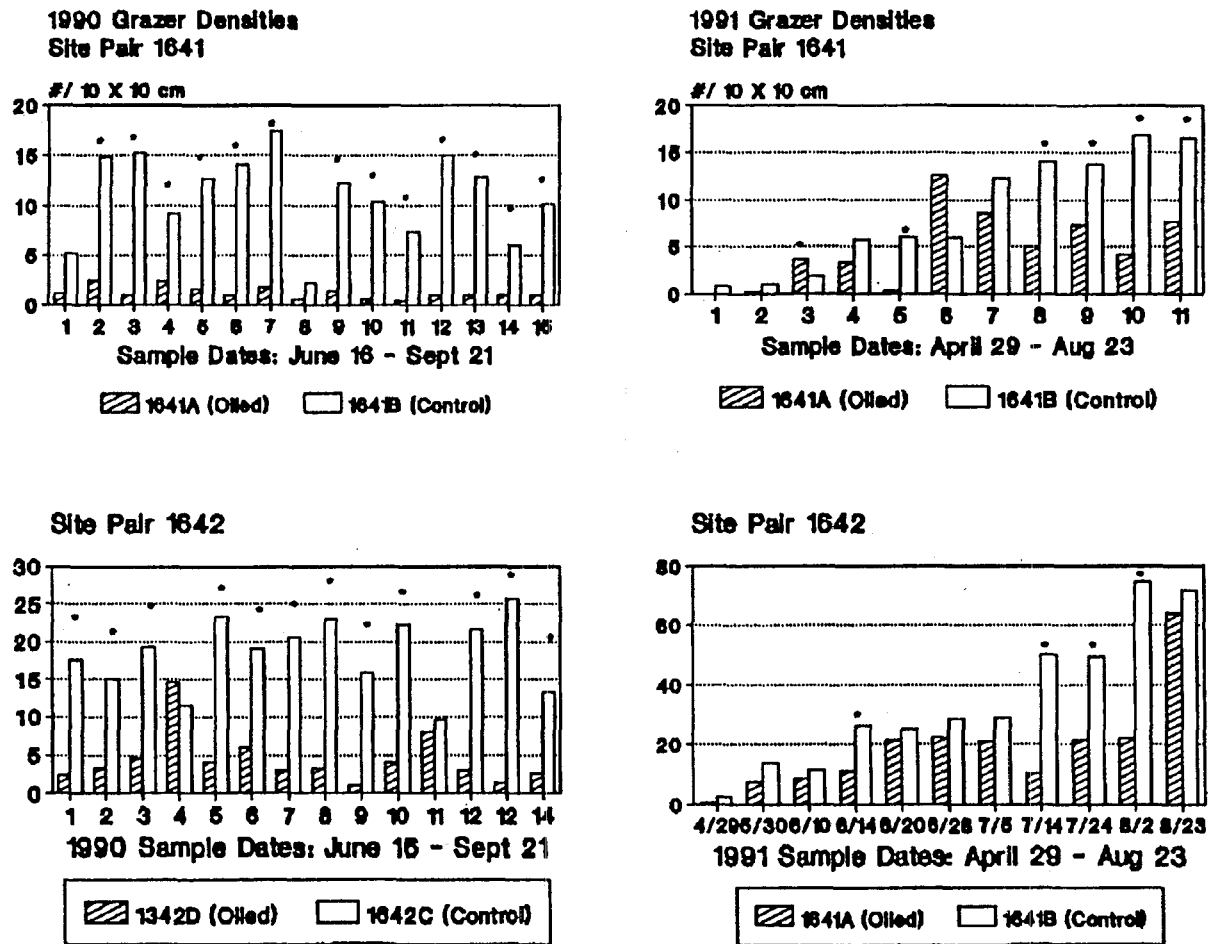

Figure 3.86. Density (No./0.01 m²) of grazers (limpets and littorines) compared between oiled and control plots. The '*' represents significance ($p \leq 0.05$ -ANOVA). Sites 1641 and 1642 were sampled in 1990 and 1991. All other sites were sampled only in 1991. Site 1641B served as the control for oiled sites 1645X and 1746X. Note scale differences.

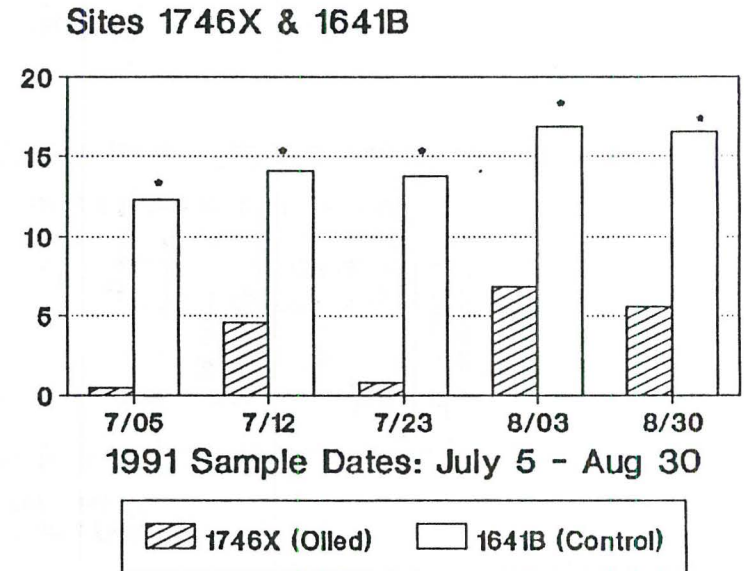
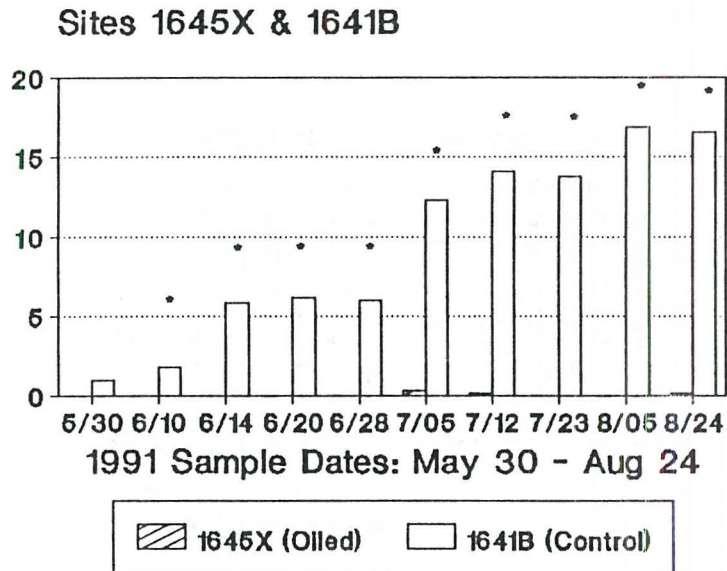
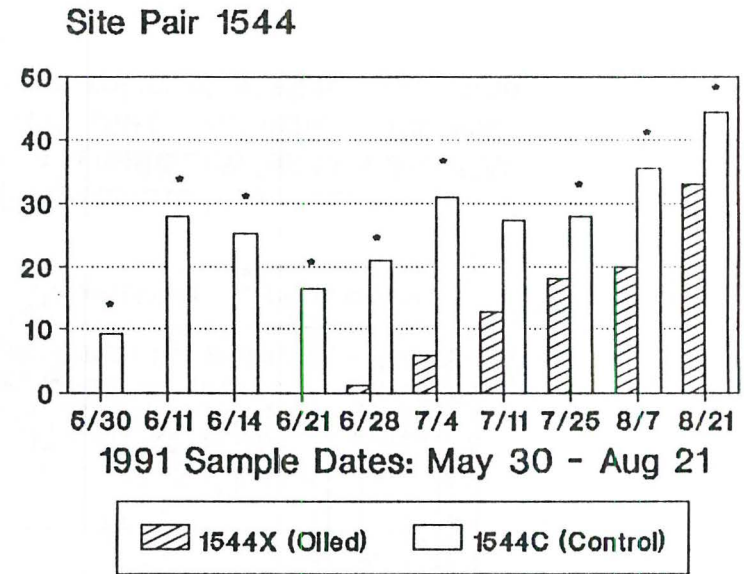
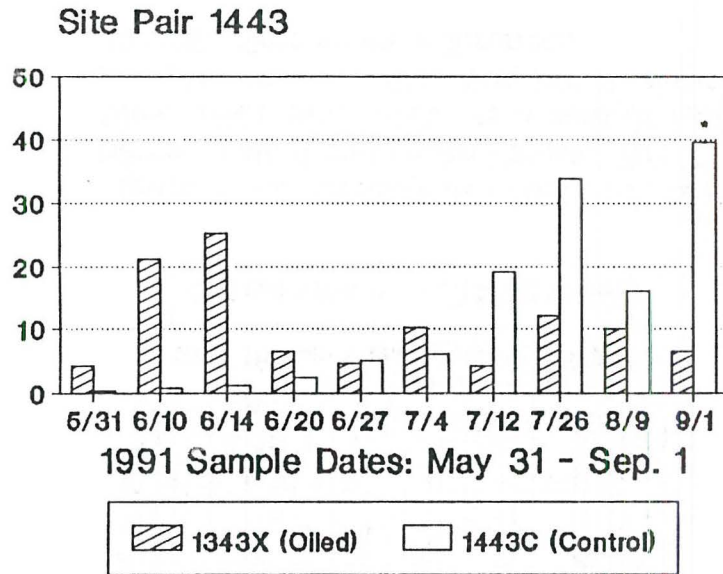
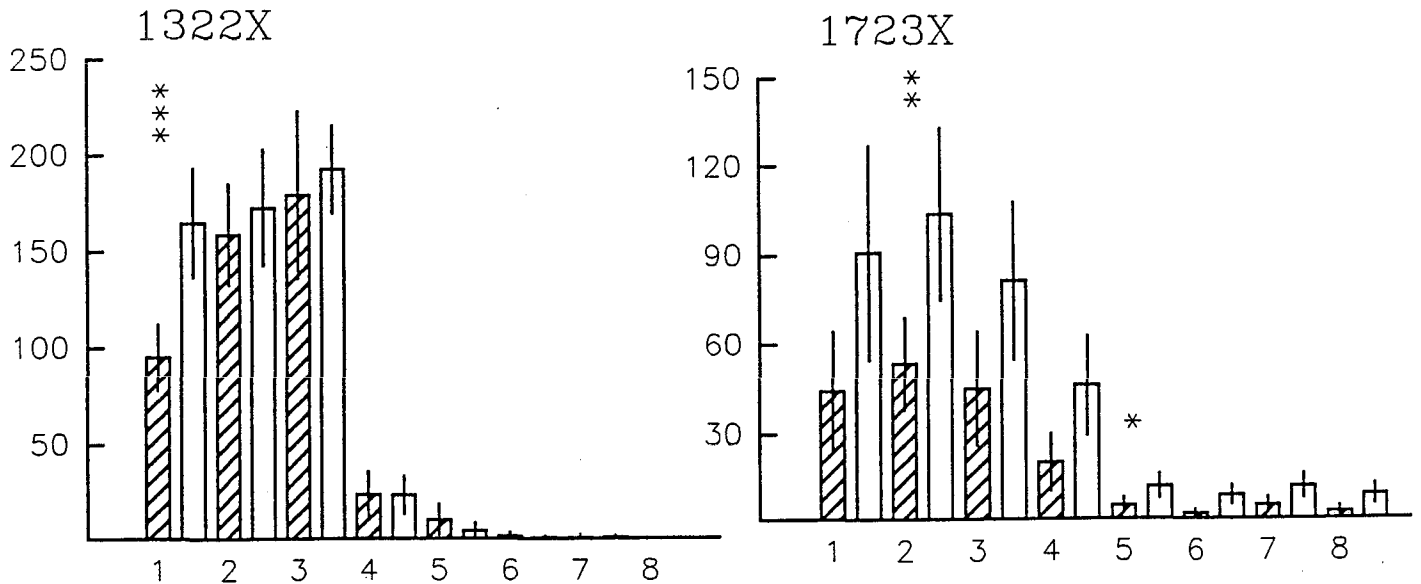

Figure 3.87. Density (No./0.01 m²) of grazers (limpets and littorines) in 1991 compared between oiled and control plots. The '*' represents significance ($p \leq 0.05$ -ANOVA). Site 1641B served as the control for oiled sites 1645X and 1746X.

"EV" Rocks



"PB" Rocks

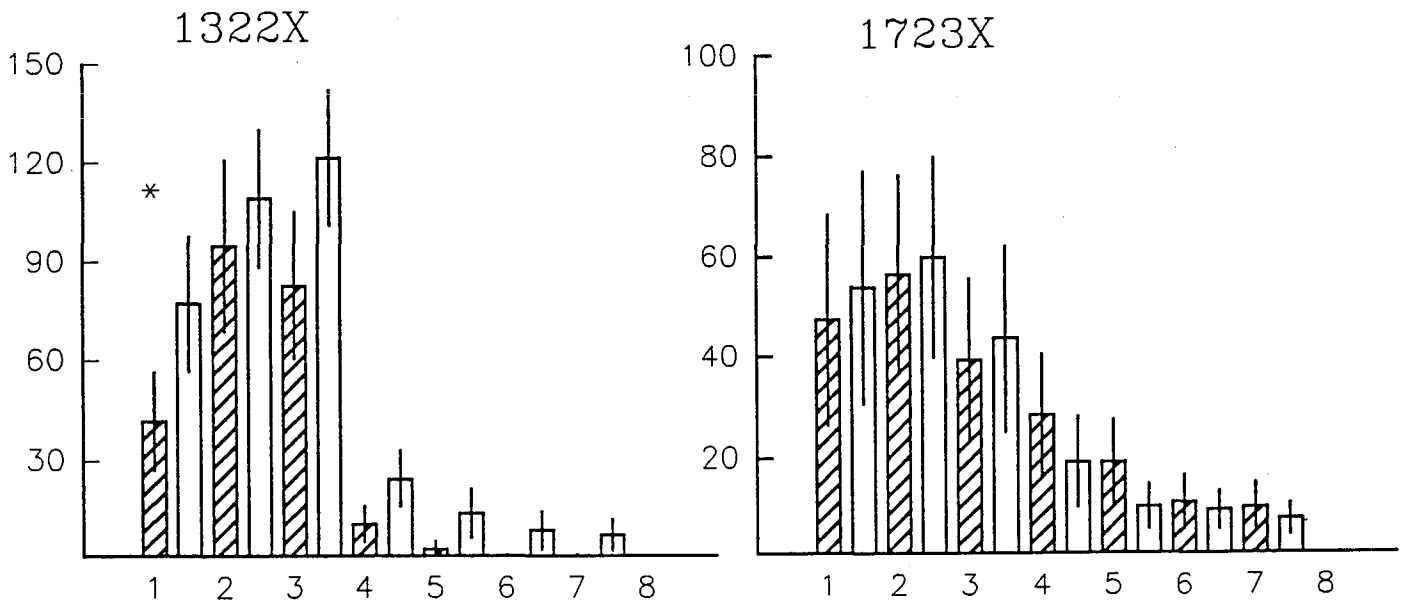
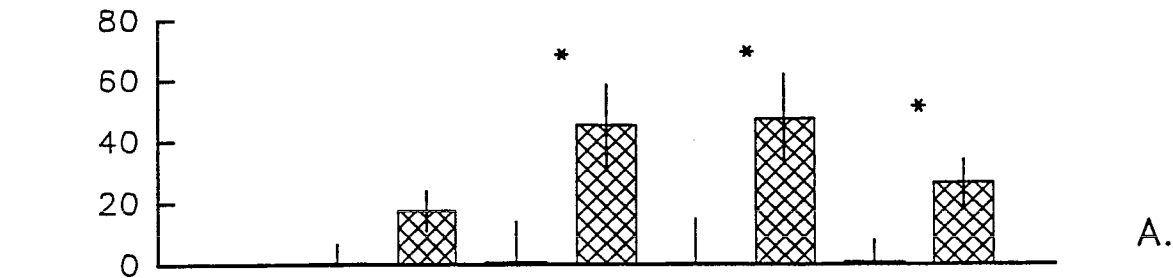
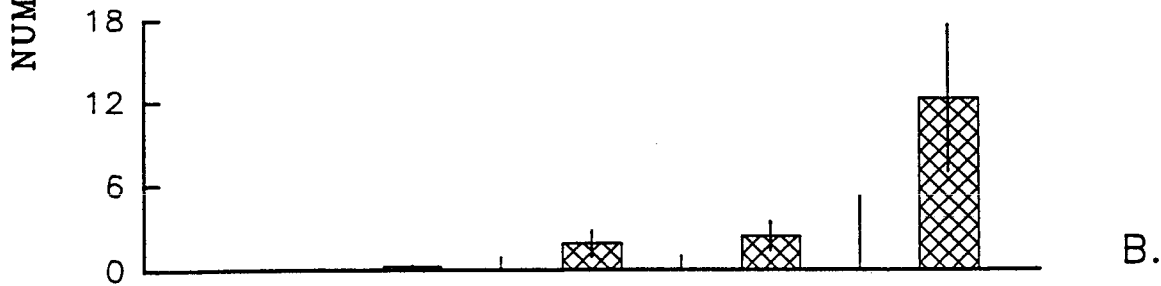

Figure 3.88. Barnacle recruitment on oiled and non-oiled halves of rocks placed at two of six study sites in 1990. Only the oiled sites 1322X and 1723X were heavily colonized in 1990. 'EV' represents rocks coated with *in-situ* oil from the T/V EXXON VALDEZ. 'PB' rocks represent those coated with Pruhoe Bay crude oil in 1990. Sample dates 1-8 represent approximately weekly sampling from 3 July to 20 September 1990.

Fucus germlings - unoiled tiles



Fucus germlings - oiled tiles



% algal cover - unoiled tiles

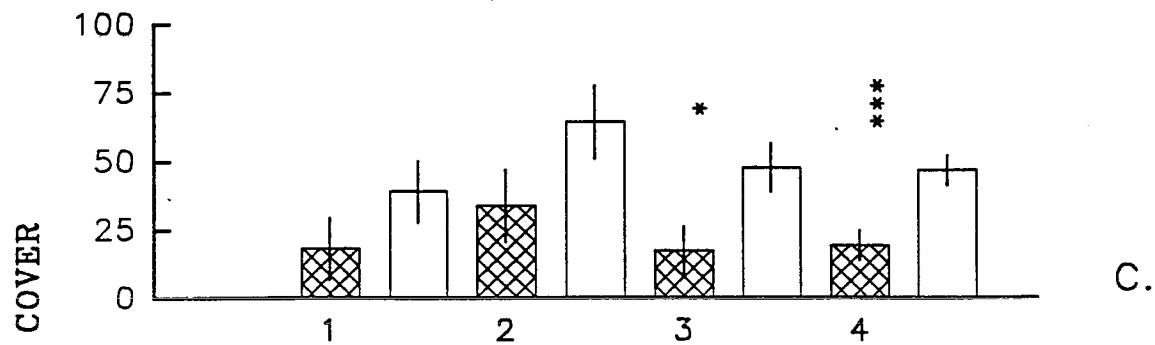

% algal cover - oiled tiles



Figure 3.89. A. Mean density for *Fucus* germlings on unoiled tiles in caged (cross-hatched bars) and uncaged (open bars) plots. N=6 for each sample date. Sample dates 1-4 were 6/30, 7/1, 7/31 and 8/29, 1992. B. Mean density for *Fucus* germlings on oiled tiles in caged and uncaged plots. C. Mean percent cover of filamentous algae on unoiled tiles in caged (cross-hatched bars) and uncaged (open bars) plots. D. Mean percent cover for filamentous algae on oiled tiles in caged and uncaged plots. *= $p \leq 0.05$; ***= $p \leq 0.01$, ANOVA.

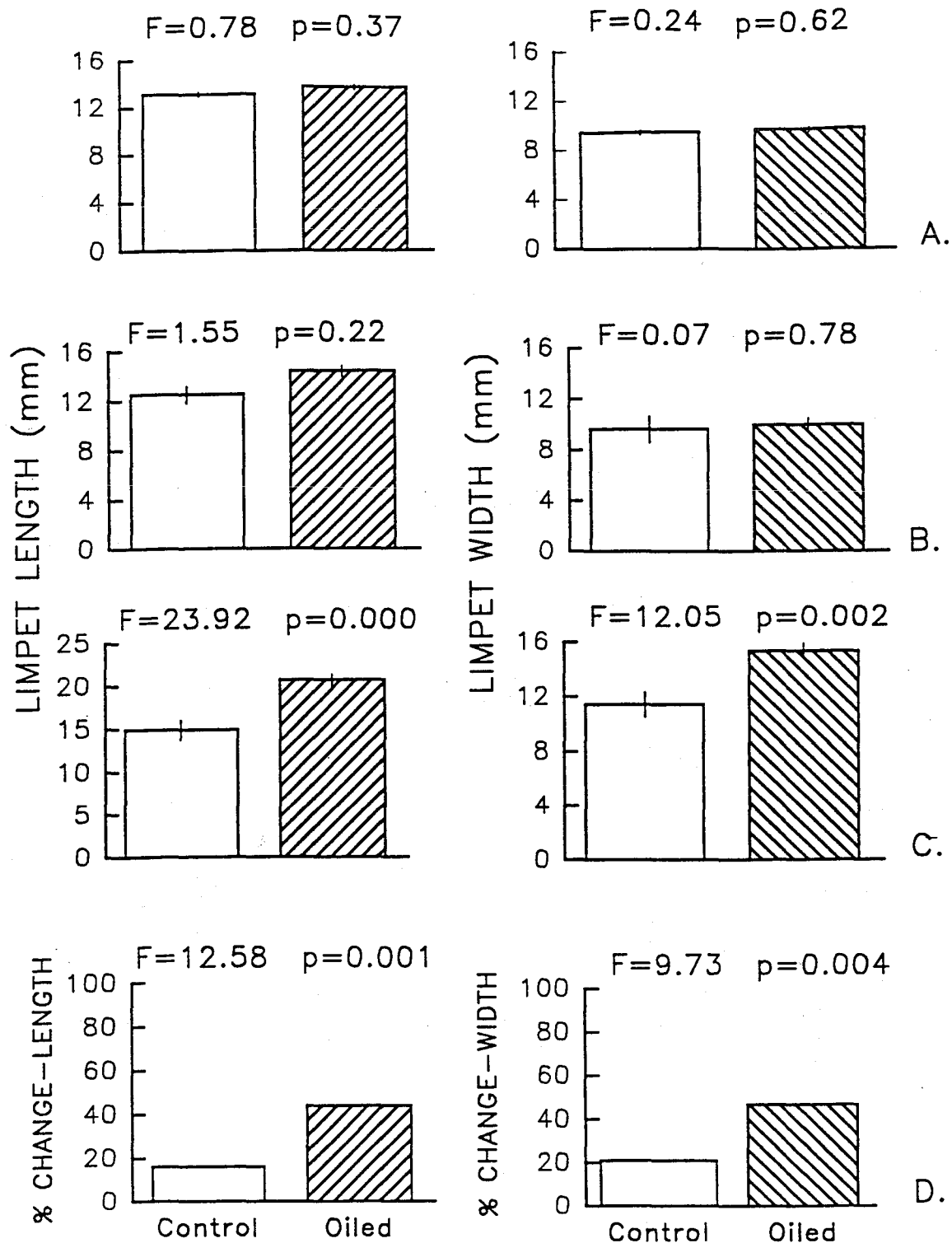

Figure 3.90. Mean lengths and widths of limpets tagged at control and oiled sites as part of the limpet- *Fucus* canopy retained/removed study. A. Mean lengths (left) and widths (right) for all limpets at study beginning in 1991. N=226 for control sites (open bars); N=230 for oiled sites (hatched bars). ANOVA F-ratios and probabilities are listed above each histogram. B. Mean start limpet lengths and widths (1991) for limpets recaptured in 1992 (N=7 for control; N=21 for oiled). C. Mean limpet length and width of recaptured limpets after 1 yr. D. Percent change in limpet length and width at control and oiled sites.

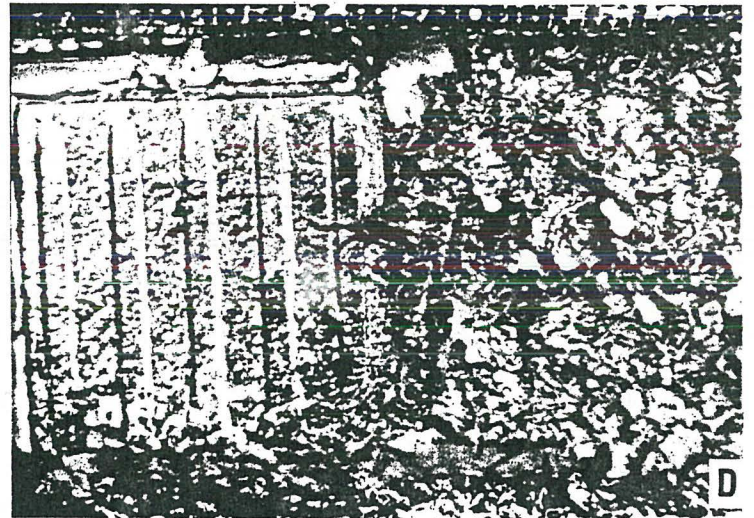
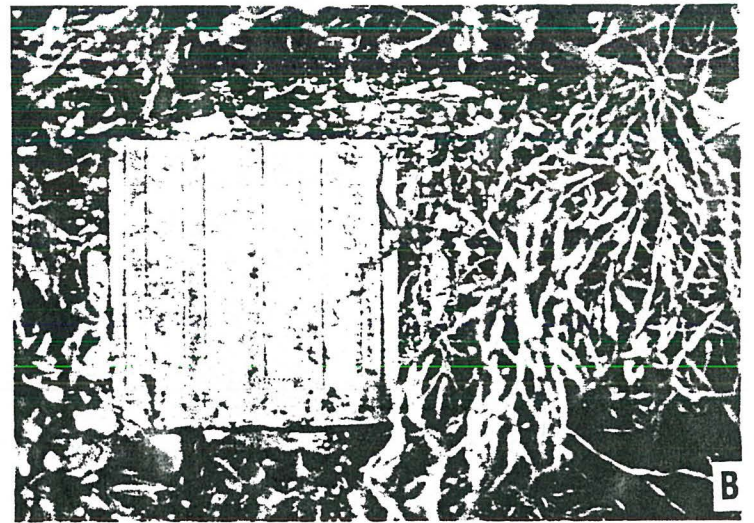
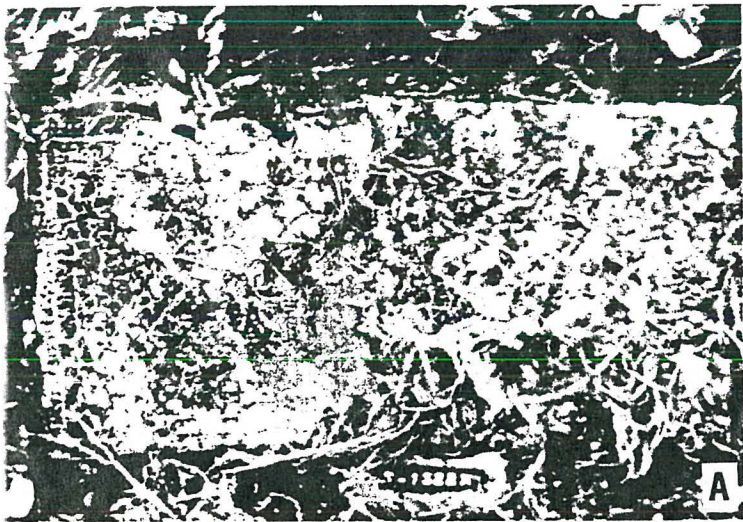

Figure 3.91. Examples of percent algal cover on oiled and non-oiled tile pairs. Photographs were taken in 1992. Pair A represents a ceramic tile pair placed in 1990. Pair B is an uncaged clay tile pair placed in 1991. Pair C is a caged tile pair also placed in 1991. Pairs A-C are from site 1322X. Pair D, placed in 1991, is a caged tile pair from site 1723X. The differences seen in these photographs were not consistently obvious at control sites.

Table 3.1. Repeated measures ANOVA on mean densities (No./0.1 m²) of the limpets, *Tectura persona* and *Lottia pelta*. P-values listed are for differences between control and oiled site pairs over six sample periods between 1990-1992. "MVD" refers to meter of vertical drop below Mean High High Water. For the "Recovery?" column: "Yes" = oiled site population has equaled or exceeded the matched control site; "No" = oiled site population has not shown a temporal increase; "Maybe" = control site population remains greater, but a rise in the oiled site population has been observed in 1992. "-" = no significant difference in density was observed between the site pair over time. "*" = sites established in 1991. All other sites were established in 1990. "+" = oiled site of the pair is matched to existing control site, 2333C.

Pair	MVD	<i>Tectura persona</i> Repeated Measures ANOVA						<i>Lottia pelta</i> Repeated Measures ANOVA					
		Control Mean	Oiled Mean	p-Values		Date*	Recovery?	Control Mean	Oiled Mean	p-Values		Date*	Recovery?
				Site	Date					Site	Date		
1231	1	6.13	1.44	0.02	0.005	0.13	No	3.02	2.25	0.71	0.49	0.37	-
	2	4.83	1.47	0.005	0.19	0.36	No	15.61	10	0.01	0.004	0.12	Maybe
	3	0.83	0.25	0.03	0.02	0.06	No	16.3	5.19	0.004	0.0003	0.04	No
1732	1	6.44	1.11	0.04	0.0001	0.023	No	3.38	2.08	0.51	0.01	0.87	-
	2	3.83	0.63	0.08	0.33	0.53	No	6.63	8.02	0.66	0.0002	0.98	-
	3	0	0.63	0.06	0.56	0.033	-	1.8	4.3	0.26	0.1	0.61	-
2333	1	8.02	1.16	0.02	0	0.5	No	0.77	0.03	0.005	0	0	No
	2	8.02	1.88	0.0001	0	0.0005	No	2.88	0.55	0.006	0.02	0.01	No
	3	3.69	0.77	0.04	0.14	0.39	No	6.19	3.83	0.38	0	0.2	Yes
2834	1	8.27	4.11	0.02	0.0002	0.94	No	0.66	0.3	0.31	0.2	0.23	-
	2	10.6	8.25	0.2	0	0.55	Yes	2.66	3.52	0.54	0.003	0.24	Yes
	3	3.13	5.58	0.23	0.01	0.32	Yes	6.4	11.4	0.02	0	0.04	Yes
3811	1	1.77	0	0.03	0.02	0.02	No	1.72	0.94	0.35	0.002	0.92	-
	2	0.55	0	0.007	0.003	0.003	No	5.08	2	0.21	0.0002	0.75	-
	3	1.91	0.16	0.05	0.19	0.3	No	8.02	0.72	0.12	0.005	0.04	No
2337**	1	8.7	5.6	0.29	0	0.015	Yes	0.8	0.63	0.15	0.45	0.49	-
	2	9.7	12.6	0.25	0.02	0.1	-	2.8	6.6	0.04	0.22	0.93	-
	3	4.13	2	0.21	0.35	0.73	Maybe	6.6	10.8	0.36		0.56	-
1852*	1	5.37	5.83	0.88	0.004	0.43	-	3.75	1.16	0.08	0.98	0.04	Maybe
	2	2.16	0.88	0.3	0.37	0.09	Maybe	6	6.95	0.74	0.12	0.42	-
	3	0.2	0.13	0.66	0.26	0.91	-	7.7	3.2	0.21	0.004	0.36	-

Table 3.2.

Repeated measures ANOVA on mean densities (No./0.1m²) of the periwinkle, *Littorina sitkana*. "MVD" refers to meter of vertical drop below Mean High High Water. P-values listed are for differences between control and oiled site pairs over six sample periods between 1990-1992. For the "Recovery?" column: "Yes" = oiled site population has equaled or exceeded the matched control site; "No" = oiled site population has not shown a temporal increase; "Maybe" = control site population remains greater, but a rise in the oiled site population has been observed in 1992. "-" = no significant difference in density was observed between the site pair over time. "*" = sites established in 1991. All other sites were established in 1990. "+" = oiled site of the pair is matched to existing control site, 2333C.

<i>Littorina sitkana</i>		Repeated Measures ANOVA					
Pair	MVD	Control	Oiled	P-values			Recovery?
		Mean	Mean	Site	Date	Date*Site	
1231	1	30.63	29.86	0.94	0.000	0.06	-
	2	23.97	10.53	0.03	0.0005	0.036	No
	3	6.20	0.64	0.035	0.0031	0.01	No
1732	1	8.53	18.22	0.28	0.0009	0.25	-
	2	10.11	6.5	0.48	0.048	0.67	-
	3	1.28	4.71	0.267	0.122	0.169	-
2333	1	12.17	5.61	0.01	0.000	0.12	No
	2	16.53	4.58	0.00	0.03	0.375	No
	3	6.36	10.31	0.25	0.0065	0.169	-
2834	1	5.34	5.14	0.27	0.0049	0.022	-
	2	9.36	12.78	0.4	0.03	0.06	-
	3	9.77	10.06	0.88	0.003	0.51	-
3811	1	17.94	0.5	0.005	0.0003	0.0005	No
	2	7.03	0.61	0.014	0.011	0.044	No
	3	3.44	0	0.044	0.103	0.103	No
2337**	1	13.58	23.29	0.09	0.0071	0.389	-
	2	17.67	22.46	0.42	0.0037	0.0018	-
	3	7.63	34.67	0.0016	0.0015	0.017	-
1852*	1	33.71	9.33	0.08	0.63	0.17	No
	2	35.67	8.33	0.0013	0.000	0.0072	No
	3	4.17	4.17	1.000	0.0058	0.305	-

Table 3.3. Ultraviolet Fluorescence Indices for sediment hydrocarbon samples taken in Herring Bay at matched oiled and control sites in 1990 and 1991. The larger the number, the greater the concentration of petroleum hydrocarbons. Sites followed by the letter 'C' are controls; 'X' denotes oiled sites. 'NO SEDIMENT' means sediment was not available at a matched site. 'MVD' refers to meter of vertical drop below Mean High High Water.

Control Site	MVD	U/V Index	Oiled Site	MVD	U/V Index
1990					
1222C	1	-0.5	1322X	NO SEDIMENT	
	2	-0.2		2	130
	3	1		3	160
1251C	2	-0.2	1251X	2	500
	3	0.7		3	23
1411C	1	0	1311X	1	1000
	2	-1		2	600
	3	-0.5		3	300
1312C	1	30	1312X	1	300
	2	1		2	80
	3	-1		3	190
1723C	1	1.6	1723X	1	100
	2	2		2	150
	3	3		3	130
1852C	2	-2	1852X	1	80
				2	0
				3	190
1991					
1221C	2	0.20	1221X	NO SEDIMENT	
	3	0.10			
1222C	1	3	1322X	NO SEDIMENT	
	2	0			
	3	-1.60			
1312C	2	0	1312X	NO SEDIMENT	
	3	6			
1231C	NO SEDIMENT		1231X	1	90
1251C	NO SEDIMENT		1251X	1	94
				2	100
				3	80
1411C	2	3	1311X	NO SEDIMENT	
1713C	1	0.80	1713X	2	70
				3	50
1723C	1	1	1723X	1	450
	2	37			
	3	0			
1852C	1	14	1852X	NO SEDIMENT	
	2	50			
	3	3			

Table 3.4. Mean Ultraviolet Fluorescence Indices for oiled and control site sediments for 1990 and 1991. 'MVD' refers to meter of vertical drop.

MVD	N	Mean	Standard Deviation	N	Mean	Standard Deviation
Control Sites: 1990				Oiled Sites: 1990		
1	4	7.775	14.84371	4	370	431.58
2	6	-.07	1.4179	6	243.33	245.16
3	5	.64	1.556599	6	165.5	90.42
Control Sites: 1991				Oiled Sites: 1991		
1	4	4.7	6.28	3	211.33	206.70
2	5	18.04	23.72	2	85	21.21
3	6	1.25	2.76	2	65	21.21

Table 3.5. Mean number of barnacle recruits and paired t-test results for tile pairs in 1991. Tile pairs were separated into 3 treatments. Three pairs of tarred and clean tiles were caged and 3 pairs were uncaged. Three tile pairs consisted of one clean and one painted black tile. N = 3 for each treatment. Sites ending with "C" are control sites; "X" denotes oiled sites.

Date	Site	Caged Tiles				Uncaged Tiles				Painted Tiles										
		Clean	Std	Oiled	Std	t-val	p-val	Clean	Std	Oiled	Std	t-val	p-val	Clean	Std	Paint	Std	t-val	p-val	
6/23/91	1221C	0		0				0		0			0		0					
	1221X	0		0				0		0			0		0					
	1222C	0		0				0		0			0		0					
	1322X	0		0				0		0			0		0					
	1723C	0		0				0		0			0		0					
	1723X	0		0				0		0			0		0					
7/03/91	1221C	0		0				0		0			0		0					
	1221X	0		0				0		0			0		0					
	1222C	0.33	0.57	0		1.0	0.42	0		0			0.16	0.4	0			1.0	0.36	
	1322X	22.6	22.0	0		1.78	0.21	2	1.73	0	2.0	0.18	23.3	36.9	32	45.3	1.66	0.23		
	1723C	0		0				0		0			0		0					
	1723X	0.33	0.57	0		1.0	0.42	0		0			0		0					
7/15/91	1221C	3.33	1.52	0		3.77	0.06	0		0			0.5	1	0			1.0	0.39	
	1221X	0.33	0.57	0		1.0	0.42	0		0			0		0					
	1222C	1.66	2.88	0		1.0	0.42	1.66	1.15	0	2.5	0.13	1	1.09	0			2.23	0.08	
	1322X	38.6	49.5	5	7.8	1.39	0.29	257.3	370.7	36	43.3	1.16	0.36	393	679.8	316.3	541	0.95	0.44	
	1723C	0		0				0.33	0.57	0			0		0					
	1723X	6.66	9.07	1.66	2.88	0.83	0.49	0.66	0.57	0	2.0	0.18	2	2	1.33	2.3	1.0	0.42		
7/26/91	1221C	3.66	1.15	0		5.5	0.03	0		0			0		0					
	1221X	1.33	1.15	0		2.0	0.18	0		0			0.66	1.15	1	1	1.0	0.42		
	1222C	0.66	1.15	0		1.0	0.42	3.66	3.05	0	2.0	0.17	2	2.68	0.16	0.4	1.61	0.16		
	1322X	296	189.0	216.6	90.4	1.38	0.3	1066.6	144.5	517.3	254.2	6.4	0.02	829.3	460	933.6	379	0.62	0.59	
	1723C	0.33	0.57	0		1.0	0.42	0.66	0.57	0			0		0					
	1723X	344.3	296.4	315	278	1.85	0.2	857.3	590	432.6	109.6	1.43	0.28	476.6	409.5	442.3	516.4	0.19	0.86	

Table 3.5. (Continued)

		Caged Tiles						Uncaged Tiles						Painted Tiles					
Date	Site	Clean	Std	Oiled	Std	t-val	p-val	Clean	Std	Oiled	Std	t-val	p-val	Clean	Std	Paint	Std	t-val	p-val
8/06/91	1221C	1.33	1.15	0		2.0	0.18	0		0				0		0			
	1221X	1	1	0		1.73	0.22	0		0				4	6.9	2	3.46	1.0	0.42
	1222C	1.66	0.57	0		5.0	0.03	6.66	9.86	0		1.27	0.36	3.33	7.22	0		1.13	0.31
	1322X	121.3	18.14	158.6	149.7	0.39	0.73	214.6	125.1	225.3	221.6	0.08	0.94	415.6	444.7	555.3	469.5	1.59	0.25
	1723C	1.66	2.88	0		1.0	0.42	0		0				0		0			
	1723X	3.66	4.72	5.66	7.37	0.37	0.74	68	31.5	60.3	6.43	0.4	0.72	79	121.3	28.3	35.4	1.02	0.41
8/23/91	1221C	0.66	0.57	0		2.0	0.18	0		0				0.33	0.57	0		1.0	0.42
	1221X	0		0				0		0				0.33	0.57	0		1.0	0.42
	1222C	0		0				0		0				0		0			
	1322X	15.33	11.01	7.3	5.03	0.98	0.42	108.6	75.1	26	36.4	2.13	0.16	102	117.3	216	253.9	1.44	0.28
	1723C	0		0				0		0				0		0			
	1723X	46.6	50.2	94	75.9	2.67	0.11	208.66	267	166.66	188.3	0.88	0.47	52	70.4	95.6	156.2	0.38	0.73

Table 3.6. Mean number of barnacle recruits and paired t-test results for tile pairs in 1992. Tile pairs were separated into 3 treatments. Three pairs of tarred and clean tiles were caged and 3 pairs were uncaged. Three tile pairs consisted of one clean and one painted black tile. N = 3 for each treatment. Sites ending with "C" are control sites; "X" denotes oiled sites.

Barnacle Juveniles		Caged Tiles						Uncaged Tiles						Painted Tiles					
Date	Site	Clean	Std	Oiled	Std	t-val	p-val	Clean	Std	Oiled	Std	t-val	p-val	Clean	Std	Paint	Std	t-val	p-val
6/03/92	1221C	0		0				0		0				0		0			
	1221X	0		0				0		0				0		0			
	1222C	0		1.66	2.88	1.0	0.42	6	2.0	3.33	4.16	0.75	0.52	0		4.66	8.08	1.0	0.42
	1322X	0		6.66	11.54	1.0	0.42	0		0				0.66	1.15	0		1.0	0.42
	1723C	0		0				0		0				0		0			
	1723X	0		0				0		0				0		0			
7/01/92	1221C	0		0				0		0				0		0			
	1221X	0		0				0		0				0		0			
	1222C	0		0				0		0				0		0			
	1322X	0.66	1.15	0.33	0.57	0.37	0.74	0		0				0.33	0.57	0		1.0	0.42
	1723C	0		0				0		0				0		0			
	1723X	0.33		0.66		0.37	0.74	5.33	9.23	4.66	8.08	1.0	0.42	0		0			
7/31/92	1221C	0		0.33	0.57	1.0	0.42	0		0				0		0			
	1221X	0		0.33	0.57	1.0	0.42	0		0				0		0			
	1222C	0		0				0		0				0		0			
	1322X	4.66	7.23	38.66	41.79	1.65	0.23	0		0				64	110.8	15.66	27.13	1.0	0.42
	1723C	0		0				0		0				0		0			
	1723X	0		0				1.33	2.31	64.33	111.4	1.0	0.42	1	1.73	0.66	1.15	0.23	0.84
8/28/92	1221C	0.33	0.57	1.66	2.88	0.71	0.54	0		0				0		0			
	1221X	0		0.66	1.15	1.0	0.42	0		0				0		0			
	1222C	0		0				0		1.33	1.52	1.51	0.26	0		0			
	1322X	0		5	5.29	1.63	0.24	0		0				26.33	41.35	12.66	11.01	0.66	0.57
	1723C	0		0				0		0				0		0			
	1723X	0.33	0.57	2	3.46	0.76	0.52	0.33	0.57	23	39.8	1.0	0.42	0		0			

Table 3.7. Mean number of barnacle adults and paired t-test results for tile pairs in 1992. Tile pairs were separated into 3 treatments. Three pairs of tarred and clean tiles were caged and 3 pairs were uncaged. Three tile pairs consisted of one clean and one painted black tile. N = 3 for each treatment. Sites ending with "C" are control sites; "X" denotes oiled sites.

Barnacle Adults		Caged Tiles						Uncaged Tiles						Painted Tiles					
Date	Site	Clean	Std	Oiled	Std	t-val	p-val	Clean	Std	Oiled	Std	t-val	p-val	Clean	Std	Paint	Std	t-val	p-val
6/03/92	1221C	0		0				0		0				0		0			
	1221X	0		0				0		0				0		0			
	1222C	0		0				1	0	0		0.00	1.0	0		0			
	1322X	3.33	4.16	0.66	1.15	0.92	0.45	0.33	0.57	0		1.0	0.42	1	1.73	0.66	1.15	1.0	0.42
	1723C	0		0				0		0				0		0			
	1723X	0.33	0.57	8.66	13.31	1.13	0.37	1	1.0	2	3.46	0.65	0.58	7.33	12.7	10	16.46	0.18	0.87
7/01/92	1221C	0.33	0.57	0		1.0	0.42	0		0				0		0			
	1221X	0		0				0		0				0		0			
	1222C	0		0.66	0.57	2.0	0.18	1.66	1.15	0		2.5	0.12	0		0			
	1322X	2	3.46	4	5.29	0.43	0.7	0		0				1	1.73	0.66	1.15	1.0	0.42
	1723C	0		0				0		0				0		0			
	1723X	0		0				0		0				6.66	11.54	0		1.0	0.42
7/31/92	1221C	2.33		1		2.0	0.18	0		0				0		0			
	1221X	0		1.66	2.88	1.0	0.42	0		0				0		0			
	1222C	0		1	1.0	1.73	0.22	5	1.0	4.33	4.93	0.2	0.86	0.66	1.15	2.33	3.21	0.71	0.54
	1322X	4	3.6	24.66	15.14	1.96	0.18	0		0				1.33	1.52	0.66	1.15	2.0	0.18
	1723C	0		0				0		0				0		0			
	1723X	0.33	0.57	0		1.0	0.42	0		0				0		0			
8/28/92	1221C	2.33	1.52	0		2.64	0.11	0		0				0		0			
	1221X	0		1	1.73	1.0	0.42	0		0				0		0			
	1222C	0		1.33	0.57	4.0	0.05	7	3.46	2	2.0	1.63	0.24	0.66	1.15	2	2.64	0.65	0.57
	1322X	3.66	3.78	21.66	12.42	2.0	0.17	0		0				1	1.73	0.66	1.15	1.0	0.42
	1723C	0		0				0		0				0		0			
	1723X	0		0.33	0.57	1.0	0.42	0.33	0.57	0		1.0	0.42	0		0			

Table 3.8. Mean number of *Chthamalus dalli* and paired t-test results for tile pairs in 1992. Tile pairs were separated into 3 treatments. Three pairs of tarred and clean tiles were caged and 3 pairs were uncaged. Three tile pairs consisted of one clean and one painted black tile. N = 3 for each treatment. Sites ending with "C" are control sites; "X" denotes oiled sites. Standard deviations are in parentheses.

<i>Chthamalus dalli</i>		Caged Tiles				Uncaged Tiles				Painted Tiles			
Date	Site	Clean	Oiled	t-val	p-val	Clean	Oiled	t-val	p-val	Clean	Paint	t-val	p-val
6/03/92	1221C	0	0			0	0			0	0		
	1221X	0	0			0	0			0	1.00 (1.73)	1.00	0.42
	1222C	0	0			0	0			0	0		
	1322X	0.66 (1.15)	7.66 (6.50)	1.84	0.20	11.66 (9.07)	0.66 (1.15)	2.40	0.13	48.33 (59.40)	104.33 (148.50)	1.07	0.39
	1723C	0	0			0	0			0	0		
	1723X	1.33 (1.52)	8.00 (13.80)	0.81	0.50	47.00 (81.40)	34.30 (51.05)	0.70	0.55	0	0		
7/01/92	1221C	7.00 (11.26)	0	1.07	0.39	0	0			0	0		
	1221X	0	0			0	0			0	0.33 (0.57)	1.00	0.42
	1222C	0	0			7.00 (2.64)	6.33 (8.38)	0.10	0.92	0.66 (1.15)	2.33 (4.04)	1.00	0.42
	1322X	1.00 (1.00)	25.33 (17.61)	2.53	0.12	11.00 (8.71)	0.66 (1.15)	2.36	0.14	31.33 (31.56)	46.33 (51.03)	1.25	0.33
	1723C	0	0			0	0			0	0		
	1723X	2.33 (1.15)	12.33 (11.60)	1.64	0.24	39.00 (63.23)	33.00 (43.31)	0.51	0.33	0	4.66 (8.08)	1.00	0.42
7/31/92	1221C	0	0			0	0			0	0		
	1221X	0	0			0	0			0	0		
	1222C	0	0			0	0			0	0		
	1322X	0	2.66 (1.52)	3.02	0.09	13.00 (11.31)	1.00 (1.41)	1.71	0.33	50.66 (65.77)	77.66 (111.63)	0.99	0.42
	1723C	0	0			0	0			0	0		
	1723X	1.66 (2.08)	20.33 (21.20)	1.68	0.23	35.66 (57.40)	28.66 (36.60)	0.58	0.61	6.66 (11.54)	4.66 (8.08)	0.20	0.85
8/28/92	1221C	0	0			0	0			0	0		
	1221X	0	0			0	0			0	0		
	1222C	0	0			0	0			0	0		
	1322X	0.33 (0.57)	4.00 (1.73)	4.16	0.05	15.66 (8.08)	0.66 (1.15)	3.20	0.08	45.33 (57.07)	75.33 (106.00)	1.05	0.40
	1723C	0	0			0	0			0	0		
	1723X	1.66 (1.15)	14.33 (13.01)	1.82	0.21	32.66 (52.25)	21.00 (23.30)	0.70	0.55	5.66 (9.81)	5.33 (9.23)	0.03	0.97

Table 3.9. Mean Number of *Fucus* germlings and paired t-test results for tile pairs in 1991. Tile pairs were separated into 3 treatments. Three pairs of tarred and clean tiles were caged and 3 pairs were uncaged. Three tile pairs consisted of one clean and one painted black tile. N = 3 for each treatment. Sites ending with "C" are control sites; "X" denotes oiled sites. Standard deviations are in parentheses.

# <i>Fucus</i> germlings		Caged Tiles				Uncaged Tiles				Painted Tiles			
Date	Site	Clean	Oiled	t-val	p-val	Clean	Oiled	t-val	p-val	Clean	Paint	t-val	p-val
6/23/91	1221C	0	0			0	0			0	0		
	1221X	0	0			0	0			0	0		
	1222C	0	0			0	0			0	0		
	1322X	0	0			0	0			0	0		
	1723C	0	0			0	0			0	0		
	1723X	0	0			0	0			0	0		
7/03/91	1221C	0	0			0	0			0	0.33 (0.57)	1.00	0.42
	1221X	0	0			0	0			0	0		
	1222C	0	0			0	0			0	0		
	1322X	0	0			0	0			0	0		
	1723C	0	0			0	0			0	0		
	1723X	0	0			0	0			0	0		
7/15/91	1221C	0	0			0	0			0	0		
	1221X	0	0			0	0			0	0		
	1222C	0	0			0	0			0	0		
	1322X	0	0			0	0			0	0		
	1723C	0	0			0	0			0	0		
	1723X	0	0			0	0			0	0		
7/26/91	1221C	0	0			0	0			0	0		
	1221X	0	0			0	0			0	0		
	1222C	0.66	0	1.00	0.21	0	0.33 (0.57)	1.00	0.42	0	0.16 (0.48)	1.00	0.36
	1322X	0	0			0	0			0	0		
	1723C	0	0			0	0			0	0		
	1723X	0	0			0	0			0	0		

Table 3.9. (Continued)

# <i>Fucus</i> germlings		Caged Tiles				Uncaged Tiles				Painted Tiles			
Date	Site	Clean	Oiled	t-val	p-val	Clean	Oiled	t-val	p-val	Clean	Paint	t-val	p-val
8/06/91	1221C	0	0			0	0			0	0		
	1221X	5.33 (6.80)	0	1.35	0.30	0	0			0	0		
	1222C	0	0			0	0			0	0		
	1322X	0	0			0	0			0	0		
	1723C	0	0			0.33 (0.57)	0	1.00	0.42	0	0		
	1723X	0	0			0.66 (1.15)	0	1.00	0.42	0	0		
8/23/91	1221C	2.00 (2.00)	0	1.73	0.22	0	0			0	0		
	1221X	31.33 (24.19)	0	2.24	0.15	0	0			0	0		
	1222C	0	0			0	0			0	0		
	1322X	9.00 (6.00)	0	2.59	0.12	0	0			0	0		
	1723C	88.33 (38.50)	0	3.96	0.05	0.33 (0.57)	0	1.00	0.42	0	0		
	1723X	19.00 (20.07)	0	1.63	0.24	2.00 (2.00)	0	1.73	0.22	0.66 (1.15)	1	1.0	0.42

Table 3.10. Mean Number of *Fucus* germlings and paired t-test results for tile pairs in 1992. Tile pairs were separated into 3 treatments. Three pairs of tarred and clean tiles were caged and 3 pairs were uncaged. Three tile pairs consisted of one clean and one painted black tile. N = 3 for each treatment. Sites ending with "C" are control sites; "X" denotes oiled sites. Standard deviations are in parentheses.

# <i>Fucus</i> Germlings		Caged Tiles				Uncaged Tiles				Painted Tiles			
Date	Site	Clean	Oiled	t-val	p-val	Clean	Oiled	t-val	p-val	Clean	Paint	t-val	p-val
6/03/92	1221C	54.00 (65.05)	0.50 (0.57)	1.17	0.44	0	0			0.66 (1.15)	2.33 (4.04)	1.00	0.42
	1221X	14.60 (18.10)	0	1.39	0.29	0	0			0	0		
	1222C	0	0			0.66 (1.15)	0	1.00	0.42	0.66 (1.15)	1.00 (1.73)	1.00	0.42
	1322X	28.00 (26.05)	0.66 (1.15)	1.90	0.19	0.66 (1.15)	0	1.00	0.42	0	0		
	1723C	6.50 (2.51)	0	5.16	0.01	0	0			0	0		
	1723X	2.00 (1.41)	0.50 (0.70)	3.00	0.20	0.33 (0.57)	0	1.00	0.42	0.33 (0.57)	0.66 (0.57)	1.00	0.42
7/01/92	1221C	47.00 (40.44)	0.66 (1.15)	1.90	0.19	0	0			0	0		
	1221X	14.60 (11.93)	0	2.20	0.16	0	0			0	0		
	1222C	21.60 (13.80)	0.66 (1.15)	2.70	0.11	3.00 (3.00)	0	1.73	0.22	0	1.33 (2.30)	1.00	0.42
	1322X	39.00 (19.15)	0.33 (0.57)	3.60	0.07	0	0			0.33 (0.57)	0.33 (0.57)	1.00	1.00
	1723C	141.33 (192.05)	8.60 (5.77)	1.22	0.34	0	0			0	0		
	1723X	8.50 (2.12)	1.00 (1.41)	15.00	0.04	0.50 (0.70)	0	0.10	0.50	0.50 (0.70)	0.50 (0.70)	1.00	1.00
7/31/92	1221C	33.30 (26.57)	0	2.17	0.16	0	0			0	0		
	1221X	30.60 (42.82)	0	1.24	0.34	0	0			4.00 (6.92)	0	1.00	0.42
	1222C	20.60 (21.22)	0.66 (1.15)	1.57	0.25	0.33 (0.57)	0	1.00	0.42	0.33 (0.57)	1.33 (2.30)	1.00	0.42
	1322X	58.00 (51.09)	1.00 (1.73)	1.90	0.18	0	0			0	0		
	1723C	141.60 (214.13)	4.60 (5.68)	1.13	0.37	0	0			0	0		
	1723X	1.75 (2.87)	8.25 (16.50)	0.95	0.41	0.75 (1.50)	0	1.00	0.39	0	0		
8/28/92	1221C	14.33 (2.88)	1.30 (1.52)	7.50	0.02	0	0			0	0		
	1221X	23.00 (26.96)	49.66 (12.01)	1.24	0.34	0.33 (0.57)	0	1.00	0.42	4.00 (1.00)	1.33 (2.30)	1.43	0.28
	1222C	11.30 (9.01)	4.30 (7.50)	0.75	0.52	0.33 (1.73)	0	1.00	0.42	0.33 (0.57)	1.33 (2.30)	1.00	0.42
	1322X	50.00 (13.52)	12.00 (12.16)	2.70	0.11	1.33 (2.30)	0	1.00	0.42	1.00 (1.73)	0	1.00	0.42
	1723C	58.33 (85.92)	6.33 (4.04)	1.01	0.42	1.33 (0.57)	0	1.00	0.42	3.33 (5.77)	0	1.00	0.42
	1723X	2.00 (2.64)	0.33 (0.57)	1.38	0.30	0.66 (1.15)	0	1.00	0.42	0.33 (0.57)	0.33 (0.57)	0	1.00

Table 3.11. Mean percent algal cover and paired t-test results for tile pairs in 1992. Data were arcsin-transformed prior to analysis. Tile pairs were separated into 3 treatments. Three pairs of tarred and clean tiles were caged and 3 were uncaged. Three tile pairs consisted of one clean and one painted black tile. N = 3 for each treatment. Sites ending with 'C' are control sites; 'X' denotes oiled sites. Standard deviations are in parentheses. The 1990 tile percent cover data are listed separately, and were sampled only on 6/03/92. The 1990 tiles are equivalent to the uncaged oiled and and clean tile pairs placed in 1991. The sites not listed under 1990 had lost or destroyed tile pairs.

% Algal Cover		Caged Tiles						Uncaged Tiles						Painted Tiles					
Date	Site	Clean		Oiled		t-val	p-val	Clean		Oiled		t-val	p-val	Clean		Paint		t-val	p-val
6/03/92	1221C	0		0				31.00 (54.00)	0		1.00	0.42	0		0				
	1221X	0.30	(0.57)	0.60	(1.10)	1.00	0.42	29.00 (47.00)	2.00 (4.00)	1.09	0.38	0.30	(0.57)	0.30	(0.57)	0		1.00	
	1222C	0		0				21.00 (33.00)	1.00 (1.70)	1.04	0.40	0		0					
	1322X	0		0				27.00 (45.00)	0.60 (0.57)	1.03	0.40	0.30	(0.57)	0				1.00	0.42
	1723C	0		0				81.00 (23.00)	66.00 (36.00)	1.78	0.21	0		0					
	1723X	0.30	(0.57)	0		1.00	0.42	45.00 (32.00)	39.00 (51.00)	0.09	0.93	0.60	(0.57)	0				2.00	0.18
7/01/92	1221C	0.30	(0.57)	0		1.00	0.42	30.00 (29.00)	70.00 (44.00)	1.00	0.42	0.60	(0.57)	0				2.00	0.18
	1221X	0.60	(0.57)	0		2.00	0.18	39.00 (42.00)	71.00 (36.00)	0.72	0.54	0.60	(0.57)	0.30	(0.57)	1.00	0.42		
	1222C	1.00	(1.00)	0.30	(0.57)	1.73	0.22	99.00 (11.00)	28.00 (49.00)	2.58	0.12	1.16	(2.80)	3.60	(5.50)	1.30	0.32		
	1322X	32.00	(44.00)	14.00	(22.00)	1.50	0.27	92.00 (8.00)	16.00 (20.00)	4.62	0.04	4.30	(4.50)	2.00	(2.00)	1.60	0.24		
	1723C	1.00	(1.50)	0		1.50	0.26	78.00 (24.00)	18.00 (27.00)	3.92	0.06	1.60	(2.80)	1.60	(2.80)	0		1.00	
	1723X	2.50	(2.10)	1.00	(1.40)	0.60	0.65	47.00 (45.00)	0		1.44	0.38	0.50	(0.70)	0.50	(0.70)	0		1.00
7/31/92	1221C	49.00	(68.00)	0		1.01	0.49	70.00 (28.00)	0.50 (0.70)	3.42	1.18	0.50	(0.70)	0				1.00	0.50
	1221X	30.00	(51.00)	0		1.01	0.41	53.00 (8.40)	5.00 (8.40)	5.21	0.03	0		0					
	1222C	0		0				23.00 (23.00)	4.00 (5.00)	1.26	0.33	0.30	(0.57)	0				1.00	0.42
	1322X	2.00		2.60	(1.30)	1.30	0.32	21.00 (15.00)	17.00 (28.00)	0.24	0.41	0.30	(0.57)	0				1.00	0.42
	1723C	0		0				65.00 (56.00)	47.00 (44.00)	1.12	0.86	0.30	(0.57)	0				1.00	0.42
	1723X	0.30	(0.57)	2.00	(2.60)	1.00	0.42	53.00 (45.00)	30.00 (38.00)	0.95	0.44	1.00	(1.00)	0.60	(1.10)	1.00	0.42		
8/28/92	1221C	0.30	(0.57)	0		1.00	0.42	63.00 (37.00)	40.00 (39.00)	2.58	0.12	3.60	(5.50)	1.60	(2.80)	0.48	0.67		
	1221X	0.60	(0.57)	0		2.00	0.18	52.00 (44.00)	33.00 (41.00)	0.89	0.46	0.60	(0.57)	0				2.00	0.18
	1222C	42.00	(37.00)	0		1.92	0.19	47.00 (49.00)	17.00 (24.00)	1.00	0.42	0		0					
	1322X	14.00	(18.00)	0.30	(0.57)	1.30	0.32	41.00 (50.00)	11.00 (10.00)	1.08	0.39	64.00	(55.00)	36.00	(32.00)	1.93	0.19		
	1723C	2.00	(2.60)	0		1.30	0.32	36.00 (40.00)	6.00 (5.70)	1.42	0.28	26.00	(46.00)	1.60	(2.80)	1.00	0.42		
	1723X	3.60	(2.30)	0.30	(0.57)	2.00	0.18	40.00 (45.00)	8.00 (7.00)	1.25	0.34	25.00	(42.00)	0.60	(1.10)	1.04	1.40		

Table 3.11. (Continued)

White clay tiles placed in 1990, Uncaged

Date	Site	% Algal Cover				t-val	p-val
		Clean	Std	Oiled	Std		
6/03/92	1221X	7.5	15.00	0.4	0.5	1.07	0.34
	1322X	77.0	19.00	7.5	8.3	5.11	0.01
	1723C	0.5	0.57	0.0		1.73	0.18
	1723X	72.5	17.00	0.5	0.7	5.71	0.11

Table 3.12. Grazer densities compared between control and oiled sites of a juvenile mussel recruitment study. Section A presents means, standard deviations (STD) and ANOVA results. Section B shows repeated measures ANOVA results. Site 1361X is part of a segment known to have been treated with an OMNI boom, although oiling was observed to be moderate when the experiment was established. Site 1362X is located in Bear Cove, a protected embayment on the east side of Herring Bay, which received only light oiling in 1989 and was not treated.

3.12A. Means, STD, and ANOVA results

Site	Date	Count	Mean	STD	F-Ratio	p-Value	
1361C=	1	6/01/91	12	38.25	3.47	28.97	0
1361X=	2		12	11.83	3.47		
	1	6/10	12	39.58	4.76	14.25	0.001
	2		12	14.16	4.76		
	1	6/20	12	25.33	3.83	7.15	0.0139
	2		12	10.83	3.83		
	1	7/01	12	36.92	7.75	1.23	0.2788
	2		12	24.75	7.75		
	1	8/13	12	44.50	4.15	38.71	0
	2		12	8.00	4.15		
1362C=	1	6/01/91	12	35.33	12.21	1.29	0.269
1362X=	2		12	15.75	12.21		
	1	6/10	12	45.17	9.26	4.14	0.054
	2		12	18.50	9.26		
	1	6/20	12	25.33	4.31	1.72	0.2032
	2		12	17.33	4.31		
	1	7/01	12	31.92	5.27	0.04	0.8509
	2		12	30.50	5.27		
	1	8/13	11	30.18	5.38	0.45	0.5082
	2		12	25.17	5.15		

3.12B. Repeated Measures
Analysis of Variance Report

Source	DF	Sum-Squares	Mean Square	F-Ratio	Prob>F	Error Term
ANOVA Table for Response Variables: Time 1 - Time 5, Sites 1361C and 1361X						
A (SITE)	1	15870	15870	19.80	0.0002	S(A)
S(A)	22	17631.95	801.4523			None
DATE	4	2065.917	516.4791	2.88	0.0273	ERROR
SITE*DATE	4	2336.251	584.0627	3.25	0.0155	ERROR
ERROR	88	15803.03	179.5799			
TOTAL (Adj)	119	53707.16				
ANOVA Table for Response Variables: Time 1 - Time 5, Sites 1362C and 1362X						
A (SITE)	1	5170.094	5170.094	2.35	0.1400	S(A)
S(A)	21	46140.95	2197.188			None
DATE	4	1706.695	426.6738	1.08	0.3716	ERROR
SITE*DATE	4	2590.227	647.5568	1.64	0.1720	ERROR
ERROR	84	33183.08	395.0366			
TOTAL (Adj)	114	88791.04				

Table 3.13. A. Means and standard errors (SE) of barnacle recruits and juvenile *Mytilus* that settled on 9 cm² epoxy tiles mounted on floating settlement stations. Two were in the eastern portion of Herring Bay, and three were located in the western portion. Each site had three separate floating stations with 12 tiles each. B. Means, SE, and t-test results for the mean weight difference of plaster-of-paris hemispheres placed on the floating stations on three separate dates. Each station had four hemispheres per sample date. Hemispheres were left on the plates for approximately 120h.

A. Eastern Herring Bay					Central & Western Herring Bay							
Site	Date	Barnacle Recruits	SE	Mytilus SE	Site	Date	Barnacle Recruits	SE	Mytilus SE			
5012	6/10/91	0	0	0	145	6/10/91	0	0	0			
	6/17/91	0	0	0		6/17/91	0	0	0			
	6/24/91	0	0	0		6/24/91	0.33	0.4	0.66	0.81		
	7/01/91	0	0	2.33		1.07	7/01/91	0	0	2	1	
	7/08/91	0	0	15		1.22	7/08/91	0	0	13	2.44	
	7/15/91	0	0	50.3		34.3	7/15/91	0.33	0.4	90.66	11.38	
	7/23/91	0	0	89		13.4	7/23/91	0.33	0.4	>100	-	
	7/29/91	0	0	>100		-	7/29/91	0	0	>100	-	
	8/05/91	0	0	>100		-	8/05/91	0	0	>100	-	
	8/12/91	0	0	>100		-	8/12/91	0	0	>100	-	
	8/19/91	0	0	>100		-	8/19/91	0	0	>100	-	
122	6/10/91	0.33	0.4	0	0	125	6/10/91	0	0	0	0	
	6/17/91	0.33	0.4	0	0		6/17/91	0	0	0	0	
	6/24/91	0	0	0	0		6/24/91	0.66	0.81	1	1	
	7/01/91	0	0	2.66	2.67		7/01/91	0.33	0.4	2.33	1.62	
	7/08/91	0	0	14.33	6.78		7/08/91	1	1.22	4.66	1.47	
	7/15/91	0	0	72.66	33.4		7/15/91	0	0	24.6	26.6	
	7/23/91	0.33	0.4	82.6	21.2		7/23/91	1	1	>100	-	
	7/29/91	0	0	66.6	40.8		7/29/91	1.33	0.4	75.6	29.8	
	8/05/91	0	0	>100	-		8/05/91	0	0	73.3	32.6	
	8/12/91	0.33	0.4	90.66	11.7		8/12/91	1	1.22	>100	-	
	8/19/91	0	0	>100	-		8/19/91					
133	6/10/91	0	0	0	0	133	6/10/91	0	0	0	0	
	6/17/91	0	0	0	0		6/17/91	0	0	0	0	
	6/24/91	0	0	0	0		6/24/91	0	0	0	0	
	7/01/91	0	0		3.66		1.47	7/01/91	0	0	3.66	1.47
	7/08/91	0	0		11.33		2.15	7/08/91	0	0	11.33	2.15
	7/15/91	0	0		>100		-	7/15/91	0	0	>100	-
	7/23/91	0.66	0.4		90.66		11.4	7/23/91	0.66	0.4	90.66	11.4
	7/29/91	0.33	0.4		>100		-	7/29/91	0.33	0.4	>100	-
	8/05/91	0	0		>100		-	8/05/91	0	0	>100	-
	8/12/91	0	0		>100		-	8/12/91	0	0	>100	-
	8/19/91	0.33	0.4		47		32.8	8/19/91	0.33	0.4	47	32.8

B. Plaster-of-Paris Dissolution Hemispheres						
Date	Control N=24		Oiled N=36		t-val	p-val
	Mean Weight Difference	SE	Mean Weight Difference	SE		
5/19/91	27.3	1.23	26.9	1.28	0.21	0.82
6/17/91	41.9	0.81	43.5	0.72	1.49	0.14
8/03/91	41.4	1.11	34.8	0.9	4.55	0.00

Table 3.14. Means, standard errors (SE) and ANOVA test results of percent reduction of algal cover and limpet density from limpet fencing and caging studies conducted in 1991. The enclosures had treatments of algae retained "A" or removed. Additional treatments included limpet densities represented by 'X' for the mean density of limpets per 625 cm² (7 for the upper contour, 12 for the lower contour). Treatments were doubled (2X) and halved (X/2), as well as treatments with no limpets placed ("A0, "0").

Treatment	Percent Reduction in Algal Cover						Percent Reduction in Limpet Density					
	Control	SE	Oiled	SE	F-Ratio	p	Control	SE	Oiled	SE	F-Ratio	p
Fences												
Upper Contour (n=4)												
0	0	0	0	-	-	-	0	0	0	0	-	-
AO	0	0	+3.9	2.4	1.52	0.26	0	0	0	0	-	-
X/2	0	0	0	0	-	-	100	0	87.5	14	1.00	0.35
AX/2	36	12	+100	82	1.91	0.21	50	7	83	19	3.43	0.11
X	0	0	0	0	-	-	80	12	46	30	1.37	0.28
AX	0.7	0.6	+18	58			46	16	91	5	8.34	0.02
2X	0	0	0	0	-	-	78	12	82	12	0.05	0.82
A2X	28	10	48	39	0.3	0.6	79	13	92	4	0.97	0.36
Lower Contour (n=4)												
0	0	0	0	0	-	-	0	0	0	0	-	-
AO	+2.9	23	0	0	0.32	0.59	0	0	0	0	-	-
X/2	0	0	0	0	-	-	93	7	91	9	0.04	0.84
AX/2	20	14	24	16	0.03	0.86	81	21	91	9	0.26	0.62
X	0	0	0	0	-	-	68	4	100	0	72.99	0.0001
AX	20	11	18	14	0.01	0.92	88	12	85	13	0.04	0.85
2X	0	0	0	0	-	-	86	11	86	8	0.000	0.96
A2X	33	14	39	21	0.07	0.79	83	9	86	9	0.06	0.81
Cages												
Lower Contour only (n=3)												
0	0	0	0	0	-	-	0	0	0	0	-	-
A0	41	14	9	7	5.96	0.07	0	0	0	0	-	-
X/2	+47	57	33	41	1.94	0.20	22	6	16	3	1.00	0.37
AX/2	15	9	73	16	13.94	0.02	21	6	11	8	0.8	0.42
X	+11	14	33	40	1.63	0.27	22	2	33	9	0.73	0.44
AX	31	23	55	23	0.53	0.50	22	2	22	13	0.00	1.00
2X	+16	18	6	7	0.73	0.43	38	10	28	6	0.96	0.38
A2X	15	9	58	26	3.5	0.13	25	12	11	3	1.64	0.26

+ = increase in % cover

Table 3.15. Mean differences in limpet weight, length and width from the upper and lower contours of the limpet fencing study. Sample sizes of recovered limpets (N) and t-test p-values are also presented.

Treatment	Code	Upper Contour						Lower Contour					
		Control	N	Oiled	N	t-test p	Direction	Control	N	Oiled	N	t-test p	Direction
Weight Difference (in grams)													
2X	1	-0.34	5	0.09	6	0.1		0.03	10	0.00	6	0.04	C>0
A2X	2	0.01	8	0.06	4	0.1		0.01	8	0.01	4	0.84	
AX	3	0.02	14	0.16	3	0.01	C<0	0.01	5	0.04	5	0.3	
AX/2	4	0.34	2	0.2	6	0.02	C<0	0.07	2	0.05	2	0.72	
X	5	0.01	5	0.1	3	0.08		0.03	7	0.0	0	-	
X/2	6	0.0	0	0.02	2	-		0.01	1	0.03	2	-	
Length Difference (in mm)													
2X	1	0.4	5	1.3	6	0.35		0.3	10	-0.33	6	0.35	
A2X	2	-0.12	8	0.5	4	0.52		0.25	8	0.25	4	1.00	
AX	3	0.28	14	2.86	3	0.13		-0.3	5	1.4	5	0.05	C<0
AX/2	4	0.0	2	0.8	6	0.63		0.5	2	2.5	2	0.1	
X	5	0.4	5	1.83	3	0.19		1.0	7	0.0	0	-	
X/2	6	0.0	0	0.5	2	-		0.0	1	0.5	2	-	
Width Difference (in mm)													
2X	1	0.2	5	0.75	6	0.52		0.3	10	0.3	6	0.93	
A2X	2	0.5	8	1.0	4	0.58		0.12	8	0.25	4	0.67	
AX	3	0.36	14	2.3	3	0.08		-0.3	5	1.4	5	0.05	C<0
AX/2	4	0.5	2	1.5	6	0.18		-0.5	2	1.5	2	0.1	
X	5	0.0	5	1.5	3	0.26		1.0	7	0.0	0	-	
X/2	6	0.0	0	1.5	2	-		1.0	1	1.0	2	-	

Table 3.16. Mean differences in limpet weight, length and width from the limpet caging study. Sample sizes of recovered limpets (N) and t-test p-values are also presented.

Treatment	Code	Control	N	Oiled	N	t-test	Direction
Weight Difference (in grams)							
2X	1	-0.02	44	-0.02	49	0.76	
A2X	2	0.01	54	0.02	64	0.24	
AX	3	0.05	28	0.002	28	0.000	C>0
AX/2	4	0.002	14	0.4	15	0.3	
X	5	0.02	27	0.01	24	0.025	C>0
X/2	6	0.007	14	0.00	16	0.71	
Length Difference (in mm)							
2X	1	0.04	44	0.06	49	0.22	
A2X	2	0.02	54	0.39	64	0.0001	C<0
AX	3	0.25	28	0.32	28	0.71	
AX/2	4	0.14	14	1.06	15	0.006	C<0
X	5	0.18	27	0.25	24	0.65	
X/2	6	0.07	14	0.37	16	0.34	
Width Difference (in mm)							
2X	1	-0.02	44	0.13	49	0.8	
A2X	2	0.02	54	0.20	64	0.04	C<0
AX	3	0.17	28	0.28	28	0.48	
AX/2	4	0.07	14	0.53	15	0.05	C<0
X	5	0.44	27	0.04	24	0.02	C>0
X/2	6	0.0	14	0.06	16	0.73	

Table 3.17. Mean dry weights and standard errors (SE) of *Fucus* and filamentous algae taken from within fences and cages at the beginning and end of the experiments. ANOVA F-ratios and p-values are also presented. Both studies are pooled together for the "Beginning" and "End" results. The "Algae" and "No Algae" dry weights presented below are only from the caging experiment.

	<i>Fucus</i> Dry Weight (in grams)					Filamentous Algal Dry Weight (in grams)				
	Mean	SE	N	F-Ratio	p	Mean	SE	N	F-Ratio	p
Beginning of Experiment										
All Enclosures Combined										
Control	14.1	3.2	44	15.77	0.001	4.54	0.88	44	1.15	0.28
Oiled	1.2	0.39	44			6.0	1.04	44		
End of Experiment										
All Enclosures Combined										
Control	8.53	1.9	64	15.23	0.0002	3.13	0.76	64	0.56	0.45
Oiled	0.86	0.27	63			2.32	0.77	63		
"Algae" Treatments - Algae Retained in Cages Only										
Control	20.7	7.07	12	7.01	0.01	8.47	3.46	12	1.23	0.27
Oiled	1.79	0.86	12			5.0	1.67	12		
"No Algae" Treatments - Initially Cleared from Cages Only										
Control	0.000	-	12	1.00	0.32	1.91	1.01	12	3.47	0.07
Oiled	0.004	0.0041	12			0.009	0.009	12		

Table 3.18. The number of tagged limpets recovered from each site and treatment where *Fucus* canopy was removed and retained. Results from a Two-Sample Sign test are also presented. Location refers to the east or west side of Herring Bay.

Site	Location	Status	# Retrieved	Cleared Plot	Uncleared
133	West	Oiled	15	7	8
145	West	Oiled	4	2	2
5012	East	Oiled	3	1	2
5005	East	Control	2	1	1
5009	East	Control	2	2	-
5011	East	Control	2	2	-

Two-Sample Sign Test: C<N=2 p=0.68
 C=N=0
 C>N=2

Table 3.19. The mean number of dead limpets (out of 7) collected from oiled and non-oiled cages. Standard errors (SE) and t-test results are also shown.

Oiled	SE	Non-Oiled	SE	t-Value	p
Mean mortality of both limpet groups (n=8)					
2.75	0.88	1.625	0.375	1.17	0.28
Mortality of <i>Tectura persona</i> (n=4)					
2.50	1.19	1.25	0.62	0.92	0.38
Mortality of <i>Lottia pelta</i> (n=4)					
3.00	1.47	2.25	0.629	0.46	0.65

CHAPTER 4. GENERAL DISCUSSION

Physical Differences Among Sites

Herring Bay experiences many extremes in physical variables. Temperatures on intertidal substrata can range from 0° to over 43°C and desiccation stress can be severe on sunny or windy days. Salinity ranges from 3.5 to 29 ppt. Frequent storms produce high winds and waves. During winter months, ice may form in protected embayments and coves and scour the shorelines. Given these factors, which potentially affect intertidal populations, observed differences between sites cannot be solely attributed to oil or shoreline treatment. It is possible, however, to quantify these physical factors at oiled and control sites in order to ascertain differences between sites, and if differences exist, then to estimate their effect on community structure and dynamics. For example, if ice scouring is more severe at control sites compared to oiled sites and removes *Fucus* from the intertidal, then any observed decreases in *Fucus* at oiled sites would be a conservative estimate of the actual decrease.

Community Organization

To integrate the observations and experiments described in this report, an interaction web has been constructed (sensu Menge and Sutherland 1986), graphically showing the organization of the intertidal community of Herring Bay (Fig. 4.1). The figure shows all of the major organisms, or groups of organisms, (hereafter referred to as taxa) found in the rocky intertidal habitat in Herring Bay and interactions which occur between those taxa. Some higher trophic level taxa are also listed in the web based on studies on those higher trophic levels (Patten 1993, Sharp and Cody 1993). Each arrow indicates that the taxa from which the arrow originates has a negative effect on the taxa at the end of the arrow. In some cases, taxa may have a positive effect on others and these are indicated with a plus sign next to the arrow. The thickness of the arrow indicates the relative strength of the interaction. Stronger interactions exert more influence over the population structure of the target taxa than weaker interactions. In addition to biological taxa, physical "taxa" have been included because they may also influence organisms or interactions. In one case, a physical factor is affected by an organism; the presence of large *Fucus* plants reduces local desiccation stress. Most of the stronger interactions were elucidated through experiments and observations over the past three summers. Many of the weaker interactions were derived from unquantified observations. Field teams spent over 11 months in Herring Bay during the 1990, 1991 and 1992 sampling seasons, making extensive observations of study sites possible.

The web presented here (Fig. 4.1) represents the entire intertidal range over all study sites in Herring Bay. Not all of the species or entities co-occur at all sites or tide levels. For example, *Nucella* is patchily distributed throughout Herring Bay. Many of the entities exerting or receiving strong interactions are

found throughout the tidal range, although density peaks at certain tide levels are common. The major interactions of the web are a fair representation of the intertidal community in Herring Bay.

Large *Fucus* plants are the most abundant organism in the intertidal in Herring Bay in terms of biomass and play a central role in the interaction web. Large *Fucus* plants provide habitat and protection for gastropods from predation and desiccation, particularly *Lottia* spp. and *Littorina* spp. Large *Fucus* plants also seem able to outcompete other algae and *Fucus* germlings for space, light, and possibly nutrients. This is illustrated by higher abundances of ephemeral algae at sites where *Fucus* had lower percent covers due to removal by the EVOS and clean-up activities (Figs. 2.10-12). The mechanisms responsible for this competitive effect are presently unknown. Large *Fucus* plants also have the potential to remove algal germlings, including *Fucus*, and possibly barnacle recruits by the whiplash effect (Table 2.2). Finally, large *Fucus* plants can decrease the desiccation stress in local areas (Table 2.1). Ice can potentially remove large *Fucus* plants, creating bare patches.

In addition to whiplash from adult plants, *Fucus* germlings are vulnerable to predation by limpets and *L. sitkana* (personal observations) and to desiccation stress (Fig. 2.17). Compared to open rock surfaces, germlings located in cracks and crevices have greatly improved chances of survival in the presence of grazers and with respect to environmental stresses (Table 2.3).

Ephemeral algae are eaten by both littorines and limpets. In some cases, but not all, fewer ephemeral algae were observed in limpet fences and cages with herbivores present than in cages lacking herbivores. Reduced algal cover may enhance barnacle recruitment because ephemeral algae preempt space (Denley and Underwood 1979; Hawkins and Hartnoll 1983; van Tamelen 1987; Farrell 1988). Barnacle populations can be severely reduced by high densities of *Nucella* spp. (Menge 1978), but *Nucella* only occurs in isolated patches in Herring Bay (Fig. 3.6). Seastars, such as *Pycnopodia*, *Pisaster* and *Leptasterias*, are voracious predators and probably impact the populations of lower-intertidal limpets, mussels, and *Nucella*.

Some larger organisms rely heavily on the intertidal for food. Both river and sea otters have been observed feeding on mussels and seastars. Various birds frequently prey on intertidal invertebrates. Glaucous-winged gulls prey on seastars and American Black Oystercatcher chicks. Adult Black Oystercatchers feed primarily on mussels, clams, barnacles, and limpets and can alter the size structure of limpet populations on a local scale (Andres, unpublished data). Migratory shorebirds frequent Herring Bay, preying on small mussels and limpets (Andres, personal communication). Harlequin Ducks feed primarily on littorine snails, mussels, and limpets (Patten 1993). Crows and ravens have often been observed preying on *Nucella*.

Effects of the Oil Spill

There were three ways in which the interaction web could have been modified by the oil spill. First, the abundances of some entities in the web were reduced. The organisms damaged directly by the spill have been italicized and replaced with unfilled letters in the modified interaction web (Fig. 4.2). Second, entities which interacted strongly with those damaged by the spill may have changed abundances as an indirect effect of oil. Entities indirectly affected by the EVOS have been circled. Finally, the changes in abundances of some of the entities have caused changes in the strength or presence of interactions. Higher trophic level taxa which may have been indirectly affected by oil by foraging on contaminated intertidal invertebrates, but are not a focus of these studies, are represented by octagons.

A major consequence of the EVOS for the intertidal community was the loss of large *Fucus* plants in oiled areas (Figs. 2.1, 2.3, 2.5, 2.18). Without adult *Fucus*, limpets and littorines were left without a major structural component of their habitat. Desiccation stress was also more severe in oiled areas due to the lack of *Fucus* canopy (Table 2.3) and where tar was present, surface temperatures may have increased (Straughan 1976). Removal of the competitively dominant alga may have caused higher abundances of ephemeral algae (Fig. 2.10-12). No reductions in *Fucus* germlings were observed after the spill, but germlings suffered from higher desiccation stress due to the lack of adult *Fucus* canopy at oiled sites. Whiplash from adult plants was also reduced in oiled areas, but germlings were still confined to cracks and crevices in the substrate due to environmental conditions (Table 2.3).

Recruitment of barnacles, which were directly affected by the spill, has been high at oiled sites, probably due to circulation patterns (Table 3.5a, Figs. 3.8a and 3.8b). Limpet populations, although showing some recruitment, have yet to fully recover from the oil spill (Table 3.3). This delayed recovery of limpets may be related to the reduction of adult *Fucus* plants, resulting in increased predation and higher desiccation and heating stresses.

Recovery Processes

Fucus, the organism most affected by the spill, is also the most important in the community in terms of biomass and interactions. Therefore, it is logical that general recovery of the intertidal community hinges in great part on the recovery of *Fucus* populations, especially in the upper intertidal. The mechanisms of *Fucus* recovery have been discussed in Chapter 2. It was argued that successful *Fucus* recruitment required the presence of cracks and crevices in the substrate. The heterogeneities in the substrate protect newly settled *Fucus* from desiccation, herbivory, and whiplash from adult plants. Barnacle tests can also provide sufficient substrate heterogeneity to improve *Fucus* recruitment (Lubchenco 1984). Thus, as barnacles colonize areas denuded by the EVOS and grow to

sufficient size (0.5 - 1.5 cm), *Fucus* may follow. In this way, the heavy recruitment of barnacles observed at the oiled sites (Table 3.5.a, Figs. 3.8.a and 3.8.b) can possibly lead to enhanced recovery rates.

As *Fucus* becomes re-established and grows to larger sizes, the habitat should become more favorable for limpets and littorines. Ephemeral algae will be outcompeted and reduced to control levels. Desiccation stress will also be reduced as a *Fucus* canopy develops, enhancing recruitment of *Fucus* germlings. For reasons given above, *Fucus* can be used as an indicator to assess the current stage of recovery and to estimate times for damaged intertidal habitats to completely recover. This approach is justified, at least for the upper portion of the intertidal zone, because *Fucus* appears to play a central role in structuring this community. The invertebrates have recruited more rapidly at the lower intertidal levels where *Fucus* has recovered and is abundant.

Four summers after the EVOS, the intertidal communities of Herring Bay are recovering but have not fully recovered. Damage from oil and cleaning was minimal in the low intertidal in most cases, so recovery has been rapid in that area. In the mid-intertidal, damage was potentially severe, but due to relatively low desiccation stress, *Fucus* has almost completely recovered. Some invertebrates continue to show lower densities at several oiled sites in the mid- and low-intertidal, with only limited recovery in 1992 (Table 3.3, 3.4). Limpets showed decreasing population densities through 1991; they had lower densities at oiled sites in 1991 compared to 1990. The reasons for this are unclear, but one possible explanation is that the limpets survived oiling and clean-up operations and died due to other factors 1-2 years after the spill. Since *Fucus* canopy was removed in many of the oiled areas, limpets were exposed to higher desiccation stress and left open to visual predators such as oystercatchers, Harlequin Ducks, and other birds. Once the *Fucus* canopy is re-established, limpets may recover from their declines.

At the end of the 1992 season in the mid-intertidal, there were dense beds of young *Fucus* plants just starting to become reproductive. These plants were found in higher densities than the plants in control areas due to their smaller size. In the future, it is expected that the density of *Fucus* plants will fall to values similar to the control sites. We predict that it will take an additional one or two years for *Fucus* to fully recover in the mid-intertidal. In the upper intertidal, where desiccation stress is high, recovery of *Fucus* is proceeding slowly. As growth rates of plants of all sizes in the upper intertidal are greater at the oiled sites, the rate-limiting step seems to be settlement of *Fucus* eggs and recruitment of new germlings. Some recruitment has occurred but only in the deepest crevices in the rock surface. As the plants which have recruited into the high intertidal grow, they will be able to ameliorate desiccation stress, enhancing *Fucus* and invertebrate recruitment.

As the newly recruited *Fucus* plants in the upper intertidal zone grow and become reproductive, they will make environmental conditions more favorable for

further *Fucus* settlement and recruitment. Since *Fucus* recruitment in the high intertidal has been sparse and patchy (note the high variances in Figs. 2.4) full recovery is dependent upon the intraspecific enhancement of settlement and recruitment of new plants after the maturation of the initial recruits. Recovery may take up to another four or five years as this second set of recruiting plants grows and matures. This estimate assumes that recovery will be completed after the second recruiting class of plants colonizes the upper intertidal and grows to maturity. Additional recruiting classes may be necessary, increasing the time to full recovery. In addition, after *Fucus* has fully recovered, invertebrates must also colonize the damaged habitats, so monitoring of invertebrates is necessary to fully assess recovery.

Restoration of *Fucus* in this damaged habitat may be warranted and feasible on small scales. The recovery of *Fucus* may take many more years in the high intertidal zone, especially on shorelines with a southern aspect as these shores would be subjected to greater desiccation stress. The easiest method of active restoration would be to enhance the recovery process of *Fucus*. This would involve reducing desiccation stress and perhaps supplying the damaged habitat with *Fucus* embryos. Desiccation can be reduced by securing coarsely woven fabric over the substrate which would retain moisture and reduce solar radiation. *Fucus* embryos can be supplied by inducing fertile plants to release their eggs in the laboratory and then spreading these eggs over the area to be restored. We have also presented evidence that oil still adhering to the substrate can reduce algal recolonization. DeVogelaere and Foster (1993) have shown that in Herring Bay tar spots disappeared rapidly. Only about 10-20% of tar patches marked in fall 1990 remained after 11 months. Therefore, further cleaning of this habitat is unwarranted.

Applications to Other EVOS Impacted Areas

We have shown here that the damage to our sites in Herring Bay are similar to the EVOS impacts documented in the CHIA studies in Prince William Sound. For this reason, we feel that the community dynamics described here may apply over the entire Prince William Sound region. Due to greater exposure to wave forces, the other two areas sampled by the CHIA studies, however, seem to show different patterns of damage. These two areas, Cook Inlet/Kenai and Kodiak/Alaska Peninsula, are subjected to large waves generated in the Gulf of Alaska which have created intertidal communities which are more diverse and are more productive (Leigh *et al.* 1987). This exposure may result in community dynamics which are quite different from those occurring in the relatively wave-protected areas of Prince William Sound. Due to these possible differences in community organization resulting from higher wave exposure and the differences observed in community structure (Highsmith *et al.* 1993), we feel that the results obtained in Herring Bay may not be applicable to Cook Inlet/Kenai or Kodiak/Alaska Peninsula.

To Clean or Not to Clean

Due to the lack of adequate treatment records, it was not possible to experimentally assess the impact of various clean-up technologies on the intertidal community. However, it is thought that site 1732X, as well as several of the barnacle recruitment study sites, were not treated. Comparison with control site 1732C showed few differences in the densities of invertebrates and *Fucus* and the percent cover of *Fucus*, suggesting that the oil per se had little effect on the components of the intertidal community discussed here. Unfortunately, due to lack of observations, there are no data on the level of oiling at 1732X. On a smaller site immediately adjacent to 1732X, heavy tarring remained as late as September 1992. Further, a nearby site, 1311X, had relatively high hydrocarbon concentrations (Table 3.2). Sites which did receive clean-up treatments often showed reductions in *Fucus* and invertebrate populations compared to controls, suggesting that the severe clean-up technologies applied in Herring Bay may have been more harmful to the intertidal communities than leaving the oil in place. In contrast, we have presented evidence that tar and oil stain on porous surfaces inhibits the settlement or early survival of some ephemeral algae, *Fucus* and some invertebrates, but that natural removal of oil on rock surfaces is proceeding rapidly. In contrast, ongoing studies of mussel beds which were oiled and not treated in Herring Bay still have some of the highest hydrocarbon concentrations in mussel tissue and sediment in Prince William Sound (Rounds, personal communication). Based on the interaction web presented here, mussel beds are potentially important forage areas for vertebrates in Herring Bay.

Recommendations

For future oil spills, the best strategy may be to utilize low to moderate intensity treatment methods to remove the thickest mats of oil while still leaving as much of the intertidal community intact as possible. Cleaning may be appropriate in protected embayments where oil would be less likely to be washed away and recruitment may be limited or sporadic. These recommendations, however, are based on the community studied in Herring Bay. Oil spills in other regions may need to be treated differently. For example, if oil were spilled in a northern, wave protected area similar to Herring Bay, but where the substrate was composed of porous rock, such as sandstone, an intensive approach to cleaning may be best for the intertidal community. The porous nature of the rock would tend to trap oil and allow greater adhesion of oil onto the substrate, potentially leading to longer weathering times for the oil. In this case, more intensive cleaning may be warranted since lingering oil may impede the recovery of the intertidal community. In geographic areas where the intertidal community is substantially different from the community studied here, the results and recommendations of this study may not apply.

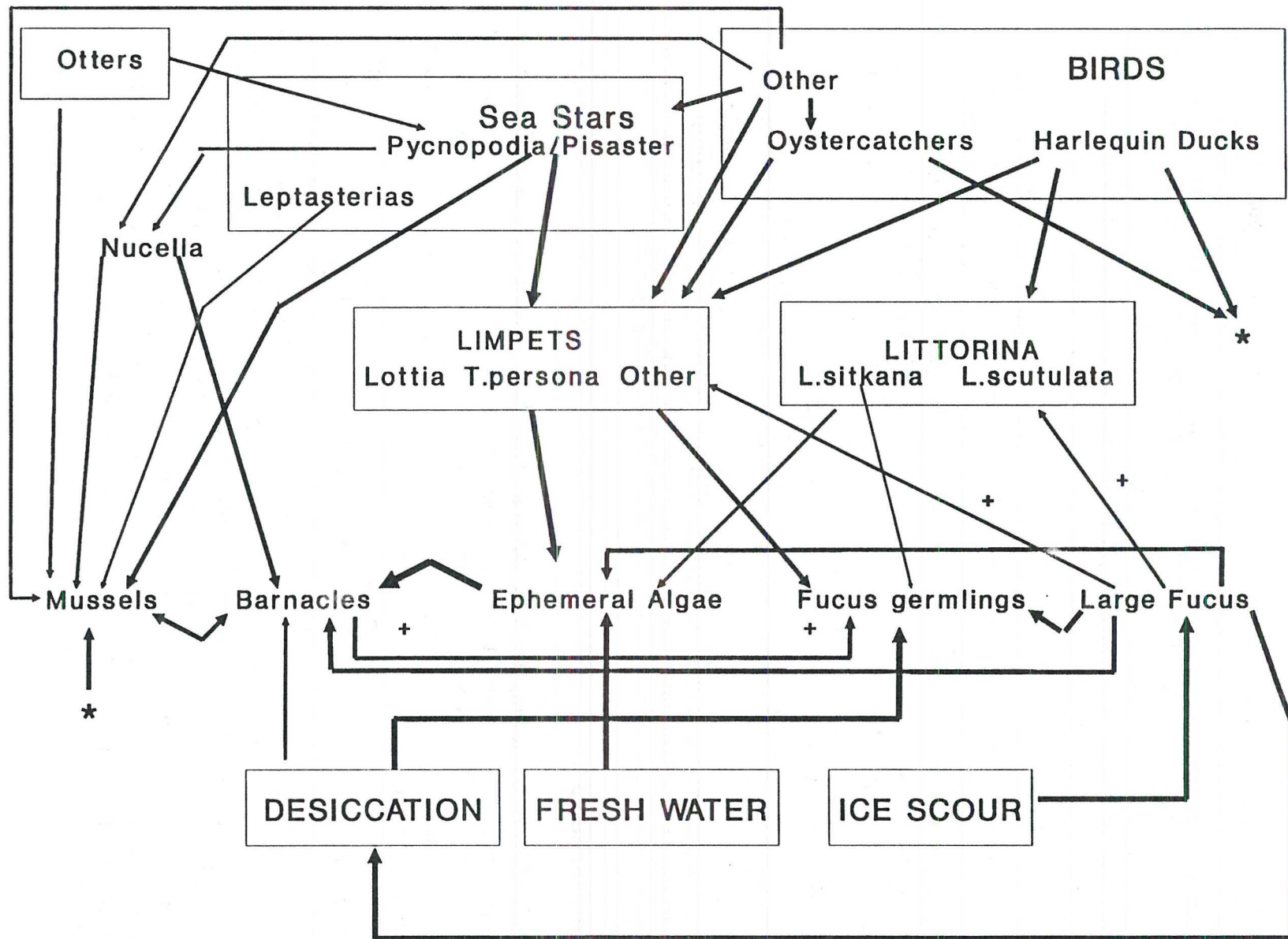

Figure 4.1. Organization of the intertidal community in Herring Bay. The arrows represent interactions among species or "taxa". The direction of the arrow represents a controlling or negative interaction. The thickness of each arrow indicates the strength of each interaction. In some cases, taxa have a positive "+" effect on others.

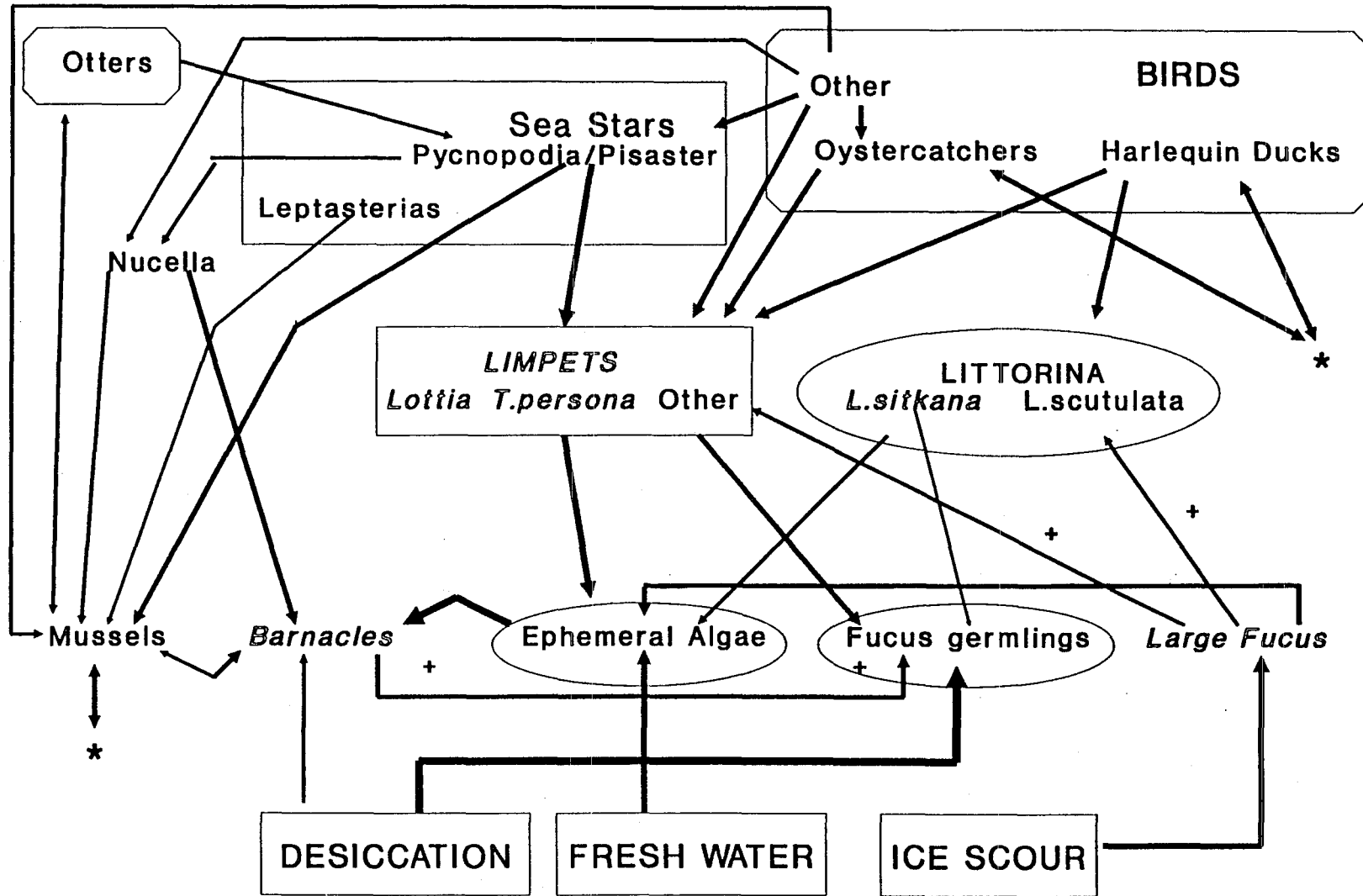

Figure 4.2. A modified organization of the Herring Bay intertidal community based on results from the algal and invertebrate studies. Those species directly affected by the oil or cleanup treatment are represented by italics and unfilled letters. Species indirectly affected are circled, and species which may have been affected but are the focus of other studies are encased in octagons. The interaction arrows changed by the EVOS are modified in strength or eliminated (Fig. 4.1).

REFERENCES

- Barnes, H. 1956 *Balanus balanoides* L. in the Firth of Clyde: The development and annual variation in the larval population and the causative factors. *J. Anim. Ecol.* 25:72-84.
- Barnes, R. D. 1987. *Invertebrate Zoology*. Fifth Edition. Saunders College Publishing. Orlando, FL. 893pp.
- Brawley, S. H. and L. E. Johnson. 1991. Survival of furoid embryos in the intertidal zone depends upon developmental stage and microhabitat. *J. Phycol.* 27:179-186.
- Brumley, W. C., A. J. Sheppard, and T. S. Rudolf. 1968. Mass spectrometry and identification of sterols in vegetable oils as butryl esters and relative quantitation by gas chromatography with flame ionization detection. *Journal of the Association of Official Analytical Chemists* 68:701-9.
- Chan, G. L. 1974. A study of the effects of the San Francisco oil spill on marine life. Part II: Recruitment. *In Conference on Prevention and Control of Oil Pollution.* pp. 457-461.
- Crothers, J. H. 1983. Field experiments on the effect of crude oil and dispersants on the common animals and plants of rocky sea shores. *Mar. Environ. Res.* 8:215-239.
- Dayton, P.K. 1971. Competition, disturbance, and community organization: The provision and subsequent utilization of space in a rocky intertidal community. *Ecol. Monogr.* 41:351-389.
- Denley, E. J., and A. J. Underwood. 1979. Experiments on factors influencing settlement, survival, and growth of two species of barnacles in New South Wales. *J. Exp. Mar. Biol. Ecol.* 36:269-293.
- DeVogelaere, A. P. and M. S. Foster. 1993. Damage, recovery, and restoration of intertidal *Fucus* following the *Exxon Valdez* oil spill. Final report to Environmental Protection Agency. 45pp.
- Duncan, P. B. 1991. Influence of the *Exxon Valdez* Oil Spill on intertidal algae: A test of the effect of residual oil on algal colonization. Report to the Alaska Department of Environmental Conservation. IPA Task 4. US EPA, Region 10, Seattle, Washington.
- Duncan, P. B., A. J. Hooten and R. C. Highsmith 1992. Influence of the *Exxon Valdez* oil spill on intertidal algae: tests of the effect of residual oil on algal colonization. *Exxon Valdez* Oil Spill Symposium abstracts, pp. 73-74.

- Ebert, T., D. Lees, and H. Cumberland. 1992. Growth and survival of the predatory snail *Nucella lamellosa* in areas exposed to the *Exxon Valdez* oil spill. *Exxon Valdez Oil Spill Symposium abstracts*, pp. 73-74.
- Farrell, T. M. 1988. Community stability: Effects of limpet removal and re-introduction in a rocky intertidal community. *Oecologia* 75:190-197.
- Feder, H. M., and B. Bryson-Schwafel. 1988. The intertidal zone. In D. G. Shaw and M. J. Hameedi (eds.), *Environmental Studies in Port Valdez, Alaska. Lecture notes on coastal and estuarine studies*, Vol. 24. Springer-Verlag, pp. 117-164.
- Gaines, S. D. and J. Lubchenco. 1982. A unified approach to marine plant-herbivore interactions. II. Biogeography. *Ann. Rev. Ecol. Syst.* 13:111-138.
- Hawkins, S. J., and R. G. Hartnoll. 1983. Grazing of intertidal algae by marine invertebrates. *Oceanogr. Mar. Biol. Annu. Rev.* 21:195-282.
- Highsmith, R. C., M. S. Stekoll, W. E. Barber, L. Deysher, L. McDonald, D. Strickland, and W. P. Erickson. 1992. Comprehensive assessment of coastal habitat. Draft preliminary status report to the *Exxon Valdez Oil Spill Trustees*, December 1992.
- Houghton, J. P., D. C. Lees, H. Teas, III, H. L. Cumberland, S. Landino and T. A. Ebert. 1991. Evaluation of the intertidal and shallow subtidal biota in Prince William Sound following the *Exxon Valdez* oil spill and subsequent shoreline treatment. Report No. HMRB 91-1 National Oceanographic and Atmospheric Administration.
- Jackson, J. B. C., J. D. Cubit, B. D. Keller, V. Batista, K. Burns, H. M. Caffey, R. L. Caldwell, S. D. Garrity, C. D. Getter, C. Gonzalez, H. M. Guzman, K. W. Kaufmann, A. H. Knap, S. C. Levings, M. J. Marshall, R. Steger, R. C. Thompson and E. Weil. 1989. Ecological effects of a major oil spill on Panamanian coastal marine communities. *Science* 243:37-44.
- Kendziorek, M., and M. S. Stekoll. 1984. Intraspecific competition and the management of the Bristol Bay herring-roe-on-kelp fishery. *Hydrobiologia* 116/117:333-337.
- Lees, D. C., W. B. Driskill, and J. P. Houghton. 1993. Short-term biological effects of shoreline treatment on intertidal biota exposed to the *Exxon Valdez* oil spill. *Exxon Valdez Oil Spill Symposium* 69-72.
- Leigh, E. G., R. T. Paine, J. F. Quinn, and T. H. Suchanek. 1987. Wave energy and intertidal productivity. *Proc. Natl. Acad. Sci.* 84:1314-1318.

- Lubchenco, J. 1978. Plant species diversity in a marine intertidal community: Importance of herbivore food preference and algal competitive abilities. *Am. Nat.* 112:23-39.
- Lubchenco, J. 1983. *Littorina* and *Fucus*: Effects of herbivores, substratum heterogeneity, and plant escapes during succession. *Ecology* 64:1116-1123.
- Manly, B. F. J. 1991. RT: A program for randomization testing. Ver. 1.01. West, Inc. Cheyenne, Wyoming. 16 pp.
- Mann, K. H., and R. B. Clark. 1978. Long-term effects of oil spills on marine intertidal communities. *J. Fish. Res. Bd. Can.* 35:791-795.
- McConnaughey, J. 1985. The growth and regeneration of the rockweed, *Fucus distichus*, in Bristol Bay. M.S. Thesis, University of Alaska Juneau. 106 pp.
- McCook, L. J., and A. R. O. Chapman. 1992. Vegetative regeneration of *Fucus* rockweed canopy as a mechanism of secondary succession on an exposed rocky shore. *Botanica Marina* 35:35-46.
- Menge, B. A. 1978. Predation intensity in a rocky intertidal community: Effect of an algal canopy, wave action and desiccation on predator feeding rates. *Oecologia* 34:17-35.
- Menge, B. A., and J. P. Sutherland. 1986. Community regulation: Variation in disturbance, competition, and predation in relation to environmental stress and recruitment. *Am. Nat.* 130:730-757.
- Nelson-Smith, A. 1977. Recovery of some British rocky seashores from oil spills and cleanup operations. In J. Cairns, Jr., K. L. Dikson, and E. E. Herricks (eds.), *Recovery and Restoration of Damaged Ecosystems*. Proc. Intl. Symposium on the Recovery of Damaged Ecosystems. Virginia Polytechnic Institute, Blackburg, Virginia, 23-25 March 1975. University Press of Virginia, pp. 190-207.
- Patten, S. M. 1993. Acute and sublethal effects of the *Exxon Valdez* oil spill on Harlequins and other seaducks. *Exxon Valdez Oil Spill Symposium* 151-154.
- Peterson, J. H. 1984. Larval Settlement behavior in competing species: *Mytilus californianus* Conrad and *M. edulis* L. *J. Exp. Mar. Biol. Ecol.* 82:147-159.
- Rosenthal, R. J., D. C. Lees, and D. J. Maiero. 1982. Description of Prince William Sound shoreline habitats associated with biological communities.

Unpublished report prepared for the Department of Commerce, NOAA,
Office of Pollution Assessment, Juneau, Alaska. 58 pp. plus appendices.

- Sanders, H. L. 1978. *Florida* oil spill impact on the Buzzards Bay benthic fauna: West Falmouth. *J. Fish. Res. Bd. Can.* 35:717-730.
- Sharp, B. E. and M. Cody. 1993. Black oystercatchers in Prince William Sound: oil spill effects on reproduction and behavior. *Exxon Valdez Oil Spill Symposium* 155-158.
- Sousa, W. P. 1979. Experimental investigations of disturbance and ecological succession in a rocky intertidal community. *Ecol. Monogr.* 49:227-254.
- Southward, A. J., and E. C. Southward. 1978. Recolonization at Cornwall after use of toxic dispersants to clean up the Torrey Canyon spill. *J. Fish. Res. Bd. Can.* 35:682-706.
- Straughan, D. 1976. Temperature effects of crude oil in the upper intertidal zone. US EPA report EPA-600/2-76-127. 53 pp.
- Suchanek, T. H. 1978. The ecology of *Mytilus edulis* L. in exposed rocky intertidal communities. *J. Exp. Mar. Biol. Ecol.* 31:105-120.
- van Tamelen, P. G. 1987. Early successional mechanisms in the rocky intertidal: The role of direct and indirect interactions. *J. Exp. Mar. Biol. Ecol.* 112:39-48.